



Stechdrehen

Grooving

2018/2019





Die neuen Kataloge von HORN – Maßstäbe für Ihre Produktivität

Unsere Werkzeuge bieten Ihnen von der Einzelteil- bis zur Serienfertigung, bei Standard- oder Sonderanwendungen, schnelle, wirtschaftliche und qualitativ hochwertige Lösungen.

Die Welt unserer Zerspanung mit Standardwerkzeugen haben wir jetzt in den neuen Katalogen

- Stechdrehen
- Supermini und Mini Innenbearbeitung
- Modulare Haltersysteme
- Hochharte Schneidstoffe
- Frässysteme
- Bohren und Reiben
- VHM-Fräswerkzeuge
- Boehlerit Drehen
- Boehlerit Fräsen

zusammengefasst. In jedem Katalog erleichtert Ihnen die Gliederung in typenbezogene Arbeitsverfahren das schnelle Auffinden der bestellgerecht beschriebenen Produkte. Bei der Wahl der individuellen Schnittparameter unterstützen Sie zahlreiche Tabellen mit praxis-erprobten Erfahrungswerten.

Lothar Horn
Geschäftsführer
Hartmetall-Werkzeugfabrik Paul Horn GmbH

New catalogues from HORN - benchmarks for productivity

Our tools provide you with fast, economical, high quality solutions, from single part to series production, for standard or special applications.

Our complete range of standard tools is summarised in the new catalogues

- Grooving
- Supermini & Mini Internal Machining
- Modular Holder Systems
- Ultra Hard Cutting Materials
- Milling Systems
- Drilling / Reaming
- Solid Carbide Mills
- Milling Catalogue Boehlerit
- Turning Catalogue Boehlerit

In each catalogue, the breakdown into the type of cutting process makes it easier for you to quickly find the products described. When choosing the individual cutting parameters, you will find numerous tables with proven empirical values.

Lothar Horn, CEO
Hartmetall-Werkzeugfabrik Paul Horn GmbH

Inhaltsverzeichnis / Index

A System 100 / 101

A

B System 117

B

C System 119 / 123 / 223

C

D System 209

D

E System 216

E

F System 217

F

G System 224

G

H System 229 / 259

H

I System 231

I

J System 262

J

K System 264

K

L System 274

L

M System 34T

M



Inhaltsverzeichnis / Index

N	System 312	N
O	System 315	O
P	System 316	P
Q	System 64T	Q
R	Werkzeuge für Langdrehmaschinen Tools for Swiss Type Machines	R
S	Axialeinstechen Face Grooving	S
T	Abstechen Parting Off	T
U	Technische Hinweise Technical Instructions	U
V	Nutstoßen Broaching	V
W	Zubehör / Anwendungsbeispiele Additional Equipment / Examples for Machining	W

System	15 25A	100	101	117	119	123	209	216	217	223	224	
Innenbearbeitung / Internal Grooving												
Bohrungs-Ø Bore Ø	15 - 50				≥ 16	≥ 16	≥ 16	≥ 20	≥ 20	≥ 18	≥ 28	
Stechbreite Width of groove	2 - 4				2 - 3	2 - 3	2 - 3	2 - 6	0,5 - 5,3	1,2 - 3	2 - 6	
Einstechen Grooving					•	•	•	•	•	•	•	
Längsdrehen Turning					•		•	•		•	•	
Gewinde Thread											•	
Profildrehen Profiling							•	•		•	•	
Axialeinstechen Facegrooving	•											
Außenbearbeitung / External Grooving												
Stechtiefe Depth of groove	≤ 25	≤ 55	≤ 13	≤ 10			≤ 25			≤ 4,7	≤ 11	≤ 32,5
Stechbreite Width of groove	2 - 4	2 - 16	1,6	10 - 45			2 - 3			0,5 - 5,3	1,2 - 3	2 - 6
Einstechen Grooving		•	•				•			•	•	•
Längsdrehen Turning		•									•	•
Abstechen Parting off		•	•								•	•
Gewinde Thread												•
Profildrehen Profiling				•					•			•
Axialeinstechen Facegrooving	•											•
Kapitel Chapter	S	A	A	B	C	C	D	E	F	C	G	

Sonderwerkzeuge sind auf Anfrage erhältlich
Special tools upon request

Abmessung in mm
Dimensions in mm

System	229 259	231	262	264	274	34T	312	315	316	64T
Innenbearbeitung / Internal Grooving										
Bohrungs-Ø Bore Ø	≥ 38	≥ 75					≥ 46	≥ 43		
Stechbreite Width of groove	2,5 - 10	2,5 - 10					0,5 - 6,3	0,5 - 8		
Einstechen Grooving	•	•					•	•		
Längsdrehen Turning	•							•		
Gewinde Thread	•	•						•		
Profildrehen Profiling	•							•		
Axialeinstechen Facegrooving										
Außenbearbeitung / External Grooving										
Stechtiefe Depth of groove	≤ 25	≤ 11	≤ 7,5	≤ 16	≤ 6	≤ 6,5	≤ 8	≤ 6	≤ 8	≤ 5,5
Stechbreite Width of groove	2,5 - 10	2,5 - 10	0,025 - 6	1,5 - 3	0,5 - 7	2 - 5	0,5 - 6,3	0,5 - 8	1,5 - 3	0,5 - 3,15
Einstechen Grooving	•	•	•	•	•	•	•	•	•	•
Längsdrehen Turning	•		•	•	•	•	•	•	•	•
Abstechen Parting off	•		•	•	•	•	•	•	•	•
Gewinde Thread	•	•		•	•			•		
Profildrehen Profiling	•							•		
Axialeinstechen Facegrooving	•	•					•	•		
Kapitel Chapter	H	I	J	K	L	M	N	O	P	Q

Sonderwerkzeuge sind auf Anfrage erhältlich
Special tools upon request

Abmessung in mm
Dimensions in mm

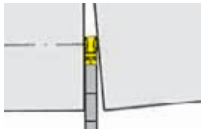

System 100
t_{max} = ≤ 60 mm

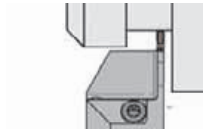

System 101
t_{max} = ≤ 13 mm

Klemmhalter
Toolholder
H100



Seite/Page
A3-A5

Klemmhalter
Toolholder
H101

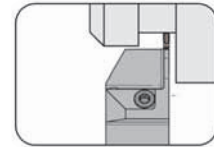

Seite/Page
A28

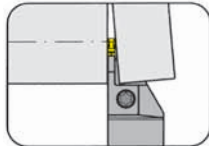

Seite/Page
A6-A12, A14, A24-A25

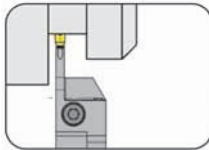

Seite/Page
A13, A15-A16

Kassette
Cassette
NK100

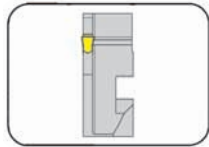

Seite/Page
A17

Schneidplatte
Insert
S100/S101

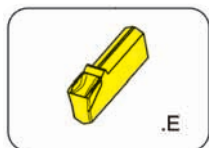

Seite/Page
A18

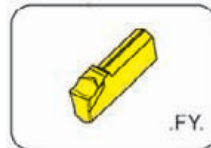

Seite/Page
A21



Seite/Page
A29

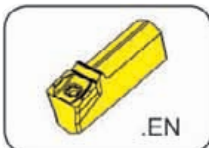

Seite/Page
A19, A26

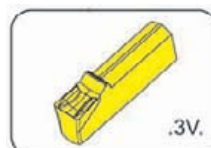

Seite/Page
A22, A27

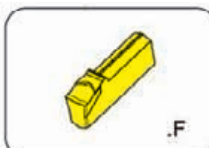

Seite/Page
A20



Seite/Page
A23

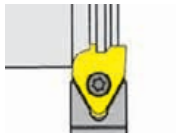

$t_{max} = \leq 10 \text{ mm}$
 $w = 10 - 45 \text{ mm}$

Klemmhalter
Toolholder
H117

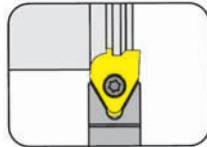

Seite/Page
B3-B4, B6, B8

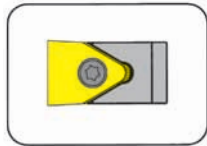

Seite/Page
B10

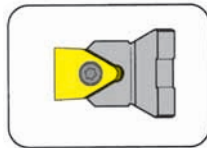

Seite/Page
B11

Schneidplatte
Insert
S117

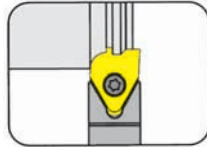

Seite/Page
B5, B7

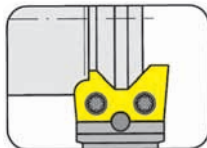

Seite/Page
B9

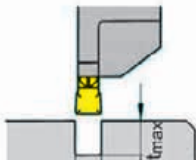

$w = 1,1 - 3 \text{ mm}$
 $t_{\text{max}} = 10 \text{ mm}$



$w = 1,1 - 3 \text{ mm}$
 $t_{\text{max}} = 6,3 \text{ mm}$
 $D \geq 16 \text{ mm}$

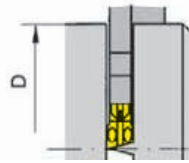

$w = 2 - 3 \text{ mm}$
 $D_{\text{max}} \leq 50 \text{ mm}$

Klemmhalter
Toolholder
H223/B119/B223

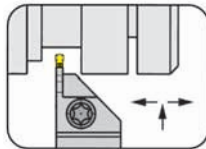

Seite/Page
C3

Kassette
Cassette
BK223

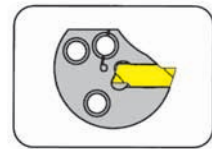

Seite/Page
C12

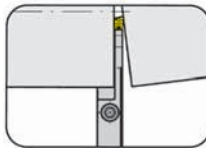

Seite/Page
C4

Schneidplatte
Insert
S119/S223/S123

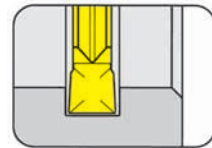

Seite/Page
C13, C16

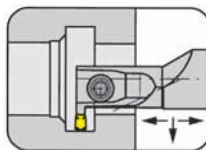

Seite/Page
C6-C8

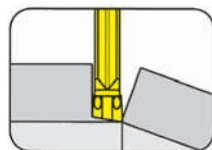

Seite/Page
C14-C15, C20-C21

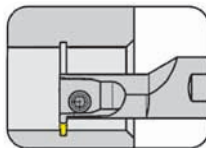

Seite/Page
C9

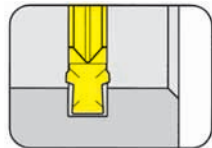

Seite/Page
C17

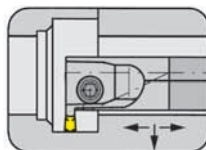

Seite/Page
C10

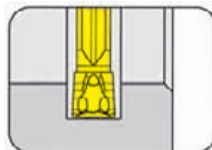

Seite/Page
C18

Kurzklemmhalter
Cartridge
E223

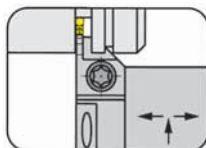

Seite/Page
C5

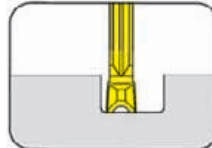

Seite/Page
C19

Grundhalter
Basic toolholder
B223

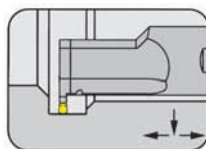

Seite/Page
C11

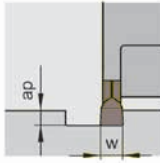

$w = 2 - 3 \text{ mm}$
 $a_{p \text{ max}} = 1 \text{ mm}$

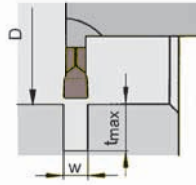

$w = 2 - 3 \text{ mm}$
 $t_{\text{max}} = 5 \text{ mm}$
 $D \geq 16 \text{ mm}$

Klemmhalter
 Toolholder
 B209

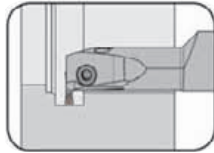

Seite/Page
 D3

Wendeschneidplatte
 Indexable insert
 S209



Seite/Page
 D4

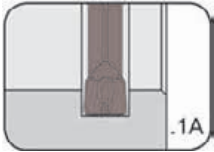

Seite/Page
 D5

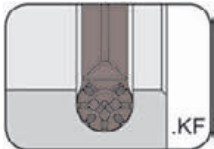

Seite/Page
 D6



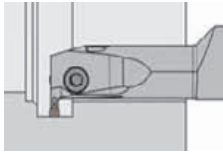

$D_{\min} = 20 \text{ mm}$
 $t_{\max} = 7,5 \text{ mm}$

Klemmhalter
Toolholder
B216

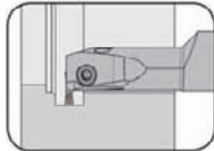

Seite/Page
E3

Wendeschneidplatte
Indexable insert
S216

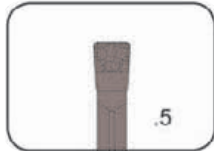

Seite/Page
E4



Seite/Page
E5

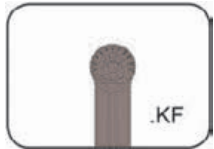

Seite/Page
E6

E

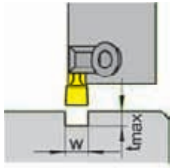

w = 0,5 - 5,3 mm
t_{max} = 4 mm

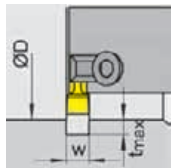

w = 0,5 - 5,3 mm
t_{max} = 4,7 mm
D ≥ 20 mm

Klemmhalter
Toolholder
240/248/230/233/
234/235/245

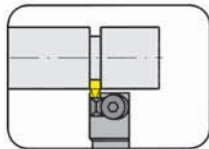

Seite/Page
F3-F5

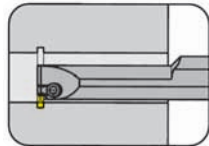

Seite/Page
F6

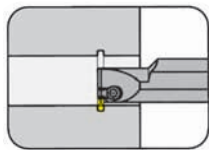

Seite/Page
F7

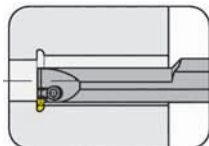

Seite/Page
F8

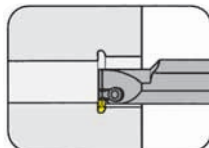

Seite/Page
F9

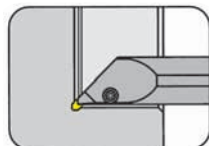

Seite/Page
F10

Wendeschneidplatte
Indexable insert
217

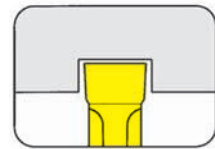

Seite/Page
F11

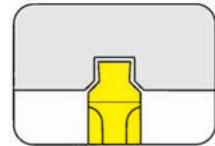

Seite/Page
F12

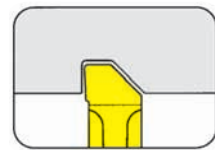

Seite/Page
F13



Seite/Page
F15

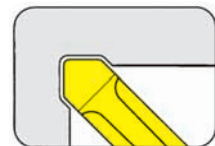

Seite/Page
F14

Kurzklemmhalter
Cartridge
232

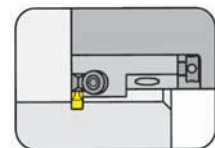

Seite/Page
F16

F

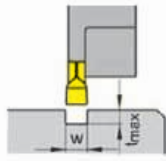

$w = 2 - 6 \text{ mm}$
 $t_{\text{max}} = 18 \text{ mm}$

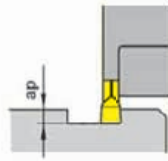

$w = 3 - 6 \text{ mm}$
 $a_{\text{pmax}} = 4 \text{ mm}$

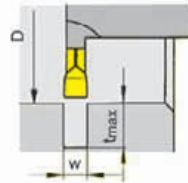

$w = 2 - 6 \text{ mm}$
 $t_{\text{max}} = 13 \text{ mm}$
 $D \geq 28 \text{ mm}$

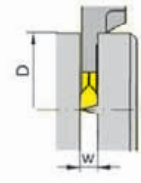

$w = 2 - 6 \text{ mm}$
 $D = 56 \text{ mm}$
 $t_{\text{max}} = 18 \text{ mm}$

Klemmhalter
Toolholder
H224/B224/224

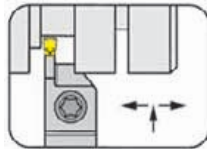

Seite/Page
G3-G10, G12-G17

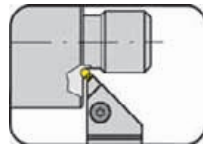

Seite/Page
G18



Seite/Page
G19, G22-G23

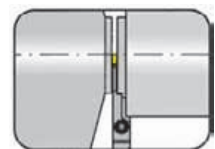

Seite/Page
G11, G20-G21

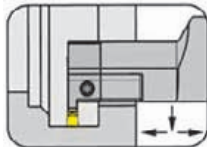

Seite/Page
G24-G28

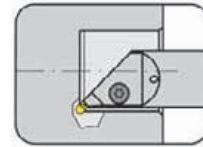

Seite/Page
G30-G31

Kassette
Cassette
BK224

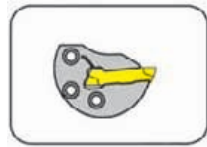

Seite/Page
G27

Schneidplatte
Inserts
S224/224/NS224

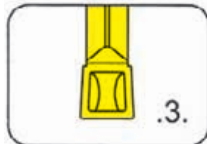

Seite/Page
G32-G33

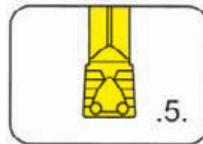

Seite/Page
G34-G35



Seite/Page
G36-G37

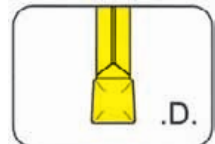

Seite/Page
G38-G39

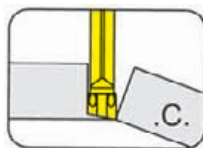

Seite/Page
G40-G41



Seite/Page
G42

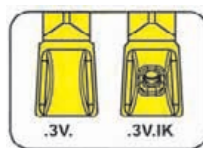

Seite/Page
G43, G55

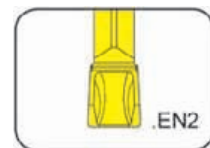

Seite/Page
G44

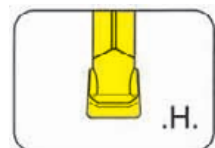

Seite/Page
G45

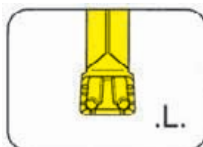

Seite/Page
G46-L47

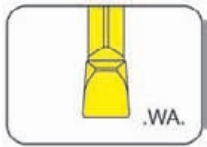

Seite/Page
G48

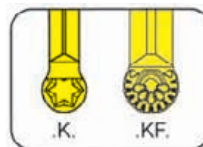

Seite/Page
G49-G50

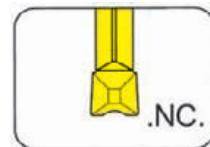

Seite/Page
G51

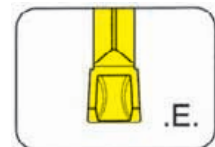

Seite/Page
G52

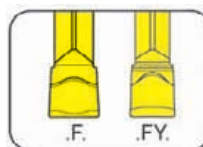

Seite/Page
G53-G54

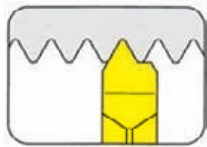

Seite/Page
G56-G57

G

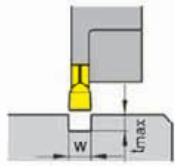

$w = 2,5 - 10 \text{ mm}$
 $t_{\text{max}} = 25 \text{ mm}$

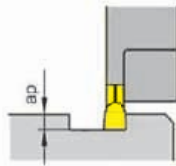

$w = 3 - 6 \text{ mm}$
 $a_p \leq 4 \text{ mm}$

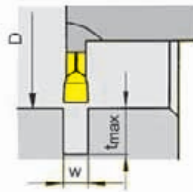

$w = 3 - 10 \text{ mm}$
 $t_{\text{max}} = 15 \text{ mm}$
 $D \geq 38 \text{ mm}$

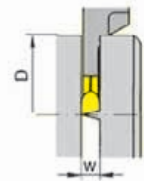

$w = 3 - 4 \text{ mm}$
 $t_{\text{max}} = 25 \text{ mm}$

Einstecken (außen) Grooving (external)

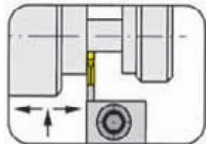

Seite/Page H2-H14, H16

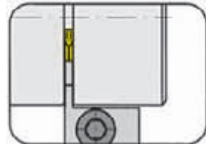

Seite/Page H15, H17

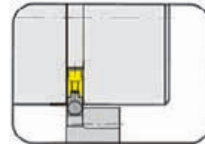

Seite/Page H18

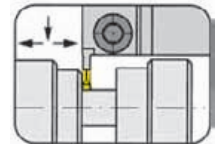

Seite/Page H19-H20



Seite/Page H21

Einstecken (innen) Grooving (internal)

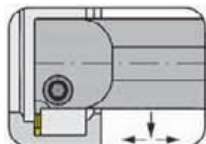

Seite/Page H22-H29



Seite/Page H30

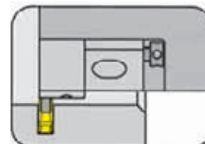

Seite/Page H31

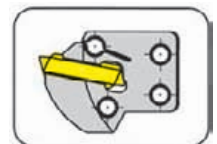

Seite/Page H32

Wendeschneidplatten Indexable inserts S229

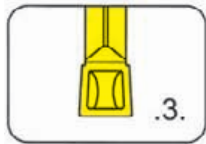

Seite/Page H34-H35

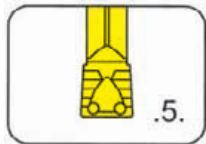

Seite/Page H36-H37



Seite/Page H38-H39

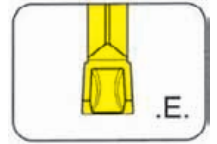

Seite/Page H40

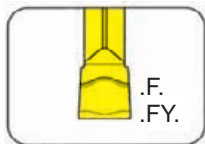

Seite/Page H43-H44

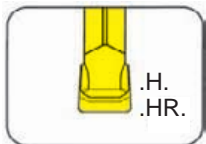

Seite/Page H43-H44

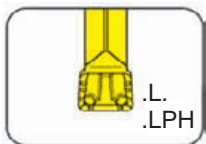

Seite/Page H45-H46

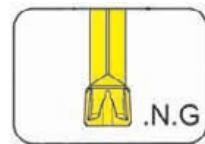

Seite/Page H47

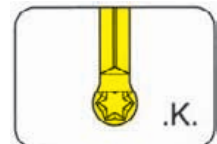

Seite/Page H48-H49

Wendeschneidplatten Indexable inserts 229

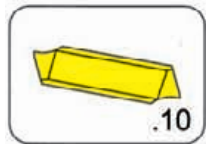

Seite/Page H50-H51

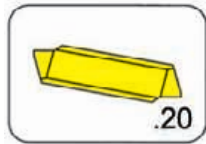

Seite/Page H52-H53

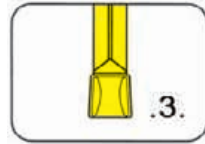

Seite/Page H54-H55

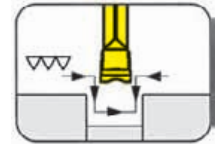

Seite/Page H56-H57

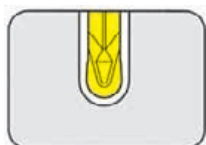

Seite/Page H58

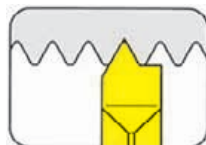

Seite/Page H59-H61

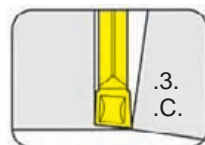

Seite/Page H62-H64

Klemmhalter Toolholder H259

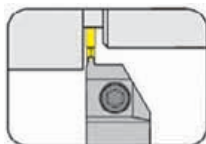

Seite/Page H65

Wendeschneidplatten Indexable inserts 259

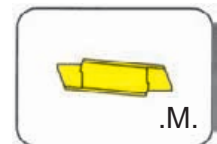

Seite/Page H66

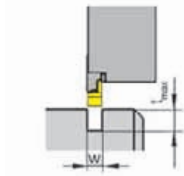

$w = 2,5 - 10 \text{ mm}$
 $t_{\text{max}} = 11 \text{ mm}$

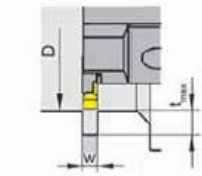

$w = 4 - 10 \text{ mm}$
 $t_{\text{max}} = 5 - 9 \text{ mm}$
 $D = 75 - 200 \text{ mm}$

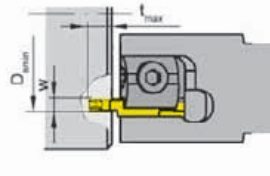

$w = 3 - 10 \text{ mm}$
 $t_{\text{max}} = 8 \text{ mm}$
 $D_{\text{a min}} \geq 30 \text{ mm}$



metr. Trapezgewinde
 metric trapezoidal thread

Klemmhalter
 Toolholder
 211/221/228

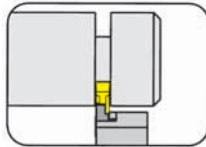

Seite/Page
 I3-I4

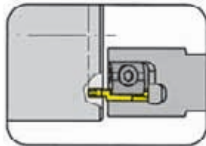

Seite/Page
 I11-I12

Kurzklemmhalter
 Cartridge
 208

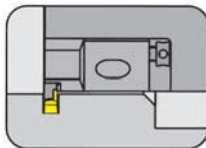

Seite/Page
 I5

Wendeschneidplatte
 Indexable insert
 231

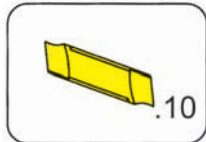

Seite/Page
 I7-I8

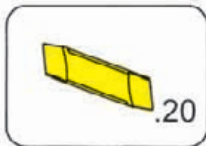

Seite/Page
 I9-I10

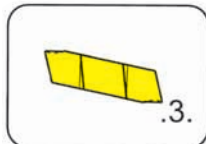

Seite/Page
 I13

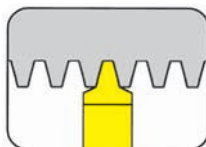

Seite/Page
 I14



Einstecken/Längsdrehen
Grooving and Side Turning

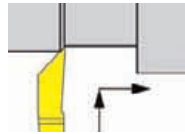

Kopierdrehen (Schlichten)
Copy Turning (Finishing)

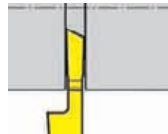

Abstechen
Parting off

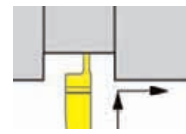

Einstecken/Rückwärtsdrehen
Grooving and Back Turning

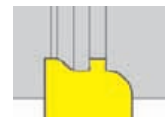

Halbzeug
Semi-finished Insert

Klemmhalter
Toolholder
262

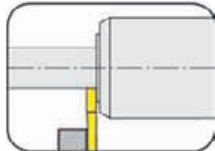

Seite/Page
J3

Wendeschneidplatte
Indexable insert
S262



Seite/Page
J4

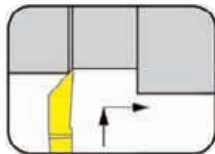

Seite/Page
J5

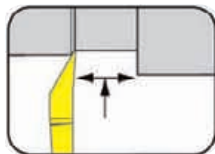

Seite/Page
J6



Seite/Page
J7

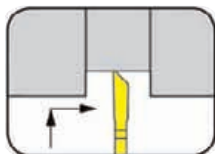

Seite/Page
J8-J9

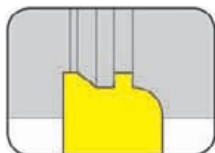

Seite/Page
J10



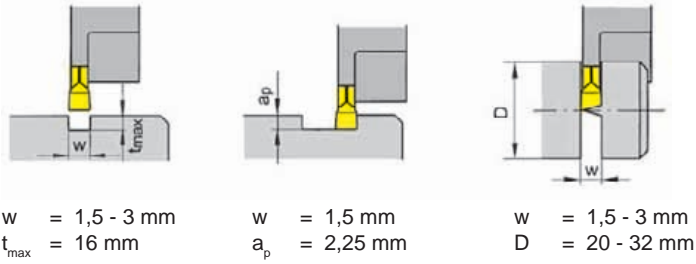

Klemmhalter
Toolholder
H264

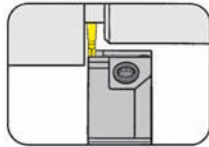

Seite/Page
K3-K6

Wendeschneidplatte
Indexable insert
264

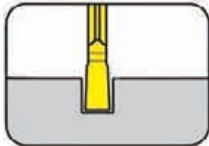

Seite/Page
K7, K9, K11



Seite/Page
K8, K10

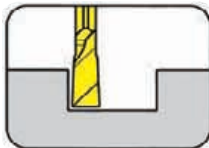

Seite/Page
K12-K13

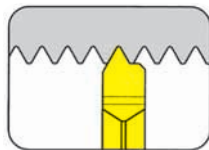

Seite/Page
K14

K

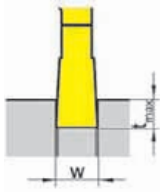

$w = 0,5 - 7,0 \text{ mm}$
 $t_{\text{max}} = 6,0 \text{ mm}$

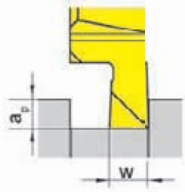

$w = 0,5 - 2,0 \text{ mm}$
 $a_p = 6,0 \text{ mm}$

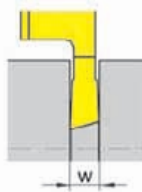

$w = 0,8 - 2,0 \text{ mm}$

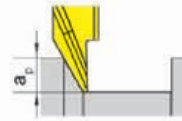

$a_p = 6,0 \text{ mm}$

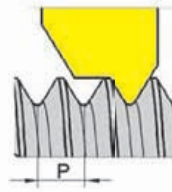

Teilprofil/Partial profile
 $P = 0,24 - 0,4 \text{ mm}$
Vollprofil/Full profile
 $P = 0,5 - 1,5 \text{ mm}$

Klemmhalter
Toolholder
H274/H274...E/
H274...SF/HC274

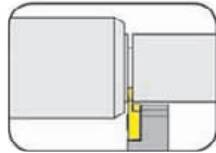

Seite/Page
L3, L6, L29, L46-L47



Seite/Page
L4-L5

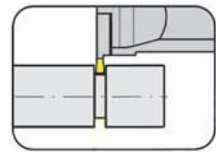

Seite/Page
L8

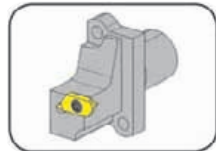

Seite/Page
L9

Wendeschneidplatte
Indexable insert
S274/S274...E/
S274...SF



Seite/Page
L13-L14, L30-L31

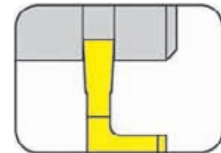

Seite/Page
L15-L17, L32-L34

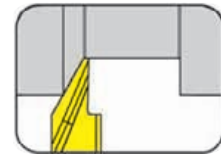

Seite/Page
L18, L35

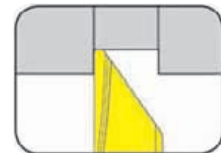

Seite/Page
L19, L36

Klemmhalter Graf
Toolholder Graf
974



Seite/Page
L7

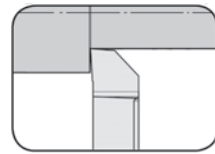

Seite/Page
L48



Seite/Page
L20-L25, L37-L42, L51-L52

Einbauhalter
Cartridge
KT274/KTC274

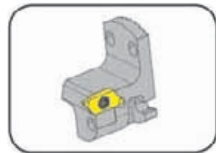

Seite/Page
L10-L11

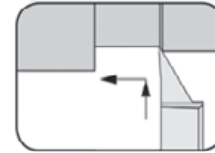

Seite/Page
L49-L50

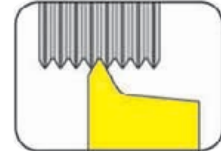

Seite/Page
L26, L43

Einbauhalter Graf
Cartridge Graf
64



Seite/Page
L12

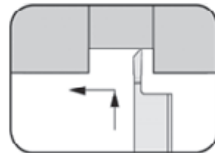

Seite/Page
L53-L54

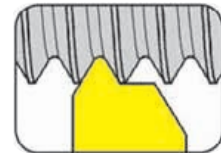

Seite/Page
L27-L28, L44-L45



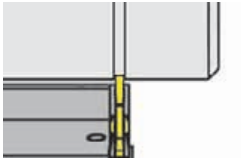

w = 2,0 - 5,0 mm
t_{max} = 6,50 mm

Klemmhalter
Toolholder
H34T

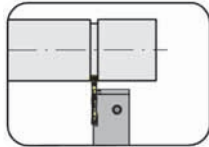

Seite/Page
M3

Wendeschneidplatte
Indexable insert
S34T

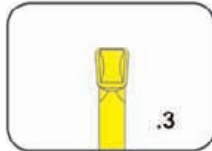

Seite/Page
M4

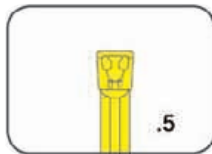

Seite/Page
M5

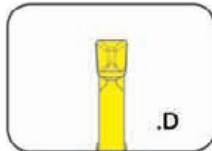

Seite/Page
M6

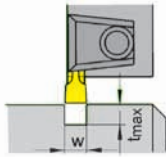

$w = 0,5 - 6,3 \text{ mm}$
 $t_{\text{max}} = 8,0 \text{ mm}$



$w = 0,5 - 6,3 \text{ mm}$
 $t_{\text{max}} = 5,5 \text{ mm}$
 $D \geq 46 \text{ mm}$

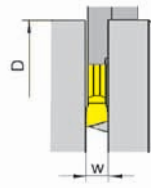

$w = 0,5 - 6,3 \text{ mm}$
 $D = 12 \text{ mm}$
 $t_{\text{max}} = 8 \text{ mm}$

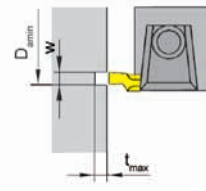

$w = 1,5 - 3 \text{ mm}$
 $t_{\text{max}} = 3 \text{ mm}$
 $D_{\text{amin}} = 20 \text{ mm}$

Klemmhalter
 Toolholder

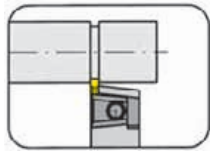

Seite/Page
 N4-N8, N18-N19

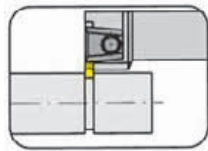

Seite/Page
 N13

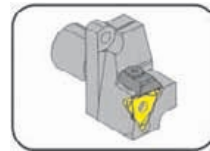

Seite/Page
 N14



Seite/Page
 N15-N16



Seite/Page
 N17

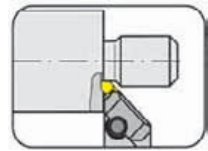

Seite/Page
 N20

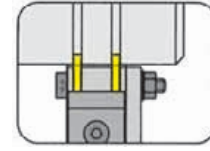

Seite/Page
 N21

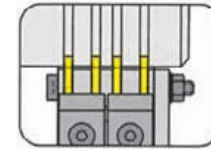

Seite/Page
 N22

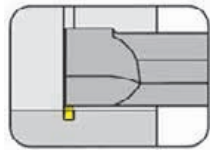

Seite/Page
 N23

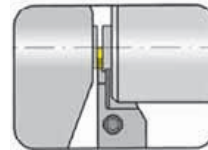

Seite/Page
 N9-N12

Wendeschneidplatte
 Indexable insert
 S312



Seite/Page
 N24

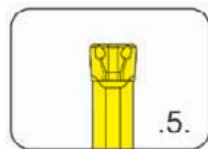

Seite/Page
 N25



Seite/Page
 N26

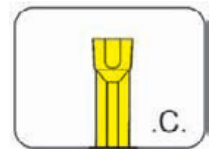

Seite/Page
 N27

Wendeschneidplatte
 Indexable insert
 312

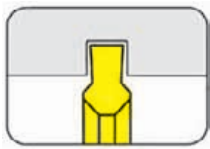

Seite/Page
 N28-N32

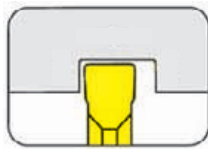

Seite/Page
 N33-N34

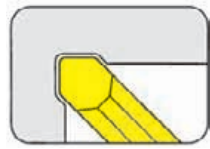

Seite/Page
 N35-N36

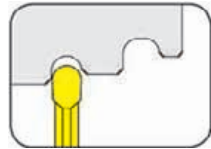

Seite/Page
 N37

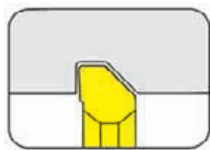

Seite/Page
 N38-N39

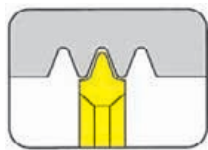

Seite/Page
 N40

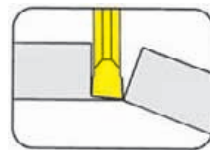

Seite/Page
 N41-N44

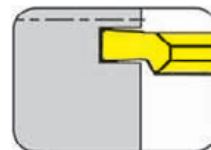

Seite/Page
 N45

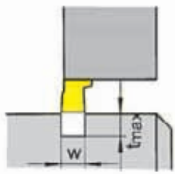

$w = 0,5 - 7,5 \text{ mm}$
 $t_{\text{max}} = 5 \text{ mm}$



$w = 0,5 - 3,5 \text{ mm}$
 $t_{\text{max}} = 5 \text{ mm}$
 $D \geq 43 \text{ mm}$

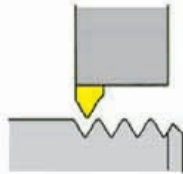

metr. Trapezgewinde
metric trapezoidal thread

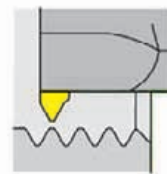

metr. Trapezgewinde
metric trapezoidal thread

Klemmhalter
Toolholder
356/357/333

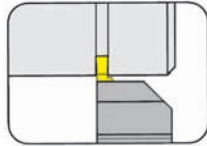

Seite/Page
O3-O6, O9

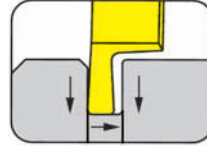

Seite/Page
O16

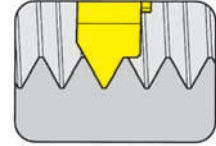

Seite/Page
O24

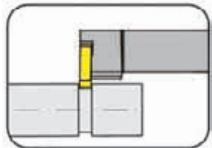

Seite/Page
O7-O8



Seite/Page
O17

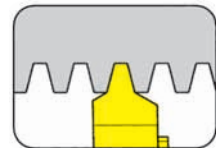

Seite/Page
O26

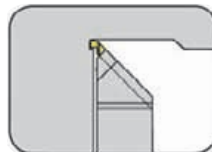

Seite/Page
O10

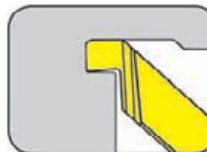

Seite/Page
O18, O20

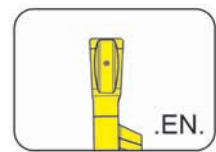

Seite/Page
O28

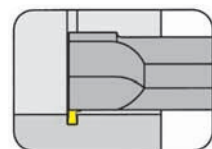

Seite/Page
O11



Seite/Page
O19

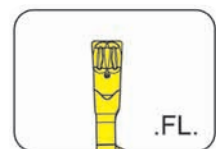

Seite/Page
O29

Kurzklemmhalter
Cartridge
357

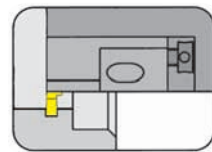

Seite/Page
O12

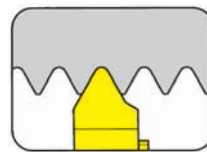

Seite/Page
O21

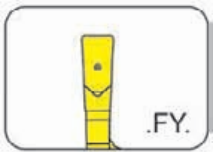

Seite/Page
O30

Wendescheidplatte
Indexable insert
315/LA315/A315/
S315

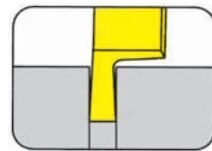

Seite/Page
O14

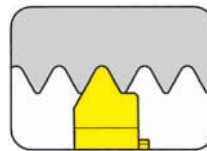

Seite/Page
O22, O25

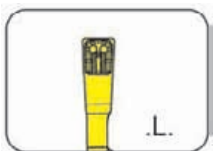

Seite/Page
O31

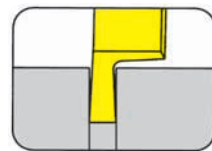

Seite/Page
O15

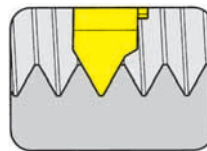

Seite/Page
O23

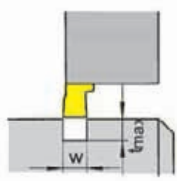

$w = 1,5 - 3,0 \text{ mm}$
 $t_{\text{max}} = 8,0 \text{ mm}$

Klemmhalter
 Toolholder
 H316/HC316

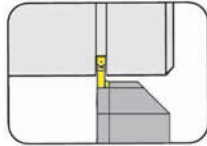

Seite/Page
 P3-P4, P10

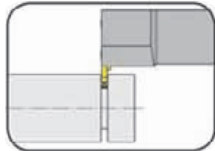

Seite/Page
 P5, P11

Kassette
 Cassette
 NK316

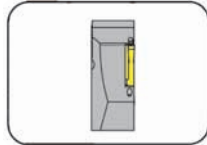

Seite/Page
 P6, P12

Wendeschneidplatte
 Indexable insert
 S316

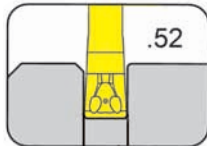

Seite/Page
 P7

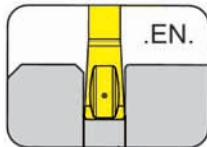

Seite/Page
 P8

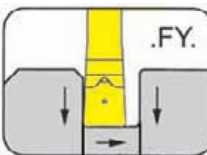

Seite/Page
 P9

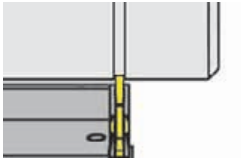

$w = 0,5 - 3,0 \text{ mm}$
 $t_{\text{max}} = 5,5 \text{ mm}$

Klemmhalter
 Toolholder
H64T

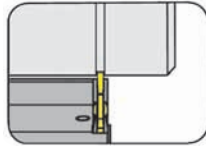

Seite/Page
 Q3-Q4

Wendeschneidplatte
 Indexable insert
S64T

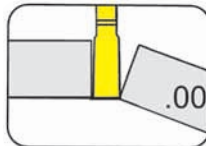

Seite/Page
 Q5

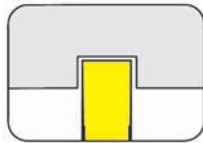

Seite/Page
 Q6

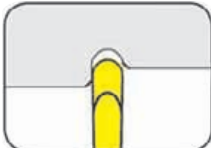

Seite/Page
 Q7

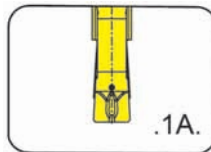

Seite/Page
 Q8

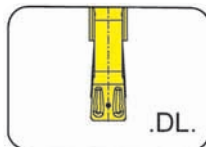

Seite/Page
 Q9

Q

100/101



**Schneidenträger
mit Schneidplatten**

Stechbreite 1,2 - 16 mm

Stechtiefe bis 55 mm

**Cutter Body
with Inserts**

Width of groove 1,2 - 16 mm

Depth of groove up to 55 mm

Klemmhalter
Toolholder
H100



Seite/Page
A3-A5

Klemmhalter
Klemmhalter
H101

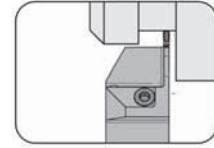

Seite/Page
A28

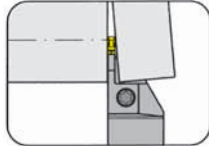

Seite/Page
A6-A12, A14, A24-A25

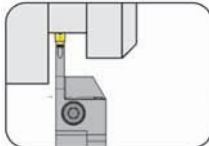

Seite/Page
A13, A15-A16

Kassette
Cassette
NK100

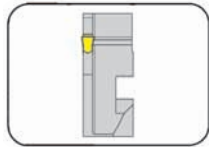

Seite/Page
A17

Schneidplatte
Insert
S100/S101

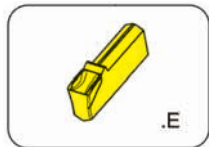

Seite/Page
A18

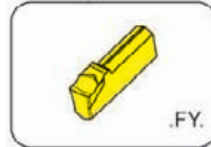

Seite/Page
A21



Seite/Page
A29

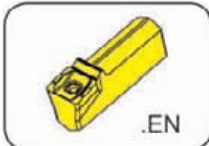

Seite/Page
A19, A26

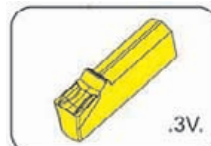

Seite/Page
A22, A27

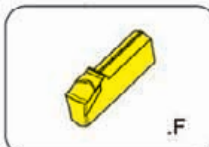

Seite/Page
A20

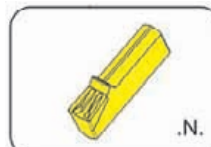

Seite/Page
A23

Klemmhalter

Toolholder

H100

mit Selbstklemmung
with self clamping

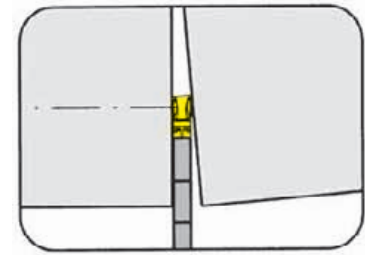

Stechtiefe bis
Stechbreite

Depth of groove up to
Width of groove

55 mm
2,0 - 5,0 mm

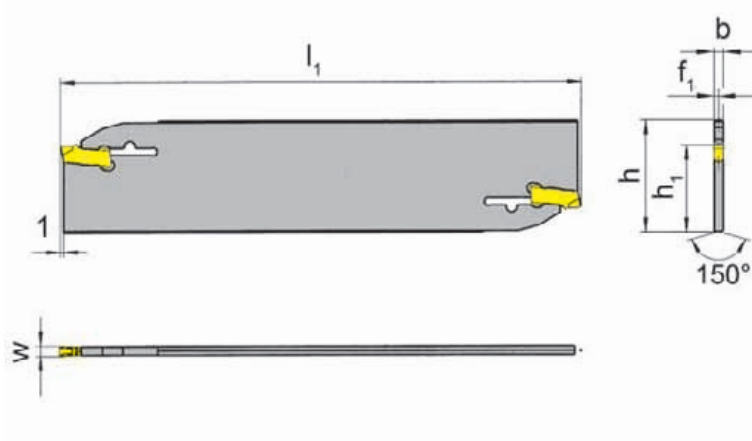

für Schneidplatte
for Insert

Typ S100
Type

Bestellnummer Part number	h	b	l_1	h_1	f_1	t_{max}	Größe Size
H100.2601.01	26	1,5	110	21,4	0,75	25,0	01
H100.3201.01	32	1,5	150	24,8	0,75	25,0	01
H100.2602.02	26	1,9	110	21,4	0,95	37,5	02
H100.3202.02	32	1,9	150	24,8	0,95	50,0	02
H100.2603.03	26	2,3	110	21,4	1,15	37,5	03
H100.3203.03	32	2,3	150	24,8	1,15	50,0	03
H100.2604.04	26	3,1	110	21,8	1,65	40,0	04
H100.3204.04	32	3,1	160	24,8	1,65	55,0	04
H100.3205.05	32	3,9	160	24,8	2,00	55,0	05

Weitere Abmessungen auf Anfrage
Further sizes upon request

w siehe Schneidplatten
w see inserts

Abmessungen in mm
Dimensions in mm

Hinweis:

Der Schlüssel **P39L** gehört nicht zum Lieferumfang des Schneidträgers. Bitte separat bestellen!

Note:

Wrench **P39L** is not combined with blade - separate order required!

A Einstechen und Abstechen

Grooving and Parting Off



Klemmhalter **H100**

Toolholder

Stechbreite	Width of groove	8,0 - 12,0 mm
-------------	-----------------	---------------

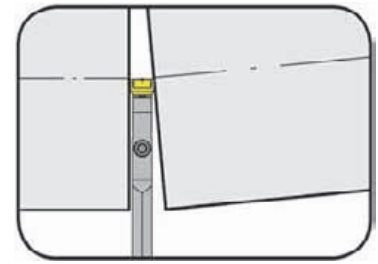

für Schneidplatte
for Insert

Typ S100
Type

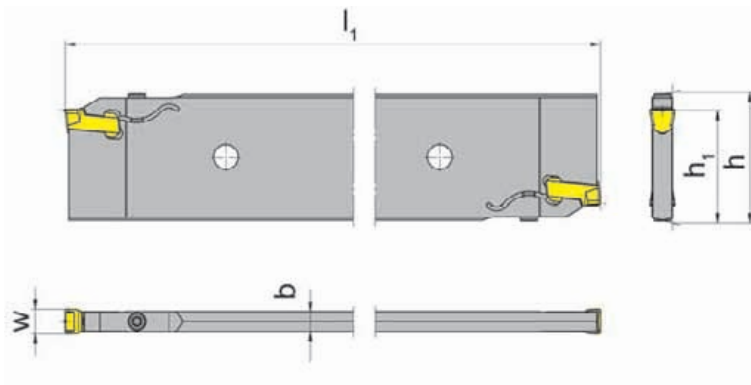

Bestellnummer Part number	h	b	l ₁	h ₁	Schneidbreite Width of groove
H100.5208.26.08	52,6	7,4	260	45	8
H100.5210.26.10	52,6	8,2	260	45	10
H100.5212.26.12	52,6	10,4	260	45	12

Weitere Abmessungen auf Anfrage
Further sizes upon request

Abmessungen in mm
Dimensions in mm

Das Anzugsdrehmoment der Schrauben finden Sie in den Technischen Hinweisen.
For torque specification of the screw, please see Technical Instructions.

Ersatzteile

Spare Parts

Klemmhalter Toolholder	Spannschraube Screw	TORX PLUS®-Schlüssel TORX PLUS® Wrench
H100...	5.13 T20P	T20PQ

Einstechen und Abstechen

Grooving and Parting Off



A

Klemmhalter

Toolholder

H100

mit Selbstklemmung
with self clamping

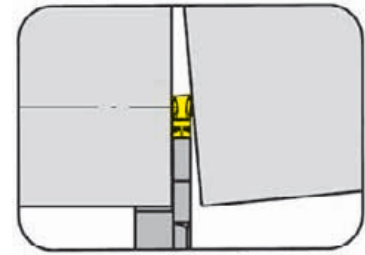

Stechtiefe bis
Stechbreite

Depth of groove up to
Width of groove

34 mm
2,0 - 4,0 mm

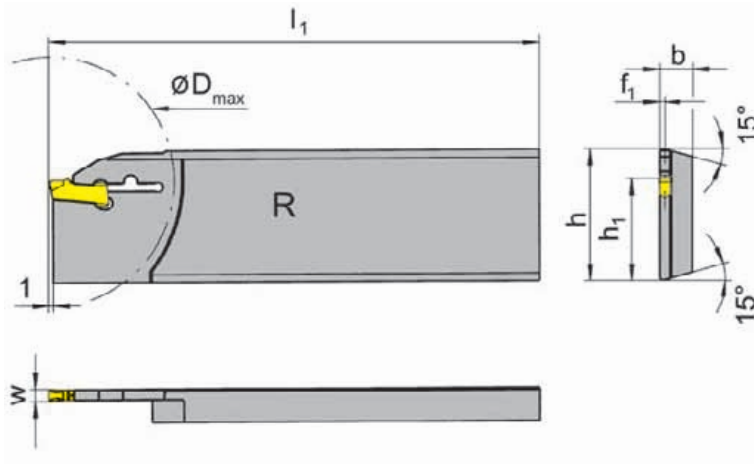

für Schneidplatte
for Insert

Typ S100
Type

R = rechts wie gezeichnet
R = right hand version shown

L = links spiegelbildlich
L = left hand version

Bestellnummer Part number	h	b	l ₁	h ₁	f ₁	t _{max}	D _{max}	Größe Size
R/LH100.2608.31	26	7,9	110	21,4	0,75	21	42	01
R/LH100.2608.32	26	7,9	110	21,4	0,95	25	50	02
R/LH100.2608.33	26	7,9	110	21,4	1,15	25	50	03
R/LH100.2608.34	26	7,9	110	21,4	1,55	25	50	04
R/LH100.3208.31	32	7,9	112	24,8	0,75	25	50	01
R/LH100.3208.32	32	7,9	112	24,8	0,95	34	68	02
R/LH100.3208.33	32	7,9	112	24,8	1,15	34	68	03
R/LH100.3208.34	32	7,9	112	24,8	1,55	34	68	04

Ausführung R oder L angeben
State R or L version

w siehe Schneidplatten
w see inserts

Abmessungen in mm
Dimensions in mm

Weitere Abmessungen auf Anfrage
Further sizes upon request

Hinweis:

Der Schlüssel **P39L** gehört nicht zum Lieferumfang des Schneidenträgers. Bitte separat bestellen!

Note:

Wrench **P39L** is not combined with blade - separate order required!

Empfohlen auf Maschinen der Firma Traub Typ:
Recommended for Traub machines type:

R/L100.2608.31-34

R/LH100.3208.31-34

TNC 30
TNM 28
TNS 26
TNS 30/42
TNA 300
TNK 28/36
TNL 26

TNC 42/65
TNM 42/65
TNS 65
TNS 60
TNA 400
TNA 300

Klemmhalter

Toolholder

H100

mit Schraubklemmung
with screwed clamping

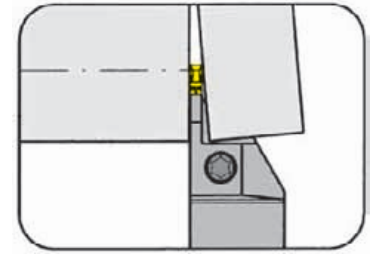

Stechtiefe bis
Stechbreite

Depth of groove up to
Width of groove

21 mm
2 mm

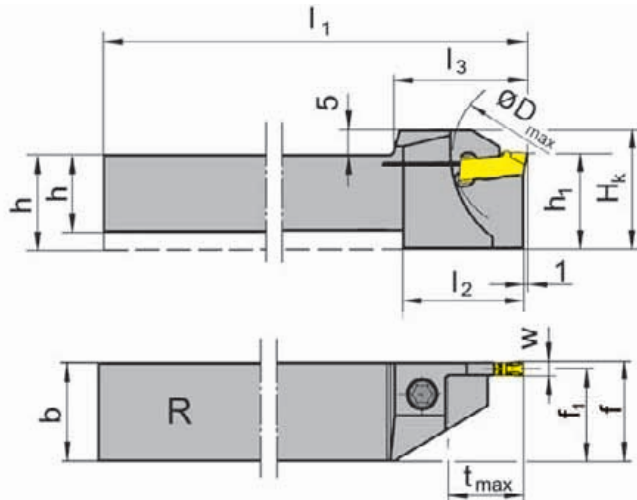

für Schneidplatte
for Insert

Typ S100
Type

R = rechts wie gezeichnet
R = right hand version shown

L = links spiegelbildlich
L = left hand version

Bestellnummer Part number	h	b	l ₁	l ₂	l ₃	h ₁	f ₁	f	t _{max}	D _{max}	H _K	Größe Size
R/LH100.1010.01	10	10	125	19	21,0	13	9,25	f ₁ +w/2	10,5	21	18	01
R/LH100.1010.11	10	10	125	21	23,0	16	9,25	f ₁ +w/2	13,0	42	21	01
R/LH100.1212.01	12	12	125	21	23,0	16	11,25	f ₁ +w/2	13,0	26	21	01
R/LH100.1212.11	12	12	125	21	26,0	16	11,25	f ₁ +w/2	16,0	42	21	01
R/LH100.1616.11	16	16	125	24	26,0	20	15,25	f ₁ +w/2	16,0	42	25	01
R/LH100.1616.21	16	16	125	30	33,5	20	15,25	f ₁ +w/2	21,0	42	25	01
R/LH100.2020.11	20	20	125	-	33,5	20	19,25	f ₁ +w/2	16,0	42	25	01
R/LH100.2020.21	20	20	125	-	33,5	20	19,25	f ₁ +w/2	21,0	42	25	01
R/LH100.2525.21	25	25	150	-	33,5	25	24,30	f ₁ +w/2	21,0	42	30	01

Ausführung R oder L angeben
State R or L version

w siehe Schneidplatten
w see inserts

Abmessungen in mm
Dimensions in mm

Weitere Abmessungen auf Anfrage
Further sizes upon request

Das Anzugsdrehmoment der Schrauben finden Sie in den Technischen Hinweisen.
For torque specification of the screw, please see Technical Instructions.

Ersatzteile

Spare Parts

Klemmhalter Toolholder	Spannschraube Screw	TORX PLUS®-Schlüssel TORX PLUS® Wrench
R/LH100...	4.15T15P	T15PQ

Einstechen und Abstechen

Grooving and Parting Off



A

Klemmhalter

Toolholder

H100

mit Schraubklemmung
with screwed clamping

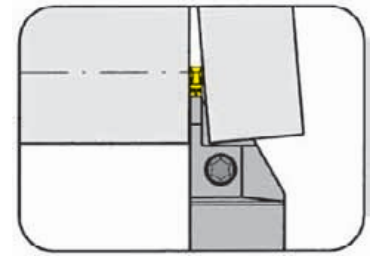

Stechtiefe bis
Stechbreite

Depth of groove up to
Width of groove

21 mm
2 mm

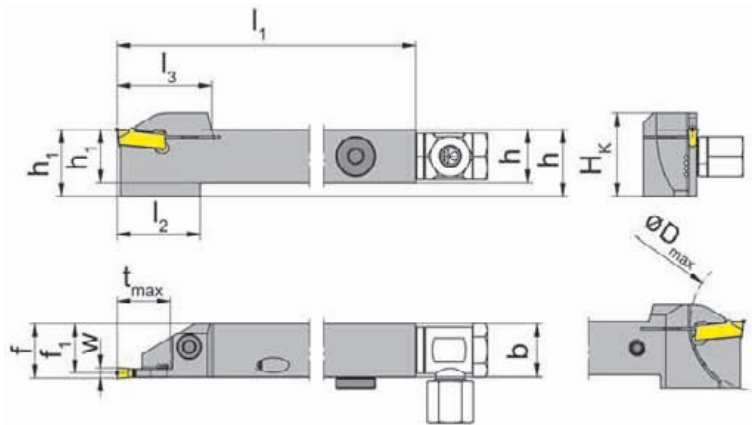

für Schneidplatte
for insert

Typ S100
Type

mit innerer
Kühlmittelzufuhr
with through coolant supply

R = rechts wie gezeichnet
R = right hand version shown

L = links spiegelbildlich
L = left hand version

Bestellnummer Part number	h	b	l ₁	l ₂	l ₃	h ₁	f ₁	f	t _{max}	D _{max}	H _K	Größe Size
R/LH100.1212.01.IK	12	12	125	21	23,0	12	11,25	f ₁ +w/2	13	26	21	01
R/LH100.1212.11.IK	12	12	125	21	26,0	12	11,25	f ₁ +w/2	16	42	21	01
R/LH100.1616.11.IK	16	16	125	24	26,0	16	15,25	f ₁ +w/2	16	42	25	01
R/LH100.1616.21.IK	16	16	125	30	33,5	16	15,25	f ₁ +w/2	21	42	25	01
R/LH100.2020.11.IK	20	20	125	-	33,5	20	19,25	f ₁ +w/2	16	42	25	01
R/LH100.2020.21.IK	20	20	125	-	33,5	20	19,25	f ₁ +w/2	21	42	25	01
R/LH100.2525.21.IK	25	25	150	-	33,5	25	24,30	f ₁ +w/2	21	42	30	01

Ausführung R oder L angeben
State R or L version

w siehe Schneidplatten
w see inserts

Abmessungen in mm
Dimensions in mm

Weitere Abmessungen auf Anfrage
Further sizes upon request

Das Anzugsdrehmoment der Schrauben finden Sie in den Technischen Hinweisen.
For torque specification of the screw, please see Technical Instructions.

Ersatzteile

Spare Parts

Klemmhalter Toolholder	Spannschraube Screw	Kühlmittelanschluss Coolant supply	TORX PLUS®-Schlüssel TORX PLUS® Wrench	Dichtstopfen Sealing plug
R/LH100.1212...	4.15T15P	004.00.61	T15PQ	
R/LH100...	4.15T15P	004.00.16	T15PQ	004.00.26

Klemmhalter Toolholder

H100

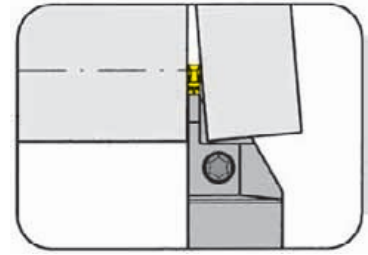

Stechtiefe bis Stechbreite	Depth of groove up to Width of groove	32,5 mm 2,5 mm
-------------------------------	--	-------------------

für Schneidplatte
for Insert

Typ S100
Type

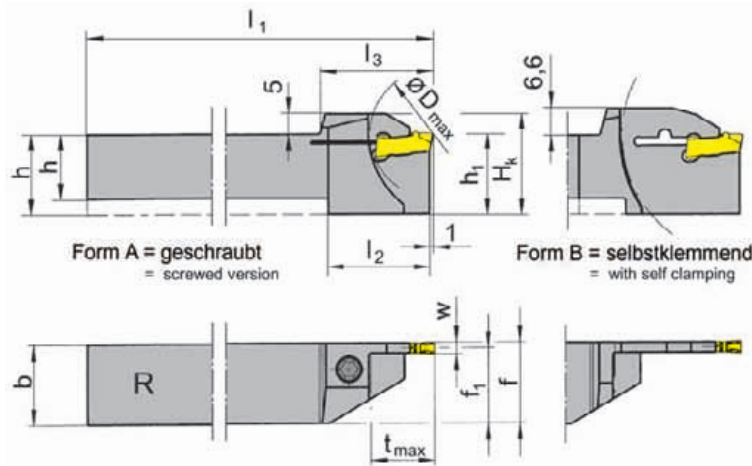

R = rechts wie gezeichnet
R = right hand version shown

L = links spiegelbildlich
L = left hand version

Bestellnummer Part number	h	b	l ₁	l ₂	l ₃	h ₁	f ₁	f	t _{max}	D _{max}	H _K	Form Form	Größe Size
R/LH100.1212.02	12	12	125	21	23,0	16	11,05	f ₁ +w/2	13,0	25	21,0	A	02
R/LH100.1616.02	16	16	125	19	21,0	20	15,05	f ₁ +w/2	10,5	42	25,0	A	02
R/LH100.1212.12	12	12	125	24	26,0	16	11,05	f ₁ +w/2	16,0	42	25,0	A	02
R/LH100.1616.12	16	16	125	24	26,0	20	15,05	f ₁ +w/2	16,0	42	25,0	A	02
R/LH100.2020.12	20	20	125	-	26,0	20	19,05	f ₁ +w/2	16,0	42	25,0	A	02
R/LH100.1616.22	16	16	125	30	33,5	20	15,05	f ₁ +w/2	21,0	42	25,0	A	02
R/LH100.2020.22	20	20	125	-	33,5	20	19,05	f ₁ +w/2	21,0	42	25,0	A	02
R/LH100.2525.22	25	25	150	-	33,5	25	24,05	f ₁ +w/2	21,0	42	30,0	A	02
R/LH100.2020.32	20	20	125	35	38,5	25	19,05	f ₁ +w/2	32,5	65	31,6	B	02

Ausführung R oder L angeben
State R or L version

w siehe Schneidplatten
w see inserts

Abmessungen in mm
Dimensions in mm

Weitere Abmessungen auf Anfrage
Further sizes upon request

Bestellhinweis:

Der Schlüssel **P39L** gehört nicht zum Lieferumfang des Schneidenträgers R/LH100.2020.32. Bitte separat bestellen!

Ordering note:

Wrench **P39L** ist not combined with blade R/LH100.2020.32 - separate order required!

Das Anzugsdrehmoment der Schrauben finden Sie in den Technischen Hinweisen.

For torque specification of the screw, please see Technical Instructions.

Ersatzteile Spare Parts

Klemmhalter Toolholder	Spannschraube Screw	TORX PLUS®-Schlüssel TORX PLUS® Wrench	Spannschlüssel Wrench
R/LH100...	4.15T15P	T15PQ	-
R/LH100.2020.32	-	-	P39L

Einstechen und Abstechen

Grooving and Parting Off



A

Klemmhalter

Toolholder

H100

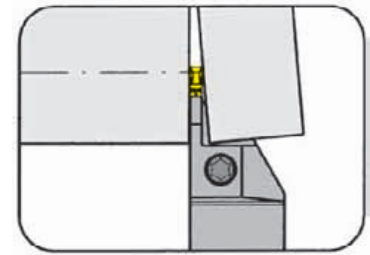

Stechtiefe bis
Stechbreite

Depth of groove up to
Width of groove

21 mm
2,5 mm

für Schneidplatte
for Insert

Typ S100
Type

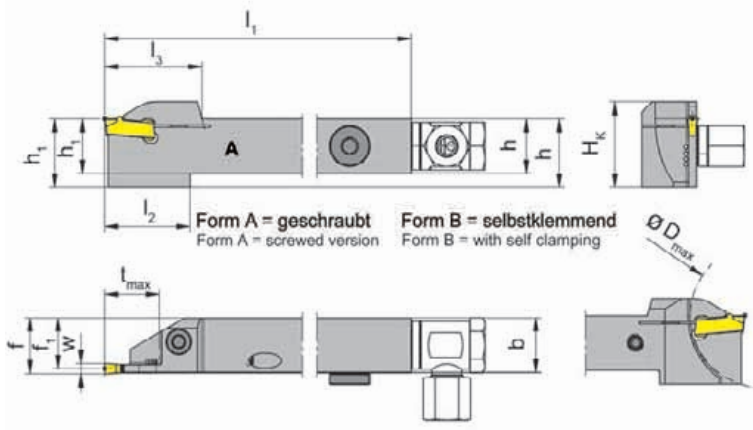

R = rechts wie gezeichnet
R = right hand version shown

L = links spiegelbildlich
L = left hand version

mit innerer
Kühlmittelzufuhr
with through coolant supply

Bestellnummer Part number	h	b	l ₁	l ₂	l ₃	h ₁	f ₁	f	t _{max}	D _{max}	H _k	Form Form	Größe Size
R/LH100.1212.02.IK	12	12	125	21	23,0	16	11,05	f ₁ +w/2	13,0	25	21	A	02
R/LH100.1616.02.IK	16	16	125	19	21,0	20	15,05	f ₁ +w/2	10,5	42	25	A	02
R/LH100.1212.12.IK	12	12	125	24	26,0	16	11,05	f ₁ +w/2	16,0	42	25	A	02
R/LH100.1616.12.IK	16	16	125	24	28,5	20	15,05	f ₁ +w/2	16,0	42	25	A	02
R/LH100.2020.12.IK	20	20	125	-	26,0	20	19,05	f ₁ +w/2	16,0	42	25	A	02
R/LH100.1616.22.IK	16	16	125	30	33,5	20	15,05	f ₁ +w/2	21,0	42	25	A	02
R/LH100.2020.22.IK	20	20	125	-	33,5	20	19,05	f ₁ +w/2	21,0	42	25	A	02
R/LH100.2525.22.IK	25	25	150	-	33,5	25	24,05	f ₁ +w/2	21,0	42	30	A	02

Ausführung R oder L angeben
State R or L version

w siehe Schneidplatten
w see inserts

Abmessungen in mm
Dimensions in mm

Weitere Abmessungen auf Anfrage
Further sizes upon request

Das Anzugsdrehmoment der Schrauben finden Sie in den Technischen Hinweisen.
For torque specification of the screw, please see Technical Instructions.

Ersatzteile

Spare Parts

Klemmhalter Toolholder	Spannschraube Screw	Kühlmittelanschluss Coolant supply	TORX PLUS®-Schlüssel TORX PLUS® Wrench	Dichtstopfen Sealing plug
R/LH100.1212...	4.15T15P	004.00.61	T15PQ	
R/LH100.1616.02.IK	4.15T15P	004.00.61	T15PQ	004.00.26
R/LH100.1616.22.IK	4.15T15P	004.00.16	T15PQ	004.00.26
R/LH100.2020.22.IK	5.17T20P	004.00.16	T20PQ	004.00.26
R/LH100.2525.22.IK	4.15T15P	004.00.16	T15PQ	004.00.26

Klemmhalter **H100**

Toolholder

Stechtiefe bis Stechbreite	Depth of groove up to Width of groove	32,5 mm 3,0 mm
-------------------------------	--	-------------------

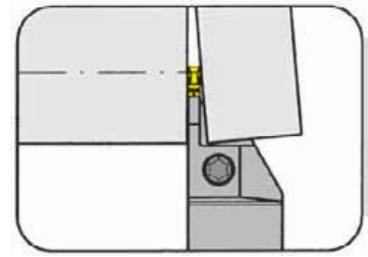

für Schneidplatte
for Insert

Typ S100
Type

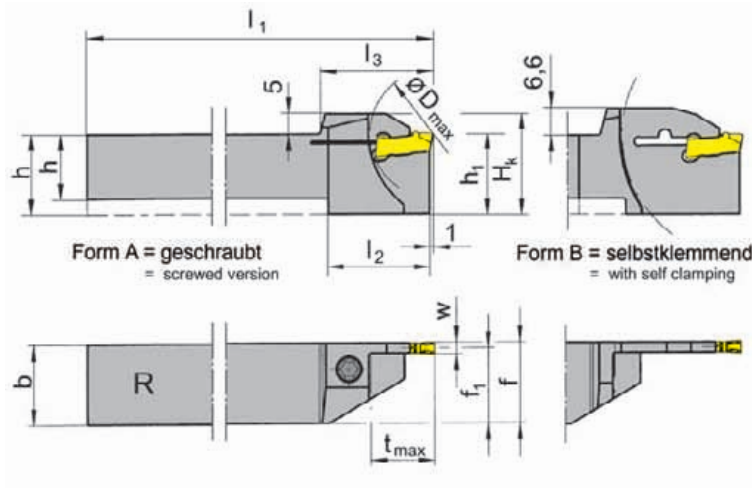

R = rechts wie gezeichnet
R = right hand version shown

L = links spiegelbildlich
L = left hand version

Bestellnummer Part number	h	b	l ₁	l ₂	l ₃	h ₁	f ₁	f	t _{max}	D _{max}	H _K	Form Form	Größe Size
R/LH100.1212.03	12	12	125	21,0	23,0	16	10,85	f ₁ +w/2	13,0	26	25,0	A	03
R/LH100.1616.03	16	16	125	19,5	23,0	20	14,85	f ₁ +w/2	10,5	42	25,0	A	03
R/LH100.1616.13	16	16	125	25,0	28,5	20	14,85	f ₁ +w/2	16,0	42	25,0	A	03
R/LH100.2020.13	20	20	125	-	28,5	20	18,85	f ₁ +w/2	16,0	42	25,0	A	03
R/LH100.2525.13	25	25	150	-	28,5	25	23,85	f ₁ +w/2	16,0	42	30,0	A	03
R/LH100.1616.23	16	16	125	30,0	33,5	20	14,85	f ₁ +w/2	21,0	42	25,0	A	03
R/LH100.2020.23	20	20	125	-	33,5	20	18,85	f ₁ +w/2	21,0	42	25,0	A	03
R/LH100.2525.23	25	25	150	-	33,5	25	23,85	f ₁ +w/2	21,0	42	30,0	A	03
R/LH100.2020.33	20	20	125	35,0	38,5	25	18,85	f ₁ +w/2	32,5	65	31,6	B	03
R/LH100.2525.33	25	25	150	-	38,5	25	23,85	f ₁ +w/2	32,5	65	31,6	B	03

Ausführung R oder L angeben
State R or L version

w siehe Schneidplatten
w see inserts

Abmessungen in mm
Dimensions in mm

Weitere Abmessungen auf Anfrage
Further sizes upon request

Bestellhinweis:

Der Schlüssel **P39L** gehört nicht zum Lieferumfang des Schneidenträgers R/LH100...33. Bitte separat bestellen!

Ordering note:

Wrench **P39L** ist not combined with blade R/LH100...33 - separate order required!

Das Anzugsdrehmoment der Schrauben finden Sie in den Technischen Hinweisen.

For torque specification of the screw, please see Technical Instructions.

Ersatzteile
Spare Parts

Klemmhalter Toolholder	Spannschraube Screw	TORX PLUS®-Schlüssel TORX PLUS® Wrench	Spannschlüssel Wrench
R/LH100...	4.15T15P	T15PQ	-
R/LH100...33	-	-	P39L

Klemmhalter

Toolholder

H100

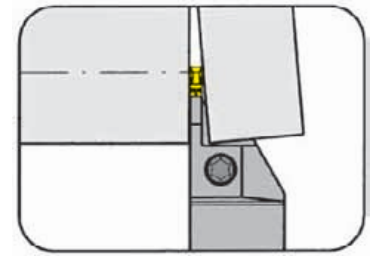

Stechtiefe bis Stechbreite	Depth of groove up to Width of groove	32,5 mm 3,0 mm
-------------------------------	--	-------------------

für Schneidplatte
for Insert

Typ S100
Type

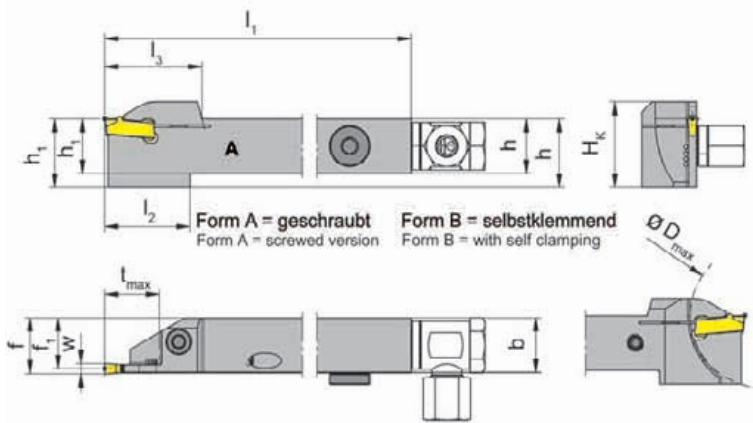

R = rechts wie gezeichnet
R = right hand version shown

L = links spiegelbildlich
L = left hand version

mit innerer
Kühlmittelzufuhr
with through coolant supply

Bestellnummer Part number	h	b	l ₁	l ₂	l ₃	h ₁	f ₁	f	t _{max}	D _{max}	H _k	Form Form	Größe Size
R/LH100.1212.03.IK	12	12	125	21,0	23,0	16	10,85	f ₁ +w/2	13,0	26	25,0	A	03
R/LH100.1616.03.IK	16	16	125	19,5	23,0	20	14,85	f ₁ +w/2	10,5	42	25,0	A	03
R/LH100.1616.13.IK	16	16	125	25,0	28,5	20	14,85	f ₁ +w/2	16,0	42	25,0	A	03
R/LH100.2020.13.IK	20	20	125	-	28,5	20	18,85	f ₁ +w/2	16,0	42	25,0	A	03
R/LH100.2525.13.IK	25	25	150	-	28,5	25	23,85	f ₁ +w/2	16,0	42	30,0	A	03
R/LH100.1616.23.IK	16	16	125	30,0	33,5	20	14,85	f ₁ +w/2	21,0	42	25,0	A	03
R/LH100.2020.23.IK	20	20	125	-	33,5	20	18,85	f ₁ +w/2	21,0	42	25,0	A	03
R/LH100.2525.23.IK	25	25	150	-	33,5	25	23,85	f ₁ +w/2	21,0	42	30,0	A	03
R/LH100.2020.33.IK	20	20	125	35,0	38,5	25	18,85	f ₁ +w/2	32,5	65	31,6	B	03
R/LH100.2525.33.IK	25	25	150	-	38,5	25	23,85	f ₁ +w/2	32,5	65	31,6	B	03

Ausführung R oder L angeben
State R or L version

w siehe Schneidplatten
w see inserts

Abmessungen in mm
Dimensions in mm

Weitere Abmessungen auf Anfrage
Further sizes upon request

Hinweis:

Der Schlüssel **P39L** gehört nicht zum Lieferumfang des Schneidenträgers. Bitte separat bestellen!

Note:

Wrench **P39L** ist not combined with blade - separate order required!

Das Anzugsdrehmoment der Schrauben finden Sie in den Technischen Hinweisen.

For torque specification of the screw, please see Technical Instructions.

Ersatzteile

Spare Parts

Klemmhalter Toolholder	Spannschraube Screw	Kühlmittelanschluss Coolant supply	TORX PLUS®- Schlüssel TORX PLUS® Wrench	Dichtstopfen Sealing plug	Spann- schlüssel Wrench
R/LH100.1212.../..2525.23...	5.17T20P	004.00.61	T20PQ	-	-
R/LH100...	5.17T20P	004.00.16	T20PQ	004.00.26	-
R/LH100...33.IK	-	004.00.16	-	004.00.26	P39L

Klemmhalter **H100**

Toolholder

Stechtiefe bis	Depth of groove up to	40,5 mm
Stechbreite	Width of groove	4,0 mm

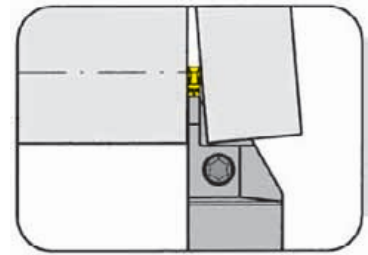

für Schneidplatte
for Insert

Typ S100
Type

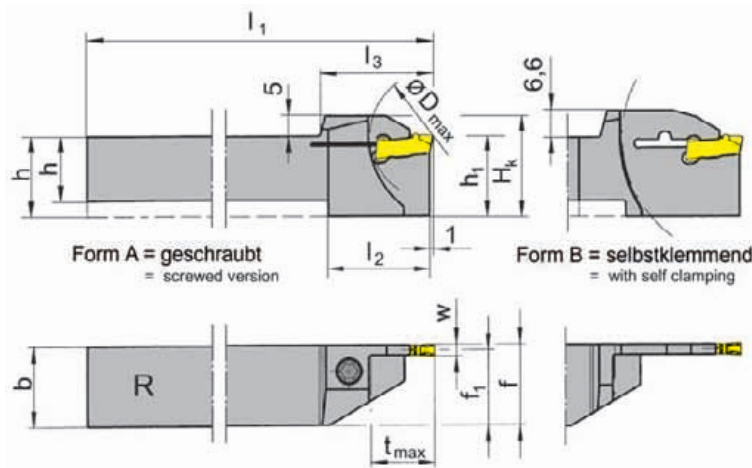

R = rechts wie gezeichnet
R = right hand version shown

L = links spiegelbildlich
L = left hand version

Bestellnummer Part number	h	b	l ₁	l ₂	l ₃	h ₁	f ₁	f	t _{max}	D _{max}	H _K	Form Form	Größe Size
R/LH100.1616.04	16	16	125	19,5	23,0	20	14,45	f ₁ +w/2	10,5	42	25,0	A	04
R/LH100.1616.14	16	16	125	25,0	28,5	20	14,45	f ₁ +w/2	16,0	42	25,0	A	04
R/LH100.2020.14	20	20	125	-	28,5	20	18,45	f ₁ +w/2	16,0	42	25,0	A	04
R/LH100.2525.14	25	25	150	-	28,5	25	23,45	f ₁ +w/2	16,0	42	30,0	A	04
R/LH100.1616.24	16	16	125	30,0	33,5	20	14,45	f ₁ +w/2	21,0	42	25,0	A	04
R/LH100.2020.34	20	20	125	35,0	38,5	25	18,45	f ₁ +w/2	32,5	65	31,6	B	04
R/LH100.2525.34	25	25	150	40,0	46,5	32	23,45	f ₁ +w/2	40,5	81	31,6	B	04

Ausführung R oder L angeben
State R or L version

w siehe Schneidplatten
w see inserts

Abmessungen in mm
Dimensions in mm

Weitere Abmessungen auf Anfrage
Further sizes upon request

Bestellhinweis:

Der Schlüssel **P39L** gehört nicht zum Lieferumfang des Schneidenträgers R/LH100...34. Bitte separat bestellen!

Ordering note:

Wrench **P39L** ist not combined with blade R/LH100...34 - separate order required!

Das Anzugsdrehmoment der Schrauben finden Sie in den Technischen Hinweisen.

For torque specification of the screw, please see Technical Instructions.

Ersatzteile

Spare Parts

Klemmhalter Toolholder	Spannschraube Screw	TORX PLUS®-Schlüssel TORX PLUS® Wrench	Spannschlüssel Wrench
R/LH100...	4.15T15P	T15PQ	-
R/LH100...34	-	-	P39L

Einstechen und Abstechen

Grooving and Parting Off



A

Klemmhalter

Toolholder

H100

mit Schraubklemmung
with screwed clamping

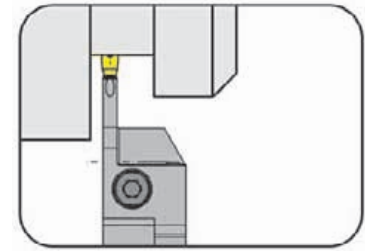

Stechtiefe bis
Stechbreite

Depth of groove up to
Width of groove

21,5 mm
3,0 - 4,0 mm

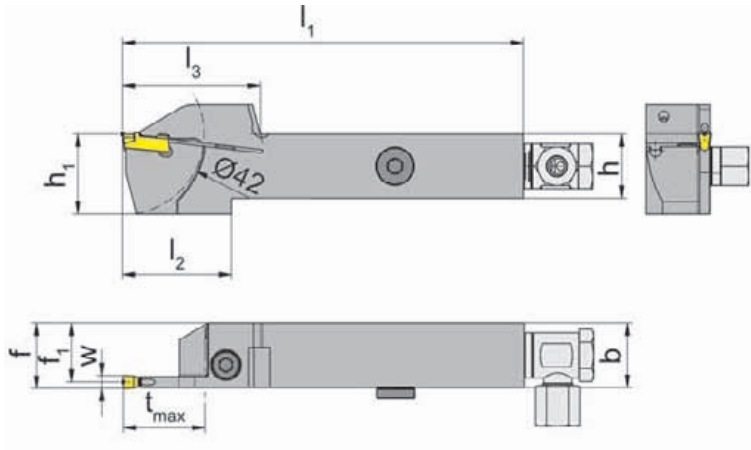

für Schneidplatte
for Insert

Typ S100
Type

mit innerer
Kühlmittelzufuhr
with through coolant supply

R = rechts wie gezeichnet
R = right hand version shown

L = links spiegelbildlich
L = left hand version

Bestellnummer Part number	h	b	l ₁	l ₂	l ₃	h ₁	f ₁	f	t _{max}	Größe Size
R/LH100.1616.0.23.IK	16	20	125	35	39	25	14,65	f ₁ +w/2	21,5	03
R/LH100.1616.0.24.IK	16	20	125	35	39	25	14,30	f ₁ +w/2	21,5	04
R/LH100.2020.0.23.IK	20	20	125	33	39	25	18,65	f ₁ +w/2	21,5	03
R/LH100.2020.0.24.IK	20	20	125	33	39	25	18,30	f ₁ +w/2	21,5	04
R/LH100.2525.0.23.IK	25	25	150	33	39	30	23,65	f ₁ +w/2	21,5	03
R/LH100.2525.0.24.IK	25	25	150	33	39	30	23,30	f ₁ +w/2	21,5	04

Ausführung R oder L angeben
State R or L version

w siehe Schneidplatten
w see inserts

Abmessungen in mm
Dimensions in mm

Weitere Abmessungen auf Anfrage
Further sizes upon request

Das Anzugsdrehmoment der Schrauben finden Sie in den Technischen Hinweisen.
For torque specification of the screw, please see Technical Instructions.

Ersatzteile

Spare Parts

Klemmhalter Toolholder	Dichtstopfen Sealing plug	Kühlmittelanschluss Coolant supply	Spannschraube Screw	TORX PLUS®-Schlüssel TORX PLUS® Wrench
R/LH100...	004.00.26	004.00.16	6.23 T25P	T 25 PQ

Klemmhalter Toolholder

H100

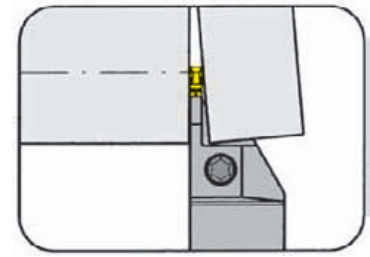

Stechtiefe bis Stechbreite	Depth of groove up to Width of groove	40,5 mm 5,0 mm
-------------------------------	--	-------------------

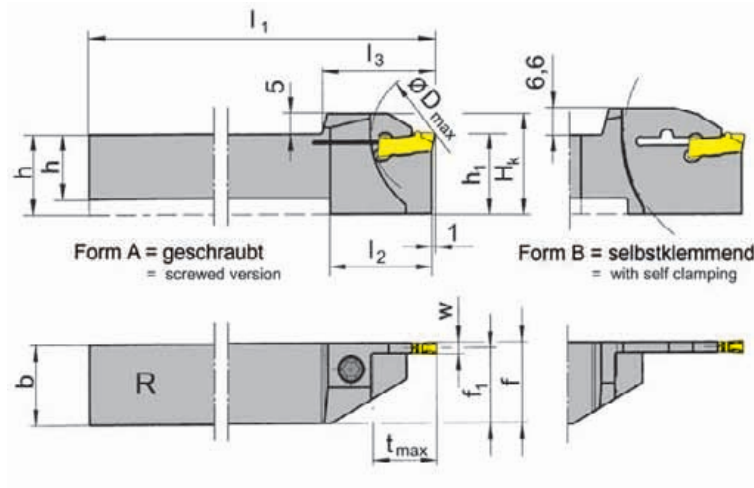

für Schneidplatte
for Insert

Typ S100
Type

R = rechts wie gezeichnet
R = right hand version shown

L = links spiegelbildlich
L = left hand version

Bestellnummer Part number	h	b	l ₁	l ₂	l ₃	h ₁	f ₁	f	t _{max}	D _{max}	H _K	Form Form	Größe Size
R/LH100.2020.15	20	20	125	-	28,5	20	18,05	f ₁ +w/2	16,0	42	25,0	A	05
R/LH100.2525.15	25	25	150	-	28,5	25	23,05	f ₁ +w/2	16,0	42	30,0	A	05
R/LH100.2020.35	20	20	125	35	38,5	25	18,05	f ₁ +w/2	32,5	65	31,6	B	05
R/LH100.2525.35	25	25	150	40	46,5	32	23,05	f ₁ +w/2	40,5	81	38,6	B	05

Ausführung R oder L angeben
State R or L version

w siehe Schneidplatten
w see inserts

Abmessungen in mm
Dimensions in mm

Weitere Abmessungen auf Anfrage
Further sizes upon request

Bestellhinweis:

Der Schlüssel **P39L** gehört nicht zum Lieferumfang des Schneidenträgers. Bitte separat bestellen!

Ordering note:

Wrench **P39L** ist not combined with blade - separate order required!

Das Anzugsdrehmoment der Schrauben finden Sie in den Technischen Hinweisen.

For torque specification of the screw, please see Technical Instructions.

Ersatzteile Spare Parts

Klemmhalter Toolholder	Spannschraube Screw	TORX PLUS®-Schlüssel TORX PLUS® Wrench	Spannschlüssel Wrench
R/LH100...	4.15T15P	T15PQ	-
R/LH100...35	-	-	P39L

Einstechen und Abstechen

Grooving and Parting Off



A

Klemmhalter

Toolholder

H100

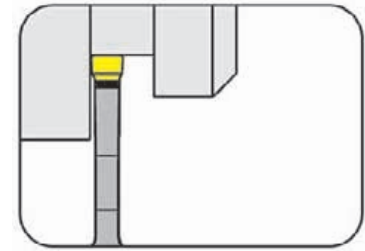

Stechtiefe bis	Depth of groove up to	41 mm
Stechbreite	Width of groove	4,0 - 12,0 mm

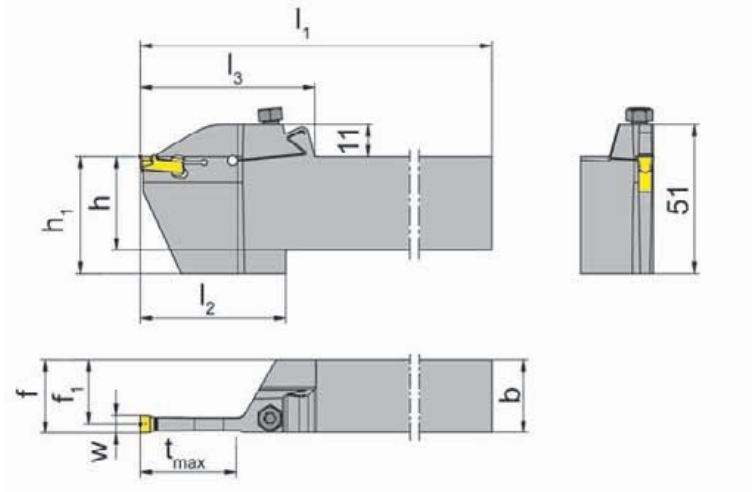

für Schneidplatte
for Insert

Typ S100
Type

R = rechts wie gezeichnet
R = right hand version shown

L = links spiegelbildlich
L = left hand version

Bestellnummer Part number	h	b	l ₁	l ₂	l ₃	h ₁	f ₁	f	t _{max}	Größe Size
R/LH100.2020.3.04	20	20	150	50	60	32	18,2	f ₁ +w/2	33	04
R/LH100.2020.3.05	20	20	150	50	60	32	17,7	f ₁ +w/2	33	05
R/LH100.2525.3.05	25	25	150	50	60	32	22,7	f ₁ +w/2	33	05
R/LH100.2525.3.06	25	25	150	50	60	40	22,2	f ₁ +w/2	33	06
R/LH100.3225.3.06	32	25	170	50	60	40	22,2	f ₁ +w/2	33	06
R/LH100.3225.3.08	32	25	170	50	60	40	21,2	f ₁ +w/2	33	08
R/LH100.3225.3.8	32	25	170	50	60	40	21,2	f ₁ +w/2	35	08
R/LH100.3225.4.08	32	25	170	55	65	40	21,2	f ₁ +w/2	41	08
R/LH100.3225.4.10	32	25	170	55	65	40	20,3	f ₁ +w/2	41	10
R/LH100.3225.4.12	32	25	170	55	65	40	19,3	f ₁ +w/2	41	12

Ausführung R oder L angeben
State R or L version

w siehe Schneidplatten
w see inserts

Abmessungen in mm
Dimensions in mm

Weitere Abmessungen auf Anfrage
Further sizes upon request

Das Anzugsdrehmoment der Schrauben finden Sie in den Technischen Hinweisen.
For torque specification of the screw, please see Technical Instructions.

Ersatzteile

Spare Parts

Klemmhalter Toolholder	Spannschraube Screw	TORX PLUS®-Schlüssel TORX PLUS® Wrench
R/LH100...	030.6075.T20P	T20PQ

Klemmhalter **H100**

Toolholder

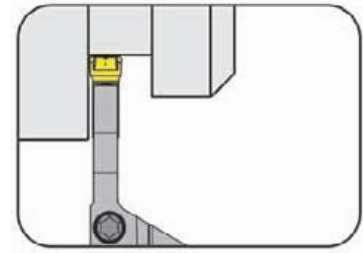

Stechtiefe bis Stechbreite	Depth of groove up to Width of groove	45 mm 16,0 mm
-------------------------------	--	------------------

für Schneidplatte
for Insert

Typ S100
Type

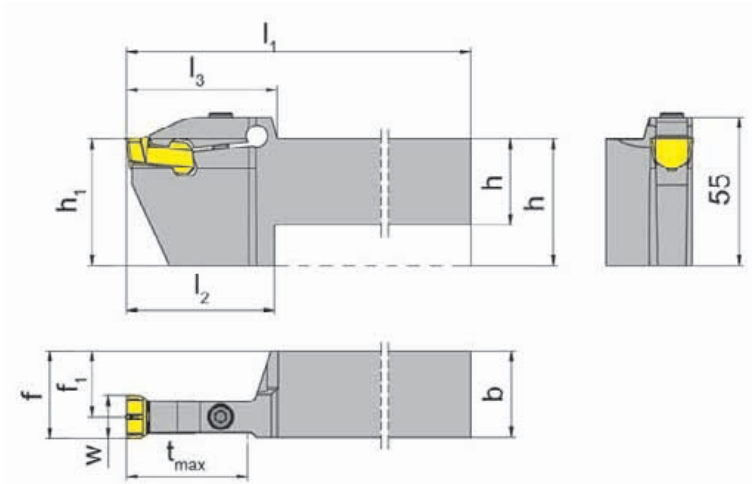

R = rechts wie gezeichnet
R = right hand version shown

L = links spiegelbildlich
L = left hand version

Bestellnummer Part number	h	b	l ₁	l ₂	h ₁	f ₁	f	t _{max}	l ₃	Größe Size
R/LH100.3232.5.16	32	32	170	55	47	24,5	f ₁ +w/2	45	56	16

Ausführung R oder L angeben
State R or L version

w siehe Schneidplatten
w see inserts

Abmessungen in mm
Dimensions in mm

Weitere Abmessungen auf Anfrage
Further sizes upon request

Das Anzugsdrehmoment der Schrauben finden Sie in den Technischen Hinweisen.
For torque specification of the screw, please see Technical Instructions.

Ersatzteile

Spare Parts

Klemmhalter Toolholder	Spannschraube Screw	TORX PLUS®-Schlüssel TORX PLUS® Wrench
R/LH100.3232.5.16	030.0625.T25P	T 25 PQ

Einstecken und Abstecken (außen)

Grooving and Parting off (external)



Kassette

Cassette

NK100

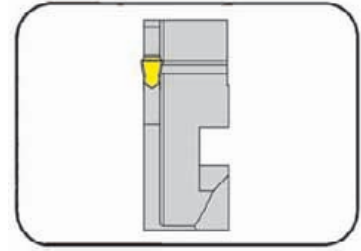

Stechtiefe bis Stechbreite	Depth of groove up to Width of groove	25 mm 2,0 - 4,0 mm
-------------------------------	--	-----------------------

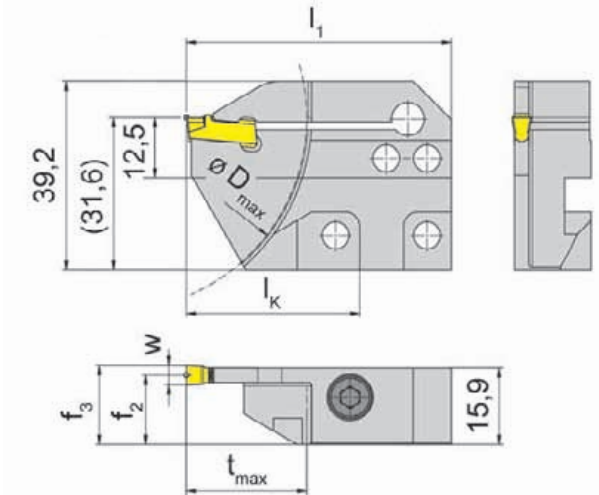

für Schneidplatte
for Insert

Typ S100
Type

L = links wie gezeichnet
L = left hand version shown

Bestellnummer Part number	l_1	t_{max}	w	f_3	f_2	D_{max}	l_k
R/LNK100.3215.21	55	25	2	$f_2+w/2$	15,4	80	36
R/LNK100.3215.23	55	25	3	$f_2+w/2$	14,9	80	36
R/LNK100.3215.24	55	25	4	$f_2+w/2$	14,4	80	36

Für Grundhalter R...K1 und L...K2
For basic toolholder R...K1 and L...K2

Abmessungen in mm
Dimensions in mm

Bestellhinweis:

Befestigungsschrauben der Kassetten gehören zum Lieferumfang des Grundhalters.

Ordering note:

The fastening screw is combined with the basic toolholder - no separate order required.

Das Anzugsdrehmoment der Schrauben finden Sie in den Technischen Hinweisen.

For torque specification of the screw, please see Technical Instructions.

Ersatzteile
Spare Parts

Kassette Cassette	Spannschraube Screw	TORX PLUS®-Schlüssel TORX PLUS® Wrench
R/LNK100...	6.23 T25P	T 25 PQ

Schneidplatte

Insert

S100

mit Spanformrille
with chip former

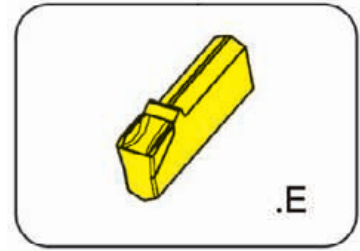

Stechbreite	Width of groove	2-5 mm
-------------	-----------------	--------

für Klemhalter
for Toolholder

Typ H100
Type

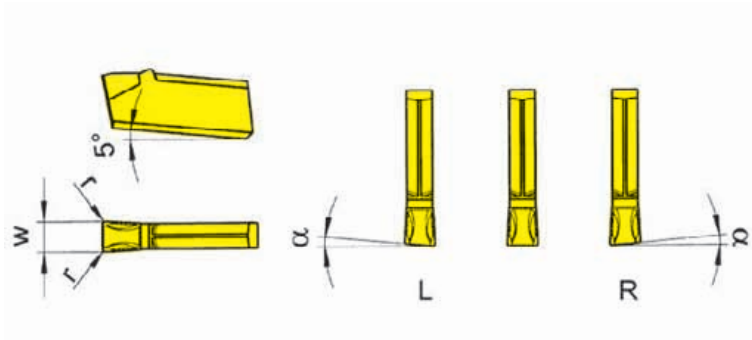

R = Rechtsausführung
R = right hand version

L = Linksausführung
L = left hand version

Bestellnummer Part number	w	r	α	Größe Size	ALX2	ALX3	AS63	AS66	TC92	TC93	TF42	TF43	TF45	TF46	Ti22
S100.0200.E2	2,0	0,2	0°	01		▲			▲	Δ		▲	▲	▲	Δ
R/L/S100.0520.E2	2,0	0,2	5°	01					Δ/Δ	Δ/Δ		▲/Δ	▲/▲	Δ/Δ	Δ/Δ
S100.0250.E2	2,5	0,2	0°	02					Δ	Δ		▲	▲	▲	▲
R/L/S100.0525.E2	2,5	0,2	5°	02					Δ/Δ	▲/Δ		▲/Δ	▲/▲	Δ/▲	Δ/Δ
S100.0300.E2	3,0	0,2	0°	03	▲	▲	▲	▲	▲	▲	▲	▲	▲	▲	▲
R/L/S100.0530.E2	3,0	0,2	5°	03		▲/Δ			Δ/▲	▲/Δ	▲/Δ	▲/▲	▲/▲	▲/▲	▲/Δ
S100.0400.E3	4,0	0,3	0°	04		▲			Δ	▲		▲	▲	▲	▲
R/L/S100.0540.E2	4,0	0,2	5°	04		Δ/Δ			Δ/Δ	Δ/Δ		▲/▲	▲/▲	Δ/Δ	Δ/Δ
S100.0500.E3	5,0	0,3	0°	05				Δ	Δ	▲		▲	▲	Δ	Δ
▲ ab Lager / on stock Δ 4 Wochen / 4 weeks x auf Anfrage / upon request					P	•	•	•	•	•	•	•	•	•	•
• empfohlen / recommended					M	-	-	o	-	-	-	-	•	o	-
o bedingt einsetzbar / alternative recommendation					K	-	-	-	-	-	-	-	•	•	-
- nicht geeignet / not suitable					N	-	-	-	-	-	-	-	•	•	-
unbeschichtete HM-Sorten / uncoated grades					S	-	-	o	-	-	-	-	•	o	-
beschichtete HM-Sorten / coated grades					H	-	-	-	-	-	-	-	-	-	-
bestückt/Cermet / brazed/Cermet															

Abmessungen in mm
Dimensions in mm
Ausführung R oder L angeben
State R or L version

HM-Sorten
Carbide grades

Einstechen und Abstechen

Grooving and Parting Off



A

Schneidplatte

Insert

S100

mit Spanformrinne
with chip former

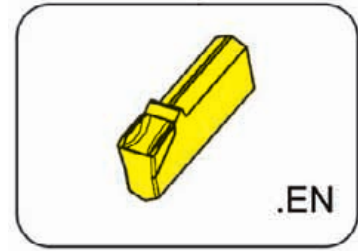

Stechbreite

Width of groove

2-16 mm

für Klemhalter
for Toolholder

Typ H100
Type

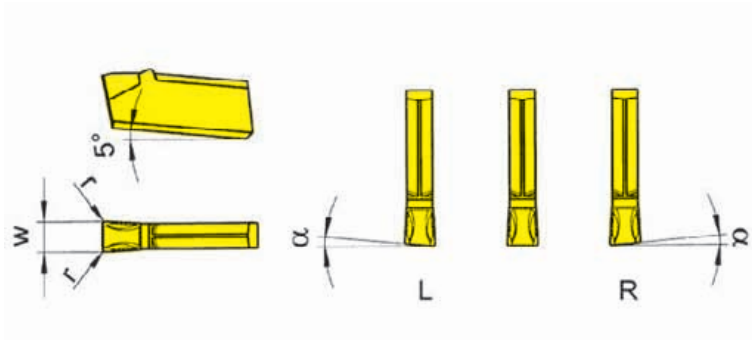

R = Rechtsausführung
R = right hand version

L = Linksausführung
L = left hand version

Bestellnummer Part number	w	r	α	Größe Size	ALX3	ALX5	AS62	AS63	AS66	AS6G	TF45	TH35
S100.0200.EN2	2,0	0,2	0°	01	▲	Δ				▲		Δ
S100.0220.EN2	2,2	0,2	0°	01	▲					▲		
S100.0250.EN2	2,5	0,2	0°	02	▲					▲		
S100.0300.EN2	3,0	0,2	0°	03	▲	Δ		▲	▲	▲	Δ	
RS100.0530.EN2	3,0	0,2	5°	03			▲		▲			
S100.0400.EN3	4,0	0,3	0°	04	▲			▲		▲		
R/LS100.0540.EN2	4,0	0,2	5°	04	▲/▲							
S100.0500.EN3	5,0	0,3	0°	05	▲							
S100.0600.EN6	6,0	0,8	0°	06						▲		
S100.0800.EN8	8,0	0,8	0°	08					▲	▲		
LS100.0480.EN8	8,0	0,8	4°	08					▲			
S100.1000.EN8	10,0	0,8	0°	10						▲		
S100.1200.EN8	12,0	0,8	0°	12						▲		
S100.1600.EN8	16,0	0,8	0°	16						▲		
▲ ab Lager / on stock Δ 4 Wochen / 4 weeks x auf Anfrage / upon request					P	•	•	•	•	•	•	•
● empfohlen / recommended					M	-	•	-	-	o	•	•
o bedingt einsetzbar / alternative recommendation					K	-	•	-	-	•	•	•
- nicht geeignet / not suitable					N	-	•	-	-	•	•	•
■ unbeschichtete HM-Sorten / uncoated grades					S	-	•	-	-	o	•	•
■ beschichtete HM-Sorten / coated grades					H	-	-	-	-	-	-	-
■ bestückt/Cermet / brazed/Cermet												

Abmessungen in mm
Dimensions in mm

Ausführung R oder L angeben
State R or L version

HM-Sorten
Carbide grades

Schneidplatte

Insert

S100

mit Spanformung
with chip forming

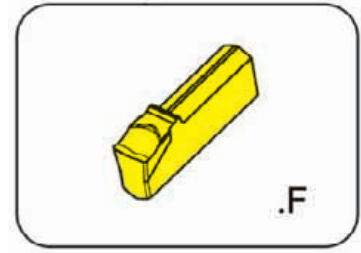

Stechbreite	Width of groove	2-5 mm
-------------	-----------------	--------

für Klemmhalter
for Toolholder

Typ H100
Type

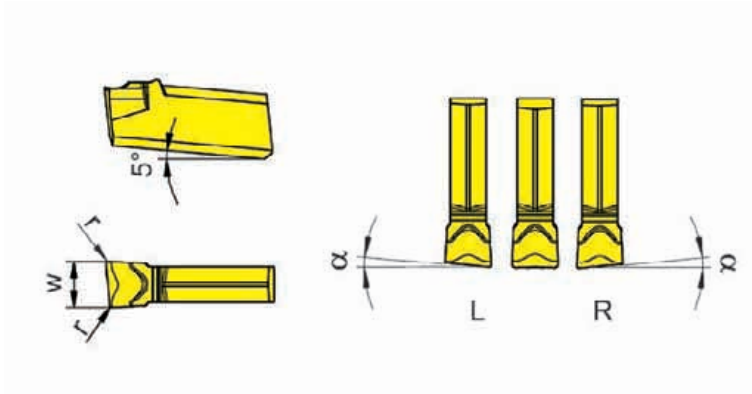

R = rechts wie gezeichnet
R = right hand version shown

L = links spiegelbildlich
L = left hand version

Bestellnummer Part number	w	r	α	Größe Size	ALX3	TC92	TC93	TF42	TF43	TF45	TF46	Ti22
S100.0200.F2	2,0	0,2	0°	01		▲	Δ		▲	▲	▲	▲
R/LS100.0520.F2	2,0	0,2	5°	01		Δ/Δ	Δ/Δ		Δ/Δ	▲/▲	▲/Δ	Δ/Δ
S100.0250.F2	2,5	0,2	0°	02		Δ	Δ		Δ	▲	Δ	▲
R/LS100.0525.F2	2,5	0,2	5°	02		Δ/Δ	Δ/Δ		Δ/Δ	▲/Δ	Δ/Δ	Δ/Δ
S100.0300.F2	3,0	0,2	0°	03		▲	▲	Δ	▲	▲	▲	▲
R/LS100.0530.F2	3,0	0,2	5°	03		Δ/Δ	Δ/▲		▲/▲	▲/▲	Δ/▲	Δ/Δ
S100.0400.F3	4,0	0,3	0°	04		Δ	Δ		▲	▲	▲	▲
R/LS100.0540.F2	4,0	0,2	5°	04		Δ/Δ	Δ/Δ		Δ/Δ	▲/▲	Δ/Δ	Δ/Δ
S100.0500.F3	5,0	0,3	0°	05	x	Δ	Δ		Δ	▲	Δ	▲
▲ ab Lager / on stock Δ 4 Wochen / 4 weeks x auf Anfrage / upon request					P	•	•	•	•	•	•	•
● empfohlen / recommended					M	-	-	-	-	•	o	-
o bedingt einsetzbar / alternative recommendation					K	-	-	-	-	•	•	-
- nicht geeignet / not suitable					N	-	-	-	-	•	•	-
■ unbeschichtete HM-Sorten / uncoated grades					S	-	-	-	-	•	o	-
■ beschichtete HM-Sorten / coated grades					H	-	-	-	-	-	-	-
■ bestückt/Cermet / brazed/Cermet												

Abmessungen in mm
Dimensions in mm
Ausführung R oder L angeben
State R or L version

HM-Sorten
Carbide grades

Einstechen und Abstechen

Grooving and Parting Off



Schneidplatte

Insert

S100

mit Spanformung
with chip forming

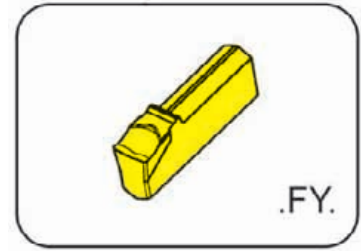

Stechbreite	Width of groove	2-4 mm
-------------	-----------------	--------

präzisionsgesintert
precision sintered

für Klemmhalter
for Toolholder

Typ H100
Type

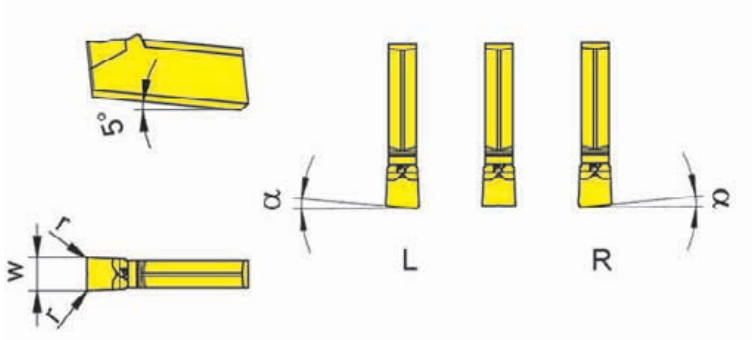

R = Rechtsausführung
R = right hand version

L = Linksausführung
L = left hand version

Bestellnummer Part number	w	r	α	Größe Size	AS45	HP65	PH35	TI25
S100.0200.FY2	2,0	0,2	0°	01	Δ	▲	▲	▲
R/LS100.1520.FY0	2,0	-	15°	01	▲/▲			
S100.0220.FY2	2,2	0,2	0°	01				▲
S100.0250.FY2	2,5	0,2	0°	02	Δ	▲		▲
S100.0300.FY2	3,0	0,2	0°	03	Δ	▲	▲	▲
R/LS100.1530.FY0	3,0	-	15°	03	▲/▲			
S100.0400.FY3	4,0	0,3	0°	04		▲		▲

▲ ab Lager / on stock Δ 4 Wochen / 4 weeks x auf Anfrage / upon request

● empfohlen / recommended

o bedingt einsetzbar / alternative recommendation

- nicht geeignet / not suitable

□ unbeschichtete HM-Sorten / uncoated grades

■ beschichtete HM-Sorten / coated grades

■ bestückt/Cermet / brazed/Cermet

Abmessungen in mm

Dimensions in mm

Schneidplatten sind in **rechten und linken** Klemmhaltern verwendbar.

Indexable inserts can be used in **right and left** hand toolholders.

P	●	●	○	●
M	●	●	○	●
K	●	●	●	●
N	○	○	-	●
S	●	●	-	●
H	-	-	-	-

HM-Sorten
Carbide grades

Schneidplatte

Insert

S100

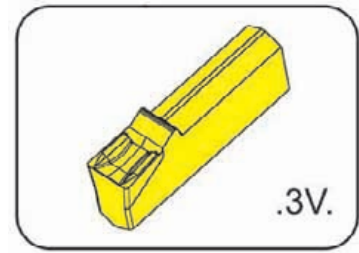
mit Spanformung
with chip forming

Stechbreite

Width of groove

2-4 mm

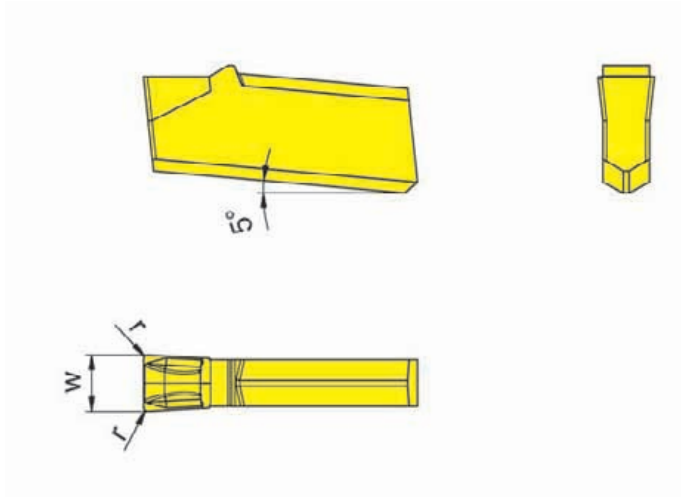
für Klemmhalter
for ToolholderTyp H100
Type

Bestellnummer Part number	w	r	Größe Size	AS45	HP35	HP65	PH35	
S100.0200.3V2	2,0	0,2	01	▲	△	▲	▲	
S100.0250.3V2	2,5	0,2	02	▲		▲		
S100.0300.3V2	3,0	0,2	03	▲		▲	▲	
S100.0400.3V3	4,0	0,3	04	▲		▲		
▲ ab Lager / on stock △ 4 Wochen / 4 weeks x auf Anfrage / upon request ● empfohlen / recommended ○ bedingt einsetzbar / alternative recommendation - nicht geeignet / not suitable □ unbeschichtete HM-Sorten / uncoated grades ■ beschichtete HM-Sorten / coated grades ■ bestückt/Cermet / brazed/Cermet				P	●	○	●	○
				M	●	●	●	○
				K	●	○	●	●
				N	○	-	○	-
				S	●	○	●	-
				H	-	-	-	-

Abmessungen in mm
Dimensions in mmHM-Sorten
Carbide grades

Einstechen und Abstechen

Grooving and Parting Off



A

Schneidplatte

Insert

S100

mit Spanformung
with chip forming

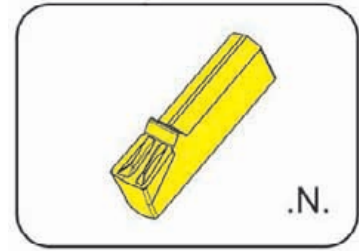

Stechbreite	Width of groove	3-4 mm
-------------	-----------------	--------

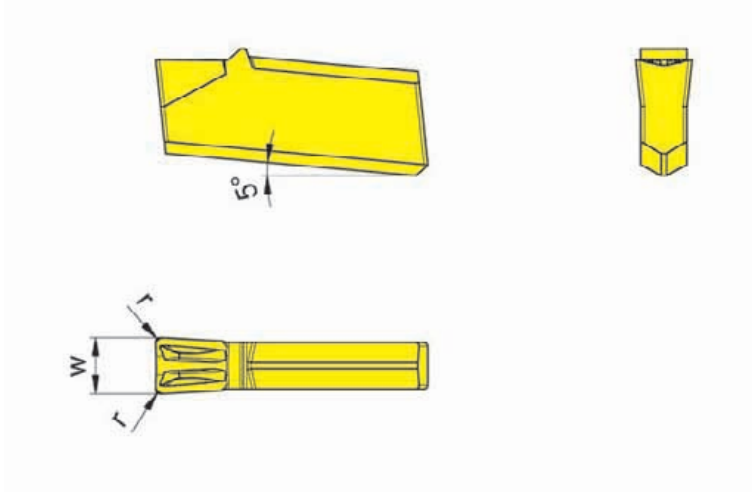

für Klemmhalter
for Toolholder

Typ H100
Type

Bestellnummer Part number	w	r	Größe Size	AS45	HP65
S100.0300.N2	3	0,2	03	▲	▲
S100.0400.N3	4	0,3	04	▲	▲

▲ ab Lager / on stock Δ 4 Wochen / 4 weeks x auf Anfrage / upon request

● empfohlen / recommended

o bedingt einsetzbar / alternative recommendation

- nicht geeignet / not suitable

■ unbeschichtete HM-Sorten / uncoated grades

■ beschichtete HM-Sorten / coated grades

■ bestückt/Cermet / brazed/Cermet

Abmessungen in mm

Dimensions in mm

	AS45	HP65
P	●	●
M	●	●
K	●	●
N	o	o
S	●	●
H	-	-

HM-Sorten
Carbide grades

Klemmhalter **H100**

Toolholder

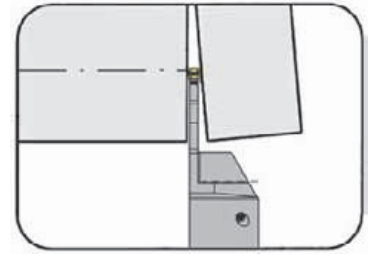

Stechtiefe bis Stechbreite	Depth of groove up to Width of groove	41,0 mm 3,0 - 4,0 mm
-------------------------------	--	-------------------------

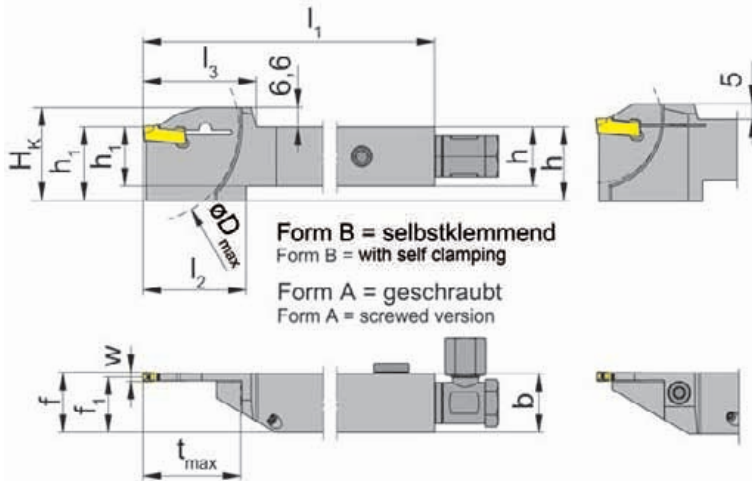

für Schneidplatte
for insert

Typ S100
Type

Kühlmittelzufuhr durch die
Schneidplatte
Coolant supply through insert

L = links wie gezeichnet
L = left hand version shown

R = rechts spiegelbildlich
R = right hand version

Bestellnummer Part number	h	b	l ₁	l ₂	l ₃	h ₁	f ₁	f	t _{max}	D _{max}	H _k	Form Form	Größe Size
R/LH100.1616.1.23.IK	16	16	125	35	33,5	27	14,85	f ₁ +w/2	21,5	42	32,0	A	03
R/LH100.2020.1.13.IK	20	20	125	30	28,5	27	18,85	f ₁ +w/2	16,0	42	32,0	A	03
R/LH100.2020.1.23.IK	20	20	125	35	33,5	27	18,85	f ₁ +w/2	21,5	42	32,0	A	03
R/LH100.2020.1.33.IK	20	20	125	35	38,5	27	18,85	f ₁ +w/2	33,0	65	33,6	B	03
R/LH100.2525.1.33.IK	25	25	150	35	38,5	32	23,85	f ₁ +w/2	33,0	65	38,6	B	03
R/LH100.2020.1.34.IK	20	20	125	35	38,5	27	18,45	f ₁ +w/2	33,0	65	33,6	B	04
R/LH100.2525.1.34.IK	25	25	150	40	46,5	32	23,45	f ₁ +w/2	41,0	81	38,6	B	04

Ausführung R oder L angeben
State R or L version

w siehe Schneidplatten
w see inserts

Abmessungen in mm
Dimensions in mm

Weitere Abmessungen auf Anfrage
Further sizes upon request

Bestellhinweis:

Der Schlüssel **P39L** gehört nicht zum Lieferumfang des Schneidenträgers. Bitte separat bestellen!

Ordering note:

Wrench **P39L** ist not combined with blade - separate order required!

Das Anzugsdrehmoment der Schrauben finden Sie in den Technischen Hinweisen.

For torque specification of the screw, please see Technical Instructions.

Ersatzteile

Spare Parts

Klemmhalter Toolholder	Spannschraube Screw	Dichtstopfen Sealing plug	Kühlmittelanschluss Coolant supply	TORX PLUS®-Schlüssel TORX PLUS® Wrench	Spannschlüssel Wrench
R/LH100...13/23.IK	5.17T20P	004.00.26	004.00.16	T20PQ	
R/LH100....		004.00.26	004.00.16		P39L

Einstechen und Abstechen

Grooving and Parting Off



A

Klemmhalter

Toolholder

H100

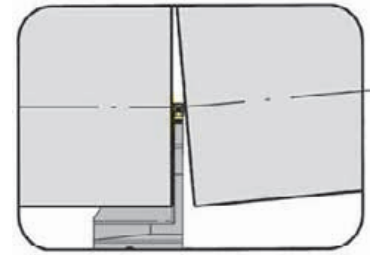

Stechtiefe bis	Depth of groove up to	33 mm
Stechbreite	Width of groove	3,0 mm

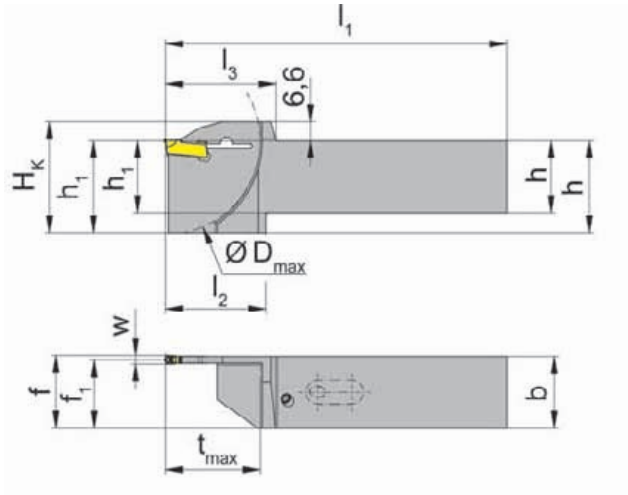

für Schneidplatte
for insert

Typ S100
Type

mit integrierter innerer
Kühlmittelzufuhr
with integrated through
coolant supply

L = links wie gezeichnet
L = left hand version shown

R = rechts spiegelbildlich
R = right hand version

Bestellnummer Part number	h	b	l ₁	l ₂	l ₃	h ₁	f ₁	f	t _{max}	D _{max}	H _k	Größe Size
R/LH100.2020.3.33.IK	20	20	104	35	38,5	27	18,85	f ₁ +w/2	33	65	33,6	03
R/LH100.2525.3.33.IK	25	25	119	35	38,5	32	23,85	f ₁ +w/2	33	65	38,6	03

Ausführung R oder L angeben
State R or L version

w siehe Schneidplatten
w see inserts

Abmessungen in mm
Dimensions in mm

Weitere Abmessungen auf Anfrage
Further sizes upon request

Bestellhinweis:

Der Schlüssel **P39L** gehört nicht zum Lieferumfang des Schneidenträgers. Bitte separat bestellen!

Ordering note:

Wrench **P39L** ist not combined with blade - separate order required!

A Einstechen und Abstechen

Grooving and Parting Off



Schneidplatte

Insert

S100

mit Spanformrinne
with chip former

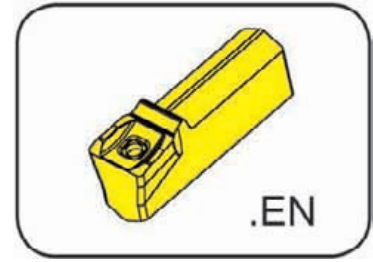

Stechbreite	Width of groove	3-4 mm
-------------	-----------------	--------

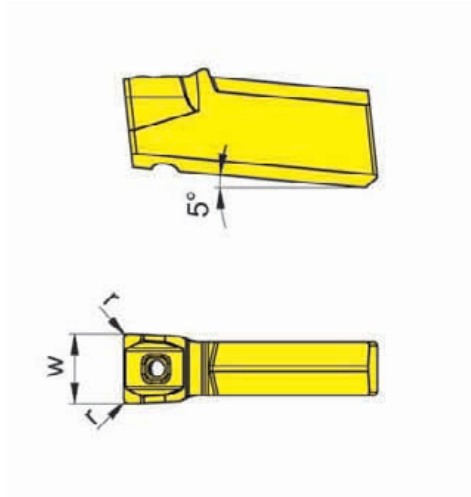

für Klemmhalter
for Toolholder

Typ H100...13/23/33/34IK
Type

Kühlmittelzufuhr durch die
Schneidplatte
Coolant supply through insert

Bestellnummer Part number	w	r	Größe Size	AS45	HP65
S100.0300.EN2.IK	3	0,2	03	▲	▲
S100.0400.EN3.IK	4	0,3	04	▲	▲
				P	•
				M	•
				K	•
				N	o
				S	•
				H	-

- ▲ ab Lager / on stock Δ 4 Wochen / 4 weeks x auf Anfrage / upon request
- empfohlen / recommended
- o bedingt einsetzbar / alternative recommendation
- nicht geeignet / not suitable
- unbeschichtete HM-Sorten / uncoated grades
- beschichtete HM-Sorten / coated grades
- bestückt/Cermet / brazed/Cermet

Abmessungen in mm
Dimensions in mm

Schneidplatten sind in **rechten und linken** Klemmhaltern verwendbar.
Indexable inserts can be used in **right and left** hand toolholders.

HM-Sorten
Carbide grades

Einstecken und Abstecken

Grooving and Parting Off



A

Schneidplatte

Insert

S100

mit Spanformrinne
with chip former

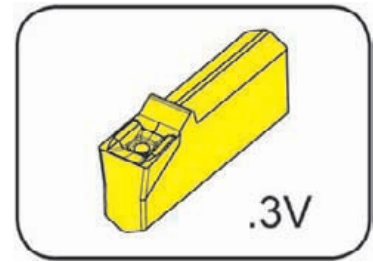

Stechbreite	Width of groove	2,5-3 mm
-------------	-----------------	----------

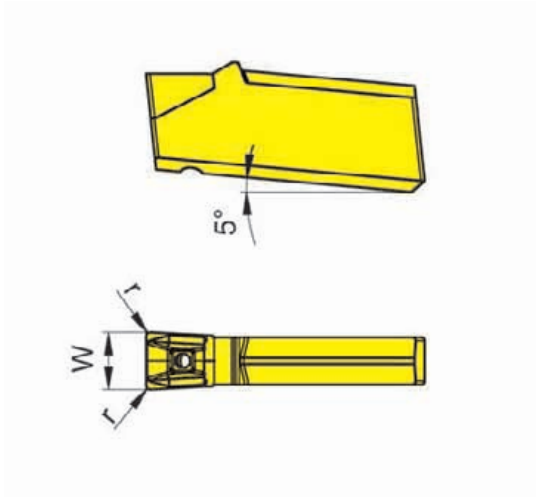

für Klemmhalter
for Toolholder

Typ H100...13/23/33/34IK
Type

Kühlmittelzufuhr durch die
Schneidplatte
Coolant supply through insert

Bestellnummer Part number	w	r	Größe Size	HP65
S100.0250.3V2.IK	2,5	0,2	02	▲
S100.0300.3V2.IK	3,0	0,2	03	▲

- ▲ ab Lager / on stock Δ 4 Wochen / 4 weeks x auf Anfrage / upon request
- empfohlen / recommended
- o bedingt einsetzbar / alternative recommendation
- nicht geeignet / not suitable
- unbeschichtete HM-Sorten / uncoated grades
- beschichtete HM-Sorten / coated grades
- bestückt/Cermet / brazed/Cermet

Abmessungen in mm
Dimensions in mm

Schneidplatten sind in **rechten und linken** Klemmhaltern verwendbar.
Indexable inserts can be used in **right and left** hand toolholders.

HP65
HM-Sorten
Carbide grades

P	●
M	●
K	●
N	○
S	●
H	-

Klemmhalter

Toolholder

H101

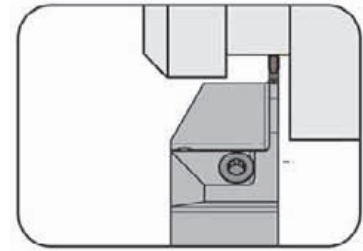
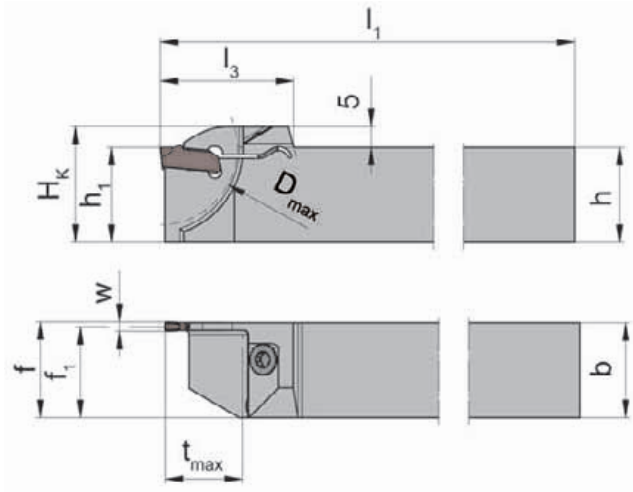
mit Schraubklemmung
with screwed clampingStechtiefe bis
StechbreiteDepth of groove up to
Width of groove13 mm
1,6 mmfür Schneidplatte
for InsertTyp S101
Type

Bestellnummer Part number	h	b	l_1	l_3	h_1	f_1	f	t_{max}	H_K	D_{max}	Größe Size
R/LH101.1010.1.16	10	10	125	22,5	10	9,35	$f_1+w/2$	13	13,5	26	16
R/LH101.1212.1.16	12	12	125	22,5	12	11,35	$f_1+w/2$	13	15,5	26	16
R/LH101.1616.1.16	16	16	125	22,5	16	15,35	$f_1+w/2$	13	19,5	26	16

Ausführung R oder L angeben

State R or L version

w siehe Schneidplatten

w see inserts

Abmessungen in mm

Dimensions in mm

Weitere Abmessungen auf Anfrage

Further sizes upon request

Das Anzugsdrehmoment der Schrauben finden Sie in den Technischen Hinweisen.

For torque specification of the screw, please see Technical Instructions.

Ersatzteile

Spare Parts

Klemmhalter Toolholder	Spannschraube Screw	TORX PLUS®-Schlüssel TORX PLUS® Wrench
R/LH101...	3.5.12T10EP	T10PL

Einstechen und Abstechen

Grooving and Parting Off



A

Schneidplatte

Insert

S101

mit Spanformung
with chip forming

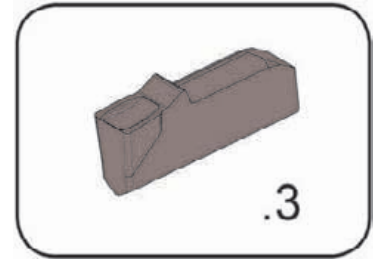

Stechbreite	Width of groove	1,6 mm
-------------	-----------------	--------

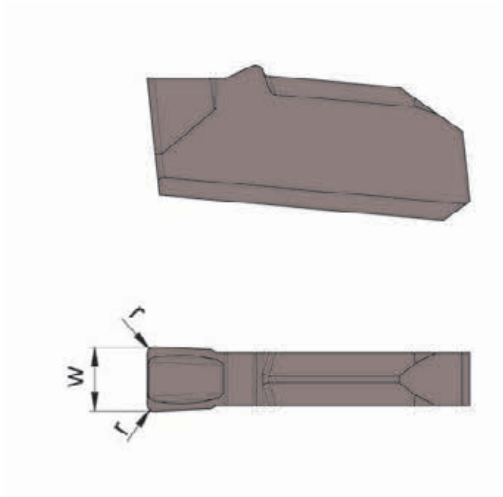

für Klemmhalter
for Toolholder

Typ H101
Type

Bestellnummer Part number	w	r	Größe Size	AS45
S101.0160.315	1,6	0,15	16	▲
▲ ab Lager / on stock				P ●
● empfohlen / recommended				M ●
o bedingt einsetzbar / alternative recommendation				K ●
- nicht geeignet / not suitable				N ○
■ unbeschichtete HM-Sorten / uncoated grades				S ●
■ beschichtete HM-Sorten / coated grades				H -
■ bestückt/Cermet / brazed/Cermet				

Abmessungen in mm

Dimensions in mm





**Klemmhalter
mit Schneidplatten**

Formbreite 10 - 45 mm

**Toolholder
with Inserts**

Width of profile 10 - 45 mm

Formeinstechen (außen)

Profiling (external)

B

Klemmhalter
Toolholder
H117

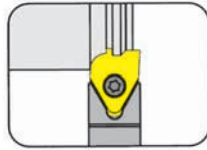

Seite/Page
B3-B4, B6,

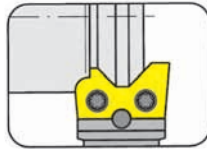

Seite/Page
B8

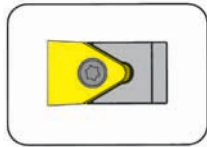

Seite/Page
B10

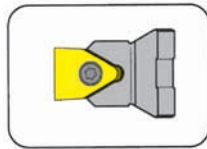

Seite/Page
B11

Schneidplatte
Insert
S117

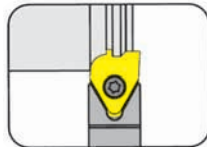

Seite/Page
B5, B7

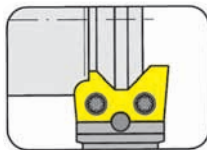

Seite/Page
B9

Formeinstechen (außen)

Profiling (external)



Klemmhalter

Toolholder

H117

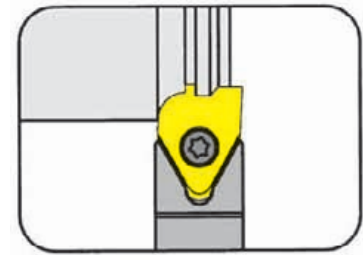

Formtiefe bis	Depth of form up to	4,5 mm
Formbreite bis	Width of form up to	12,0 mm

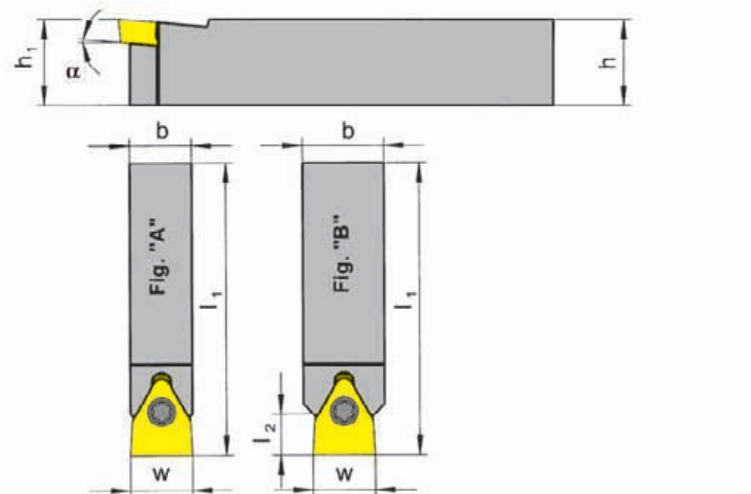

für Schneidplatte
for Insert

Typ S117
Type

Bestellnummer Part number	h	b	l ₁	h ₁	α	Figur	l ₂	w	Schneidplatte Insert
H117.1010.10	10	10	100	10	5°	A	-	10	S117.0010.00
H117.1212.10	12	12	125	12	5°	B	9	10	S117.0010.00
H117.1616.10	16	16	125	16	5°	B	9	10	S117.0010.00
H117.1212.12	12	12	125	12	5°	A	-	12	S117.0012.00
H117.1414.12	14	14	125	14	5°	B	8	12	S117.0012.00
H117.1612.12	16	12	125	16	5°	A	-	12	S117.0012.00
H117.1616.12	16	16	125	16	5°	B	8	12	S117.0012.00
H117.2020.12	20	20	150	20	5°	B	8	12	S117.0012.00

Weitere Einlegewinkel auf Anfrage
Further angles upon request

Abmessungen in mm
Dimensions in mm

Das Anzugsdrehmoment der Schrauben finden Sie in den Technischen Hinweisen.
For torque specification of the screw, please see Technical Instructions.

Ersatzteile

Spare Parts

Klemmhalter Toolholder	Spannschraube Screw	TORX PLUS®-Schlüssel TORX PLUS® Wrench
H117.1010.10	030.400P.0227	T15PQ
H117...	4.09T15P	T15PQ

Formeinstechen (außen)

Profiling (external)



B

Klemmhalter

Toolholder

H117

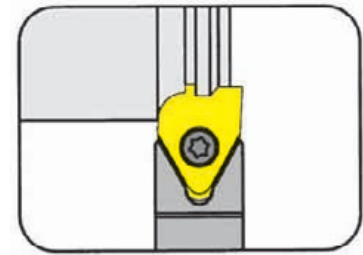

Formtiefe bis
Formbreite bis

Depth of form up to
Width of form up to

10 mm
26 mm

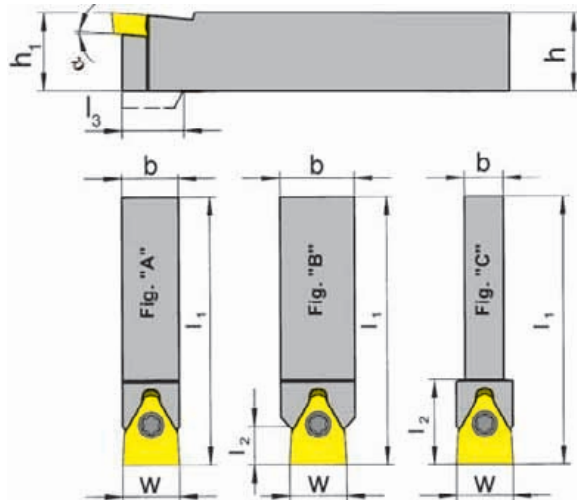

für Schneidplatte
for Insert

Typ S117
Type

Bestellnummer Part number	h	b	l ₁	h ₁	l ₃	α	Figur	l ₂	w	Schneidplatte Insert
H117.1414.16	14	14	125	14	18	5°	C	22,0	16	S117.0014/16.00
H117.1616.16	16	16	125	16	-	5°	A / B	11,0	16	S117.0014/16.00
H117.2020.16	20	20	150	20	-	5°	B	11,0	16	S117.0014/16.00
H117.2525.16	25	25	150	25	-	5°	B	8,5	16	S117.0014/16.00
H117.1616.20	16	16	125	16	23	5°	C	30,0	20	S117.0018/20.00
H117.2020.20	20	20	150	20	-	5°	A / B	15,0	20	S117.0018/20.00
H117.2525.20	25	25	150	25	-	5°	B	15,0	20	S117.0018/20.00
H117.2020.26	20	20	150	20	-	5°	C	30,0	26	S117.0026.00
H117.2525.26	25	25	150	25	-	5°	A	-	26	S117.0026.00

Weitere Einlegewinkel auf Anfrage
Further angles upon request

Abmessungen in mm
Dimensions in mm

Das Anzugsdrehmoment der Schrauben finden Sie in den Technischen Hinweisen.
For torque specification of the screw, please see Technical Instructions.

Ersatzteile

Spare Parts

Klemmhalter Toolholder	Spannschraube Screw	TORX PLUS®-Schlüssel TORX PLUS® Wrench
H117...16	5.12T20P	T20PQ
H117...	6.17 T20P	T20PQ

Formeinstechen (außen)

Profiling (external)



Schneidplatte

Insert

S117

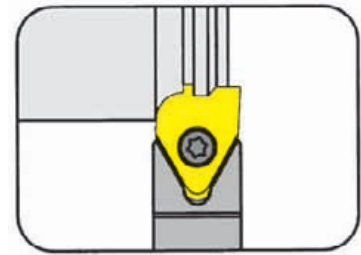

Formtiefe bis Formbreite bis	Depth of form up to Width of form up to	10 mm 26 mm
---------------------------------	--	----------------

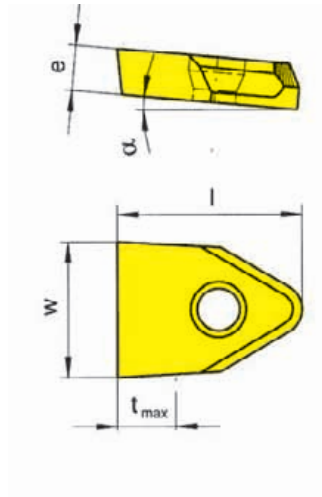

für Klemmhalter
for Toolholder

Typ H117
Type

Bestellnummer Part number	w	e	t _{max}	l	α	Klemmhalter Toolholder	MG12	H54
S117.0010.00	10	3,0	3,5	16	5°	H117...10	▲	
S117.0012.00	12	4,5	4,5	17	5°	H117...12	▲	Δ
S117.0014.00	14	6,0	6,0	21	5°	H117...16	▲	
S117.0016.00	16	6,0	6,0	21	5°	H117...16	▲	
S117.0018.00	18	7,0	9,0	29	5°	H117...20	▲	
S117.0020.00	20	7,0	9,0	29	5°	H117...20	▲	
S117.0026.00	26	7,0	10,0	32	5°	H117...26	▲	

▲ ab Lager / on stock Δ 4 Wochen / 4 weeks x auf Anfrage / upon request

● empfohlen / recommended

o bedingt einsetzbar / alternative recommendation

- nicht geeignet / not suitable

■ unbeschichtete HM-Sorten / uncoated grades

■ beschichtete HM-Sorten / coated grades

■ bestückt/Cermet / brazed/Cermet

P	○	●
M	●	●
K	●	-
N	●	-
S	●	-
H	-	-

Abmessungen in mm
Dimensions in mm



Profilierte Schneidplatten auf Anfrage
Profile inserts upon request.

Formeinstechen (außen)

Profiling (external)



B

Klemmhalter

Toolholder

H117

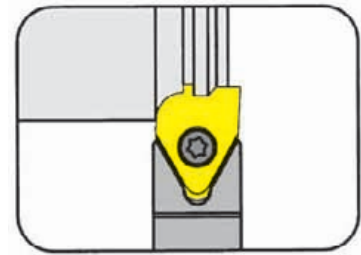

Formtiefe bis
Formbreite bis

Depth of form up to
Width of form up to

13 mm
26 mm

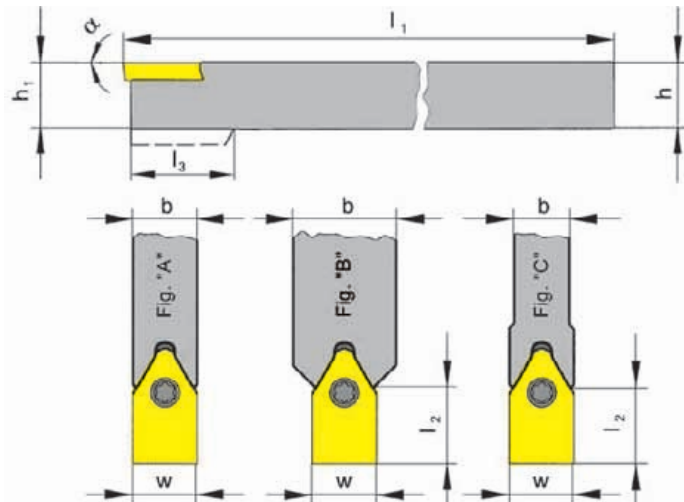

für Schneidplatte
for Insert

Typ S117
Type

Bestellnummer Part number	h	b	l ₁	h ₁	l ₃	α	Figur	l ₂	w	Schneidplatte Insert
H117.1010.02.10	10	10	100	10	-	0°	A	-	10	S117.0010.02.00
H117.1212.02.10	12	12	125	12	-	0°	B	12	10	S117.0010.02.00
H117.1616.02.10	16	16	125	16	-	0°	B	12	10	S117.0010.02.00
H117.1212.02.12	12	12	125	12	-	0°	A	-	12	S117.0012.02.00
H117.1616.02.12	16	16	125	16	-	0°	B	11	12	S117.0012.02.00
H117.2020.02.12	20	20	150	20	-	0°	B	11	12	S117.0012.02.00
H117.1616.02.16	16	16	125	16	-	0°	A	-	16	S117.0016.02.00
H117.2020.02.16	20	20	150	20	-	0°	B	14	16	S117.0016.02.00
H117.1616.02.20	16	16	125	16	26	0°	C	33	20	S117.0020.02.00
H117.2020.02.20	20	20	150	20	-	0°	A	-	20	S117.0020.02.00
H117.2525.02.20	25	25	150	25	-	0°	B	19	20	S117.0020.02.00
H117.2020.02.26	20	20	150	20	-	0°	C	33	26	S117.0026.02.00
H117.2525.02.26	25	25	150	25	-	0°	A	-	26	S117.0026.02.00

Weitere Abmessungen auf Anfrage
Further sizes upon request

w siehe Schneidplatten

Abmessungen in mm
Dimensions in mm

Das Anzugsdrehmoment der Schrauben finden Sie in den Technischen Hinweisen.
For torque specification of the screw, please see Technical Instructions.

Ersatzteile

Spare Parts

Klemmhalter Toolholder	Spannschraube Screw	TORX PLUS®-Schlüssel TORX PLUS® Wrench
H117...10/12	4.09T15P	T15PQ
H117...16	5.12T20P	T20PQ
H117...20/26	6.17 T20P	T20PQ

Formeinstechen (außen)

Profiling (external)



Schneidplatte

Insert

S117

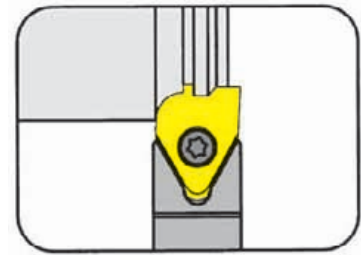

Formtiefe bis	Depth of form up to	13 mm
Formbreite bis	Width of form up to	26 mm

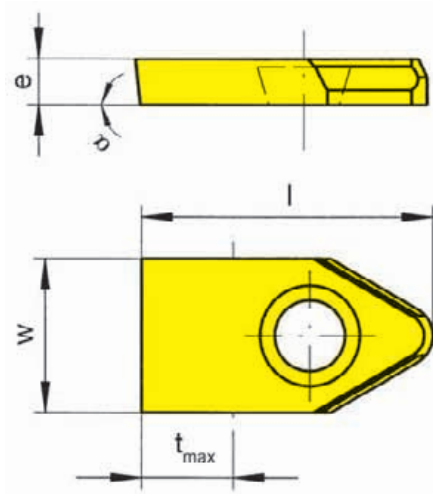

für Klemmhalter
for Toolholder

Typ H117
Type

Bestellnummer Part number	w	e	t _{max}	l	α	Klemmhalter Toolholder	MG12
S117.0010.02.00	10	3,0	6,5	19	0°	H117...02.10	▲
S117.0012.02.00	12	4,5	7,5	20	0°	H117...02.12	▲
S117.0016.02.00	16	6,0	9,0	24	0°	H117...02.16	▲
S117.0020.02.00	20	7,0	12,0	32	0°	H117...02.20	▲
S117.0026.02.00	26	7,0	13,0	35	0°	H117...02.26	▲

▲ ab Lager / on stock Δ 4 Wochen / 4 weeks x auf Anfrage / upon request

● empfohlen / recommended

o bedingt einsetzbar / alternative recommendation

- nicht geeignet / not suitable

■ unbeschichtete HM-Sorten / uncoated grades

■ beschichtete HM-Sorten / coated grades

■ bestückt/Cermet / brazed/Cermet

Weitere Abmessungen auf Anfrage

Further sizes upon request

P	○
M	●
K	●
N	●
S	●
H	-

Abmessungen in mm
Dimensions in mm



Profilierte Schneidplatten auf Anfrage
Profile inserts upon request.

Formeinstechen (außen)

Profiling (external)



B

Klemmhalter

Toolholder

H117

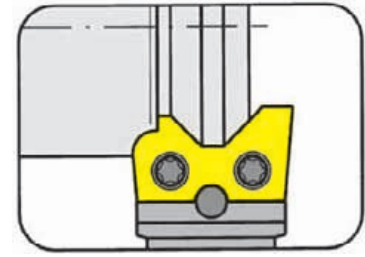

Formtiefe bis
Formbreite bis

Depth of form up to
Width of form up to

6,5 mm
45,0 mm

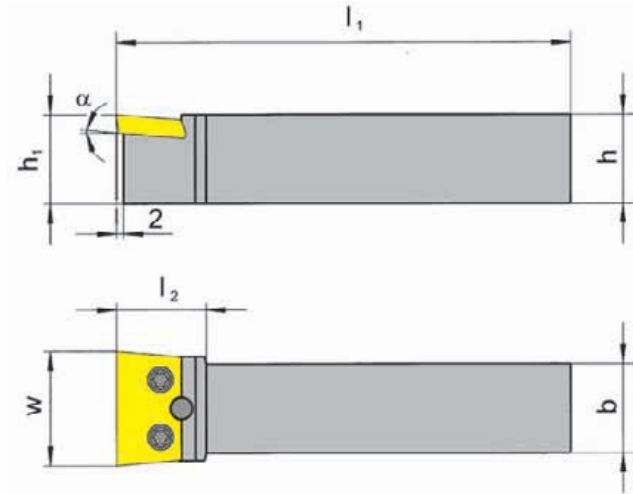

für Schneidplatte
for Insert

Typ S117
Type

Bestellnummer Part number	h	b	l_1	h_1	α	l_2	w	Schneidplatte Insert
H117.2020.32	20	20	150	20	5°	25	32	S117.0032.00
H117.2525.32	25	25	150	25	5°	25	32	S117.0032.00
H117.2525.45	25	25	150	25	5°	27	45	S117.0045.00
H117.3232.45	32	32	170	32	5°	27	45	S117.0045.00

Weitere Einlegewinkel auf Anfrage
Further angles upon request

w siehe Schneidplatten

Abmessungen in mm
Dimensions in mm

Das Anzugsdrehmoment der Schrauben finden Sie in den Technischen Hinweisen.
For torque specification of the screw, please see Technical Instructions.

Ersatzteile

Spare Parts

Klemmhalter Toolholder	Spannschraube Screw	TORX PLUS®-Schlüssel TORX PLUS® Wrench
H117...	5.12T20P	T20PQ

Formeinstechen (außen)

Profiling (external)



Schneidplatte

Insert

S117

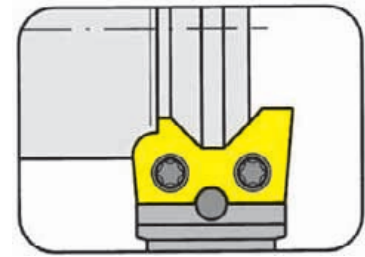

Formtiefe bis
Formbreite bis

Depth of form up to
Width of form up to

6,5 mm
45 mm

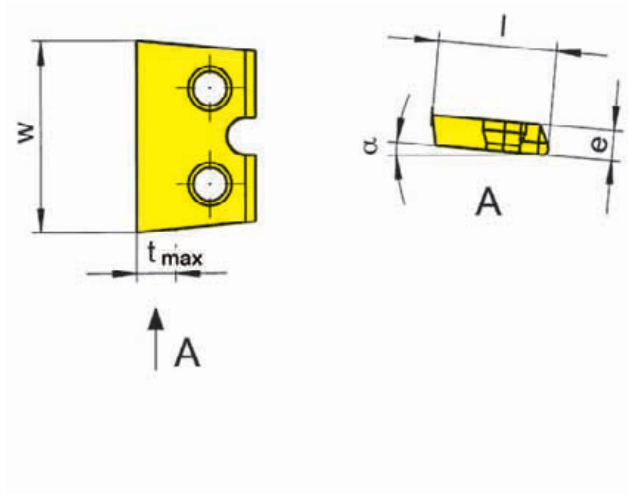

für Klemmhalter
for Toolholder

Typ H117
Type

Bestellnummer Part number	w	e	t _{max}	l	α	Klemmhalter Toolholder	MG12
S117.0032.00	32	5	6,5	19,7	5°	H117...32	▲
S117.0045.00	45	5	6,5	19,7	5°	H117...45	▲

▲ ab Lager / on stock Δ 4 Wochen / 4 weeks x auf Anfrage / upon request

● empfohlen / recommended

o bedingt einsetzbar / alternative recommendation

- nicht geeignet / not suitable

■ unbeschichtete HM-Sorten / uncoated grades

■ beschichtete HM-Sorten / coated grades

■ bestückt/Cermet / brazed/Cermet

P	○
M	●
K	●
N	●
S	●
H	-

Weitere Abmessungen auf Anfrage

Further sizes upon request

Abmessungen in mm

Dimensions in mm



Profilierte Schneidplatten auf Anfrage
Profile inserts upon request.

B

Formeinstechen (außen)

Profiling (external)



B

Klemmhalter

Toolholder

H117

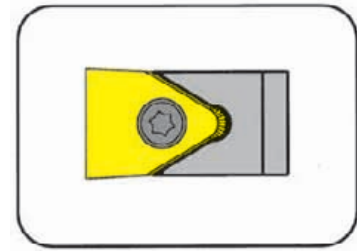

Formtiefe bis
Formbreite bis

Depth of form up to
Width of form up to

6,5 mm
45,0 mm

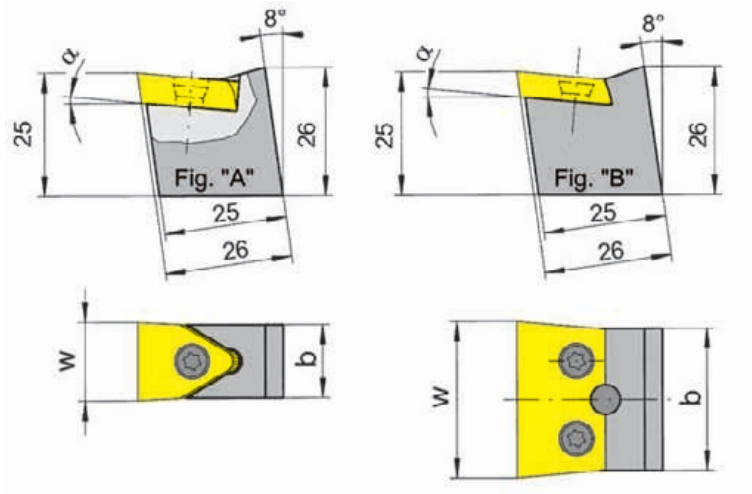

für Schneidplatte
for Insert

Typ S117
Type

mit PWP-System
with PWP-System

Bestellnummer Part number	b	α	Figur	w	Schneidplatte Insert
H117.PWP.10	10	5°	A	10	S117.0010.00
H117.PWP.12	12	5°	A	12	S117.0012.00
H117.PWP.16	16	5°	A	16	S117.0014/16.00
H117.PWP.32	28	5°	B	32	S117.0032.00
H117.PWP.45	42	5°	B	45	S117.0045.00

Weitere Einlegewinkel auf Anfrage
Further angles upon request

w siehe Schneidplatten

Abmessungen in mm
Dimensions in mm

Das Anzugsdrehmoment der Schrauben finden Sie in den Technischen Hinweisen.
For torque specification of the screw, please see Technical Instructions.

Ersatzteile

Spare Parts

Klemmhalter Toolholder	Spannschraube Screw	TORX PLUS®-Schlüssel TORX PLUS® Wrench
H117.PWP.10	4.09T15P	T15PL
H117.PWP.12	4.09T15P	T15PQ
H117.PWP...	5.12T20P	T20PQ

Formeinstechen (außen)

Profiling (external)



Klemmhalter

Toolholder

H117

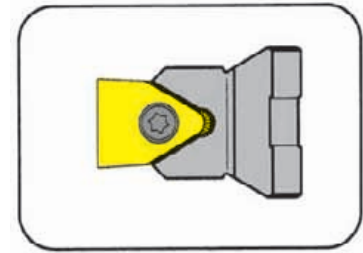

Formtiefe bis	Depth of form up to	10 mm
Formbreite bis	Width of form up to	45 mm

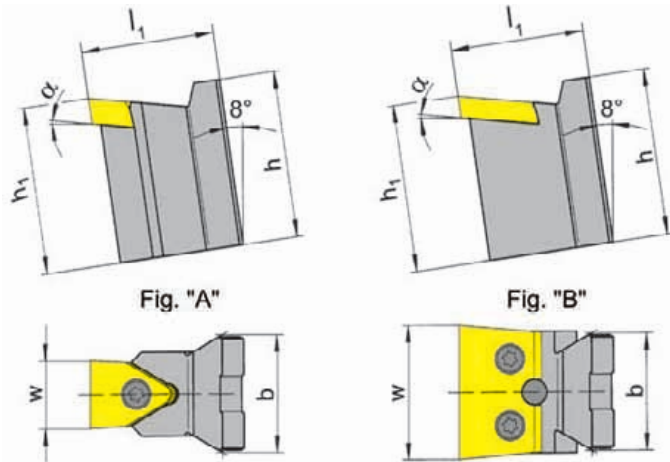

für Schneidplatte
for Insert

Typ S117
Type

mit AWN-System
with AWN-System

Bestellnummer Part number	h	b	l ₁	h ₁	t _{max}	α	Figur	w	Schneidplatte Insert
H117.AW20.10	36	20	32	40	3,5	5°	A	10	S117.0010.00
H117.AW28.10	36	28	32	40	3,5	5°	A	10	S117.0010.00
H117.AW20.12	36	20	32	40	4,5	5°	A	12	S117.0012.00
H117.AW28.12	36	28	32	40	4,5	5°	A	12	S117.0012.00
H117.AW20.16	36	20	32	40	6,5	5°	A	16	S117.0014/16.00
H117.AW28.16	36	28	32	40	6,5	5°	A	16	S117.0014/16.00
H117.AW28.20	36	28	32	40	9,0	5°	A	20	S117.0018/20.00
H117.AW28.26	36	28	35	40	10,0	5°	A	26	S117.0026.00
H117.AW28.32	36	28	32	40	6,5	5°	B	32	S117.0032.00
H117.AW40.45	50	40	32	50	6,5	5°	B	45	S117.0045.00

Weitere Einlegewinkel auf Anfrage
Further angles upon request

w siehe Schneidplatten

Abmessungen in mm
Dimensions in mm

Das Anzugsdrehmoment der Schrauben finden Sie in den Technischen Hinweisen.
For torque specification of the screw, please see Technical Instructions.

Ersatzteile

Spare Parts

Klemmhalter Toolholder	Spannschraube Screw	TORX PLUS®-Schlüssel TORX PLUS® Wrench
H117.AW2...10/12	4.09T15P	T15PQ
H117.AW...16/32/45	5.12T20P	T20PQ
H117.AW28.20/26	6.17T20P	T20PQ



119/123/223

C



**Klemmhalter mit
Schneidplatten**

Stechbreite 1,1 - 3,0 mm

**Toolholder with
Inserts**

Width of groove 1,1 - 3,0 mm

Einstecken und Längsdrehen

Grooving and Side Turning



Klemmhalter
Toolholder
H223/B119/B223

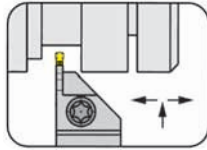

Seite/Page
C3



Seite/Page
C4

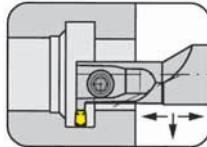

Seite/Page
C6-C8

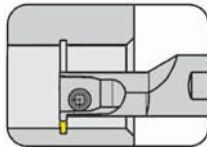

Seite/Page
C9

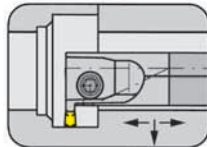

Seite/Page
C10

Kurzklemmhalter
Cartridge
E223

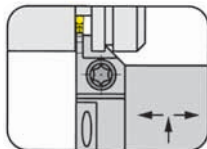

Seite/Page
C5

Grundhalter
Basic toolholder
B223

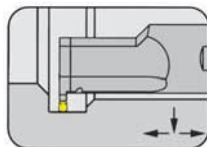

Seite/Page
C11

Kassette
Cassette
BK223

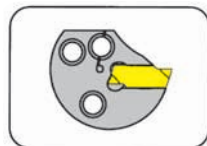

Seite/Page
C12

Schneidplatte
Insert
S119/S223/S123

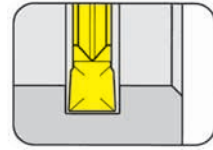

Seite/Page
C13, C16

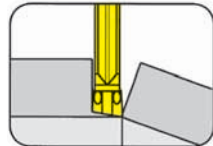

Seite/Page
C14-C15, C20-C21

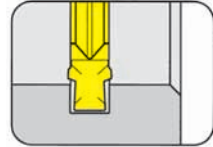

Seite/Page
C17

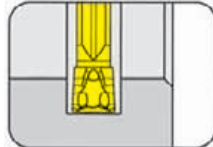

Seite/Page
C18

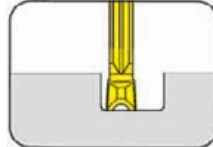

Seite/Page
C19

Einstecken und Längsdrehen (außen)

Grooving and Side Turning (external)



Klemmhalter

Toolholder

H223

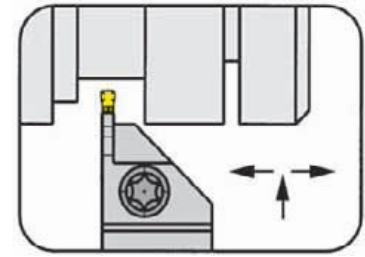

Stechtiefe bis Spannbereich	Depth of groove up to Clamping range	10 mm 2,0 - 3,0 mm
--------------------------------	---	-----------------------

für Schneidplatte
for insert

Typ S223
Type S123

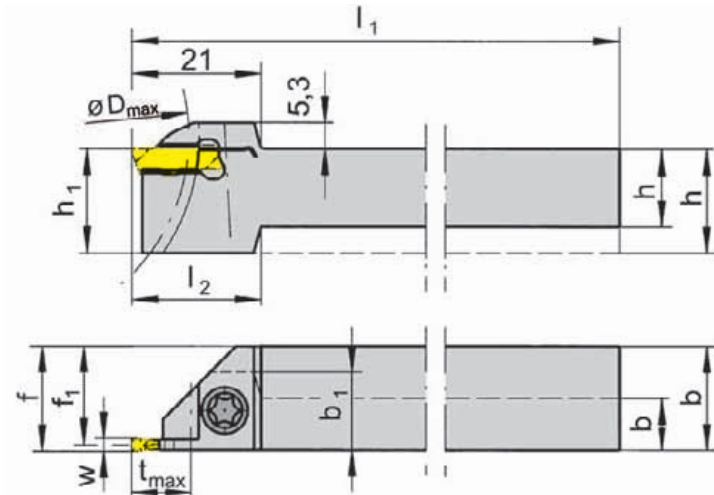

R = rechts wie gezeichnet
R = right hand version shown

L = links spiegelbildlich
L = left hand version

Bestellnummer Part number	h	b	l ₁	l ₂	h ₁	f ₁	f	t _{max}	D _{max}	b ₁	Größe Size	Spannbereich Clamping range
R/LH223.1010.01	10	10	80	20	12	9,20	f ₁ +w/2	8	25	12	01	2,0
R/LH223.1212.01	12	12	100	21	16	11,20	f ₁ +w/2	10	50	-	01	2,0
R/LH223.1616.01	16	16	125	-	16	15,20	f ₁ +w/2	10	50	-	01	2,0
R/LH223.2020.01	20	20	125	-	20	19,20	f ₁ +w/2	10	50	-	01	2,0
R/LH223.2525.01	25	25	150	-	25	24,20	f ₁ +w/2	10	50	-	01	2,0
R/LH223.1010.02	10	10	80	20	12	9,05	f ₁ +w/2	8	25	12	02	2,5
R/LH223.1212.02	12	12	100	21	16	11,05	f ₁ +w/2	10	50	-	02	2,5
R/LH223.1616.02	16	16	125	-	16	15,05	f ₁ +w/2	10	50	-	02	2,5
R/LH223.2020.02	20	20	125	-	20	19,05	f ₁ +w/2	10	50	-	02	2,5
R/LH223.2525.02	25	25	150	-	25	24,05	f ₁ +w/2	10	50	-	02	2,5
R/LH223.1010.03	10	10	80	20	12	8,80	f ₁ +w/2	8	25	12	03	3,0
R/LH223.1212.03	12	12	100	21	16	10,80	f ₁ +w/2	10	50	-	03	3,0
R/LH223.1616.03	16	16	125	-	16	14,80	f ₁ +w/2	10	50	-	03	3,0
R/LH223.2020.03	20	20	125	-	20	18,80	f ₁ +w/2	10	50	-	03	3,0
R/LH223.2525.03	25	25	150	-	25	23,80	f ₁ +w/2	10	50	-	03	3,0

Ausführung R oder L angeben
State R or L version

w siehe WSP
w see indexable inserts

Abmessungen in mm
Dimensions in mm

Weitere Abmessungen auf Anfrage
Further sizes upon request

Das Anzugsdrehmoment der Schrauben finden Sie in den Technischen Hinweisen.
For torque specification of the screw, please see Technical Instructions.

Ersatzteile

Spare Parts

Klemmhalter Toolholder	Spannschraube Screw	TORX PLUS®-Schlüssel TORX PLUS® Wrench
R/LH223...	5.11T15P	T15PL

Einstechen und Abstechen

Grooving and Parting Off



Klemmhalter

Toolholder

H223

verstärkte Ausführung
reinforced version

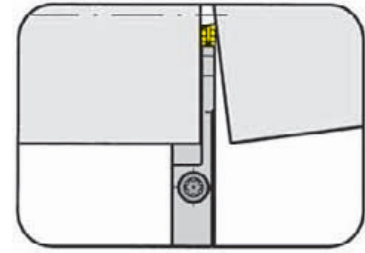

Stechtiefe bis
Spannbereich

Depth of groove up to
Clamping range

25,0 mm
2,0 - 3,0 mm

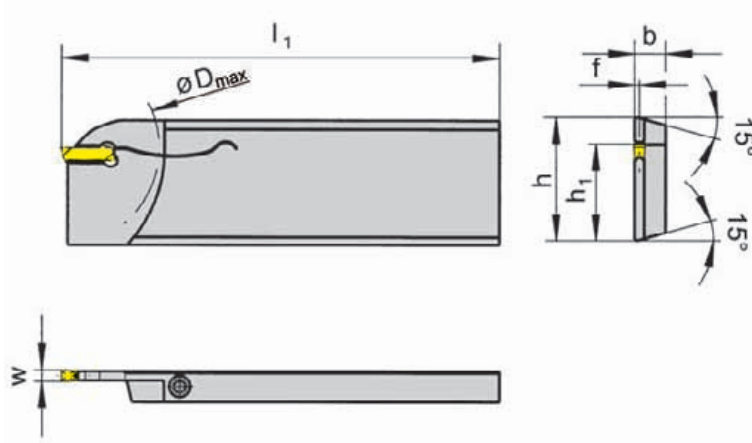

für Schneidplatte
for Insert

Typ S223
Type S123

R = rechts wie gezeichnet
R = right hand version shown

L = links spiegelbildlich
L = left hand version

Bestellnummer Part number	h	b	l ₁	h ₁	f	D _{max}	Größe Size	Spannbereich Clamping range
R/LH223.2608.01	26	7,9	110	21,4	0,80	50	01	2,0
R/LH223.3208.01	32	7,9	110	24,8	0,80	50	01	2,0
R/LH223.2608.02	26	7,9	110	21,4	0,95	50	02	2,5
R/LH223.3208.02	32	7,9	110	24,8	0,95	50	02	2,5
R/LH223.2608.03	26	7,9	110	21,4	1,20	50	03	3,0
R/LH223.3208.03	32	7,9	110	24,8	1,20	50	03	3,0

Ausführung R oder L angeben
State R or L version

w siehe WSP
w see indexable inserts

Abmessungen in mm
Dimensions in mm

Weitere Abmessungen auf Anfrage
Further sizes upon request

Das Anzugsdrehmoment der Schrauben finden Sie in den Technischen Hinweisen.
For torque specification of the screw, please see Technical Instructions.

Abstechen von:
parting off:

Wellen oder Ringen (S223)
solid bars or tubes

Wellen (S123)
solid bars

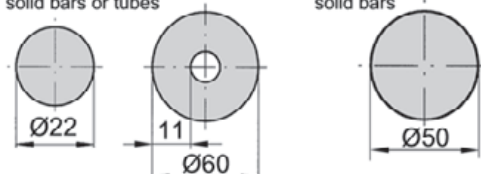

Ersatzteile

Spare Parts

Klemmhalter Toolholder	Spannschraube Screw	TORX PLUS®-Schlüssel TORX PLUS® Wrench
R/LH223...	4.15T15P	T15PL

Einstecken und Längsdrehen (außen)

Grooving and Side Turning (external)



Kurzklemmhalter

Cartridge

E223

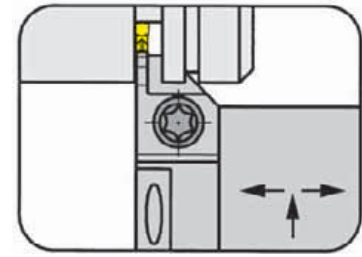

Stechtiefe bis Spannbereich	Depth of groove up to Clamping range	10 mm 2,0 - 3,0 mm
--------------------------------	---	-----------------------

für Schneidplatte
for Insert

Typ S223
Type S123

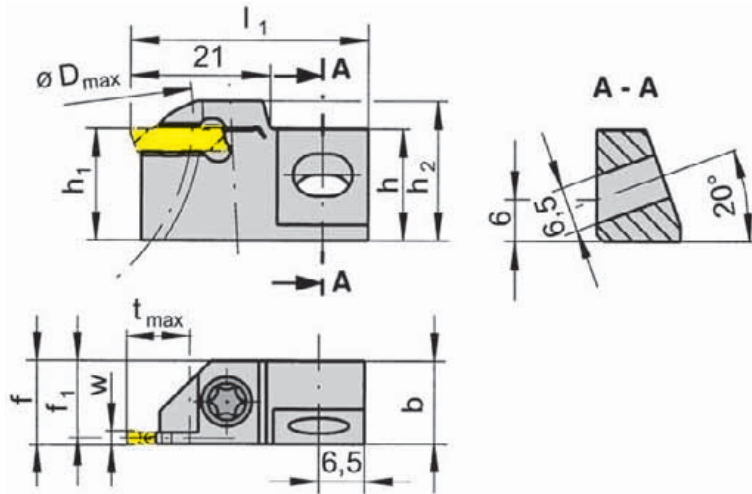

R = rechts wie gezeichnet
R = right hand version shown

L = links spiegelbildlich
L = left hand version

Bestellnummer Part number	h	b	l_1	h_1	f_1	f	t_{max}	D_{max}	h_2	Größe Size	Spannbereich Clamping range
R/LE223.1212.01	16	12	34	12	11,20	$f_1+w/2$	10	50	17,3	01	2,0-2,0
R/LE223.1616.01	16	12	34	16	11,20	$f_1+w/2$	10	50	21,3	01	2,0-2,0
R/LE223.1212.02	16	12	34	12	11,05	$f_1+w/2$	10	50	17,3	02	2,5-2,5
R/LE223.1616.02	16	12	34	16	11,05	$f_1+w/2$	10	50	21,3	02	2,5-2,5
R/LE223.1212.03	16	12	34	12	10,80	$f_1+w/2$	10	50	17,3	03	3,0-3,0
R/LE223.1616.03	16	12	34	16	10,80	$f_1+w/2$	10	50	21,3	03	3,0-3,0

Ausführung R oder L angeben
State R or L version

w siehe WSP
w see indexable inserts

Abmessungen in mm
Dimensions in mm

Weitere Abmessungen auf Anfrage
Further sizes upon request

Das Anzugsdrehmoment der Schrauben finden Sie in den Technischen Hinweisen.
For torque specification of the screw, please see Technical Instructions.

Ersatzteile

Spare Parts

Kurzklemmhalter Cartridge	Spannschraube Screw	Schraube Screw	TORX PLUS®-Schlüssel TORX PLUS® Wrench
R/LE223...	5.11T15P	6.20.232	T15PL

Einstecken und Längsdrehen (innen)

Grooving and Side Turning (internal)



Klemmhalter

Toolholder

B119

mit innerer Kühlmittelzufuhr
with through coolant supply

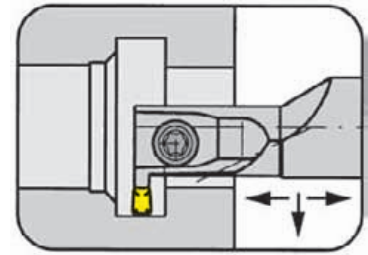

Bohrungs-Ø ab
Stechtiefe bis
Spannbereich

Bore Ø from
Depth of groove up to
Clamping range

16 mm
3 mm
2,0 - 3,0 mm

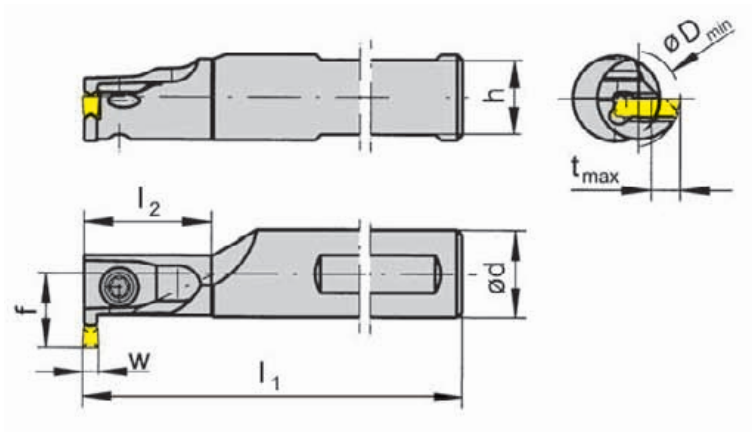

für Schneidplatte
for Insert

Typ S119
Type

R = rechts wie gezeichnet
R = right hand version shown

L = links spiegelbildlich
L = left hand version

Bestellnummer Part number	d	l ₁	l ₂	h	t _{max}	D _{min}	f	Größe Size	Spannbereich Clamping range
R/LB119.0016.1.32	16	110	25	14	3	16	11,8	02	2,00-2,99
R/LB119.0016.1.33	16	110	25	14	3	16	11,8	03	3,00-3,00

Ausführung R oder L angeben
State R or L version

w siehe Schneidplatten
w see inserts

Abmessungen in mm
Dimensions in mm

Weitere Abmessungen auf Anfrage
Further sizes upon request

Das Anzugsdrehmoment der Schrauben finden Sie in den Technischen Hinweisen.
For torque specification of the screw, please see Technical Instructions.

Ersatzteile

Spare Parts

Klemmhalter Toolholder	Spannschraube Screw	TORX PLUS®-Schlüssel TORX PLUS® Wrench
R/LB119...	5.11T15P	T15PL

Einstecken und Längsdrehen (innen)

Grooving and Side Turning (internal)



Klemmhalter

Toolholder

B223

mit innerer Kühlmittelzufuhr
with through coolant supply

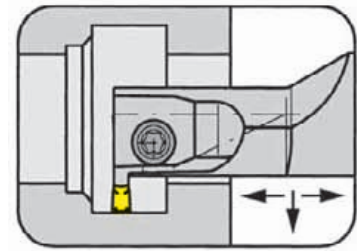

Bohrungs-Ø ab
Stechtiefe bis
Spannbereich

Bore Ø from
Depth of groove up to
Clamping range

22 mm
6,3 mm
2,0 - 3,0 mm

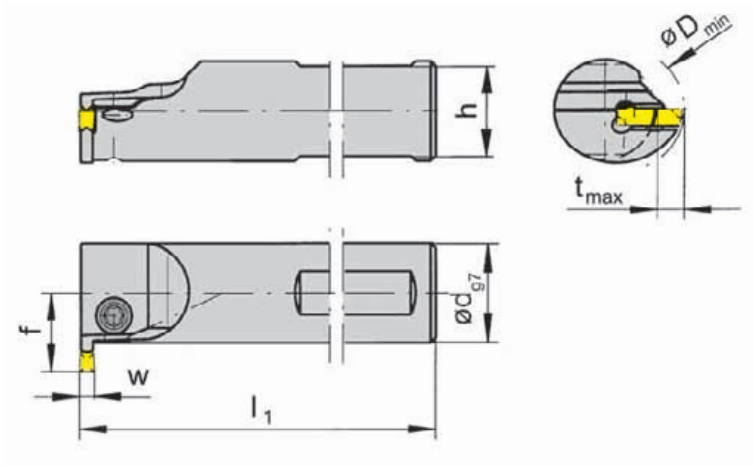

für Wendeschneidplatte
for Indexable insert

Typ S223
Type S123

R = rechts wie gezeichnet
R = right hand version shown

L = links spiegelbildlich
L = left hand version

Bestellnummer Part number	d	l ₁	h	f	t _{max}	D _{min}	Größe Size	Spannbereich Clamping range
R/LB223.0016.0.42	16	110	14	13,0	4,5	22	02	2,00-2,99
R/LB223.0020.0.52	20	120	18	15,7	5,3	27	02	2,00-2,99
R/LB223.0025.0.62	25	150	23	19,3	6,3	33	02	2,00-2,99
R/LB223.0016.0.43	16	110	14	13,0	4,5	22	03	3,00-3,00
R/LB223.0020.0.53	20	120	18	15,7	5,3	27	03	3,00-3,00
R/LB223.0025.0.63	25	150	23	19,3	6,3	33	03	3,00-3,00

Ausführung R oder L angeben
State R or L version

w siehe WSP
w see indexable inserts

Abmessungen in mm
Dimensions in mm

Weitere Abmessungen auf Anfrage
Further sizes upon request

Das Anzugsdrehmoment der Schrauben finden Sie in den Technischen Hinweisen.
For torque specification of the screw, please see Technical Instructions.

Ersatzteile

Spare Parts

Klemmhalter Toolholder	Spannschraube Screw	TORX PLUS®-Schlüssel TORX PLUS® Wrench
R/LB223.0...	5.11T15P	T15PL
R/LB223.0025.0.63	5.11T15P	T15PQ

Einstecken und Längsdrehen (innen)

Grooving and Side Turning (internal)



Klemmhalter

Toolholder

B223

mit innerer Kühlmittelzufuhr
with through coolant supply

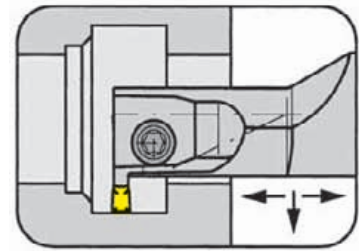

Bohrungs-Ø ab
Stechtiefe bis
Spannbereich

Bore Ø from
Depth of groove up to
Clamping range

18 mm
6,3 mm
2,0 - 3,0 mm

für Wendeschneidplatte
for Indexable insert

Typ S223
Type S123

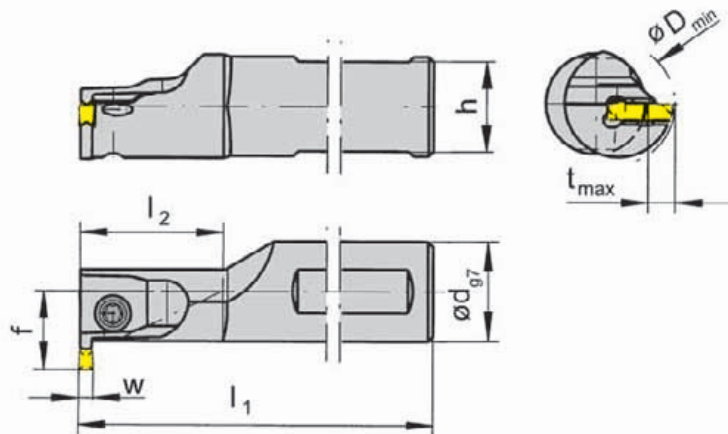

R = rechts wie gezeichnet
R = right hand version shown

L = links spiegelbildlich
L = left hand version

Bestellnummer Part number	d	l ₁	l ₂	h	f	t _{max}	D _{min}	Größe Size	Spannbereich Clamping range
R/LB223.0016.1.42	16	110	25	14	13,0	4,5	18	02	2,00-2,99
R/LB223.0020.1.52	20	120	30	18	15,7	5,3	20	02	2,00-2,99
R/LB223.0025.1.62	25	150	50	23	18,8	6,3	25	02	2,00-2,99
R/LB223.0016.1.43	16	110	25	14	13,0	4,5	18	03	3,00-3,00
R/LB223.0020.1.53	20	120	30	18	15,7	5,3	20	03	3,00-3,00
R/LB223.0025.1.63	25	150	50	23	18,8	6,3	25	03	3,00-3,00

Ausführung R oder L angeben
State R or L version

w siehe WSP
w see indexable inserts

Abmessungen in mm
Dimensions in mm

Weitere Abmessungen auf Anfrage
Further sizes upon request

Das Anzugsdrehmoment der Schrauben finden Sie in den Technischen Hinweisen.
For torque specification of the screw, please see Technical Instructions.

Ersatzteile

Spare Parts

Klemmhalter Toolholder	Spannschraube Screw	TORX PLUS®-Schlüssel TORX PLUS® Wrench
R/LB223...	5.11T15P	T15PL

Einstecken (innen)

Grooving (internal)



Klemmhalter

Toolholder

B223

mit innerer Kühlmittelzufuhr
with through coolant supply

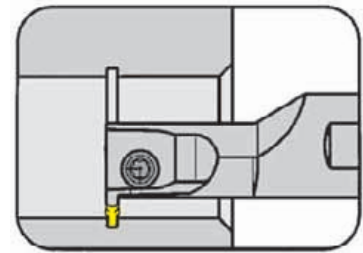

Bohrungs-Ø ab
Seegerringnuten
Spannbereich

Bore Ø from
Circlip grooves
Clamping range

18 mm
DIN 471/472
2,0 - 2,9 mm

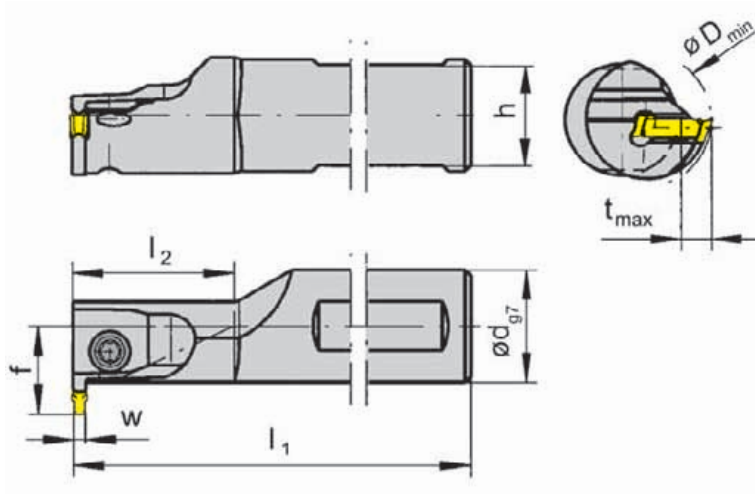

für Wendeschneidplatte
for Indexable insert

Typ S223
Type S123

R = rechts wie gezeichnet
R = right hand version shown

L = links spiegelbildlich
L = left hand version

Bestellnummer Part number	d	l ₁	l ₂	h	f	t _{max}	D _{min}	Größe Size	Spannbereich Clamping range
R/LB223.0016.1.22	16	110	25	14	13,0	1,65	18	02	2,00-2,99
R/LB223.0020.1.22	20	120	30	18	15,7	1,65	20	02	2,00-2,99

Ausführung R oder L angeben
State R or L version

w siehe WSP
w see indexable inserts

Abmessungen in mm
Dimensions in mm

Weitere Abmessungen auf Anfrage
Further sizes upon request

Das Anzugsdrehmoment der Schrauben finden Sie in den Technischen Hinweisen.
For torque specification of the screw, please see Technical Instructions.

Ersatzteile

Spare Parts

Klemmhalter Toolholder	Spannschraube Screw	TORX PLUS®-Schlüssel TORX PLUS® Wrench
R/LB223...	5.11T15P	T15PL

Einstecken und Längsdrehen (innen)

Grooving and Side Turning (internal)



Klemmhalter

Toolholder

B223

mit innerer Kühlmittelzufuhr
with through coolant supply

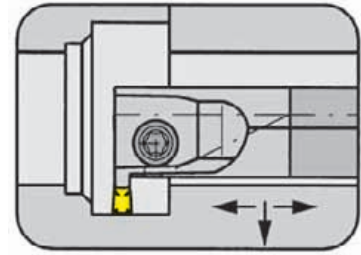

Bohrungs-Ø ab
Stechtiefe bis
Spannbereich

Bore Ø from
Depth of groove up to
Clamping range

18 mm
6,3 mm
2,0 - 3,0 mm

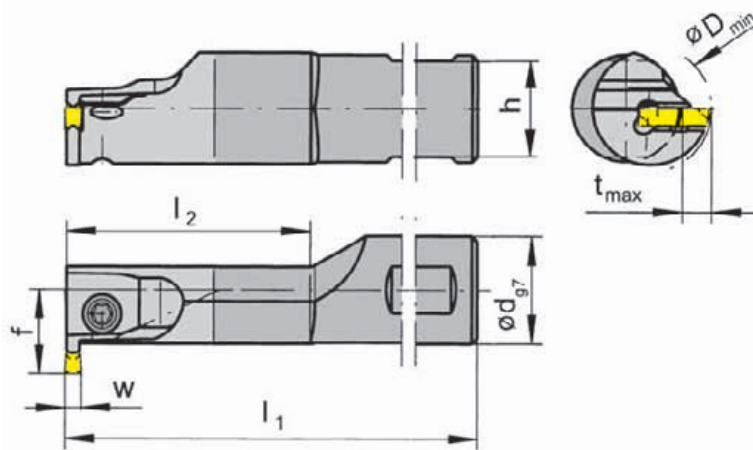

für Wendeschneidplatte
for Indexable insert

Typ S223
Type S123

Hartmetallschaft
Carbide shank

R = rechts wie gezeichnet
R = right hand version shown

L = links spiegelbildlich
L = left hand version

Bestellnummer Part number	d	l ₁	l ₂	h	f	t _{max}	D _{min}	Größe Size	Spannbereich Clamping range
R/LB223.HM16.2.42	16	130	50	14	13,0	4,5	18	02	2,00-2,99
R/LB223.HM20.2.52	20	150	60	18	15,7	5,3	20	02	2,00-2,99
R/LB223.HM25.2.62	25	160	70	23	18,8	6,3	25	02	2,00-2,99
R/LB223.HM16.2.43	16	130	50	14	13,0	4,5	18	03	3,00-3,00
R/LB223.HM20.2.53	20	150	60	18	15,7	5,3	20	03	3,00-3,00
R/LB223.HM25.2.63	25	160	70	23	18,8	6,3	25	03	3,00-3,00

Ausführung R oder L angeben
State R or L version

w siehe WSP
w see indexable inserts

Abmessungen in mm
Dimensions in mm

Weitere Abmessungen auf Anfrage
Further sizes upon request

Das Anzugsdrehmoment der Schrauben finden Sie in den Technischen Hinweisen.
For torque specification of the screw, please see Technical Instructions.

Ersatzteile

Spare Parts

Klemmhalter Toolholder	Spannschraube Screw	TORX PLUS®-Schlüssel TORX PLUS® Wrench
R/LB223...	5.11T15P	T15PL

Einstecken und Längsdrehen (innen)

Grooving and Side Turning (internal)



Grundhalter

Basic toolholder

B223

ohne Kasette
without cassette

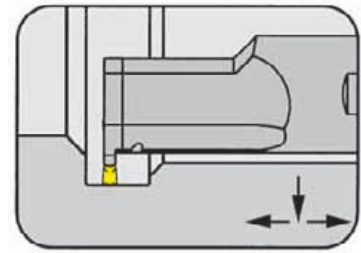

Bohrungs-Ø	Bore Ø	28,0 mm
Stechtiefe bis	Depth of groove up to	6,3 mm
Stechbreite	Width of groove	2,0 - 3,0 mm

mit innerer Kühlmittelzufuhr
with through coolant supply

für Kasette
for Cassette

Typ BK223
Type

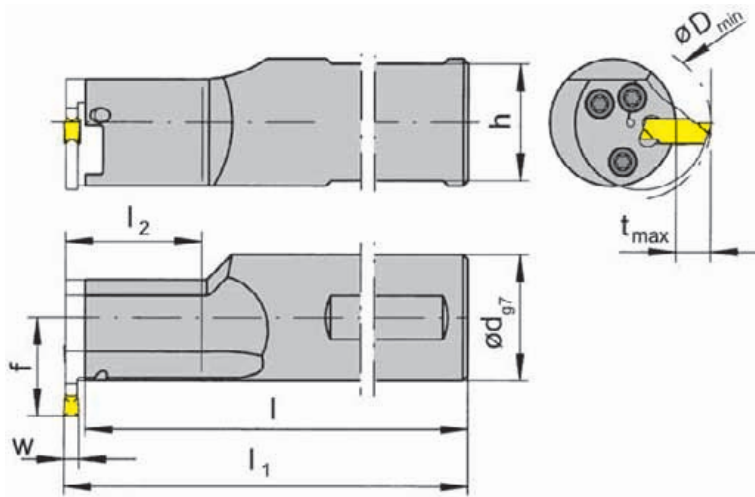

R = rechts wie gezeichnet
R = right hand version shown

L = links spiegelbildlich
L = left hand version

Bestellnummer Part number	d	l	l ₁	l ₂	h	f
R/LB223.0025.1.K2	25	116,1	$l+b_1+w/2$	30	23	19,5
R/LB223.0025.2.K2	25	146,1	$l+b_1+w/2$	60	23	19,5
R/LB223.0032.1.K2	32	146,1	$l+b_1+w/2$	30	30	23,0
R/LB223.0032.2.K2	32	176,1	$l+b_1+w/2$	60	30	23,0

Ausführung R oder L angeben
State R or L version

w siehe WSP
w see indexable inserts

Abmessungen in mm
Dimensions in mm

Weitere Abmessungen auf Anfrage
Further sizes upon request

Hinweis:

Abmessungen für D_{min} , t_{max} und b_1 siehe Kassetten

Note:

Dimensions for D_{min} , t_{max} and b_1 see cassettes

Das Anzugsdrehmoment der Schrauben finden Sie in den Technischen Hinweisen.
For torque specification of the screw, please see Technical Instructions.

Ersatzteile

Spare Parts

Klemmhalter Toolholder	Spannschraube Screw	TORX PLUS®-Schlüssel TORX PLUS® Wrench
R/LB223...	5.11T15P	T15PL

Einstecken und Längsdrehen (innen)

Grooving and Side Turning (internal)



Kassette

Cassette

BK223

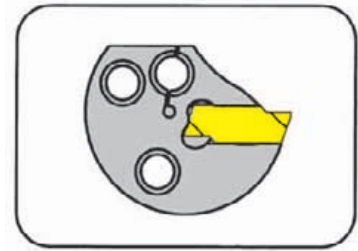

Bohrungs-Ø	Bore Ø	28 mm
Stechtiefe bis	Depth of groove up to	6,3 mm
Spannbereich	Clamping range	2,0 - 3,0 mm

für Wendeschneidplatte
for Indexable insert

Typ S223
Type

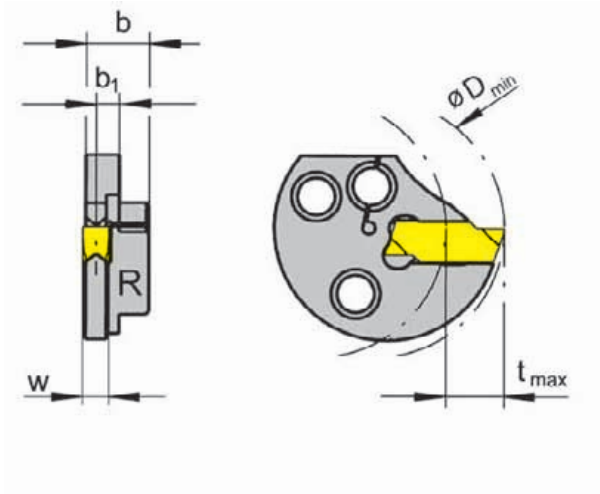

R = rechts wie gezeichnet
R = right hand version shown

L = links spiegelbildlich
L = left hand version

Bestellnummer Bestellnummer	b ₁	b	D _{min}	t _{max}	Größe Size	Spannbereich Clamping range
R/LBK223.0028.01	3,10	7,4	28	6,3	01	2,0
R/LBK223.0028.02	2,95	7,4	28	6,3	02	2,5
R/LBK223.0028.03	2,70	7,4	28	6,3	03	3,0

Ausführung R oder L angeben
State R or L version

w siehe WSP
w see indexable inserts

Abmessungen in mm
Dimensions in mm

Rechte Kassetten in rechten und linke Kassetten in linken Grundhaltern verwenden.
Rechte Kassetten in rechten und linke Kassetten in linken Grundhaltern verwenden.

Ersatzteile

Befestigungsschrauben der Kassetten gehören zum Lieferumfang des Grundhalters.

Spare Parts

The fastening screw is combined with the basic toolholder - no separate order required.

Einstechen und Längsdrehen

Grooving and Side Turning



Schneidplatte

Insert

S119

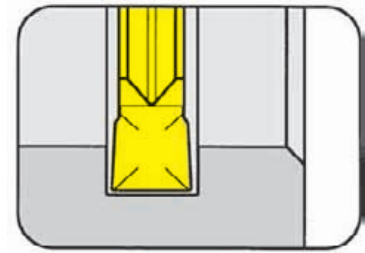

Stechtiefe bis Stechbreite	Depth of groove up to Width of groove	3,0 mm 2-3 mm
-------------------------------	--	------------------

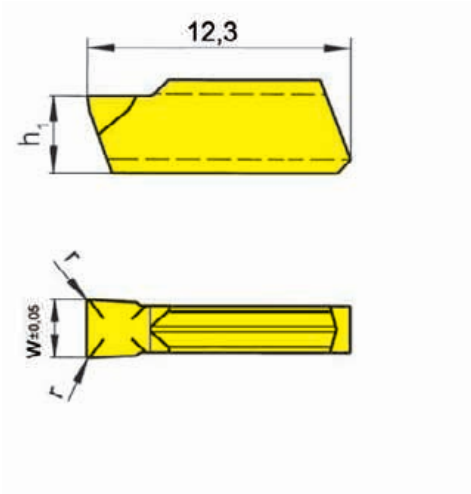

für Klemmhalter
for Toolholder

Typ B119
Type

Bestellnummer Part number	w	r	h ₁	Größe Size	TN35
S119.0200.32	2,0	0,2	3,65	02	▲
S119.0250.32	2,5	0,2	3,75	02	▲
S119.0300.32	3,0	0,2	3,95	03	▲

▲ ab Lager / on stock Δ 4 Wochen / 4 weeks x auf Anfrage / upon request

● empfohlen / recommended

o bedingt einsetzbar / alternative recommendation

- nicht geeignet / not suitable

□ unbeschichtete HM-Sorten / uncoated grades

■ beschichtete HM-Sorten / coated grades

■ bestückt/Cermet / brazed/Cermet

Abmessungen in mm

Dimensions in mm

Schneidplatten sind in **rechten und linken** Klemmhaltern verwendbar.

Indexable inserts can be used in **right and left** hand toolholders.

P	•
M	•
K	•
N	•
S	•
H	-

HM-Sorten
Carbide grades

Einstechen und Abstechen

Grooving and Parting Off



Schneidplatte

Insert

S123

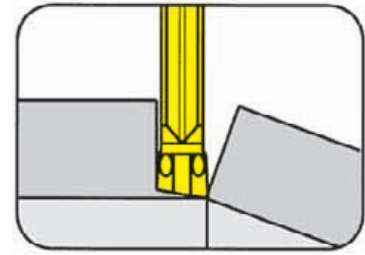

Stechtiefe bis Stechbreite	Depth of groove up to Width of groove	25,0 mm 2-3 mm
-------------------------------	--	-------------------

für Klemhalter
for Toolholder

Typ H223
Type

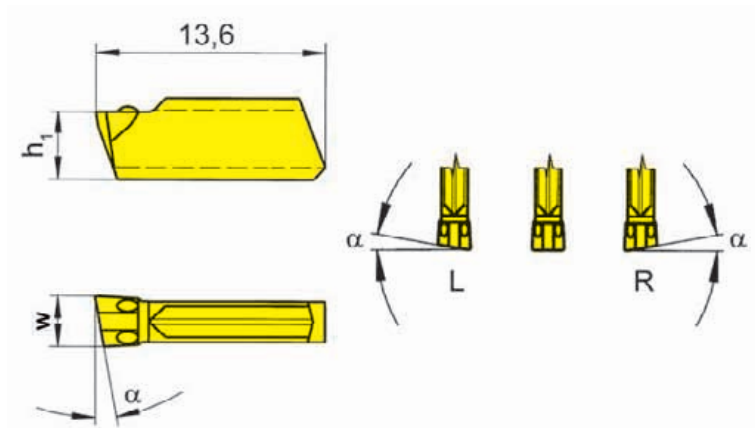

R = rechts wie gezeichnet
R = right hand version shown

L = links spiegelbildlich
L = left hand version

Bestellnummer Part number	w	α	h ₁	Größe Size	TF45	TI25	TN35
S123.0020.C0	2	0°	3,65	01	Δ	Δ	Δ
R/LS123.0420.C0	2	4°	3,65	01	Δ/Δ	Δ/Δ	Δ/Δ
R/LS123.0820.C0	2	8°	3,65	01	Δ/Δ	Δ/Δ	Δ/Δ
R/LS123.1520.C0	2	15°	3,65	01	▲/Δ	Δ/Δ	▲/Δ
S123.0030.C0	3	0°	3,95	03	Δ	Δ	Δ
R/LS123.0430.C0	3	4°	3,95	03	Δ/Δ	Δ/Δ	Δ/Δ
R/LS123.0830.C0	3	8°	3,95	03	Δ/Δ	Δ/Δ	Δ/Δ

▲ ab Lager / on stock Δ 4 Wochen / 4 weeks x auf Anfrage / upon request

● empfohlen / recommended

o bedingt einsetzbar / alternative recommendation

- nicht geeignet / not suitable

□ unbeschichtete HM-Sorten / uncoated grades

■ beschichtete HM-Sorten / coated grades

■ bestückt/Cermet / brazed/Cermet

Abmessungen in mm

Dimensions in mm

Ausführung R oder L angeben

State R or L version

Schneidplatten sind in **rechten und linken** Klemmhaltern verwendbar.

Indexable inserts can be used in **right and left** hand toolholders.

P	●	●	●
M	●	●	●
K	●	●	●
N	●	●	●
S	●	●	●
H	-	-	-

HM-Sorten
Carbide grades

Einstechen und Abstechen

Grooving and Parting Off



Schneidplatte

Insert

S123

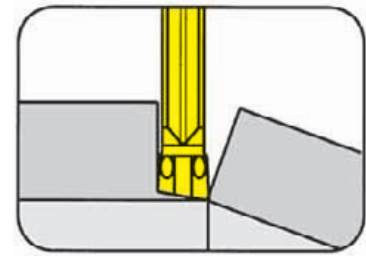

Stechtiefe bis Stechbreite	Depth of groove up to Width of groove	25,0 mm 2-3 mm
-------------------------------	--	-------------------

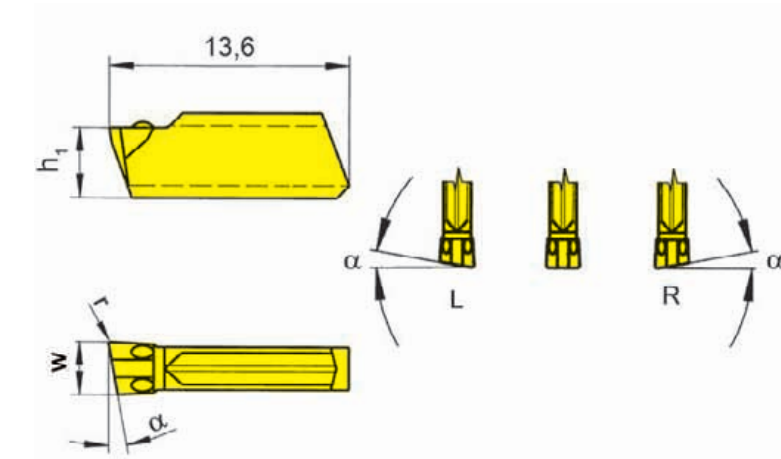

für Klemmhalter
for Toolholder

Typ H223
Type

R = rechts wie gezeichnet
R = right hand version shown

L = links spiegelbildlich
L = left hand version

Bestellnummer Part number	w	r	α	h_1	Größe Size	TF45	Tl25	TN35
S123.0020.C1	2	0,15	0°	3,65	01	Δ	Δ	Δ
R/LS123.0420.C1	2	0,15	4°	3,65	01	Δ/Δ	Δ/Δ	Δ/Δ
R/LS123.0820.C1	2	0,15	8°	3,65	01	Δ/Δ	Δ/Δ	Δ/Δ
R/LS123.1520.C1	2	0,15	15°	3,65	01	Δ/Δ	Δ/Δ	Δ/Δ
S123.0030.C1	3	0,15	0°	3,95	03	Δ	Δ	Δ
R/LS123.0430.C1	3	0,15	4°	3,95	03	Δ/Δ	Δ/Δ	Δ/Δ
R/LS123.0830.C1	3	0,15	8°	3,95	03	Δ/Δ	Δ/Δ	Δ/Δ

▲ ab Lager / on stock Δ 4 Wochen / 4 weeks x auf Anfrage / upon request

● empfohlen / recommended

o bedingt einsetzbar / alternative recommendation

- nicht geeignet / not suitable

■ unbeschichtete HM-Sorten / uncoated grades

■ beschichtete HM-Sorten / coated grades

■ bestückt/Cermet / brazed/Cermet

Abmessungen in mm

Dimensions in mm

Ausführung R oder L angeben

State R or L version

Schneidplatten sind in **rechten und linken** Klemmhaltern verwendbar.

Indexable inserts can be used in **right and left** hand toolholders.

P	•	•	•
M	•	•	•
K	•	•	•
N	•	•	•
S	•	•	•
H	-	-	-

HM-Sorten
Carbide grades

Einstechen und Längsdrehen

Grooving and Side Turning



Wendeschneidplatte

Indexable insert

S223

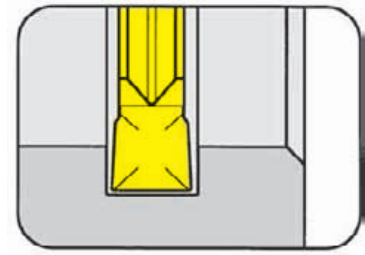

Stechtiefe bis Stechbreite	Depth of groove up to Width of groove	11,0 mm 2-3 mm
-------------------------------	--	-------------------

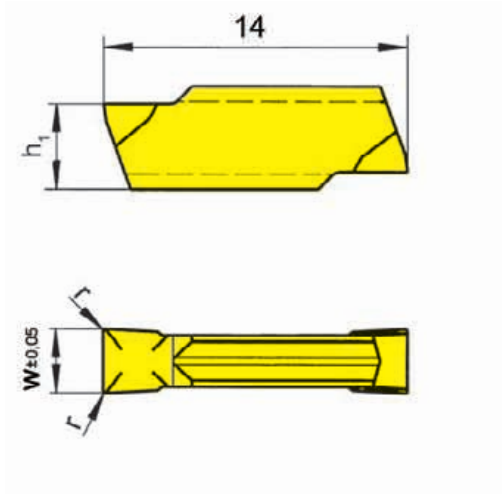

für Klemmhalter
for Toolholder

Typ H223
Type E223
B223
BK223

Bestellnummer Part number	w	r	h ₁	Größe Size	MG12	H54	Ti25	TN35
S223.0200.32	2,0	0,2	3,65	01	▲	▲	▲	▲
S223.0250.32	2,5	0,2	3,75	02	▲	▲	▲	▲
S223.0300.32	3,0	0,2	3,95	03	▲	▲	▲	▲
					P	○	●	●
					M	●	●	●
					K	●	-	●
					N	●	-	●
					S	●	-	●
					H	-	-	-

▲ ab Lager / on stock Δ 4 Wochen / 4 weeks x auf Anfrage / upon request

● empfohlen / recommended

○ bedingt einsetzbar / alternative recommendation

- nicht geeignet / not suitable

□ unbeschichtete HM-Sorten / uncoated grades

■ beschichtete HM-Sorten / coated grades

■ bestückt/Cermet / brazed/Cermet

Abmessungen in mm

Dimensions in mm

Wendeschneidplatten sind in rechten und linken Klemmhaltern verwendbar.

Indexable inserts can be used in right and left hand toolholders.

HM-Sorten
Carbide grades

Wendeschneidplatte

Indexable insert

S223

Zapfenausführung
limited depth of cut

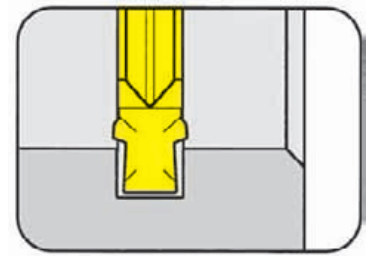

Seegerringnuten
Nutnennbreite Nw

Circlip grooves
Width of circlip Nw

DIN 471/472
1,1-2,15 mm

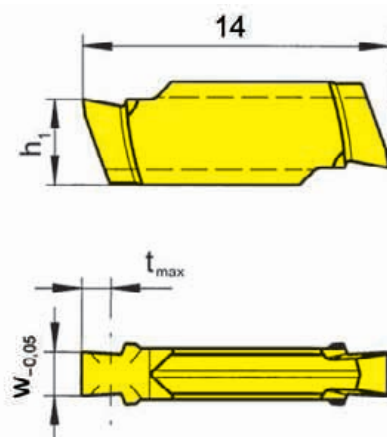

für Klemmhalter
for Toolholder

Typ H223
Type E223
B223...1.22

Bestellnummer Part number	w	Nw	t _{max}	h ₁	Größe Size	TN35
S223.0110.32	1,24	1,10	0,60	3,75	02	▲
S223.0130.32	1,44	1,30	1,10	3,75	02	▲
S223.0160.32	1,74	1,60	1,15	3,75	02	▲
S223.0185.32	1,99	1,85	1,40	3,75	02	▲
S223.0215.32	2,29	2,15	1,65	3,75	02	▲

▲ ab Lager / on stock Δ 4 Wochen / 4 weeks x auf Anfrage / upon request

● empfohlen / recommended

o bedingt einsetzbar / alternative recommendation

- nicht geeignet / not suitable

■ unbeschichtete HM-Sorten / uncoated grades

■ beschichtete HM-Sorten / coated grades

■ bestückt/Cermet / brazed/Cermet

Abmessungen in mm

Dimensions in mm

Wendeschneidplatten sind in rechten und linken Klemmhaltern verwendbar.

Indexable inserts can be used in right and left hand toolholders.

P	•
M	•
K	•
N	•
S	•
H	-

HM-Sorten
Carbide grades

Einstechen und Längsdrehen

Grooving and Side Turning



Wendeschneidplatte

Indexable insert

S223

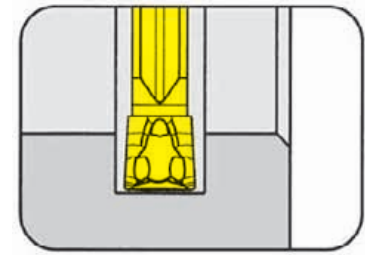

Stechtiefe bis Stechbreite	Depth of groove up to Width of groove	11,0 mm 2-3 mm
-------------------------------	--	-------------------

für Klemmhalter
for Toolholder

Typ H223
Type E223
B223
BK223

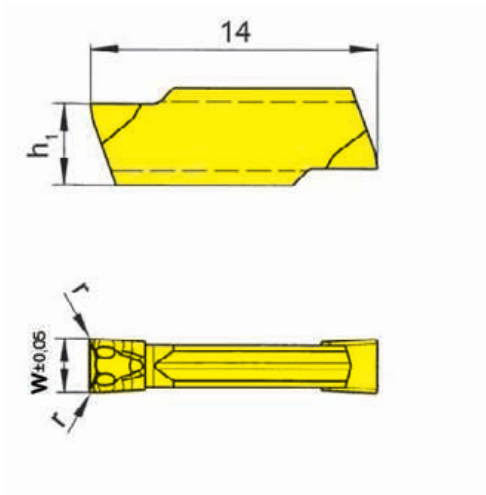

Bestellnummer Part number	w	r	h ₁	Größe Size	TH35	TI25
S223.0200.52	2,0	0,2	3,65	01	▲	▲
S223.0250.52	2,5	0,2	3,75	02	▲	▲
S223.0300.52	3,0	0,2	3,95	03	▲	▲
					P	•
					M	•
					K	•
					N	•
					S	•
					H	-

▲ ab Lager / on stock Δ 4 Wochen / 4 weeks x auf Anfrage / upon request

● empfohlen / recommended

o bedingt einsetzbar / alternative recommendation

- nicht geeignet / not suitable

□ unbeschichtete HM-Sorten / uncoated grades

■ beschichtete HM-Sorten / coated grades

■ bestückt/Cermet / brazed/Cermet

Abmessungen in mm

Dimensions in mm

Wendeschneidplatten sind in rechten und linken Klemmhaltern verwendbar.

Indexable inserts can be used in right and left hand toolholders.

HM-Sorten
Carbide grades

C

Einstechen und Längsdrehen

Grooving and Side Turning



Wendeschneidplatte

Indexable insert

S223

mit Spanformung
with chip forming

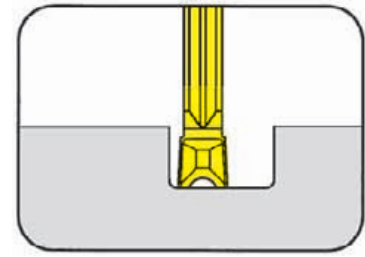

Stechtiefe bis Stechbreite	Depth of groove up to Width of groove	10,0 mm 2,0 mm
-------------------------------	--	-------------------

präzisionsgeschliffen
precision ground

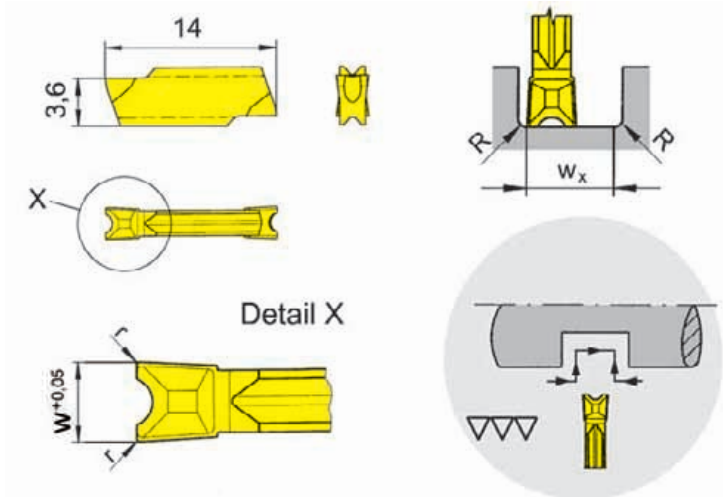

für Klemmhalter
for Toolholder

Typ H223
Type E223
B223
BK223

Bestellnummer Part number	w	r	t _{max}	w _x	Größe Size	T125
S223.NC20.D2	2	0,2	10	2,7	01	▲

▲ ab Lager / on stock Δ 4 Wochen / 4 weeks x auf Anfrage / upon request

● empfohlen / recommended

o bedingt einsetzbar / alternative recommendation

- nicht geeignet / not suitable

■ unbeschichtete HM-Sorten / uncoated grades

■ beschichtete HM-Sorten / coated grades

■ bestückt/Cermet / brazed/Cermet

Abmessungen in mm

Dimensions in mm

$$w_x = \text{Nutbreite} - R_{(\text{rechts})} - R_{(\text{links})}$$

$$w_x = \text{width of groove} - R_{(\text{right})} - R_{(\text{left})}$$

Wendeschneidplatten sind in rechten und linken Klemmhaltern verwendbar.

Indexable inserts can be used in right and left hand toolholders.

P	•
M	•
K	•
N	•
S	•
H	-

HM-Sorten
Carbide grades



Einstechen und Abstechen

Grooving and Parting Off



Wendeschneidplatte

Indexable insert

S223

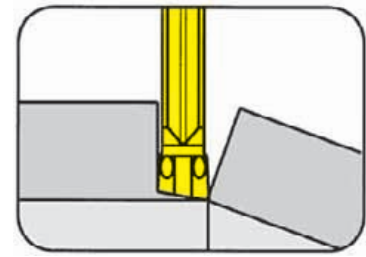

Stechtiefe bis Stechbreite	Depth of groove up to Width of groove	11,0 mm 2-3 mm
-------------------------------	--	-------------------

für Klemmhalter
for Toolholder

Typ H223
Type

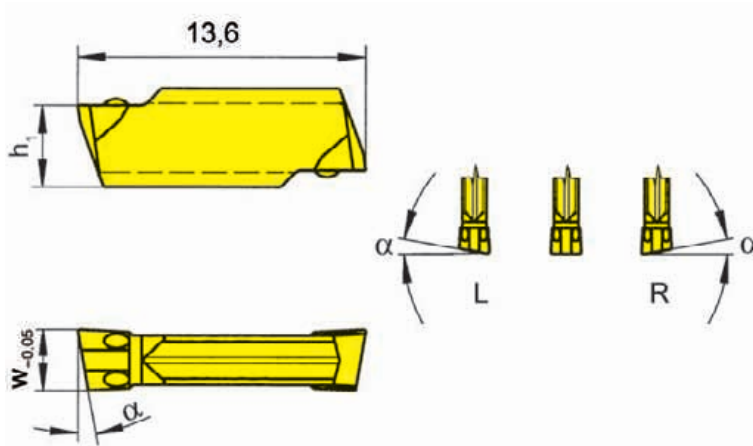

R = rechts wie gezeichnet
R = right hand version shown

L = links spiegelbildlich
L = left hand version

Bestellnummer Part number	w	α	h_1	Größe Size	TF45	TI25	TN35
S223.0020.C0	2,0	0°	3,65	01	▲	▲	▲
R/LS223.0420.C0	2,0	4°	3,65	01	▲/▲	▲/▲	▲/▲
R/LS223.0820.C0	2,0	8°	3,65	01	▲/▲	▲/▲	▲/▲
R/LS223.1520.C0	2,0	15°	3,65	01	▲/▲	▲/▲	▲/▲
S223.0025.C0	2,5	0°	3,75	02	▲	▲	▲
R/LS223.0425.C0	2,5	4°	3,75	02	▲/▲	▲/▲	▲/▲
R/LS223.0825.C0	2,5	8°	3,75	02	▲/▲	▲/▲	▲/▲
S223.0030.C0	3,0	0°	3,95	03	▲	▲	▲
R/LS223.0430.C0	3,0	4°	3,95	03	▲/▲	▲/▲	▲/▲
R/LS223.0830.C0	3,0	8°	3,95	03	▲/▲	▲/▲	▲/▲
					P	•	•
					M	•	•
					K	•	•
					N	•	•
					S	•	•
					H	-	-

▲ ab Lager / on stock Δ 4 Wochen / 4 weeks x auf Anfrage / upon request

● empfohlen / recommended

o bedingt einsetzbar / alternative recommendation

- nicht geeignet / not suitable

■ unbeschichtete HM-Sorten / uncoated grades

■ beschichtete HM-Sorten / coated grades

■ bestückt/Cermet / brazed/Cermet

Abmessungen in mm

Dimensions in mm

Ausführung R oder L angeben

State R or L version

Wendeschneidplatten sind in rechten und linken Klemmhaltern verwendbar.

Indexable inserts can be used in right and left hand toolholders.

HM-Sorten
Carbide grades

Einstechen und Abstechen

Grooving and Parting Off



Wendeschneidplatte

Indexable insert

S223

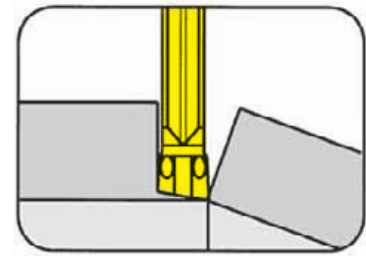

Stechtiefe bis Stechbreite	Depth of groove up to Width of groove	11,0 mm 2-3 mm
-------------------------------	--	-------------------

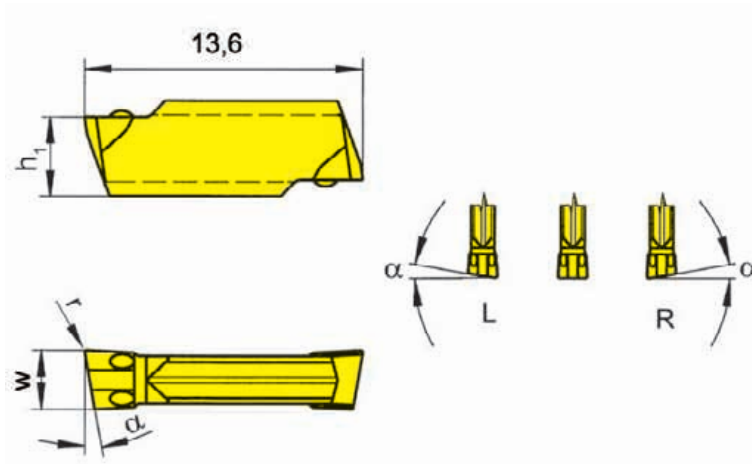

für Klemmhalter
for Toolholder

Typ H223
Type

R = rechts wie gezeichnet
R = right hand version shown

L = links spiegelbildlich
L = left hand version

Bestellnummer Part number	w	r	α	h ₁	Größe Size	TF45	TI25	TN35
S223.0020.C1	2,0	0,15	0°	3,65	01	▲	▲	▲
R/LS223.0420.C1	2,0	0,15	4°	3,65	01	▲/Δ	▲/Δ	▲/Δ
R/LS223.0820.C1	2,0	0,15	8°	3,65	01	▲/Δ	▲/Δ	▲/▲
R/LS223.1520.C1	2,0	0,15	15°	3,65	01	▲/Δ	▲/Δ	▲/Δ
S223.0025.C1	2,5	0,15	0°	3,75	02	Δ	▲	Δ
R/LS223.0425.C1	2,5	0,15	4°	3,75	02	Δ/Δ	Δ/Δ	Δ/Δ
R/LS223.0825.C1	2,5	0,15	8°	3,75	02	Δ/Δ	▲/Δ	Δ/Δ
S223.0030.C1	3,0	0,15	0°	3,95	03	▲	▲	▲
R/LS223.0430.C1	3,0	0,15	4°	3,95	03	Δ/Δ	Δ/Δ	Δ/Δ
R/LS223.0830.C1	3,0	0,15	8°	3,95	03	▲/Δ	▲/Δ	▲/Δ
						P	•	•
						M	•	•
						K	•	•
						N	•	•
						S	•	•
						H	-	-

▲ ab Lager / on stock Δ 4 Wochen / 4 weeks x auf Anfrage / upon request

● empfohlen / recommended

o bedingt einsetzbar / alternative recommendation

- nicht geeignet / not suitable

■ unbeschichtete HM-Sorten / uncoated grades

■ beschichtete HM-Sorten / coated grades

■ bestückt/Cermet / brazed/Cermet

Abmessungen in mm

Dimensions in mm

Ausführung R oder L angeben

State R or L version

Wendeschneidplatten sind in rechten und linken Klemmhaltern verwendbar.

Indexable inserts can be used in right and left hand toolholders.

HM-Sorten
Carbide grades

C



209



D

**Klemmhalter mit
Schneidplatten**

Stechbreite 2,0 - 3,0 mm

**Toolholder with
Inserts**

Width of groove 2,0 - 3,0 mm

Einstecken und Längsdrehen

Grooving and Side Turning

Klemmhalter
Toolholder
B209

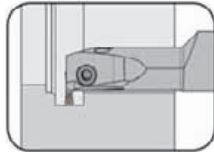

Seite/Page
D3

Wendeschneidplatte
Indexable insert
S209



Seite/Page
D4

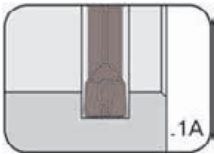

Seite/Page
D5

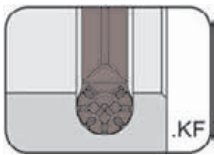

Seite/Page
D6

D

Einstecken und Längsdrehen (innen)

Grooving and Side Turning (internal)



Klemmhalter

Toolholder

B209

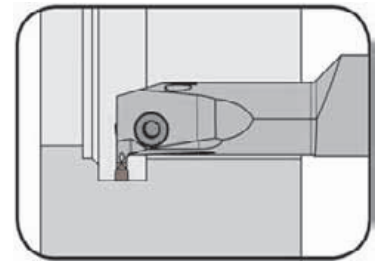

Bohrungs-Ø ab	Bore Ø from	16 mm
Stechtiefe bis	Depth of groove up to	5 mm
Spannbereich	Clamping range	3,0 mm

für Wendeschneidplatte
for Indexable insert

Typ S209
Type

D

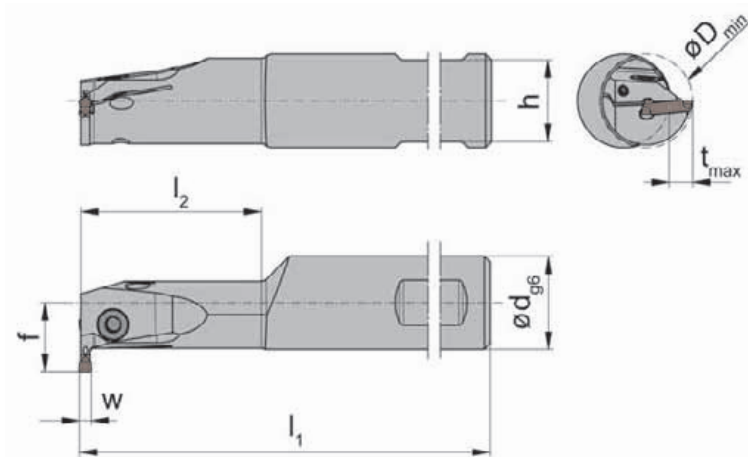

R = rechts wie gezeichnet
R = right hand version shown

L = links spiegelbildlich
L = left hand version

mit innerer
Kühlmittelzufuhr
with through coolant supply

Bestellnummer Part number	d	l ₁	l ₂	h	t _{max}	D _{min}	f	Größe Size	Spannbereich Clamping range
R/LB209.0016.1.02.IK	16	110	30	14	3,5	16	11,8	20	2,0-2,4
R/LB209.0020.1.12.IK	20	110	30	18	5,0	18	15,3	20	2,0-2,4
R/LB209.0016.1.025.IK	16	110	30	14	3,5	16	11,8	25	2,5-3,0
R/LB209.0020.1.125.IK	20	110	30	18	5,0	18	15,3	25	2,5-3,0
R/LB209.0016.1.03.IK	16	110	30	14	3,5	16	11,8	30	3,0-3,0
R/LB209.0020.1.13.IK	20	110	30	18	5,0	18	15,3	30	3,0-3,0

Ausführung R oder L angeben
State R or L version

w siehe WSP
w see indexable inserts

Abmessungen in mm
Dimensions in mm

Weitere Abmessungen auf Anfrage
Further sizes upon request

Das Anzugsdrehmoment der Schrauben finden Sie in den Technischen Hinweisen.
For torque specification of the screw, please see Technical Instructions.

Ersatzteile

Spare Parts

Klemmhalter Toolholder	Spannschraube Screw	TORX PLUS®-Schlüssel TORX PLUS® Wrench
R/LB209...	3.5.12T10EP	T10PL

Einstechen und Längsdrehen

Grooving and Side Turning



Wendeschneidplatte

Indexable insert

S209

mit Spanformung
with chip forming

Stechbreite	Width of groove	2-3 mm
-------------	-----------------	--------

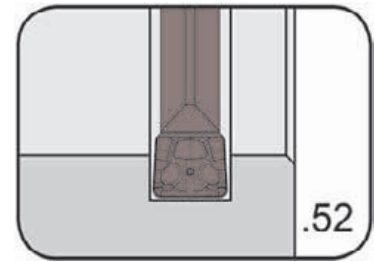

präzisionsgesintert
precision sintered

für Klemmhalter
for Toolholder

Typ B209
Type

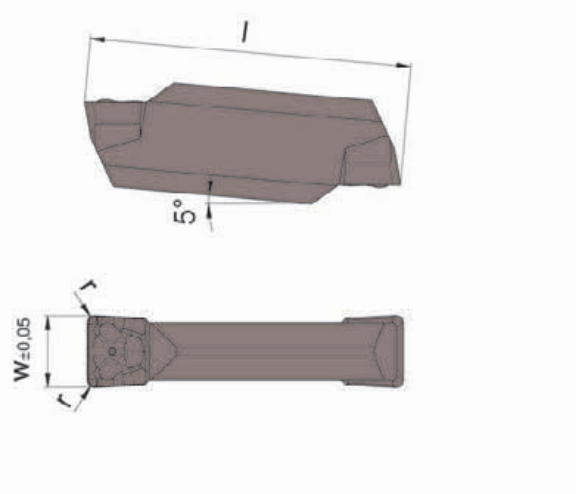

Wechselgenauigkeit
Länge ± 0,05 mm
Wechselgenauigkeit
Länge ± 0,05 mm

Bestellnummer Part number	w	r	l	Größe Size	AS45
S209.0200.52	2,0	0,2	9	20	▲
S209.0250.52	2,5	0,2	10	25	▲
S209.0300.52	3,0	0,2	10	30	▲

▲ ab Lager / on stock Δ 4 Wochen / 4 weeks x auf Anfrage / upon request

● empfohlen / recommended

o bedingt einsetzbar / alternative recommendation

- nicht geeignet / not suitable

■ unbeschichtete HM-Sorten / uncoated grades

■ beschichtete HM-Sorten / coated grades

■ bestückt/Cermet / brazed/Cermet

Abmessungen in mm

Dimensions in mm

Wendeschneidplatten sind in rechten und linken Klemmhaltern verwendbar.

Indexable inserts can be used in right and left hand toolholders.

HM-Sorten
Carbide grades

P	●
M	●
K	●
N	○
S	●
H	-

D

Einstechen und Längsdrehen

Grooving and Side Turning



Wendeschneidplatte

Indexable insert

S209

mit Spanformung
with chip forming

Stechbreite	Width of groove	2-3 mm
-------------	-----------------	--------

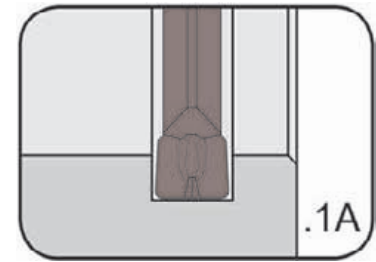

präzisionsgesintert
precision sintered

für Klemmhalter
for Toolholder

Typ B209
Type

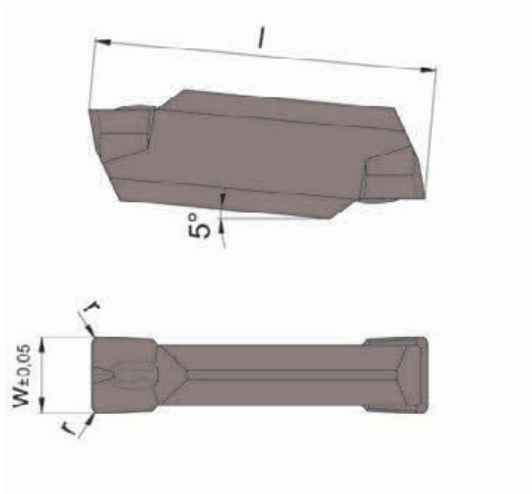

Wechselgenauigkeit
Länge ± 0,05 mm
Wechselgenauigkeit
Länge ± 0,05 mm

Bestellnummer Part number	w	r	l	Größe Size	AS45
S209.0200.1A2	2,0	0,2	9	20	▲
S209.0250.1A2	2,5	0,2	10	25	▲
S209.0300.1A2	3,0	0,2	10	30	▲

▲ ab Lager / on stock	Δ 4 Wochen / 4 weeks	x auf Anfrage / upon request
● empfohlen / recommended		
o bedingt einsetzbar / alternative recommendation		
- nicht geeignet / not suitable		
□ unbeschichtete HM-Sorten / uncoated grades		
■ beschichtete HM-Sorten / coated grades		
■ bestückt/Cermet / brazed/Cermet		

P	●
M	●
K	●
N	○
S	●
H	-

Abmessungen in mm
Dimensions in mm

HM-Sorten
Carbide grades

Wendeschneidplatten sind in rechten und linken Klemmhaltern verwendbar.
Indexable inserts can be used in right and left hand toolholders.



Einstechen und Längsdrehen

Grooving and Side Turning



Wendeschneidplatte

Indexable insert

S209

mit Spanformung
with chip forming

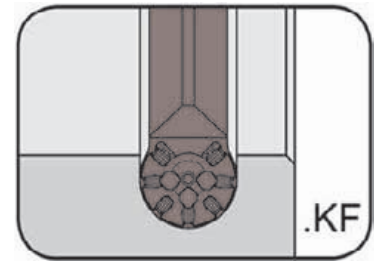

Stechbreite Vollradius	Width of groove Full radius	2-3 mm 1-1,5 mm
---------------------------	--------------------------------	--------------------

präzisionsgesintert
precision sintered

für Klemhalter
for Toolholder

Typ B209
Type

D

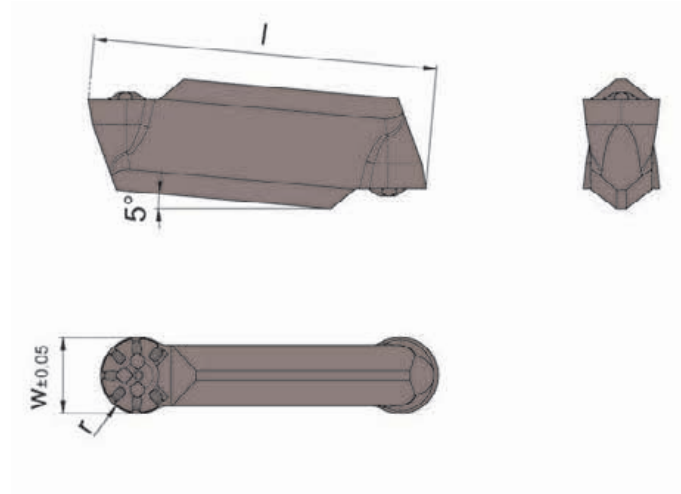

Wechselgenauigkeit
Länge $\pm 0,05$ mm
Wechselgenauigkeit
Länge $\pm 0,05$ mm

Bestellnummer Part number	w	l	r	Größe Size	AS45
S209.0010.KF2	2	9	1,0	20	▲
S209.0015.KF3	3	10	1,5	30	▲

- ▲ ab Lager / on stock Δ 4 Wochen / 4 weeks x auf Anfrage / upon request
- empfohlen / recommended
- o bedingt einsetzbar / alternative recommendation
- nicht geeignet / not suitable
- unbeschichtete HM-Sorten / uncoated grades
- beschichtete HM-Sorten / coated grades
- bestückt/Cermet / brazed/Cermet

P	●
M	●
K	●
N	○
S	●
H	-

Abmessungen in mm
Dimensions in mm

HM-Sorten
Carbide grades

Wendeschneidplatten sind in rechten und linken Klemmhaltern verwendbar.
Indexable inserts can be used in right and left hand toolholders.

216



**Klemmhalter mit
Schneidplatten**

Schneidbreite 2 - 6 mm

**Toolholder with
Inserts**

Width of groove 2 - 6 mm

Einstecken und Längsdrehen

Grooving and Side Turning

Klemmhalter
Toolholder
B216

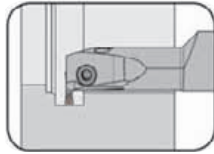

Seite/Page
E3

Wendeschneidplatte
Indexable insert
S216

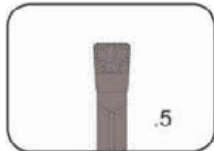

Seite/Page
E4



Seite/Page
E5

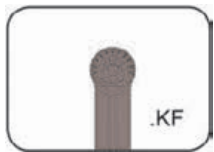

Seite/Page
E6

E

Einstecken und Längsdrehen (innen)

Grooving and Side Turning (internal)



Klemmhalter

Toolholder

B216

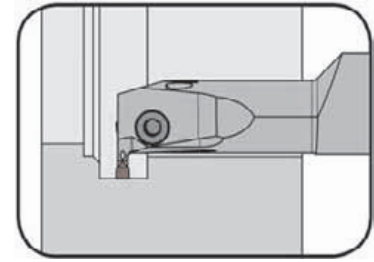

Bohrungs-Ø ab
Stechtiefe bis
Spannbereich

Bore Ø from
Depth of groove up to
Clamping range

20 mm
7,5 mm
2,0 - 6,1 mm

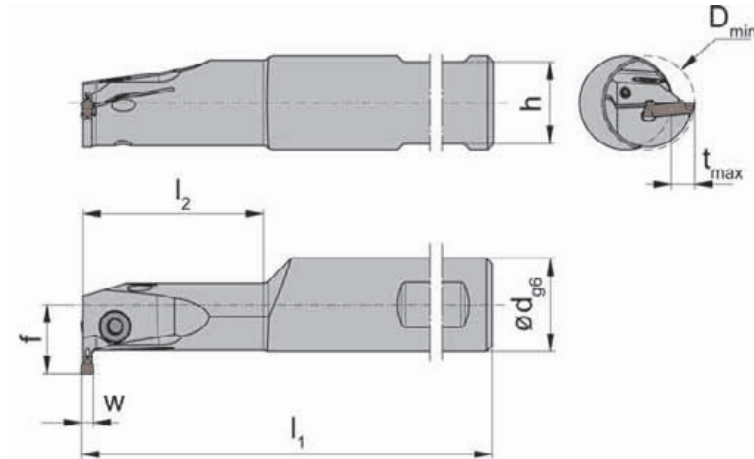

für Wendeschneidplatte
for Indexable insert

Typ S216
Type



mit innerer
Kühlmittelzufuhr
with through coolant supply

R = rechts wie gezeichnet
R = right hand version shown

L = links spiegelbildlich
L = left hand version

Bestellnummer Part number	d	l ₁	h	t _{max}	l ₂	D _{min}	f	Größe Size	Spannbereich Clamping range
R/LB216.0020.1.22.IK	20	110	18	6,0	30	20	16,3	20	2,0-2,4
R/LB216.0020.1.225.IK	20	110	18	6,0	30	20	16,3	25	2,4-2,8
R/LB216.0020.1.23.IK	20	110	18	6,0	30	20	16,3	30	2,8-3,7
R/LB216.0020.1.24.IK	20	110	18	6,0	30	20	16,3	40	3,7-4,4
R/LB216.0025.2.22.IK	25	150	23	7,5	50	25	20,3	20	2,0-2,4
R/LB216.0025.2.225.IK	25	150	23	7,5	50	25	20,3	25	2,4-2,8
R/LB216.0025.2.23.IK	25	150	23	7,5	50	25	20,3	30	2,8-3,7
R/LB216.0025.2.24.IK	25	150	23	7,5	50	25	20,3	40	3,7-4,4
R/LB216.0025.23.1.22.IK	25	150	23	7,0	30	23	19,8	20	2,0-2,4
R/LB216.0025.23.1.225.IK	25	150	23	7,0	30	23	19,8	25	2,4-2,8
R/LB216.0025.23.1.23.IK	25	150	23	7,0	30	23	19,8	30	2,8-3,7
R/LB216.0025.23.1.24.IK	25	150	23	7,0	30	23	19,8	40	3,7-4,4
R/LB216.0025.23.1.25.IK	25	150	23	7,0	30	23	19,8	50	4,4-5,1
R/LB216.0025.23.1.26.IK	25	150	23	7,0	30	23	19,8	60	5,1-6,1

Ausführung R oder L angeben
State R or L version

w siehe WSP
w see indexable inserts

Abmessungen in mm
Dimensions in mm

Weitere Abmessungen auf Anfrage
Further sizes upon request

Das Anzugsdrehmoment der Schrauben finden Sie in den Technischen Hinweisen.
For torque specification of the screw, please see Technical Instructions.

Ersatzteile

Spare Parts

Klemmhalter Toolholder	Spannschraube Screw	TORX PLUS®-Schlüssel TORX PLUS® Wrench
R/LB216.0020.1.2..IK	3.5.12T10EP	T10PL
R/LB216.0020.2..IK	5.13T20EP	T20PQ

Einstecken und Längsdrehen

Grooving and Side Turning



Wendeschneidplatte

Indexable insert

S216

mit Spanformung
with chip forming

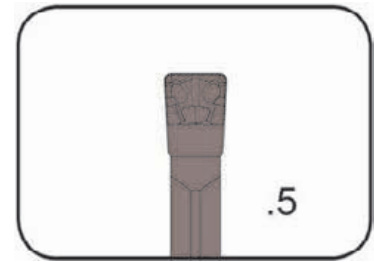

Stechbreite	Width of groove	2-6 mm
-------------	-----------------	--------

präzisionsgesintert
precision sintered

für Klemhalter
for Toolholder

Typ B216
Type

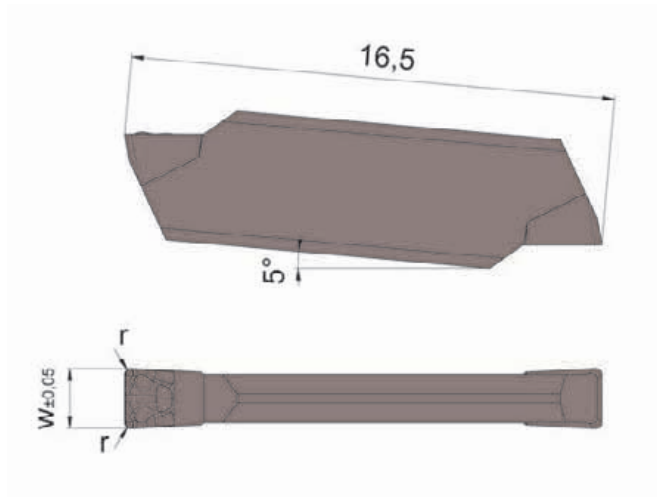

Wechselgenauigkeit
Länge ± 0,1 mm
Indexability length ± 0,1 mm

Bestellnummer Part number	w	r	Größe Size	AS45
S216.0200.52	2,0	0,2	20	▲
S216.0250.52	2,5	0,2	25	▲
S216.0300.52	3,0	0,2	30	▲
S216.0400.52	4,0	0,2	40	▲
S216.0500.54	5,0	0,4	50	▲
S216.0600.54	6,0	0,4	60	▲

▲ ab Lager / on stock Δ 4 Wochen / 4 weeks x auf Anfrage / upon request

● empfohlen / recommended

o bedingt einsetzbar / alternative recommendation

- nicht geeignet / not suitable

■ unbeschichtete HM-Sorten / uncoated grades

■ beschichtete HM-Sorten / coated grades

■ bestückt/Cermet / brazed/Cermet

Abmessungen in mm

Dimensions in mm

Wendeschneidplatten sind in rechten und linken Klemmaltern verwendbar.

Indexable inserts can be used in right and left hand toolholders.

P	●
M	●
K	●
N	○
S	●
H	-

HM-Sorten
Carbide grades

E

Einstecken und Längsdrehen

Grooving and Side Turning



Wendeschneidplatte

Indexable insert

S216

mit Spanformung
with chip forming

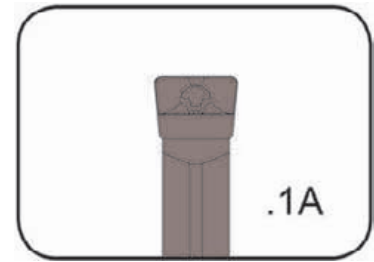

Stechbreite	Width of groove	2-6 mm
-------------	-----------------	--------

präzisionsgesintert
precision sintered

für Klemmhalter
for Toolholder

Typ B216
Type

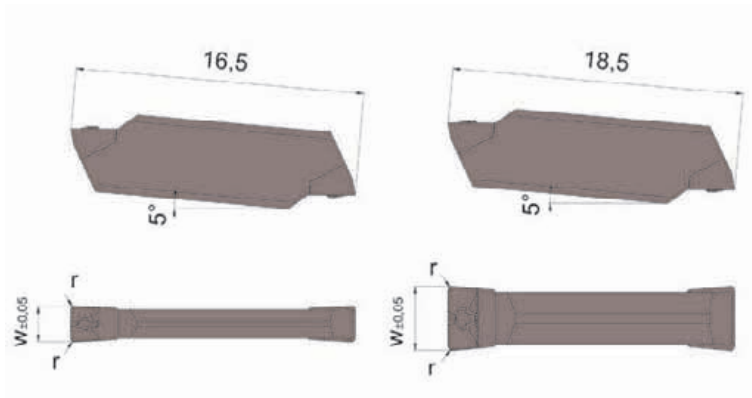

Schneidbreite 2,0 - 4,0 mm
Width 2,0 - 4,0 mm

Schneidbreite 5,0 - 6,0 mm
Width 5,0 - 6,0 mm

Wechselgenauigkeit
Länge ± 0,1 mm
Indexability length ± 0,1 mm

Bestellnummer Part number	w	r	Größe Size	AS45
S216.0200.1A2	2,0	0,2	20	▲
S216.0250.1A2	2,5	0,2	25	▲
S216.0300.1A2	3,0	0,2	30	▲
S216.0400.1A2	4,0	0,2	40	▲
S216.0500.1A4	5,0	0,4	50	▲
S216.0600.1A4	6,0	0,4	60	▲

▲ ab Lager / on stock Δ 4 Wochen / 4 weeks x auf Anfrage / upon request

● empfohlen / recommended

o bedingt einsetzbar / alternative recommendation

- nicht geeignet / not suitable

■ unbeschichtete HM-Sorten / uncoated grades

■ beschichtete HM-Sorten / coated grades

■ bestückt/Cermet / brazed/Cermet

Abmessungen in mm

Dimensions in mm

Wendeschneidplatten sind in rechten und linken Klemmhaltern verwendbar.

Indexable inserts can be used in right and left hand toolholders.

P	●
M	●
K	●
N	○
S	●
H	-

HM-Sorten
Carbide grades



Einstecken und Längsdrehen

Grooving and Side Turning



Wendeschneidplatte

Indexable insert

S216

mit Spanformung
with chip forming

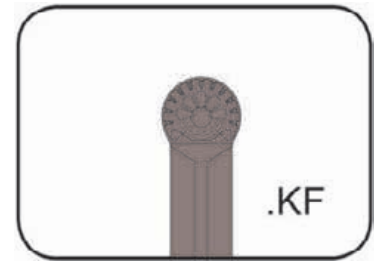

Stechbreite Vollradius	Width of groove Full radius	2-4 mm 1-2 mm
---------------------------	--------------------------------	------------------

präzisionsgesintert
precision sintered

für Klemmhalter
for Toolholder

Typ B216
Type

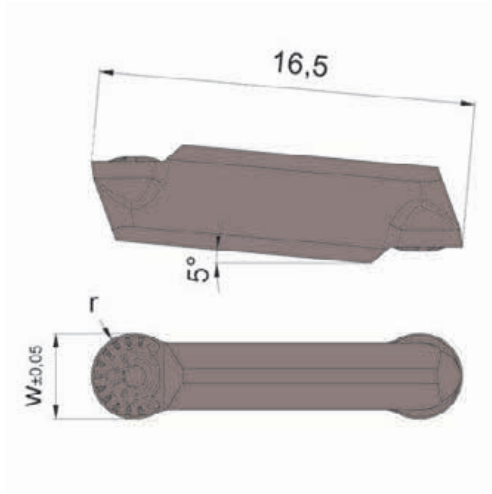

Wechselgenauigkeit
Länge ± 0,1 mm
Indexability length ± 0,1 mm

E

Bestellnummer Part number	w	r	Größe Size	AS45
S216.0010.KF2	2	1,0	20	▲
S216.0015.KF3	3	1,5	30	▲
S216.0020.KF4	4	2,0	40	▲

▲ ab Lager / on stock Δ 4 Wochen / 4 weeks x auf Anfrage / upon request

● empfohlen / recommended

o bedingt einsetzbar / alternative recommendation

- nicht geeignet / not suitable

■ unbeschichtete HM-Sorten / uncoated grades

■ beschichtete HM-Sorten / coated grades

■ bestückt/Cermet / brazed/Cermet

Abmessungen in mm

Dimensions in mm

Wendeschneidplatten sind in rechten und linken Klemmhaltern verwendbar.

Indexable inserts can be used in right and left hand toolholders.

P	●
M	●
K	●
N	○
S	●
H	-

HM-Sorten
Carbide grades

217



**Klemmhalter mit
Schneidplatten**

Stechbreite 0,5 - 5,3 mm

**Toolholder with
Inserts**

Width of groove 0,5 - 5,3 mm

Einstecken (außen)

Grooving (external)



Klemmhalter
Toolholder
240/248/230/233/
234/235/245

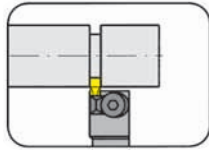

Seite/Page
F3-F5

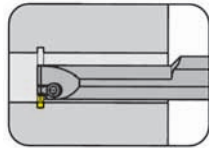

Seite/Page
F6

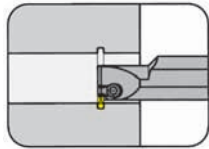

Seite/Page
F7

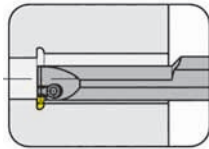

Seite/Page
F8

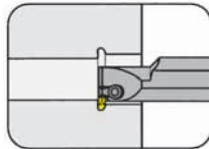

Seite/Page
F9

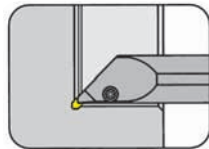

Seite/Page
F10

Wendeschneidplatte
Indexable insert
217

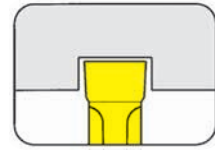

Seite/Page
F11

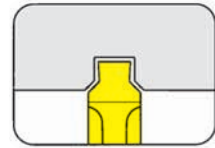

Seite/Page
F12

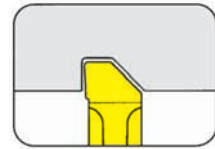

Seite/Page
F13



Seite/Page
F15

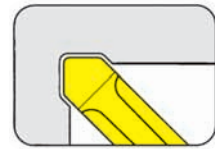

Seite/Page
F14

Kurzklammhalter
Cartridge
232

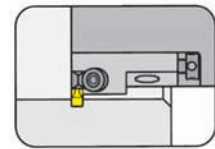

Seite/Page
F16

F

Einstechen (außen)

Grooving (external)



Klemmhalter

Toolholder

240

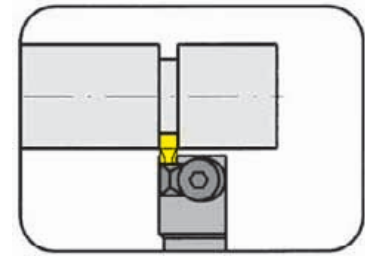

Stechtiefe bis
Spannbereich

Depth of groove up to
Clamping range

4 mm
0,5 - 2,7 mm

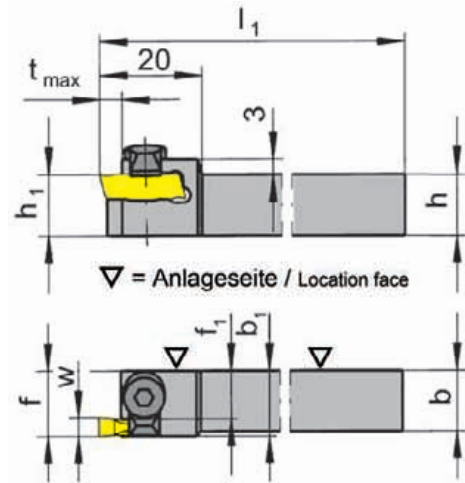

für Wendeschneidplatte
for Indexable insert

Typ 217
Type



R = rechts wie gezeichnet
R = right hand version shown

L = links spiegelbildlich
L = left hand version

Bestellnummer Part number	h	b	l ₁	h ₁	f	t _{max}	f ₁	b ₁	Größe Size	Spannbereich Clamping range
R/L240.1010.01	10	10	80	10	f ₁ +w-a ₁	4	11,5	13	01	0,5-1,7
R/L240.1212.01	12	12	100	12	f ₁ +w-a ₁	4	11,5	13	01	0,5-1,7
R/L240.1414.01	14	14	100	14	f ₁ +w-a ₁	4	12,5	14	01	0,5-1,7
R/L240.1616.01	16	16	125	16	f ₁ +w-a ₁	4	14,5	16	01	0,5-1,7
R/L240.2020.01	20	20	125	20	f ₁ +w-a ₁	4	18,5	20	01	0,5-1,7
R/L240.1010.02	10	10	80	10	f ₁ +w-a ₁	4	10,5	13	02	1,7-2,7
R/L240.1212.02	12	12	100	12	f ₁ +w-a ₁	4	10,5	13	02	1,7-2,7
R/L240.1414.02	14	14	100	14	f ₁ +w-a ₁	4	11,5	14	02	1,7-2,7
R/L240.1616.02	16	16	125	16	f ₁ +w-a ₁	4	13,5	16	02	1,7-2,7
R/L240.2020.02	20	20	125	20	f ₁ +w-a ₁	4	17,5	20	02	1,7-2,7

Ausführung R oder L angeben
State R or L version

w, a₁ siehe WSP
w, a₁ see indexable inserts

Abmessungen in mm
Dimensions in mm

Weitere Abmessungen auf Anfrage
Further sizes upon request

Das Anzugsdrehmoment der Schrauben finden Sie in den Technischen Hinweisen.
For torque specification of the screw, please see Technical Instructions.

Ersatzteile

Spare Parts

Klemmhalter Toolholder	Inbus-Schlüssel Wrench	Spannelement Clamping element
R/L240...	SW2,5 DIN911	8.3

Einstechen (außen)

Grooving (external)



Klemmhalter

Toolholder

240

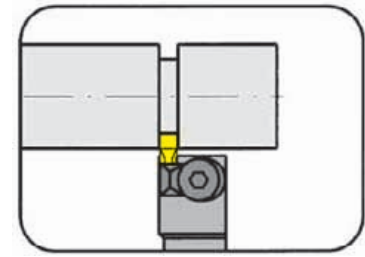

Stechtiefe bis
Spannbereich

Depth of groove up to
Clamping range

4 mm
2,7 - 5,3 mm

für Wendeschneidplatte
for Indexable insert

Typ 217
Type

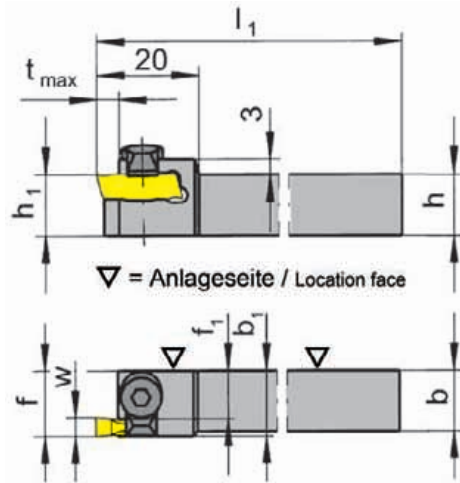

R = rechts wie gezeichnet
R = right hand version shown

L = links spiegelbildlich
L = left hand version

Bestellnummer Part number	h	b	l ₁	h ₁	f	t _{max}	f ₁	b ₁	Größe Size	Spannbereich Clamping range
R/L240.1010.03	10	10	80	10	f ₁ +w-a ₁	4	9,5	13	03	2,7-3,7
R/L240.1212.03	12	12	100	12	f ₁ +w-a ₁	4	9,5	13	03	2,7-3,7
R/L240.1414.03	14	14	100	14	f ₁ +w-a ₁	4	10,5	14	03	2,7-3,7
R/L240.1616.03	16	16	125	16	f ₁ +w-a ₁	4	12,5	16	03	2,7-3,7
R/L240.2020.03	20	20	125	20	f ₁ +w-a ₁	4	16,5	20	03	2,7-3,7
R/L240.1010.04	10	10	80	10	f ₁ +w-a ₁	4	9,8	15	04	3,7-5,3
R/L240.1212.04	12	12	100	12	f ₁ +w-a ₁	4	9,8	15	04	3,7-5,3
R/L240.1414.04	14	14	100	14	f ₁ +w-a ₁	4	9,8	15	04	3,7-5,3
R/L240.1616.04	16	16	125	16	f ₁ +w-a ₁	4	10,8	16	04	3,7-5,3
R/L240.2020.04	20	20	125	20	f ₁ +w-a ₁	4	14,8	20	04	3,7-5,3

Ausführung R oder L angeben
State R or L version

w, a₁ siehe WSP
w, a₁ see indexable inserts

Abmessungen in mm
Dimensions in mm

Weitere Abmessungen auf Anfrage
Further sizes upon request

Das Anzugsdrehmoment der Schrauben finden Sie in den Technischen Hinweisen.
For torque specification of the screw, please see Technical Instructions.

Ersatzteile

Spare Parts

Klemmhalter Toolholder	Inbus-Schlüssel Wrench	Spannelement Clamping element
R/L240...03	SW2,5 DIN911	8.3
R/L240...04	SW2,5 DIN911	8.4

Einstecken (außen)

Grooving (external)



Klemmhalter

Toolholder

248

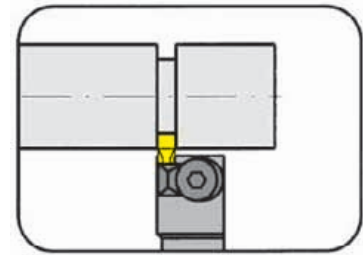

Stechtiefe bis Spannbereich	Depth of groove up to Clamping range	4 mm 0,5 - 2,7 mm
--------------------------------	---	----------------------

für Wendeschneidplatte
for Indexable insert

Typ 217
Type

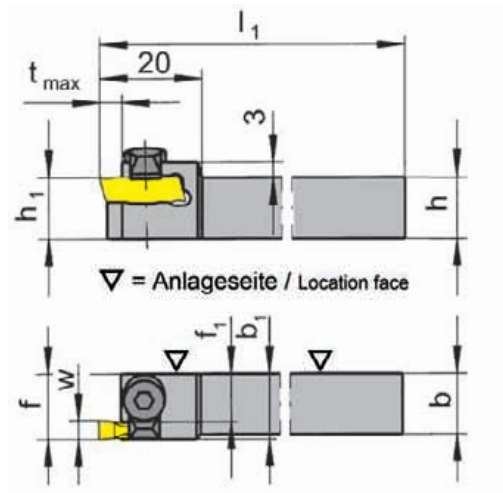

R = rechts wie gezeichnet
R = right hand version shown

L = links spiegelbildlich
L = left hand version

Bestellnummer Part number	h	b	l ₁	h ₁	f	t _{max}	f ₁	b ₁	Größe Size	Spannbereich Clamping range
R/L248.1212.01	12	12	95	12	f ₁ +a ₁	4	1,5	13	01	0,5-1,7
R/L248.1212.02	12	12	95	12	f ₁ +a ₁	4	2,5	13	02	1,7-2,7

Ausführung R oder L angeben
State R or L version

w, a₁ siehe WSP
w, a₁ see indexable inserts

Abmessungen in mm
Dimensions in mm

Weitere Abmessungen auf Anfrage
Further sizes upon request

Das Anzugsdrehmoment der Schrauben finden Sie in den Technischen Hinweisen.
For torque specification of the screw, please see Technical Instructions.

Ersatzteile

Spare Parts

Klemmhalter Toolholder	Inbus-Schlüssel Wrench	Spannelement Clamping element
R/L248...	SW2,5 DIN911	8.3

F

Einstecken (innen)

Grooving (internal)



Klemmhalter

Toolholder

230/250

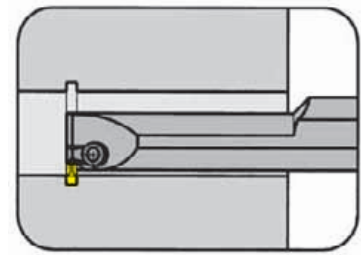

Bohrungs-Ø ab
Stechtiefe bis
Spannbereich

Bore Ø from
Depth of groove up to
Clamping range

20 mm
4,7 mm
0,9 - 5,3 mm

für Wendeschneidplatte
for Indexable insert

Typ 217
Type

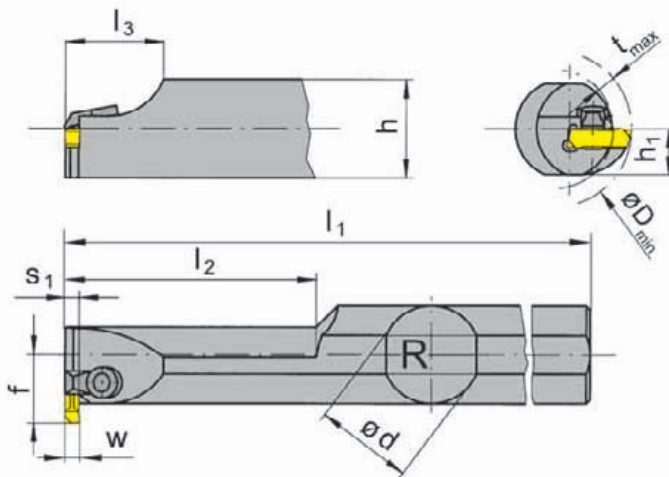

R = rechts wie gezeichnet
R = right hand version shown

L = links spiegelbildlich
L = left hand version

lange Ausführung
long style

Bestellnummer Part number	d	l ₁	l ₃	h	s ₁	h ₁	t _{max}	l ₂	D _{min}	f	Größe Size	Spannbereich Clamping range
R/L230.0020.01	20	180	18	18	1,5	9,0	3,0	60	20	13,3	01	0,9-1,7
R/L250.0025.01	25	250	25	23	1,5	11,5	4,7	80	25	17,5	01	0,9-1,7
R/L250.0032.01	32	250	25	30	1,5	15,0	4,7	80	32	21,0	01	0,9-1,7
R/L230.0020.02	20	180	18	18	2,5	9,0	3,0	60	20	13,3	02	1,7-2,7
R/L250.0025.02	25	250	25	23	2,5	11,5	4,7	80	25	17,5	02	1,7-2,7
R/L250.0032.02	32	250	25	30	2,5	15,0	4,7	80	32	21,0	02	1,7-2,7
R/L230.0020.03	20	180	18	18	3,5	9,0	3,0	60	20	13,3	03	2,7-3,7
R/L250.0025.03	25	250	25	23	3,5	11,5	4,7	80	25	17,5	03	2,7-3,7
R/L250.0032.03	32	250	25	30	3,5	15,0	4,7	80	32	21,0	03	2,7-3,7
R/L230.0020.04	20	180	18	18	5,2	9,0	3,0	60	20	13,3	04	3,7-5,3
R/L250.0025.04	25	250	25	23	5,2	11,5	4,7	80	25	17,5	04	3,7-5,3
R/L250.0032.04	32	250	25	30	5,2	15,0	4,7	80	32	21,0	04	3,7-5,3

Ausführung R oder L angeben
State R or L version

w siehe WSP
w see indexable inserts

Abmessungen in mm
Dimensions in mm

Weitere Abmessungen auf Anfrage
Further sizes upon request

Das Anzugsdrehmoment der Schrauben finden Sie in den Technischen Hinweisen.
For torque specification of the screw, please see Technical Instructions.

Ersatzteile

Spare Parts

Klemmhalter Toolholder	Inbus-Schlüssel Wrench	Spannelement Clamping element
R/L...01/02/03	SW2,5 DIN911	8.3
R/L...04	SW2,5 DIN911	8.4

Einstecken (innen)

Grooving (internal)



Klemmhalter

Toolholder

233/253

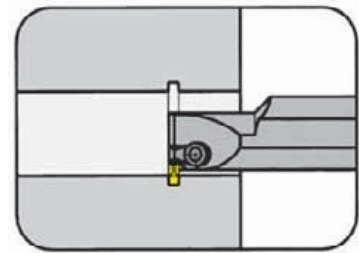

Bohrungs-Ø ab
Stechtiefe bis
Spannbereich

Bore Ø from
Depth of groove up to
Clamping range

20 mm
4,7 mm
0,9 - 5,3 mm

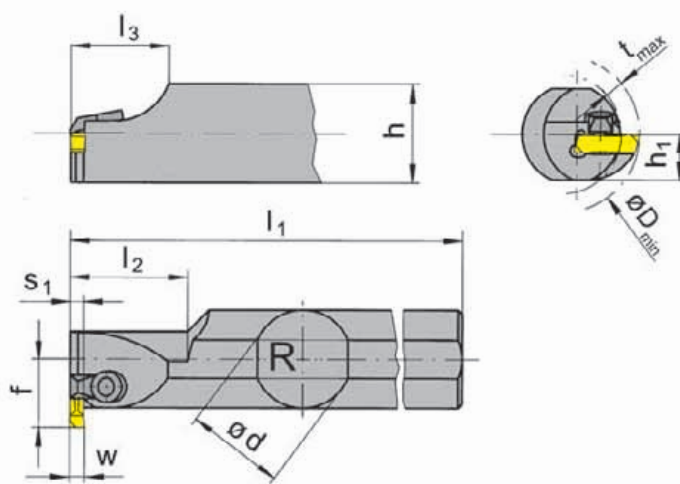

für Wendeschneidplatte
for Indexable insert

Typ 217
Type

F

kurze Ausführung
short style

R = rechts wie gezeichnet
R = right hand version shown

L = links spiegelbildlich
L = left hand version

Bestellnummer Part number	d	l ₁	l ₃	h	s ₁	h ₁	t _{max}	l ₂	D _{min}	f	Größe Size	Spannbereich Clamping range
R/L233.0020.01	20	130	18	18	1,5	9,0	3,0	25	20	13,3	01	0,9-1,7
R/L253.0025.01	25	150	25	23	1,5	11,5	4,7	30	25	17,5	01	0,9-1,7
R/L253.0032.01	32	150	25	30	1,5	15,0	4,7	30	32	21,0	01	0,9-1,7
R/L233.0020.02	20	130	18	18	2,5	9,0	3,0	25	20	13,3	02	1,7-2,7
R/L253.0025.02	25	150	25	23	2,5	11,5	4,7	30	25	17,5	02	1,7-2,7
R/L253.0032.02	32	150	25	30	2,5	15,0	4,7	30	32	21,0	02	1,7-2,7
R/L233.0020.03	20	130	18	18	3,5	9,0	3,0	25	20	13,3	03	2,7-3,7
R/L253.0025.03	25	150	25	23	3,5	11,5	4,7	30	25	17,5	03	2,7-3,7
R/L253.0032.03	32	150	25	30	3,5	15,0	4,7	30	32	21,0	03	2,7-3,7
R/L233.0020.04	20	130	18	18	5,2	9,0	3,0	25	20	13,3	04	3,7-5,3
R/L253.0025.04	25	150	25	23	5,2	11,5	4,7	30	25	17,5	04	3,7-5,3
R/L253.0032.04	32	150	25	30	5,2	15,0	4,7	30	32	21,0	04	3,7-5,3

Ausführung R oder L angeben
State R or L version

w siehe WSP
w see indexable inserts

Abmessungen in mm
Dimensions in mm

Weitere Abmessungen auf Anfrage
Further sizes upon request

Das Anzugsdrehmoment der Schrauben finden Sie in den Technischen Hinweisen.
For torque specification of the screw, please see Technical Instructions.

Ersatzteile

Spare Parts

Klemmhalter Toolholder	Inbus-Schlüssel Wrench	Spannelement Clamping element
R/L...01/02/03	SW2,5 DIN911	8.3
R/L...04	SW2,5 DIN911	8.4

Einstechen (innen)

Grooving (internal)



Klemmhalter

Toolholder

234/254

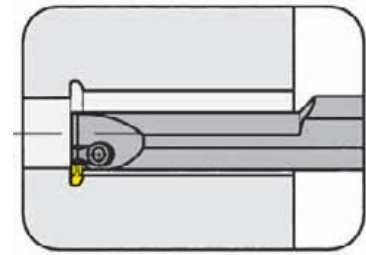

Bohrungs-Ø ab	Bore Ø from	20 mm
Stechtiefe bis	Depth of groove up to	4,7 mm
Spannbereich	Clamping range	0,9 - 5,3 mm

für Wendeschneidplatte
for Indexable insert

Typ 217
Type

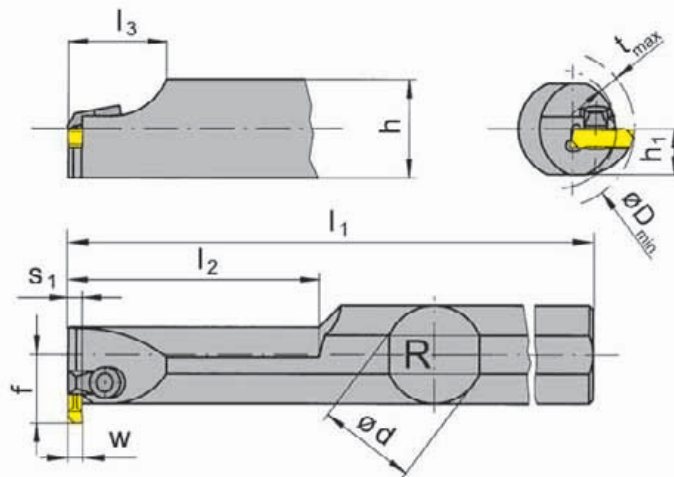

R = rechts wie gezeichnet
R = right hand version shown

L = links spiegelbildlich
L = left hand version

lange Ausführung für
Formplatten
long style for special insert
shapes

Bestellnummer Part number	d	l ₁	l ₃	h	s ₁	h ₁	t _{max}	l ₂	D _{min}	f	Größe Size	Spannbereich Clamping range
R/L234.0020.01	20	180	18	18	1,5	9,0	3,0	60	20	13,3	01	0,9-1,7
R/L254.0025.01	25	250	25	23	1,5	11,5	4,7	80	25	17,5	01	0,9-1,7
R/L254.0032.01	32	250	25	30	1,5	15,0	4,7	80	32	21,0	01	0,9-1,7
R/L234.0020.02	20	180	18	18	2,5	9,0	3,0	60	20	13,3	02	1,7-2,7
R/L254.0025.02	25	250	25	23	2,5	11,5	4,7	80	25	17,5	02	1,7-2,7
R/L254.0032.02	32	250	25	30	2,5	15,0	4,7	80	32	21,0	02	1,7-2,7
R/L234.0020.03	20	180	18	18	3,5	9,0	3,0	60	20	13,3	03	2,7-3,7
R/L254.0025.03	25	250	25	23	3,5	11,5	4,7	80	25	17,5	03	2,7-3,7
R/L254.0032.03	32	250	25	30	3,5	15,0	4,7	80	32	21,0	03	2,7-3,7
R/L234.0020.04	20	180	18	18	5,2	9,0	3,0	60	20	13,3	04	3,7-5,3
R/L254.0025.04	25	250	25	23	5,2	11,5	4,7	80	25	17,5	04	3,7-5,3
R/L254.0032.04	32	250	25	30	5,2	15,0	4,7	80	32	21,0	04	3,7-5,3

Ausführung R oder L angeben
State R or L version

w siehe WSP
w see indexable inserts

Abmessungen in mm
Dimensions in mm

Weitere Abmessungen auf Anfrage
Further sizes upon request

Das Anzugsdrehmoment der Schrauben finden Sie in den Technischen Hinweisen.
For torque specification of the screw, please see Technical Instructions.

Ersatzteile

Spare Parts

Klemmhalter Toolholder	Inbus-Schlüssel Wrench	Spannelement Clamping element
R/L...01/02/03	SW2,5 DIN911	8.3
R/L...04	SW2,5 DIN911	8.4

Einstecken (innen)

Grooving (internal)



Klemmhalter

Toolholder

235/255

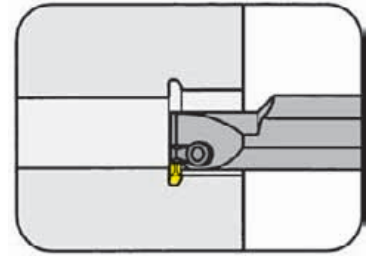

Bohrungs-Ø ab
Stechtiefe bis
Spannbereich

Bore Ø from
Depth of groove up to
Clamping range

20 mm
4,7 mm
0,9 - 5,3 mm

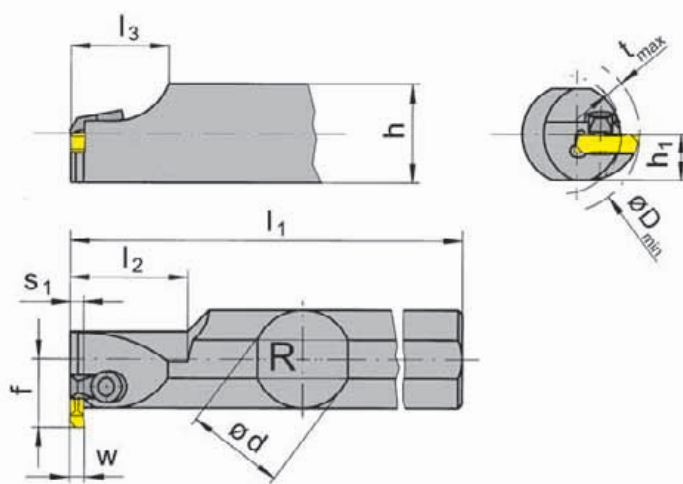

für Wendeschneidplatte
for Indexable insert

Typ 217
Type



R = rechts wie gezeichnet
R = right hand version shown

L = links spiegelbildlich
L = left hand version

kurze Ausführung für
Formplatten
short style for special insert
shapes

Bestellnummer Part number	d	l ₁	l ₃	h	s ₁	h ₁	t _{max}	l ₂	D _{min}	f	Größe Size	Spannbereich Clamping range
R/L235.0020.01	20	130	18	18	1,5	9,0	3,0	25	20	13,3	01	0,9-1,7
R/L255.0025.01	25	150	25	23	1,5	11,5	4,7	30	25	17,5	01	0,9-1,7
R/L255.0032.01	32	150	25	30	1,5	15,0	4,7	30	32	21,0	01	0,9-1,7
R/L235.0020.02	20	130	18	18	2,5	9,0	3,0	25	20	13,3	02	1,7-2,7
R/L255.0025.02	25	150	25	23	2,5	11,5	4,7	30	25	17,5	02	1,7-2,7
R/L255.0032.02	32	150	25	30	2,5	15,0	4,7	30	32	21,0	02	1,7-2,7
R/L235.0020.03	20	130	18	18	3,5	9,0	3,0	25	20	13,3	03	2,7-3,7
R/L255.0025.03	25	150	25	23	3,5	11,5	4,7	30	25	17,5	03	2,7-3,7
R/L255.0032.03	32	150	25	30	3,5	15,0	4,7	30	32	21,0	03	2,7-3,7
R/L235.0020.04	20	130	18	18	5,2	9,0	3,0	25	20	13,3	04	3,7-5,3
R/L255.0025.04	25	150	25	23	5,2	11,5	4,7	30	25	17,5	04	3,7-5,3
R/L255.0032.04	32	150	25	30	5,2	15,0	4,7	30	32	21,0	04	3,7-5,3

Ausführung R oder L angeben
State R or L version

w siehe WSP
w see indexable inserts

Abmessungen in mm
Dimensions in mm

Weitere Abmessungen auf Anfrage
Further sizes upon request

Das Anzugsdrehmoment der Schrauben finden Sie in den Technischen Hinweisen.
For torque specification of the screw, please see Technical Instructions.

Ersatzteile

Spare Parts

Klemmhalter Toolholder	Inbus-Schlüssel Wrench	Spannelement Clamping element
R/L...01/02/03	SW2,5 DIN911	8.3
R/L...04	SW2,5 DIN911	8.4

F

Eckenfreistechen (innen)

Grooving Corner Reliefs (internal)



Klemmhalter
Toolholder

245

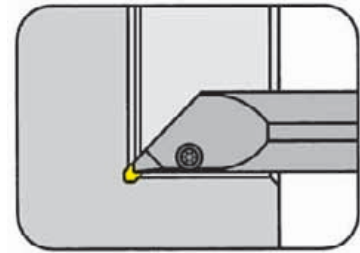

Bohrungs-Ø ab Bore Ø from 20 mm

für Wendeschneidplatte
for Indexable insert

Typ 217
Type

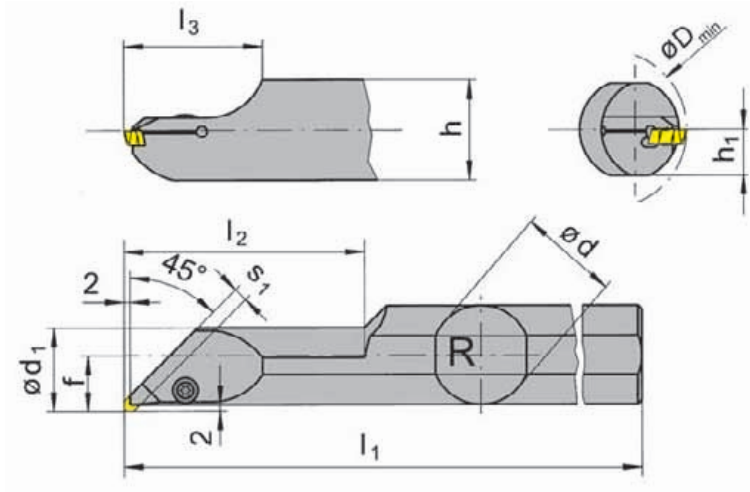

R = rechts wie gezeichnet
R = right hand version shown

L = links spiegelbildlich
L = left hand version

ähnlich DIN 509 Form „F“
similar to DIN 509 form „F“

Bestellnummer Part number	d	l ₁	l ₂	h	h ₁	f	D _{min}	d ₁	s ₁	l ₃	Größe Size	Spannbereich Clamping range
R/L245.0020.02	20	180	60,43	18	9	12	20	17,2	2,5	35,60	02	1,7-2,7
R/L245.0032.02	32	250	80,00	30	15	18	31	28,2	2,5	41,60	02	1,7-2,7
R/L245.0020.03	20	180	60,00	18	9	12	20	17,2	3,5	35,00	03	2,7-3,7
R/L245.0032.03	32	250	80,64	30	15	18	31	28,2	3,5	41,82	03	2,7-3,7
R/L245.0020.04	20	180	60,99	18	9	12	20	17,2	5,2	36,17	04	3,7-5,3
R/L245.0032.04	32	250	80,99	30	15	18	31	28,2	5,2	42,17	04	3,7-5,3

Ausführung R oder L angeben
State R or L version

Abmessungen in mm
Dimensions in mm

Weitere Abmessungen auf Anfrage
Further sizes upon request

Das Anzugsdrehmoment der Schrauben finden Sie in den Technischen Hinweisen.
For torque specification of the screw, please see Technical Instructions.

Ersatzteile
Spare Parts

Klemmhalter Toolholder	Spannschraube Screw	TORX PLUS®-Schlüssel TORX PLUS® Wrench
R/L245...	51.27.984P	T15PQ

Einstechen (außen und innen)

Grooving (external and internal)



Wendeschneidplatte

217

Indexable insert

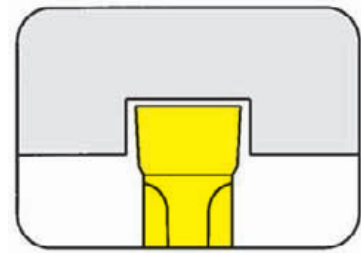

Seegerringnuten
Nuttennbreite Nw

Circlip grooves
Width of circlip Nw

DIN 471/472
0,5-5,15 mm

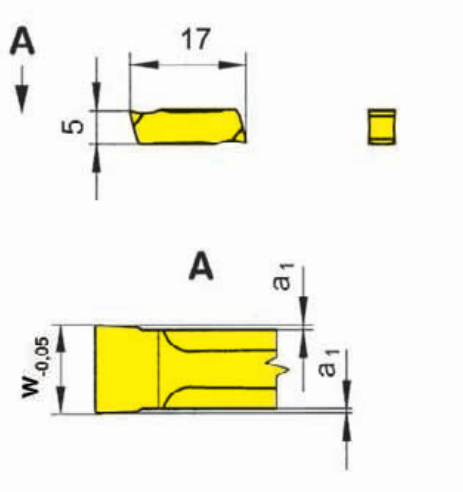

für Klemmhalter
for Toolholder

Typ 230
Type 232
233
240
248
250
253

Wechselgenauigkeit
Länge ± 0,02 mm
Indexability length ± 0,02 mm

F

Bestellnummer Part number	w	Nw	a ₁	Größe Size	K10	MG12	H20	P20	TC92	TN32	TN35
217.0050.00	0,57	0,50	0,06	01	▲			▲		▲	
217.0060.00	0,67	0,60	0,06	01	▲			▲		▲	
217.0070.00	0,77	0,70	0,06	01	▲			▲		▲	
217.0080.00	0,87	0,80	0,06	01	▲			▲		▲	
217.0090.00	0,97	0,90	0,06	01	▲			▲		▲	
217.0100.00	1,07	1,00	0,06	01	▲			▲		▲	
217.0110.00	1,24	1,10	0,10	01	▲			▲		▲	
217.0130.00	1,44	1,30	0,10	01	▲			▲		▲	
217.0160.00	1,74	1,60	0,10	01	▲			▲	▲	▲	▲
217.0185.00	1,99	1,85	0,10	02	▲	Δ	▲	▲	▲	▲	▲
217.0215.00	2,29	2,15	0,10	02	▲			▲	▲	▲	▲
217.0265.00	2,79	2,65	0,10	02	▲			▲	▲	▲	▲
217.0315.00	3,29	3,15	0,10	03	▲			▲	▲	▲	▲
217.0415.00	4,29	4,15	0,10	04	▲			▲	▲	▲	▲
217.0515.00	5,29	5,15	0,10	04	▲			▲	▲	▲	▲

- ▲ ab Lager / on stock Δ 4 Wochen / 4 weeks x auf Anfrage / upon request
- empfohlen / recommended
- o bedingt einsetzbar / alternative recommendation
- nicht geeignet / not suitable
- unbeschichtete HM-Sorten / uncoated grades
- beschichtete HM-Sorten / coated grades
- bestückt/Cermet / brazed/Cermet

P	●	○	●	●	●	●	●
M	○	●	○	-	-	-	●
K	●	●	-	-	-	-	●
N	●	●	-	-	-	-	●
S	○	●	-	-	-	-	●
H	-	-	-	-	-	-	-

Schneidplatten sind in **rechten und linken** Klemmhaltern verwendbar.
Indexable inserts can be used in **right and left** hand toolholders.

Max. Stechtiefen nur bei Breiten ≥ 1,1 mm erreichbar

Schmalere Schneidplatten sind in der Stechtiefe begrenzt auf t_{max} = 1 mm, größere Tiefen sind abhängig vom Ø zu betrachten.

Max. depth of groove can be reached only with width of cut ≥ 1,1 mm

Smaller inserts have a limited depth of groove t_{max} = 1 mm and deeper depths are depending on Ø of workpiece.

HM-Sorten
Carbide grades
Abmessungen in mm
Dimensions in mm

Einstechen (außen und innen)

Grooving (external and internal)



Wendeschneidplatte

Indexable insert

217

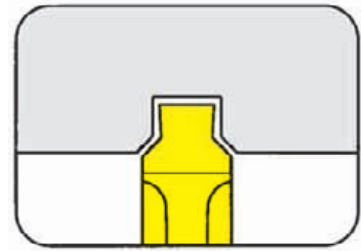

Seegerringnuten
Nutnennbreite Nw

Circlip grooves
Width of circlip Nw

DIN 471/472
1,1-4,15 mm

mit Nutaußenkantenfasung
with chamfer

für Klemmhalter
for Toolholder

Typ 234
Type 235
240
248
254
255

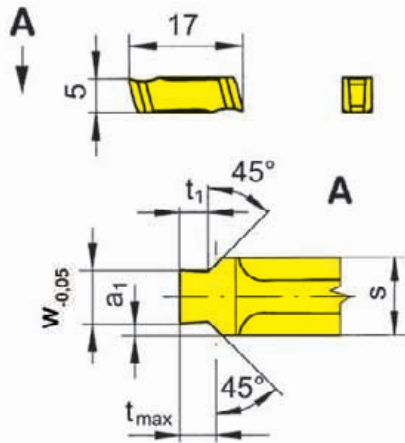

bei Sonderabmessungen
bitte angeben: w, t₁, t_{max}
for special dimensions please
state: w, t₁, t_{max}

Bestellnummer Part number	w	Nw	t _{max}	a ₁	s	t ₁	Größe Size	MG12	P20	TN32
217.1101.25	1,24	1,10	0,20	0,64	2,5	0,19	02	Δ	Δ	
217.1102.25	1,24	1,10	0,25	0,64	2,5	0,24	02	Δ	Δ	
217.1103.25	1,24	1,10	0,30	0,64	2,5	0,29	02	Δ	Δ	
217.1104.25	1,24	1,10	0,35	0,64	2,5	0,33	02	Δ	Δ	
217.1105.25	1,24	1,10	0,40	0,64	2,5	0,36	02	Δ	Δ	
217.1306.25	1,44	1,30	0,55	0,54	2,5	0,45	02		Δ	▲
217.1607.33	1,74	1,60	0,70	0,79	3,3	0,60	03		Δ	Δ
217.1608.33	1,74	1,60	0,85	0,79	3,3	0,75	03	Δ	Δ	
217.1609.33	1,74	1,60	1,00	0,79	3,3	0,85	03			▲
217.1810.33	1,99	1,85	1,00	0,67	3,3	0,85	03	Δ	Δ	
217.1812.33	1,99	1,85	1,25	0,67	3,3	1,10	03		Δ	▲
217.2115.43	2,29	2,15	1,50	1,02	4,3	1,35	04		Δ	▲
217.2616.43	2,79	2,65	1,50	0,77	4,3	1,35	04			▲
217.2617.43	2,79	2,65	1,75	0,77	4,3	1,60	04			▲
217.3118.53	3,29	3,15	1,75	1,02	5,3	1,60	04			▲
217.4120.53	4,29	4,15	2,00	0,52	5,3	1,85	04			▲
217.4125.53	4,29	4,15	2,50	0,52	5,3	2,35	04	Δ	Δ	

▲ ab Lager / on stock Δ 4 Wochen / 4 weeks x auf Anfrage / upon request

● empfohlen / recommended

○ bedingt einsetzbar / alternative recommendation

- nicht geeignet / not suitable

■ unbeschichtete HM-Sorten / uncoated grades

■ beschichtete HM-Sorten / coated grades

■ bestückt/Cermet / brazed/Cermet

Abmessungen in mm

Dimensions in mm

Schneidplatten sind in **rechten und linken** Klemmhaltern verwendbar.

Indexable inserts can be used in **right and left** hand toolholders.

P	○	●	●
M	●	-	-
K	●	-	-
N	●	-	-
S	●	-	-
H	-	-	-

HM-Sorten
Carbide grades

Einstechen (außen und innen)

Grooving (external and internal)



Wendeschneidplatte

Indexable insert

217

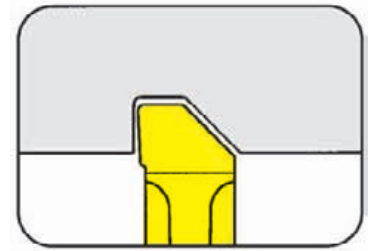

Gewindereifstiche DIN 76 „Kurzausführung“
Thread relief DIN 76 „Short form“

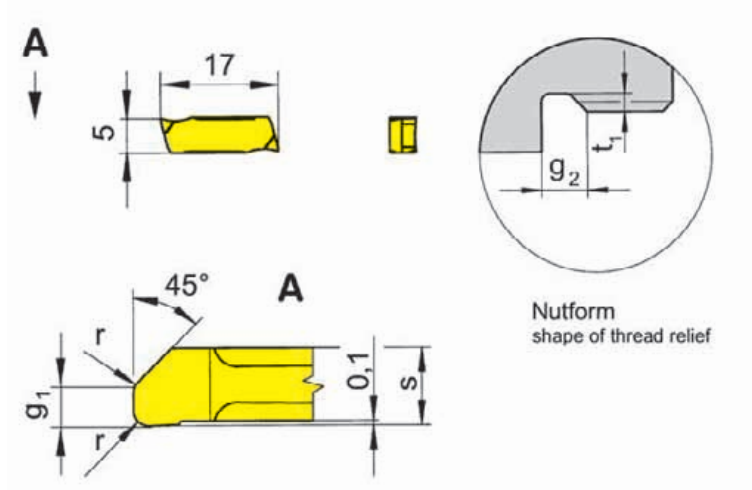

für Klemmhalter
for Toolholder

- Typ 234
- Type 235
- 240
- 248
- 254
- 255

R = rechts wie gezeichnet
R = right hand version shown

L = links spiegelbildlich
L = left hand version

Bestellnummer Part number	r	t ₁	s	g ₁	P	g ₂	Größe Size	P20
R/L217.1050.17	0,2	0,50	1,7	1,25	0,50	1,75	01	ΔΔ
R/L217.1060.27	0,4	0,55	2,7	1,50	0,60	2,05	02	ΔΔ
R/L217.1070.27	0,4	0,60	2,7	1,75	0,70	2,35	02	ΔΔ
R/L217.1080.27	0,4	0,70	2,7	2,00	0,80	2,70	02	ΔΔ
R/L217.1100.37	0,6	0,90	3,7	2,50	1,00	3,40	03	▲/Δ
R/L217.1125.53	0,6	1,05	5,3	3,20	1,25	4,25	04	ΔΔ
R/L217.1150.53	0,8	1,20	5,3	3,80	1,50	5,00	04	ΔΔ

▲ ab Lager / on stock Δ 4 Wochen / 4 weeks x auf Anfrage / upon request

● empfohlen / recommended

o bedingt einsetzbar / alternative recommendation

- nicht geeignet / not suitable

■ unbeschichtete HM-Sorten / uncoated grades

■ beschichtete HM-Sorten / coated grades

■ bestückt/Cermet / brazed/Cermet

Abmessungen in mm

Dimensions in mm

Ausführung R oder L angeben

State R or L version

HM-Sorten
Carbide grades

P	•
M	-
K	-
N	-
S	-
H	-

Außenbearbeitung:

Rechte WSP in rechten, linke WSP in linken Klemmhaltern verwenden.

External machining:

Use right hand inserts in right hand toolholders and left hand inserts in left hand toolholders

Innenbearbeitung:

Rechte WSP in linken, linke WSP in rechten Klemmhaltern verwenden.

Internal machining:

Use right hand inserts in left hand toolholders and left hand inserts in right hand toolholders

F

Eckenfreistechen (innen)

Grooving Corner Reliefs (internal)



Wendeschneidplatte

Indexable insert

217

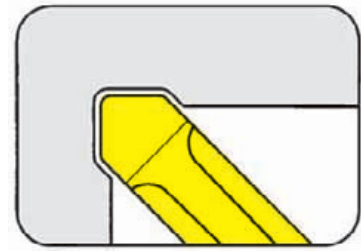

Eckenfreistechen ähnlich DIN 509 Form „F“
Corner reliefs similar to DIN 509 form „F“

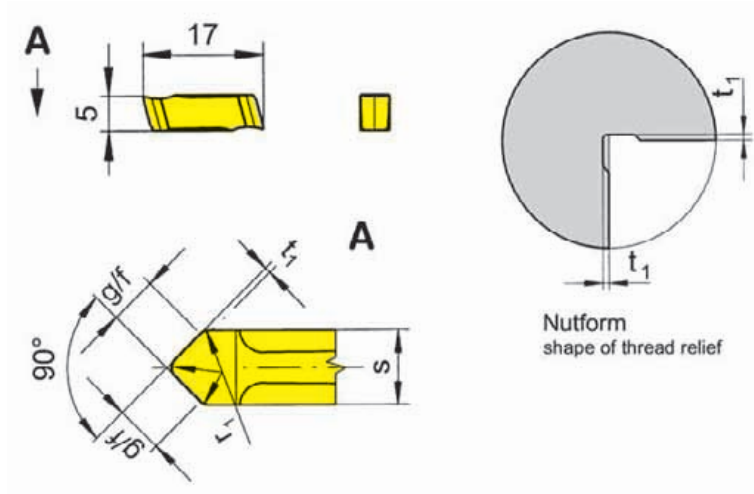

für Klemmhalter
for Toolholder

Typ 245
Type

F

Bestellnummer Part number	r_1	D_{min}	t_1	s	g/f	Größe Size	P20	TN32
217.0602.24	0,6	20	0,2	2,4	1,7	02	▲	▲
217.0603.33	0,6	23	0,3	3,3	2,3	03	▲	
217.1002.30	1,0	22	0,2	3,0	2,1	03	△	
217.1004.50	1,0	27	0,4	5,0	3,6	04	△	
217.1603.50	1,6	27	0,3	5,0	3,6	04	△	

▲ ab Lager / on stock △ 4 Wochen / 4 weeks x auf Anfrage / upon request

● empfohlen / recommended

o bedingt einsetzbar / alternative recommendation

- nicht geeignet / not suitable

■ unbeschichtete HM-Sorten / uncoated grades

■ beschichtete HM-Sorten / coated grades

■ bestückt/Cermet / brazed/Cermet

Abmessungen in mm

Dimensions in mm

Schneidplatten sind in **rechten und linken** Klemmhaltern verwendbar.

Indexable inserts can be used in **right and left** hand toolholders.

P	●	●
M	-	-
K	-	-
N	-	-
S	-	-
H	-	-

HM-Sorten
Carbide grades

Eckenfreistechen (innen)

Grooving Corner Reliefs (internal)



Wendeschneidplatte

Indexable insert

217

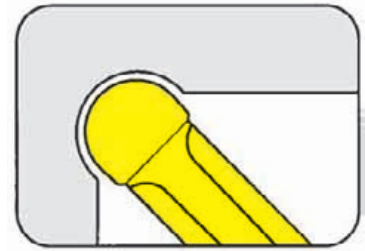

Vollradius	Full radius	1-2,5 mm
------------	-------------	----------

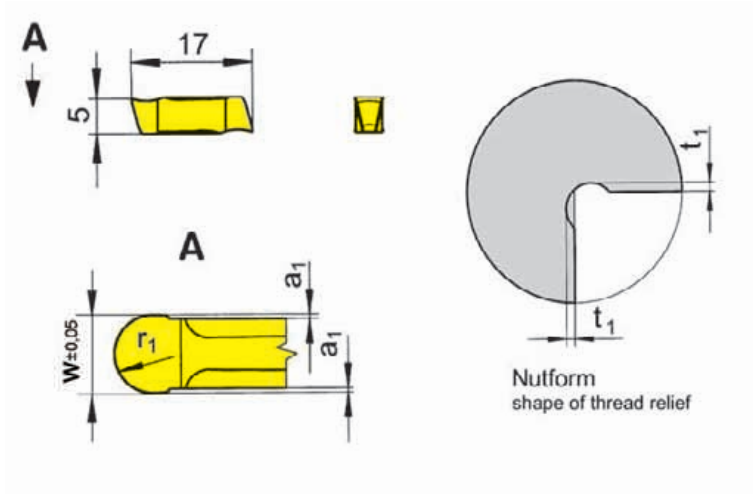

für Klemmhalter
for Toolholder

Typ 245
Type



Bestellnummer Part number	w	a _i	D _{min}	t _i	r _i	Größe Size	K10	P20	TC92	TF45	TI25	TN32	TN35	
217.0010.20	2	0,1	20	0,75	1,0	02	▲	▲	▲	▲	▲	▲	▲	
217.0015.30	3	0,1	20	1,00	1,5	03	▲	▲				▲	▲	
217.0020.40	4	0,1	20	1,25	2,0	04		▲					▲	
217.0025.50	5	0,1	20	1,50	2,5	04	▲	▲						
							P	●	●	●	●	●	●	
							M	○	-	-	●	●	-	●
							K	●	-	-	●	●	-	●
							N	●	-	-	●	●	-	●
							S	○	-	-	●	●	-	●
							H	-	-	-	-	-	-	-

▲ ab Lager / on stock Δ 4 Wochen / 4 weeks x auf Anfrage / upon request

● empfohlen / recommended

○ bedingt einsetzbar / alternative recommendation

- nicht geeignet / not suitable

□ unbeschichtete HM-Sorten / uncoated grades

■ beschichtete HM-Sorten / coated grades

■ bestückt/Cermet / brazed/Cermet

Abmessungen in mm

Dimensions in mm

Schneidplatten sind in **rechten und linken** Klemmhaltern verwendbar.

Indexable inserts can be used in **right and left** hand toolholders.

HM-Sorten
Carbide grades

Einstecken (innen)

Grooving (internal)



Kurzklemmhalter

Cartridge

232

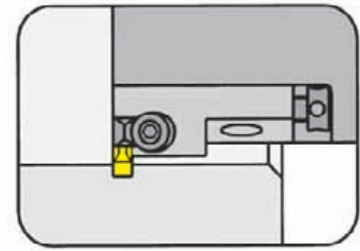

Bohrungs-Ø ab	Bore Ø from	40 mm
---------------	-------------	-------

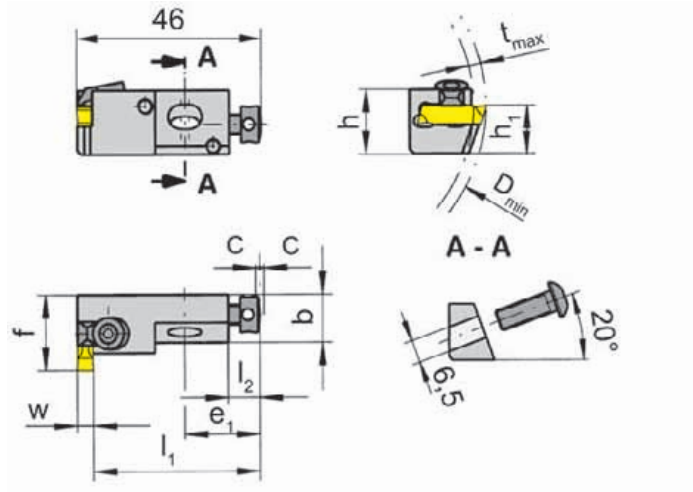

Wendeschneidplatte
Indexable insert

Typ 217
Type

F

R = rechts wie gezeichnet
R = right hand version shown

L = links spiegelbildlich
L = left hand version

Bestellnummer Part number	h	b	h ₁	f	l ₁	e ₁	l ₂	C	D _{min}	t _{max}	Größe Size	Spannbereich Clamping range
R232.1212.01	16	12	12	19	44,4	19	8	1	40	3	01	0,9-1,7
R232.1212.02	16	12	12	19	43,4	19	8	1	40	3	02	1,7-2,7
R232.1212.03	16	12	12	19	42,4	19	8	1	40	3	03	2,7-3,7
R232.1212.04	16	12	12	19	40,7	19	8	1	40	3	04	3,7-5,3

Ausführung R oder L angeben
State R or L version

Abmessungen in mm
Dimensions in mm

Weitere Abmessungen auf Anfrage
Further sizes upon request

Einbaumaße siehe Folgeseite
Dimensions of seating see following page

Das Anzugsdrehmoment der Schrauben finden Sie in den Technischen Hinweisen.
For torque specification of the screw, please see Technical Instructions.

Ersatzteile

Spare Parts

Kurzklemmhalter Cartridge	Spannschraube Screw	Inbus-Schlüssel Wrench	Schraube Screw	Spannelement Clamping element
R232.1212....	4.08.913	SW2,5 DIN911	6.20.232	8.3
R232.1212.04	4.08.913	SW2,5 DIN911	6.20.232	8.4

Einstecken (innen)

Grooving (internal)



Einbaumaße Kurzklemmhalter

232

Seating Dimensions Cartridge

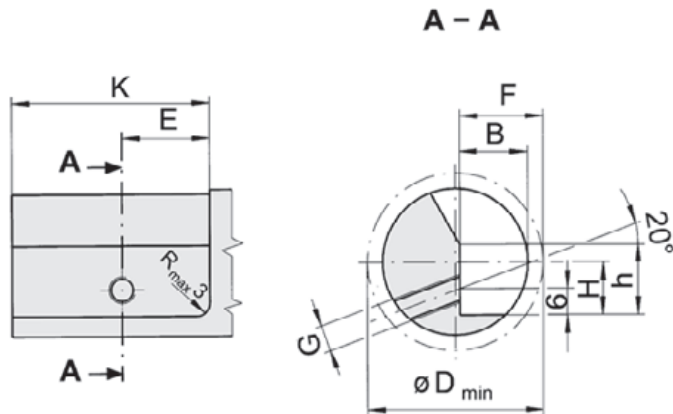
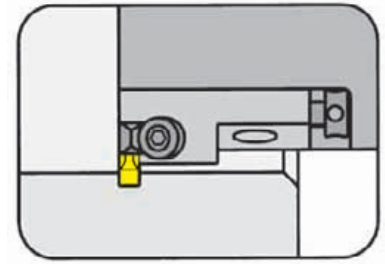

F

Kurzklemmhalter Cartridge	F	G	H	K	E	B	h	D _{min}	Befestigungsschraube Fastening screw
232.1212...	19	M6	12	45	20	15,5	16	40	6.20.232

Abmessungen in mm
Dimensions in mm

F



224



G

**Klemmhalter mit
Schneidplatten**

Stechbreite 2 - 6 mm

**Toolholder with
Inserts**

Width of groove 2 - 6 mm

Einstecken und Längsdrehen (außen)

Grooving and Side Turning (external)



Klemmhalter
Toolholder
H224/B224/224

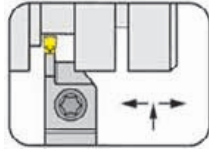

Seite/Page
G3-G10,G12-G17

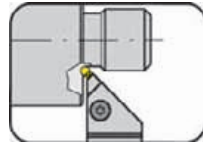

Seite/Page
G18



Seite/Page
G19, G22-G23

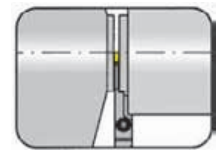

Seite/Page
G11, G20-G21

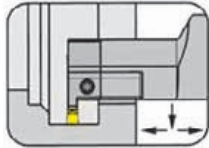

Seite/Page
G24-G28

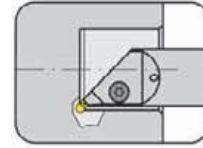

Seite/Page
G30-G31

Kassette
Cassette
BK224

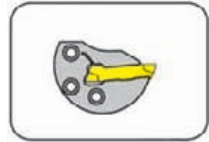

Seite/Page
G27

Schneidplatte
Inserts
S224/224/NS224

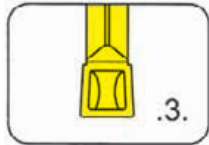

Seite/Page
G32-G33

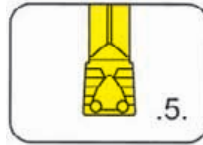

Seite/Page
G34-G35

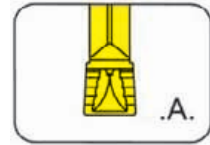

Seite/Page
G36-G37

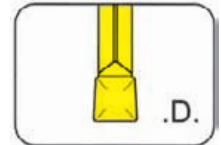

Seite/Page
G38-G39

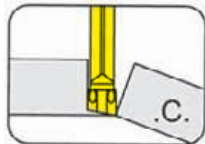

Seite/Page
G40-G41



Seite/Page
G42

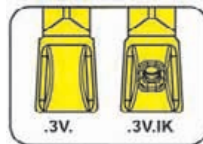

Seite/Page
G43,G55

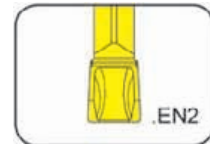

Seite/Page
G44

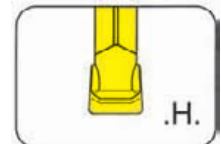

Seite/Page
G45

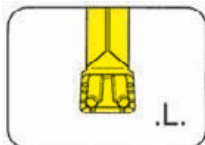

Seite/Page
G46-L47

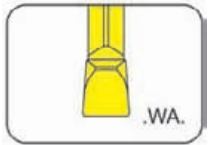

Seite/Page
G48

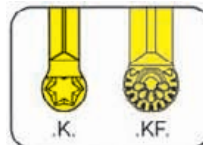

Seite/Page
G49-G50

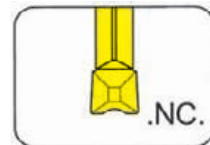

Seite/Page
G51

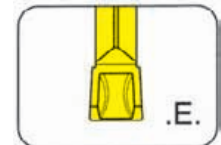

Seite/Page
G52

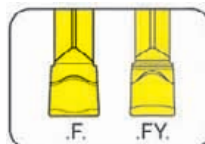

Seite/Page
G53-G54

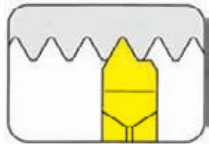

Seite/Page
G56-G57

G

Einstechen und Abstechen

Grooving and Parting Off



Klemmhalter

Toolholder

H224

mit Schraubklemmung
with screwed clamping

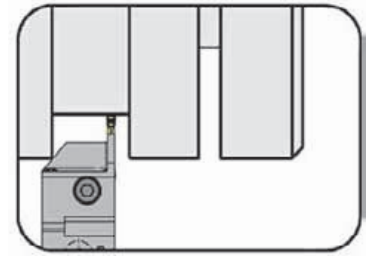

Stechtiefe bis Stechbreite	Depth of groove up to Width of groove	18 mm 3 mm
-------------------------------	--	---------------

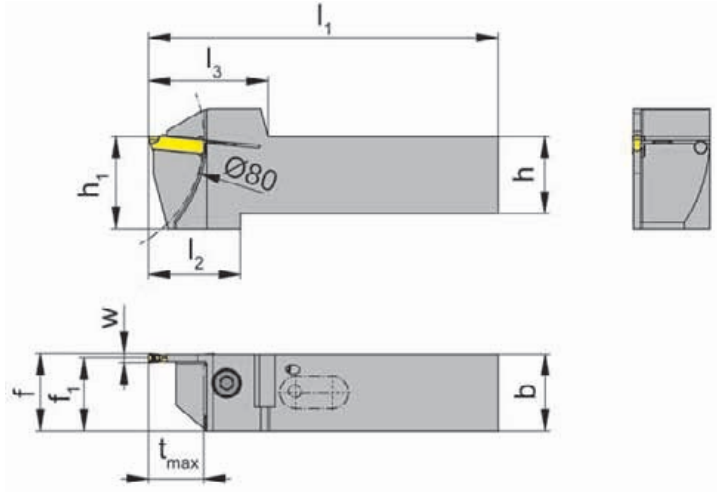

für Wendeschneidplatte
for Indexable insert

Typ S224...IK
Type

Kühlmittelzufuhr durch die
Schneidplatte
Coolant supply through insert

L = links wie gezeichnet
L = left hand version shown

R = rechts spiegelbildlich
R = right hand version

Bestellnummer Part number	h	b	l ₁	l ₂	l ₃	h ₁	f ₁	f	t _{max}	Größe Size
RH224.1616.3.23.IK	16	16	87	33	39	25	14,75	f ₁ +w/2	18	03
RH224.2020.3.23.IK	20	20	99	30	39	25	18,75	f ₁ +w/2	18	03
RH224.2525.3.23.IK	25	25	114	30	39	30	23,75	f ₁ +w/2	18	03

Ausführung R oder L angeben
State R or L version

w siehe WSP
w see indexable inserts

Abmessungen in mm
Dimensions in mm

Weitere Abmessungen auf Anfrage
Further sizes upon request

Das Anzugsdrehmoment der Schrauben finden Sie in den Technischen Hinweisen.
For torque specification of the screw, please see Technical Instructions.

Ersatzteile

Spare Parts

Klemmhalter Toolholder	Spannschraube Screw	TORX PLUS®-Schlüssel TORX PLUS® Wrench
RH224...	6.23T25P	T25PQ

Einstecken und Längsdrehen (außen)

Grooving and Side Turning (external)



Klemmhalter

Toolholder

H224

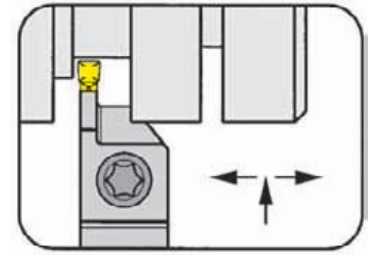

Stechtiefe bis
Spannbereich

Depth of groove up to
Clamping range

14 mm
2,0 - 3,7 mm

für Wendeschneidplatte
for Indexable insert

Typ S224
Type NS224

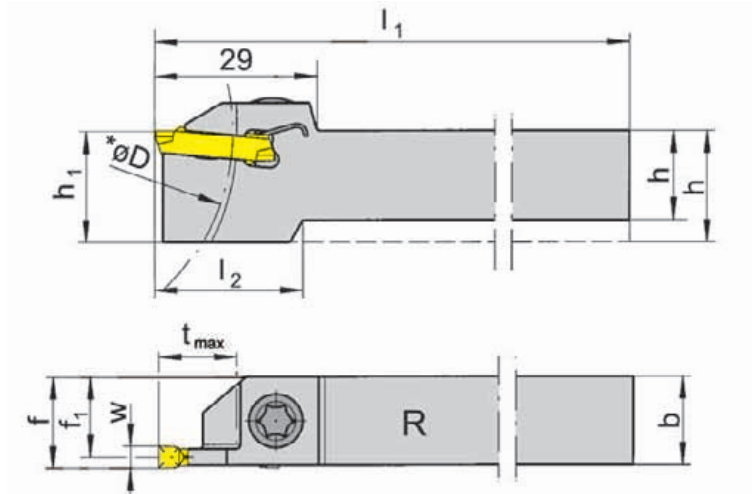

R = rechts wie gezeichnet
R = right hand version shown

L = links spiegelbildlich
L = left hand version

Bestellnummer Part number	h	b	l ₁	l ₂	h ₁	f ₁	f	t _{max}	D _{max}	Größe Size	Spannbereich Clamping range
R/LH224.1616.01	16	16	125	25	20	15,3	f ₁ +w/2	14	80	01	2,0-2,4
R/LH224.2020.01	20	20	125	-	20	19,3	f ₁ +w/2	14	80	01	2,0-2,4
R/LH224.2525.01	25	25	150	-	25	24,3	f ₁ +w/2	14	80	01	2,0-2,4
RH224.1608.02	16	8	100	30	20	7,1	f ₁ +w/2	14	80	02	2,4-2,8
R/LH224.1616.02	16	16	125	25	20	15,1	f ₁ +w/2	14	80	02	2,4-2,8
R/LH224.2020.02	20	20	125	-	20	19,1	f ₁ +w/2	14	80	02	2,4-2,8
R/LH224.2525.02	25	25	150	-	25	24,1	f ₁ +w/2	14	80	02	2,4-2,8
R/LH224.1616.03	16	16	125	25	20	14,9	f ₁ +w/2	14	80	03	2,8-3,7
R/LH224.2020.03	20	20	125	-	20	18,9	f ₁ +w/2	14	80	03	2,8-3,7
R/LH224.2525.03	25	25	150	-	25	23,9	f ₁ +w/2	14	80	03	2,8-3,7

Ausführung R oder L angeben
State R or L version

w siehe WSP
w see indexable inserts

Abmessungen in mm
Dimensions in mm

Weitere Abmessungen auf Anfrage

Further sizes upon request

* t_{max} bis D = 80 mm

* t_{max} up to D = 80 mm

Das Anzugsdrehmoment der Schrauben finden Sie in den Technischen Hinweisen.

For torque specification of the screw, please see Technical Instructions.

Ersatzteile

Spare Parts

Klemmhalter Toolholder	Spannschraube Screw	TORX PLUS®-Schlüssel TORX PLUS® Wrench
R/LH224...	6.23T25P	T25PQ
R/LH224.1608.02	4.15T15P	T15PL

Einstecken und Längsdrehen (außen)

Grooving and Side Turning (external)



Klemmhalter

Toolholder

H224

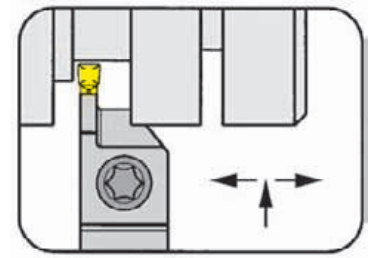

Stechtiefe bis
Spannbereich

Depth of groove up to
Clamping range

14 mm
3,7 - 6,1 mm

für Wendeschneidplatte
for Indexable insert

Typ S224
Type NS224

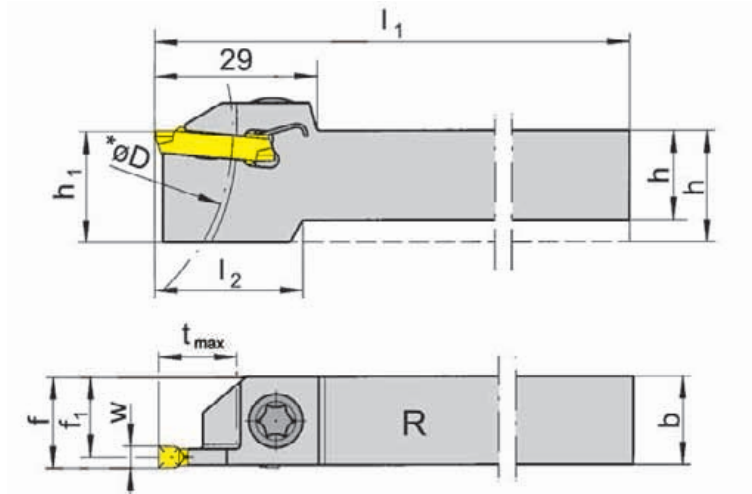

R = rechts wie gezeichnet
R = right hand version shown

L = links spiegelbildlich
L = left hand version

Bestellnummer Part number	h	b	l ₁	l ₂	h ₁	f ₁	f	t _{max}	D _{max}	Größe Size	Spannbereich Clamping range
R/LH224.1616.04	16	16	125	25	20	14,55	f ₁ +w/2	14	80	04	3,7-4,4
R/LH224.2020.04	20	20	125	-	20	18,55	f ₁ +w/2	14	80	04	3,7-4,4
R/LH224.2525.04	25	25	150	-	25	23,55	f ₁ +w/2	14	80	04	3,7-4,4
R/LH224.1616.05	16	16	125	-	20	18,15	f ₁ +w/2	14	80	05	4,4-5,1
R/LH224.2020.05	20	20	125	-	20	18,15	f ₁ +w/2	14	80	05	4,4-5,1
R/LH224.2525.05	25	25	150	-	25	23,15	f ₁ +w/2	14	80	05	4,4-5,1
R/LH224.2020.06	20	20	125	-	20	17,75	f ₁ +w/2	14	80	06	5,1-6,1
R/LH224.2525.06	25	25	150	-	25	22,75	f ₁ +w/2	14	80	06	5,1-6,1

Ausführung R oder L angeben
State R or L version

w siehe WSP
w see indexable inserts

Abmessungen in mm
Dimensions in mm

Weitere Abmessungen auf Anfrage
Further sizes upon request

* t_{max} bis D = 80 mm

* t_{max} up to D = 80 mm

Das Anzugsdrehmoment der Schrauben finden Sie in den Technischen Hinweisen.
For torque specification of the screw, please see Technical Instructions.

Ersatzteile

Spare Parts

Klemmhalter Toolholder	Spannschraube Screw	TORX PLUS®-Schlüssel TORX PLUS® Wrench
R/LH224...	6.23T25P	T25PQ

Einstecken und Längsdrehen (außen)

Grooving and Side Turning (external)



Klemmhalter

Toolholder

H224

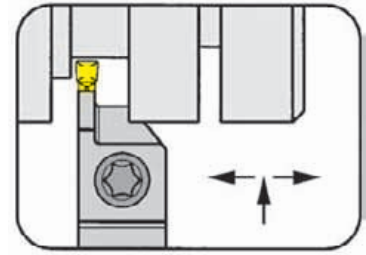

Stechtiefe bis Spannbereich	Depth of groove up to Clamping range	14 mm 2,0 - 3,7 mm
--------------------------------	---	-----------------------

für Wendeschneidplatte
for Indexable insert

Typ S224
Type NS224

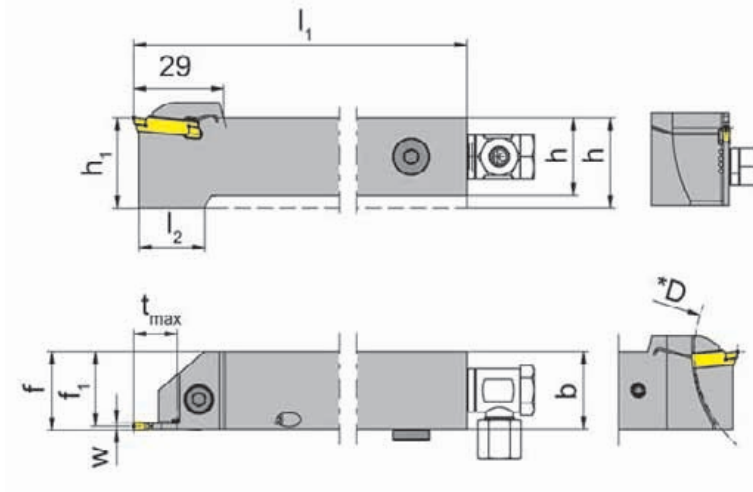

R = rechts wie gezeichnet
R = right hand version shown

L = links spiegelbildlich
L = left hand version

mit innerer
Kühlmittelzufuhr
with through coolant supply

Bestellnummer Part number	h	b	l ₁	l ₂	h ₁	f ₁	f	t _{max}	D _{max}	Größe Size	Spannbereich Clamping range
R/LH224.1616.01.IK	16	16	125	25	20	15,3	f ₁ +w/2	14	80	01	2,0-2,4
R/LH224.2020.01.IK	20	20	125	-	20	19,3	f ₁ +w/2	14	80	01	2,0-2,4
R/LH224.2525.01.IK	25	25	150	-	25	24,3	f ₁ +w/2	14	80	01	2,0-2,4
R/LH224.1616.02.IK	16	16	125	25	20	15,1	f ₁ +w/2	14	80	02	2,4-2,8
R/LH224.2020.02.IK	20	20	125	-	20	19,1	f ₁ +w/2	14	80	02	2,4-2,8
R/LH224.2525.02.IK	25	25	150	-	25	24,1	f ₁ +w/2	14	80	02	2,4-2,8
R/LH224.1616.03.IK	16	16	125	25	20	14,9	f ₁ +w/2	14	80	03	2,8-3,7
R/LH224.2020.03.IK	20	20	125	-	20	18,9	f ₁ +w/2	14	80	03	2,8-3,7
R/LH224.2525.03.IK	25	25	150	-	25	23,9	f ₁ +w/2	14	80	03	2,8-3,7

Ausführung R oder L angeben
State R or L version

w siehe WSP
w see indexable inserts

Abmessungen in mm
Dimensions in mm

Weitere Abmessungen auf Anfrage
Further sizes upon request

* t_{max} bis D = 80 mm

* t_{max} up to D = 80 mm

Das Anzugsdrehmoment der Schrauben finden Sie in den Technischen Hinweisen.
For torque specification of the screw, please see Technical Instructions.

Ersatzteile

Spare Parts

Klemmhalter Toolholder	Dichtstopfen Sealing plug	Kühlmittelanschluss Coolant supply	Spannschraube Screw	TORX PLUS®-Schlüssel TORX PLUS® Wrench
R/LH224...	004.00.26	004.00.16	6.23T25P	T25PQ

Einstechen und Abstechen

Grooving and Parting Off



Klemmhalter

Toolholder

H224

mit Schraubklemmung
with screwed clamping

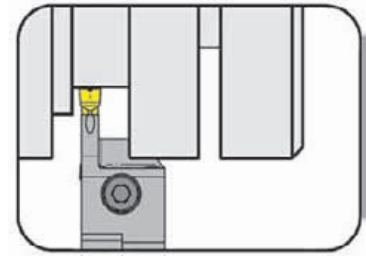

Stechtiefe bis Stechbreite	Depth of groove up to Width of groove	14 mm 3,0 - 5,0 mm
-------------------------------	--	-----------------------

für Wendeschneidplatte
for Indexable insert

Typ S224
Type NS224

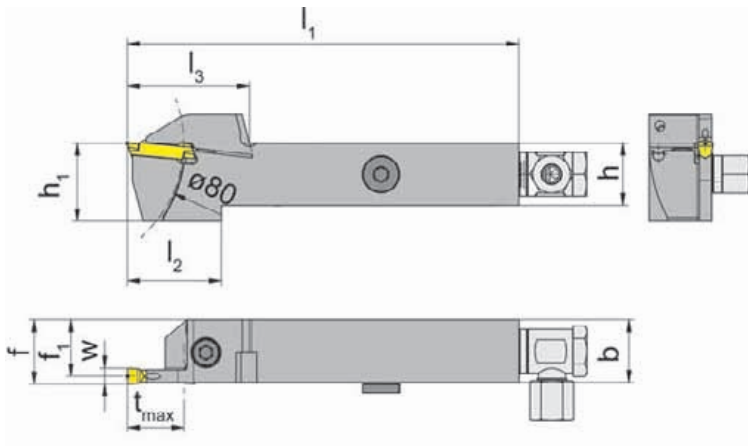

R = rechts wie gezeichnet
R = right hand version shown

L = links spiegelbildlich
L = left hand version

mit innerer
Kühlmittelzufuhr
with through coolant supply

Bestellnummer Part number	h	b	l ₁	l ₂	l ₃	h ₁	f ₁	f	t _{max}	Größe Size
R/LH224.1616.0.03.IK	16	16	125	29	35	25	14,75	f ₁ +w/2	14	03
R/LH224.2020.0.03.IK	20	20	125	26	35	25	18,75	f ₁ +w/2	14	03
R/LH224.2525.0.03.IK	25	25	150	26	35	30	23,75	f ₁ +w/2	14	03
R/LH224.1616.0.04.IK	16	16	125	29	35	25	14,30	f ₁ +w/2	14	04
R/LH224.2020.0.04.IK	20	20	125	26	35	25	18,30	f ₁ +w/2	14	04
R/LH224.2525.0.04.IK	25	25	150	26	35	30	23,30	f ₁ +w/2	14	04
R/LH224.1616.0.05.IK	16	16	125	29	35	25	13,95	f ₁ +w/2	14	05
R/LH224.2020.0.05.IK	20	20	125	26	35	25	17,95	f ₁ +w/2	14	05
R/LH224.2525.0.05.IK	25	25	150	26	35	30	22,95	f ₁ +w/2	14	05

Ausführung R oder L angeben
State R or L version

w siehe WSP
w see indexable inserts

Abmessungen in mm
Dimensions in mm

Weitere Abmessungen auf Anfrage
Further sizes upon request

Das Anzugsdrehmoment der Schrauben finden Sie in den Technischen Hinweisen.
For torque specification of the screw, please see Technical Instructions.

Ersatzteile

Spare Parts

Klemmhalter Toolholder	Dichtstopfen Sealing plug	Kühlmittelanschluss Coolant supply	Spannschraube Screw	TORX PLUS®-Schlüssel TORX PLUS® Wrench
R/LH224...	004.00.26	004.00.16	6.23T25P	T25PQ

Einstechen und Abstechen

Grooving and Parting Off



Klemmhalter

Toolholder

H224

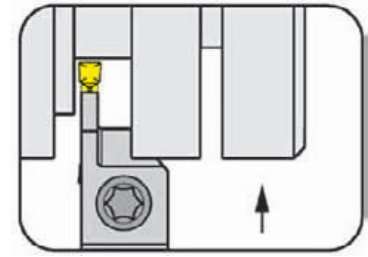

Stechtiefe bis Spannbereich	Depth of groove up to Clamping range	18,0 mm 2,0 - 3,7 mm
--------------------------------	---	-------------------------

für Wendeschneidplatte
for Indexable insert

Typ S224
Type NS224

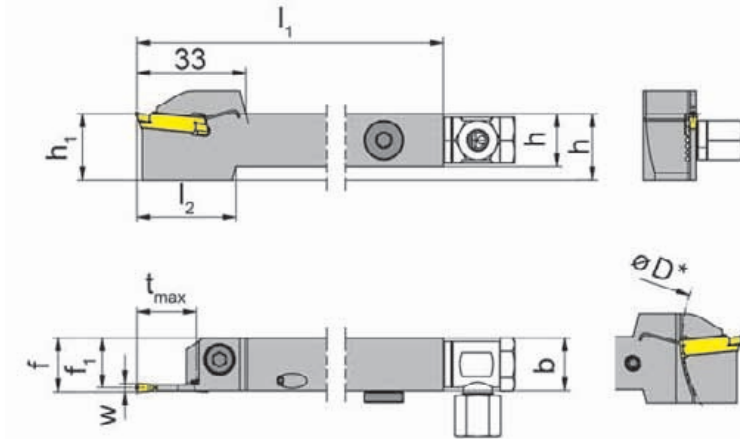

R = rechts wie gezeichnet
R = right hand version shown

L = links spiegelbildlich
L = left hand version

mit innerer
Kühlmittelzufuhr
with through coolant supply

Bestellnummer Part number	h	b	l ₁	l ₂	h ₁	f ₁	f	t _{max}	D _{max}	Größe Size	Spannbereich Clamping range
R/LH224.1212.21.IK	12	12	125	33	20	11,3	f ₁ +w/2	18	80	01	2,0-2,4
R/LH224.1616.21.IK	16	16	125	30	20	15,3	f ₁ +w/2	18	80	01	2,0-2,4
R/LH224.2020.21.IK	20	20	125	-	20	19,3	f ₁ +w/2	18	80	01	2,0-2,4
R/LH224.2525.21.IK	25	25	150	-	25	24,3	f ₁ +w/2	18	80	01	2,0-2,4
R/LH224.1212.22.IK	12	12	125	33	20	11,1	f ₁ +w/2	18	80	02	2,4-2,8
R/LH224.1616.22.IK	16	16	125	30	20	15,1	f ₁ +w/2	18	80	02	2,4-2,8
R/LH224.2020.22.IK	20	20	125	-	20	19,1	f ₁ +w/2	18	80	02	2,4-2,8
R/LH224.2525.22.IK	25	25	150	-	25	24,1	f ₁ +w/2	18	80	02	2,4-2,8
R/LH224.1212.23.IK	12	12	125	33	20	10,9	f ₁ +w/2	18	80	03	2,8-3,7
R/LH224.1616.23.IK	16	16	125	30	20	14,9	f ₁ +w/2	18	80	03	2,8-3,7
R/LH224.2020.23.IK	20	20	125	-	20	18,9	f ₁ +w/2	18	80	03	2,8-3,7
R/LH224.2525.23.IK	25	25	150	-	25	23,9	f ₁ +w/2	18	80	03	2,8-3,7

Ausführung R oder L angeben
State R or L version

w siehe WSP
w see indexable inserts

Abmessungen in mm
Dimensions in mm

Weitere Abmessungen auf Anfrage
Further sizes upon request

* t_{max} bis D = 80 mm

* t_{max} up to D = 80 mm

Das Anzugsdrehmoment der Schrauben finden Sie in den Technischen Hinweisen.
For torque specification of the screw, please see Technical Instructions.

Ersatzteile

Spare Parts

Klemmhalter Toolholder	Kühlmittelanschluss Coolant supply	Spannschraube Screw	TORX PLUS®-Schlüssel TORX PLUS® Wrench	Dichtstopfen Sealing plug
R/LH224....	004.00.16	6.23T25P	T25PQ	004.00.26
R/LH224.1212.22.IK	004.00.61	6.23T25P	T25PQ	
R/LH224.1212.23.IK	004.00.61	6.23T25P	T25PQ	
R/LH224.2525.23.IK	004.00.61	6.23T25P	T25PQ	

Einstechen und Abstechen

Grooving and Parting Off



Klemmhalter

Toolholder

H224

mit Schraubklemmung
with screwed clamping

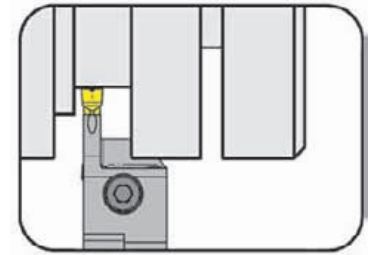

Stechtiefe bis Stechbreite	Depth of groove up to Width of groove	18 mm 3,0 - 5,0 mm
-------------------------------	--	-----------------------

für Wendeschneidplatte
for Indexable insert

Typ S224
Type NS224

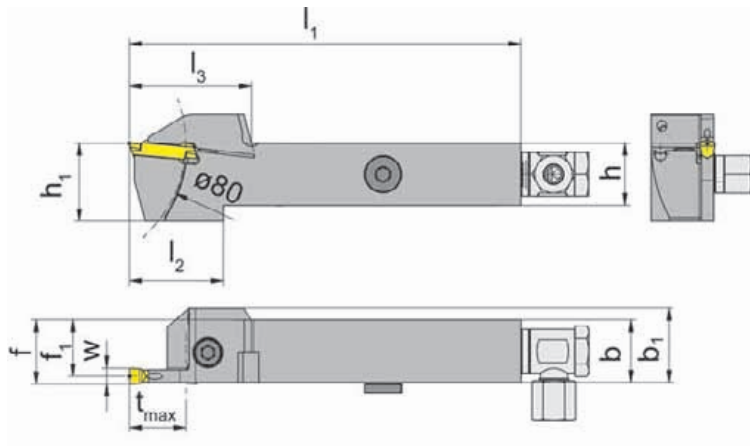

R = rechts wie gezeichnet
R = right hand version shown

L = links spiegelbildlich
L = left hand version

mit innerer
Kühlmittelzufuhr
with through coolant supply

Bestellnummer Part number	h	b	l ₁	l ₂	l ₃	h ₁	f ₁	f	t _{max}	b ₁	Größe Size
R/LH224.1616.0.23.IK	16	16	125	33	39	25	14,75	f ₁ +w/2	18	20	03
R/LH224.2020.0.23.IK	20	20	125	30	39	25	18,75	f ₁ +w/2	18	-	03
R/LH224.2525.0.23.IK	25	25	150	30	39	30	23,75	f ₁ +w/2	18	-	03
R/LH224.1616.0.24.IK	16	16	125	33	39	25	14,30	f ₁ +w/2	18	20	04
R/LH224.2020.0.24.IK	20	20	125	30	39	25	18,30	f ₁ +w/2	18	-	04
R/LH224.2525.0.24.IK	25	25	150	30	39	30	23,30	f ₁ +w/2	18	-	04
R/LH224.1616.0.25.IK	16	16	125	33	39	25	13,95	f ₁ +w/2	18	20	05
R/LH224.2020.0.25.IK	20	20	125	30	39	25	17,95	f ₁ +w/2	18	-	05
R/LH224.2525.0.25.IK	25	25	150	30	39	30	23,95	f ₁ +w/2	18	-	05

Ausführung R oder L angeben
State R or L version

w siehe WSP
w see indexable inserts

Abmessungen in mm
Dimensions in mm

Weitere Abmessungen auf Anfrage
Further sizes upon request

Das Anzugsdrehmoment der Schrauben finden Sie in den Technischen Hinweisen.
For torque specification of the screw, please see Technical Instructions.

Ersatzteile

Spare Parts

Klemmhalter Toolholder	Kühlmittelanschluss Coolant supply	Spannschraube Screw	TORX PLUS®-Schlüssel TORX PLUS® Wrench	Dichtstopfen Sealing plug
R/LH224...	004.00.16	6.23T25P	T25PQ	004.00.26

Einstechen und Abstechen

Grooving and Parting Off



Klemmhalter

Toolholder

H224

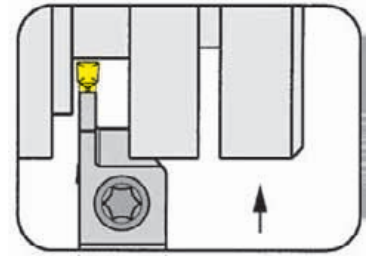

Stechtiefe bis
Spannbereich

Depth of groove up to
Clamping range

18 mm
2,0 - 3,7 mm

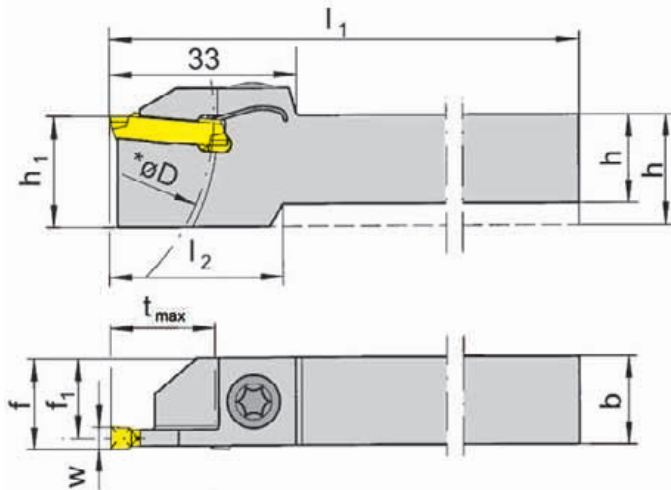

für Wendeschneidplatte
for Indexable insert

Typ S224
Type NS224

R = rechts wie gezeichnet
R = right hand version shown

L = links spiegelbildlich
L = left hand version

Bestellnummer Part number	h	b	l ₁	l ₂	h ₁	f ₁	f	t _{max}	D _{max}	Größe Size	Spannbereich Clamping range
R/LH224.1212.21	12	12	125	33	20	11,3	f ₁ +w/2	18	80	01	2,0-2,4
R/LH224.1616.21	16	16	125	30	20	15,3	f ₁ +w/2	18	80	01	2,0-2,4
R/LH224.2020.21	20	20	125	-	20	19,3	f ₁ +w/2	18	80	01	2,0-2,4
R/LH224.2525.21	25	25	150	-	25	24,3	f ₁ +w/2	18	80	01	2,0-2,4
R/LH224.1212.22	12	12	125	33	20	11,1	f ₁ +w/2	18	80	02	2,4-2,8
R/LH224.1616.22	16	16	125	30	20	15,1	f ₁ +w/2	18	80	02	2,4-2,8
R/LH224.2020.22	20	20	125	-	20	19,1	f ₁ +w/2	18	80	02	2,4-2,8
R/LH224.2525.22	25	25	150	-	25	24,1	f ₁ +w/2	18	80	02	2,4-2,8
R/LH224.1212.23	12	12	125	33	20	10,9	f ₁ +w/2	18	80	03	2,8-3,7
R/LH224.1608.23	16	8	100	-	20	6,9	f ₁ +w/2	18	80	03	2,8-3,7
R/LH224.1616.23	16	16	125	30	20	14,9	f ₁ +w/2	18	80	03	2,8-3,7
R/LH224.2020.23	20	20	125	-	20	18,9	f ₁ +w/2	18	80	03	2,8-3,7
R/LH224.2525.23	25	25	150	-	25	23,9	f ₁ +w/2	18	80	03	2,8-3,7

Ausführung R oder L angeben
State R or L version

w siehe WSP
w see indexable inserts

Abmessungen in mm
Dimensions in mm

Weitere Abmessungen auf Anfrage
Further sizes upon request

* t_{max} bis D = 80 mm

* t_{max} up to D = 80 mm

Das Anzugsdrehmoment der Schrauben finden Sie in den Technischen Hinweisen.
For torque specification of the screw, please see Technical Instructions.

Ersatzteile

Spare Parts

Klemmhalter Toolholder	Spannschraube Screw	TORX PLUS®-Schlüssel TORX PLUS® Wrench
R/LH224...	6.23T25P	T25PQ
R/LH224.1608.23	4.15T15P	T15PQ

Einstecken und Abstechen

Grooving and Parting Off



Klemmhalter

Toolholder

H224

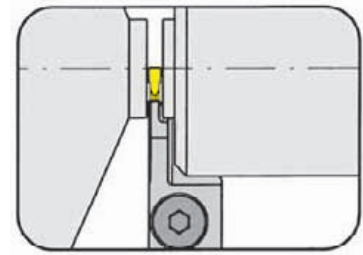

Stechtiefe bis Spannbereich	Depth of groove up to Clamping range	8,2 mm 2,0 - 2,4 mm
--------------------------------	---	------------------------

für TRAUB-Maschinen (TNL12/7)
for machines TRAUB (TNL12/7)

für Wendeschneidplatte
for Indexable insert

Typ S224
Type NS224

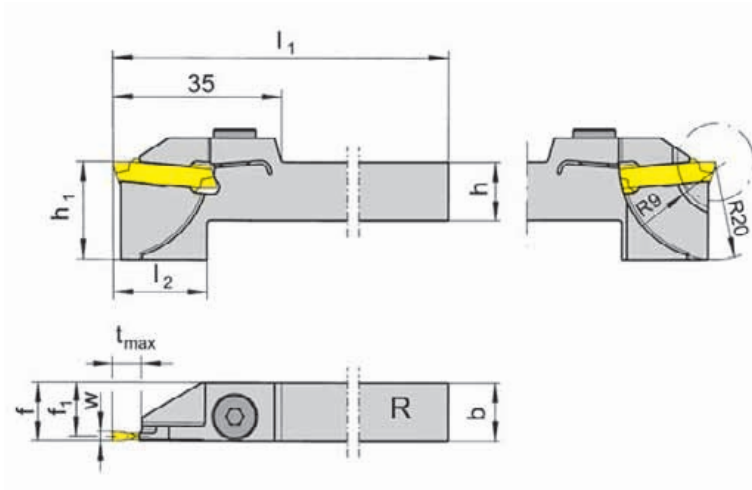

R = rechts wie gezeichnet
R = right hand version shown

Bestellnummer Part number	h	b	l ₁	l ₂	h ₁	f ₁	f	t _{max}	Größe Size	Spannbereich Clamping range
RH224.1212.81	12	12	95	19,5	20	11,1	f ₁ +w/2	8,2	01	2,0-2,4

Weitere Abmessungen auf Anfrage
Further sizes upon request

w siehe WSP
w see indexable inserts

Abmessungen in mm
Dimensions in mm

Das Anzugsdrehmoment der Schrauben finden Sie in den Technischen Hinweisen.
For torque specification of the screw, please see Technical Instructions.

Ersatzteile

Spare Parts

Klemmhalter Toolholder	Spannschraube Screw	TORX PLUS®-Schlüssel TORX PLUS® Wrench
RH224.1212.81	6.17T25P	T25PQ



Einstechen (außen)

Grooving (external)



Klemmhalter

Toolholder

H224

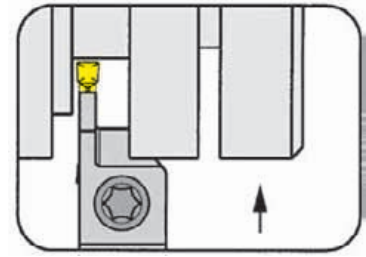

Stechtiefe bis Spannbereich	Depth of groove up to Clamping range	18 mm 3,7 - 6,1 mm
--------------------------------	---	-----------------------

für Wendeschneidplatte
for Indexable insert

Typ S224
Type NS224

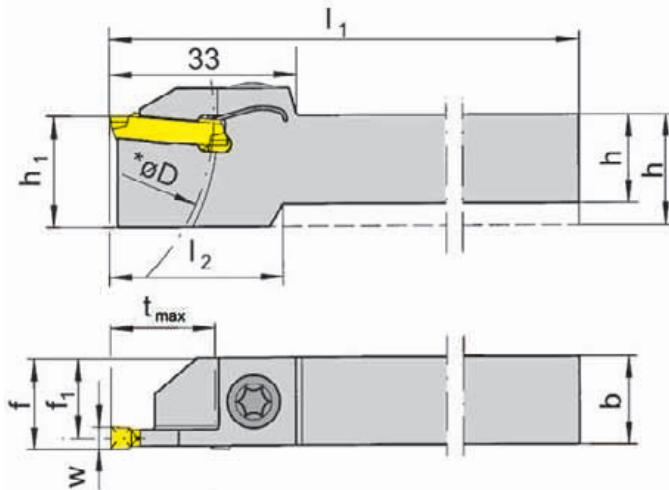

R = rechts wie gezeichnet
R = right hand version shown

L = links spiegelbildlich
L = left hand version

Bestellnummer Part number	h	b	l ₁	l ₂	h ₁	f ₁	f	t _{max}	D _{max}	Größe Size	Spannbereich Clamping range
R/LH224.1608.24	16	8	100	-	16	6,55	f ₁ +w/2	18	80	04	3,7-4,4
R/LH224.1616.24	16	16	125	30	20	14,55	f ₁ +w/2	18	80	04	3,7-4,4
R/LH224.2020.24	20	20	125	-	20	18,55	f ₁ +w/2	18	80	04	3,7-4,4
R/LH224.2525.24	25	25	150	-	25	23,55	f ₁ +w/2	18	80	04	3,7-4,4
R/LH224.1616.25	16	16	125	30	20	14,15	f ₁ +w/2	18	80	05	4,4-5,1
R/LH224.2020.25	20	20	125	-	20	18,15	f ₁ +w/2	18	80	05	4,4-5,1
R/LH224.2525.25	25	25	150	-	25	23,15	f ₁ +w/2	18	80	05	4,4-5,1
R/LH224.1616.26	16	16	125	30	20	13,75	f ₁ +w/2	18	80	06	5,1-6,1
R/LH224.2020.26	20	20	125	-	20	17,75	f ₁ +w/2	18	80	06	5,1-6,1
R/LH224.2525.26	25	25	150	-	25	22,75	f ₁ +w/2	18	80	06	5,1-6,1

Ausführung R oder L angeben
State R or L version

w siehe WSP
w see indexable inserts

Abmessungen in mm
Dimensions in mm

Weitere Abmessungen auf Anfrage

Further sizes upon request

* t_{max} bis D = 80 mm

* t_{max} up to D = 80 mm

Das Anzugsdrehmoment der Schrauben finden Sie in den Technischen Hinweisen.

For torque specification of the screw, please see Technical Instructions.

Ersatzteile

Spare Parts

Klemmhalter Toolholder	Spannschraube Screw	TORX PLUS®-Schlüssel TORX PLUS® Wrench
R/LH224.1608.24	4.15T15P	T15PQ
R/LH224...	6.23T25P	T25PQ

Einstechen und Längsdrehen (außen)

Grooving and Side Turning (external)



Klemmhalter

Toolholder

H224

mit Schraubklemmung
with screwed clamping

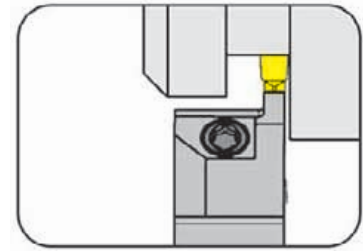

Stechtiefe bis
Spannbereich

Depth of groove up to
Clamping range

7 mm
2,0 - 4,4 mm

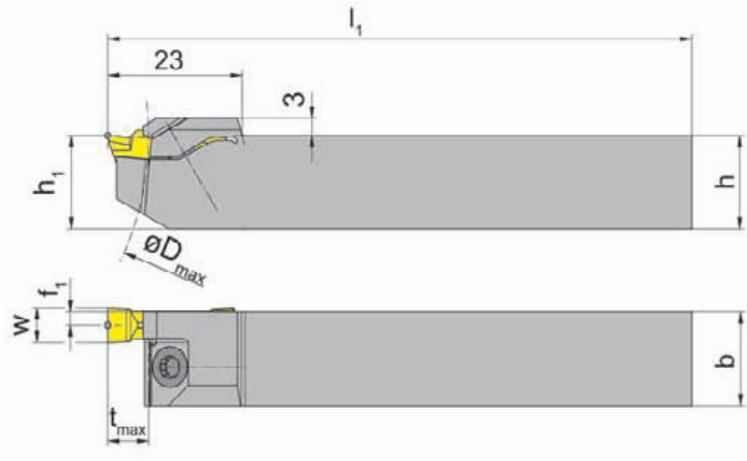

für Wendeschneidplatte
for Indexable insert

Typ S224
Type NS224

L = links wie gezeichnet
L = left hand version shown

R = rechts spiegelbildlich
R = right hand version

Bestellnummer Part number	h	b	l ₁	h ₁	f ₁	t _{max}	D _{max}	Größe Size	Spannbereich Clamping range
R/LH224.1212.61	12	12	100	12	0,70	7	100	01	2,0-2,4
R/LH224.1616.61	16	16	100	16	0,70	7	100	01	2,0-2,4
R/LH224.2020.61	20	20	100	20	0,70	7	100	01	2,0-2,4
R/LH224.1212.62	12	12	100	12	0,90	7	100	02	2,4-2,8
R/LH224.1616.62	16	16	100	16	0,90	7	100	02	2,4-2,8
R/LH224.2020.62	20	20	100	20	0,90	7	100	02	2,4-2,8
R/LH224.1212.63	12	12	100	12	1,10	7	100	03	2,8-3,7
R/LH224.1616.63	16	16	100	16	1,10	7	100	03	2,8-3,7
R/LH224.2020.63	20	20	100	20	1,10	7	100	03	2,8-3,7
R/LH224.1212.64	12	12	100	12	1,45	7	100	04	3,7-4,4
R/LH224.1616.64	16	16	100	16	1,45	7	100	04	3,7-4,4
R/LH224.2020.64	20	20	100	20	1,45	7	100	04	3,7-4,4

Ausführung R oder L angeben
State R or L version

w siehe WSP
w see indexable inserts

Abmessungen in mm
Dimensions in mm

Weitere Abmessungen auf Anfrage
Further sizes upon request

Das Anzugsdrehmoment der Schrauben finden Sie in den Technischen Hinweisen.
For torque specification of the screw, please see Technical Instructions.

Ersatzteile

Spare Parts

Klemmhalter Toolholder	Spannschraube Screw	TORX PLUS®-Schlüssel TORX PLUS® Wrench
R/LH224.2020.61	4.12T15EP	T15PQ

Einstecken und Längsdrehen (außen)

Grooving and Side Turning (external)



Klemmhalter

Toolholder

H224

mit Schraubklemmung
with screwed clamping

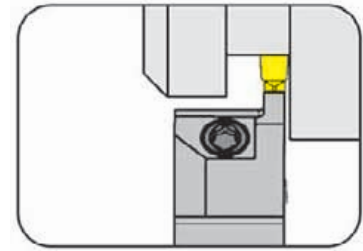

Stechtiefe bis
Spannbereich

Depth of groove up to
Clamping range

7 mm
2,0 - 3,7 mm

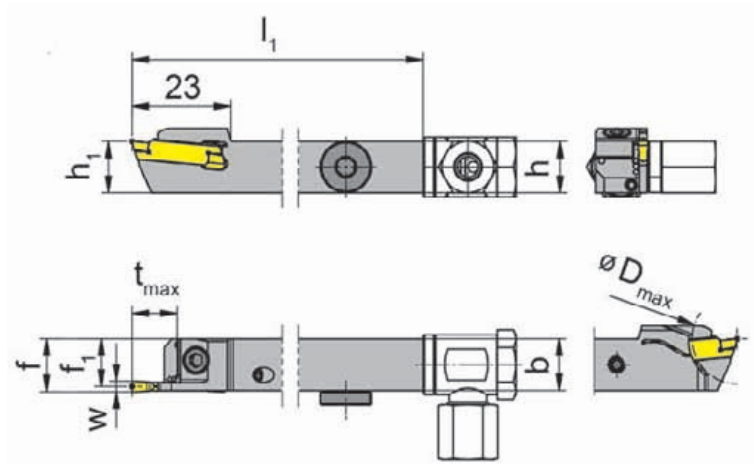

für Wendeschneidplatte
for Indexable insert

Typ S224
Type NS224

mit innerer
Kühlmittelzufuhr
with through coolant supply

R = rechts wie gezeichnet
R = right hand version shown

L = links spiegelbildlich
L = left hand version

Bestellnummer Part number	h	b	l ₁	h ₁	f ₁	f	t _{max}	D _{max}	Größe Size	Spannbereich Clamping range
R/LH224.1212.61.IK	12	12	100	12	0,7	f ₁ +w/2	7	100	01	2,0-2,4
R/LH224.1616.61.IK	16	16	100	16	0,7	f ₁ +w/2	7	100	01	2,0-2,4
R/LH224.2020.61.IK	20	20	100	20	0,7	f ₁ +w/2	7	100	01	2,0-2,4
R/LH224.1212.62.IK	12	12	100	12	0,9	f ₁ +w/2	7	100	02	2,4-2,8
R/LH224.1616.62.IK	16	16	100	16	0,9	f ₁ +w/2	7	100	02	2,4-2,8
R/LH224.2020.62.IK	20	20	100	20	0,9	f ₁ +w/2	7	100	02	2,4-2,8
R/LH224.1212.63.IK	12	12	100	12	1,1	f ₁ +w/2	7	100	03	2,8-3,7
R/LH224.1616.63.IK	16	16	100	16	1,1	f ₁ +w/2	7	100	03	2,8-3,7
R/LH224.2020.63.IK	20	20	100	20	1,1	f ₁ +w/2	7	100	03	2,8-3,7

Ausführung R oder L angeben
State R or L version

w siehe WSP
w see indexable inserts

Abmessungen in mm
Dimensions in mm

Weitere Abmessungen auf Anfrage
Further sizes upon request

Das Anzugsdrehmoment der Schrauben finden Sie in den Technischen Hinweisen.
For torque specification of the screw, please see Technical Instructions.

Ersatzteile

Spare Parts

Klemmhalter Toolholder	Spannschraube Screw	Kühlmittelanschluss Coolant supply	TORX PLUS®-Schlüssel TORX PLUS® Wrench	Dichtstopfen Sealing plug
R/LH224.1212.61.IK	4.12T15EP	004.00.61	T15PQ	
R/LH224...	4.12T15EP	004.00.16	T15PQ	004.00.26

Einstecken und Längsdrehen (außen)

Grooving and Side Turning (external)



Klemmhalter

Toolholder

H224

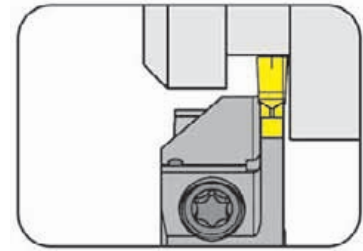

Stechtiefe bis Spannbereich	Depth of groove up to Clamping range	10,5 mm 2,0 - 3,7 mm
--------------------------------	---	-------------------------

für Wendeschneidplatte
for Indexable insert

Typ S224
Type NS224

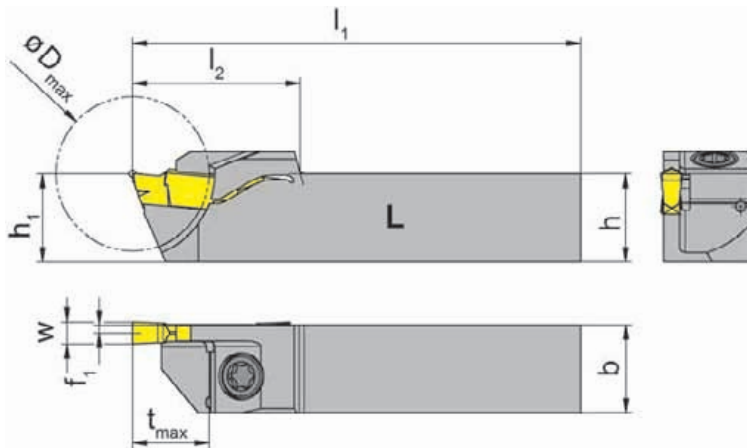

L = links wie gezeichnet
L = left hand version shown

R = rechts spiegelbildlich
R = right hand version

Bestellnummer Part number	h	b	l ₁	l ₂	h ₁	f ₁	t _{max}	D _{max}	Größe Size	Spannbereich Clamping range
R/LH224.1212.20.61	12	12	100	23	12	0,7	10,5	21	01	2,0-2,4
R/LH224.1212.20.62	12	12	100	23	12	0,9	10,5	21	02	2,4-2,8
R/LH224.1212.20.63	12	12	100	23	12	1,1	10,5	21	03	2,8-3,7

Ausführung R oder L angeben
State R or L version

w siehe WSP
w see indexable inserts

Abmessungen in mm
Dimensions in mm

Weitere Abmessungen auf Anfrage
Further sizes upon request

Das Anzugsdrehmoment der Schrauben finden Sie in den Technischen Hinweisen.
For torque specification of the screw, please see Technical Instructions.

Ersatzteile

Spare Parts

Klemmhalter Toolholder	Spannschraube Screw	TORX PLUS®-Schlüssel TORX PLUS® Wrench
R/LH224...	4.12T15EP	T15PQ

Einstecken und Längsdrehen (außen)

Grooving and Side Turning (external)



Klemmhalter

Toolholder

H224

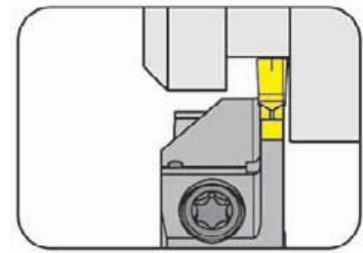

Stechtiefe bis Spannbereich	Depth of groove up to Clamping range	10,5 mm 2,0 - 3,7 mm
--------------------------------	---	-------------------------

für Wendeschneidplatte
for Indexable insert

Typ S224
Type NS224

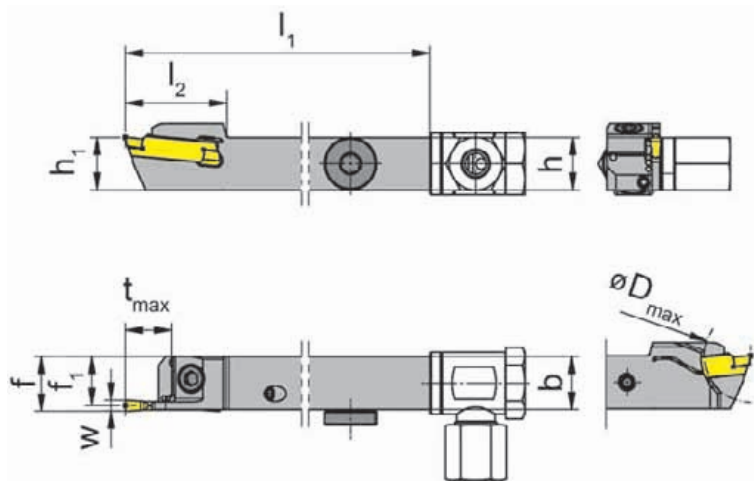

R = rechts wie gezeichnet
R = right hand version shown

L = links spiegelbildlich
L = left hand version

mit innerer
Kühlmittelzufuhr
with through coolant supply

Bestellnummer Part number	h	b	l ₁	l ₂	h ₁	f ₁	f	t _{max}	D _{max}	Größe Size	Spannbereich Clamping range
R/LH224.1212.20.61.IK	12	12	100	23	12	0,7	f ₁ +w/2	10,5	21	01	2,0-2,4
R/LH224.1212.20.62.IK	12	12	100	23	12	0,9	f ₁ +w/2	10,5	21	02	2,4-2,8
R/LH224.1212.20.63.IK	12	12	100	23	12	1,1	f ₁ +w/2	10,5	21	03	2,8-3,7

Ausführung R oder L angeben
State R or L version

w siehe WSP
w see indexable inserts

Abmessungen in mm
Dimensions in mm

Weitere Abmessungen auf Anfrage
Further sizes upon request

Das Anzugsdrehmoment der Schrauben finden Sie in den Technischen Hinweisen.
For torque specification of the screw, please see Technical Instructions.

Ersatzteile

Spare Parts

Klemmhalter Toolholder	Spannschraube Screw	TORX PLUS®-Schlüssel TORX PLUS® Wrench	Kühlmittelanschluss Coolant supply
R/LH224...	4.12T15EP	T15PQ	004.00.61

Einstecken und Längsdrehen (außen)

Grooving and Side Turning (external)



Klemmhalter

Toolholder

H224

mit Schraubklemmung
with screwed clamping

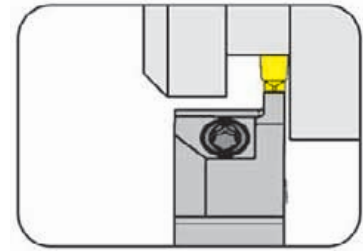

Stechtiefe bis
Spannbereich

Depth of groove up to
Clamping range

7,0 mm
4,4 - 6,1 mm

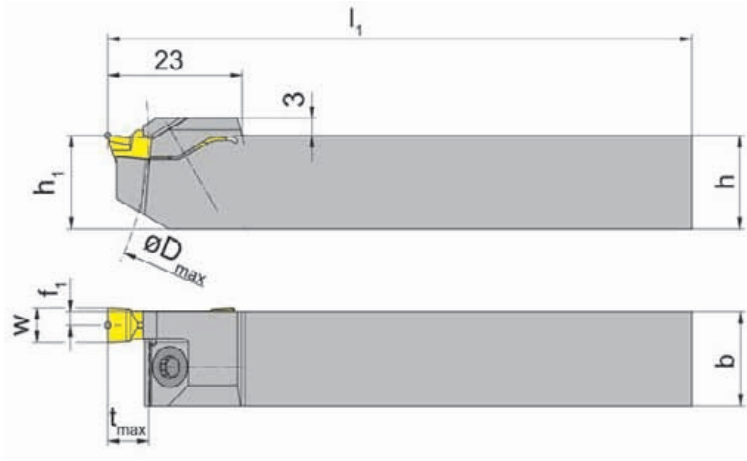

für Wendeschneidplatte
for Indexable insert

Typ S224
Type NS224

L = links wie gezeichnet
L = left hand version shown

R = rechts spiegelbildlich
R = right hand version

Bestellnummer Part number	h	b	l ₁	h ₁	f ₁	t _{max}	D _{max}	Größe Size	Spannbereich Clamping range
R/LH224.1616.65	16	16	100	16	1,85	7	100	05	4,4-5,1
R/LH224.2020.65	20	20	100	20	1,85	7	100	05	4,4-5,1
R/LH224.1616.66	16	16	100	16	2,25	7	100	06	5,1-6,1
R/LH224.2020.66	20	20	100	20	2,25	7	100	06	5,1-6,1

Ausführung R oder L angeben
State R or L version

w siehe WSP
w see indexable inserts

Abmessungen in mm
Dimensions in mm

Weitere Abmessungen auf Anfrage
Further sizes upon request

Das Anzugsdrehmoment der Schrauben finden Sie in den Technischen Hinweisen.
For torque specification of the screw, please see Technical Instructions.

Ersatzteile

Spare Parts

Klemmhalter Toolholder	Spannschraube Screw	TORX PLUS®-Schlüssel TORX PLUS® Wrench
R/LH224...	5.13T20EP	T20PQ

Eckenfreistechen (außen)

Grooving Corner Reliefs (external)



Klemmhalter

Toolholder

H224

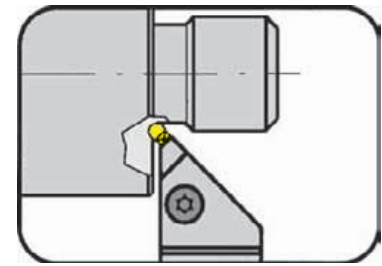

Schneidbreite	Width of groove	2,0 - 6,1 mm
---------------	-----------------	--------------

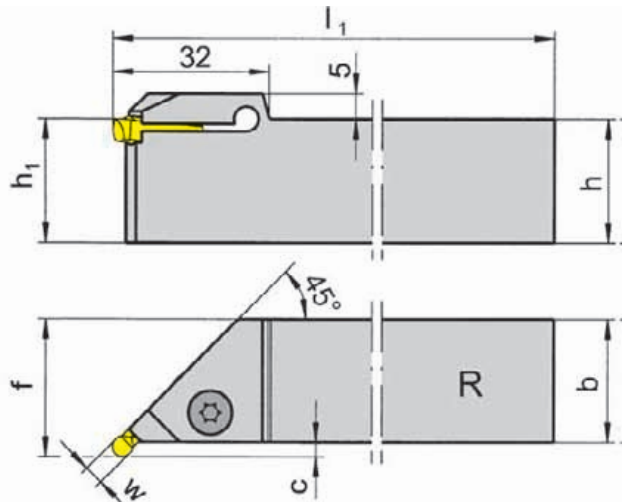

R = rechts wie gezeichnet
R = right hand version shown

L = links spiegelbildlich
L = left hand version

für Wendeschneidplatte
for Indexable insert

Typ S224...K
Type NS224

nur für Vollradius-WSP
S224...K
only for full radius inserts
S224...K

Bestellnummer Part number	h	b	h ₁	l ₁	f	c	Größe Size	Schneidbreite Width of groove
R/LH224.4520.02	20	20	20	125	23,0	2,5	02	2,0-2,8
R/LH224.4525.02	25	25	25	150	28,0	2,5	02	2,0-2,8
R/LH224.4520.04	20	20	20	125	23,0	2,5	04	2,8-4,4
R/LH224.4525.04	25	25	25	150	28,0	2,5	04	2,8-4,4
R/LH224.4520.06	20	20	20	125	23,5	3,0	06	4,4-6,1
R/LH224.4525.06	25	25	25	150	28,5	3,0	06	4,4-6,1

Ausführung R oder L angeben
State R or L version

w und D_{min} siehe WSP
w and D_{min} see indexable inserts

Abmessungen in mm
Dimensions in mm

Weitere Abmessungen auf Anfrage
Further sizes upon request

Das Anzugsdrehmoment der Schrauben finden Sie in den Technischen Hinweisen.
For torque specification of the screw, please see Technical Instructions.

Korrektur-Faktoren Δl_1 , Δc und Δf im Verhältnis zum Radius r
Revision factor Δl_1 , Δc and Δf in relation to radius r

r	Δl_1	Δc	Δf
3,0	0	0	0
2,5	-0,146	-0,146	-0,146
2,0	0	0	0
1,5	-0,146	-0,146	-0,146
1,0	0	0	0

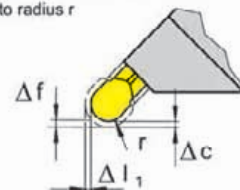

Ersatzteile

Spare Parts

Klemmhalter Toolholder	Spannschraube Screw	TORX PLUS®-Schlüssel TORX PLUS® Wrench
R/LH224...	6.23T25P	T25PQ

Einstechen und Abstechen

Grooving and Parting Off



Klemmhalter

Toolholder

H224

mit Selbstklemmung
with self clamping

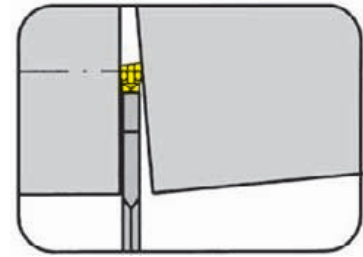

Stechtiefe bis Spannbereich	Depth of groove up to Clamping range	18 mm 2,4 - 3,7 mm
--------------------------------	---	-----------------------

für Wendeschneidplatte
for Indexable insert

Typ S224
Type NS224

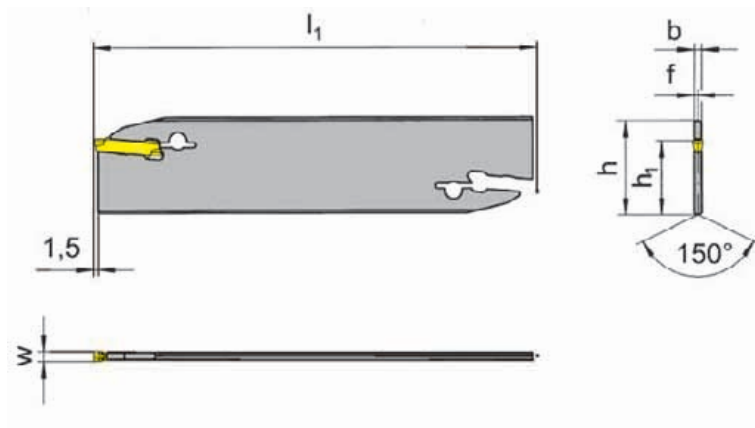

Bestellnummer Part number	h	b	l ₁	h ₁	f	t _{max}	Größe Size	Spannbereich Clamping range
H224.2602.02	26	1,9	110	21,4	0,95	18	02	2,4-2,8
H224.2603.03	26	2,3	110	21,4	1,15	18	03	2,8-3,7
H224.3203.03	32	2,3	150	24,8	1,15	18	03	2,8-3,7

Weitere Abmessungen auf Anfrage
Further sizes upon request

w siehe WSP
w see indexable inserts

Abmessungen in mm
Dimensions in mm

Hinweis:

Der Schlüssel **P39L** gehört nicht zum Lieferumfang des Schneidträgers. Bitte separat bestellen!

Note:

Wrench **P39L** ist not combined with blade - separate order required!

G

Einstechen und Abstechen

Grooving and Parting Off



Klemmhalter

Toolholder

H224

verstärkte Ausführung
reinforced version

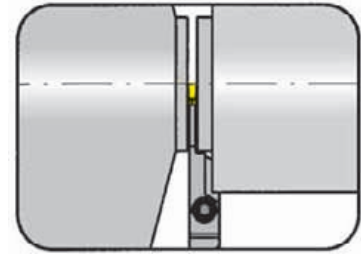

Stechtiefe bis
Spannbereich

Depth of groove up to
Clamping range

18 mm
2,4 - 3,7 mm

für TRAUB-Maschinen (TNK28/TNK36/TNL26)
for machines TRAUB (TNK28/TNK36/TNL26)

für Wendeschneidplatte
for Indexable insert

Typ S224
Type NS224

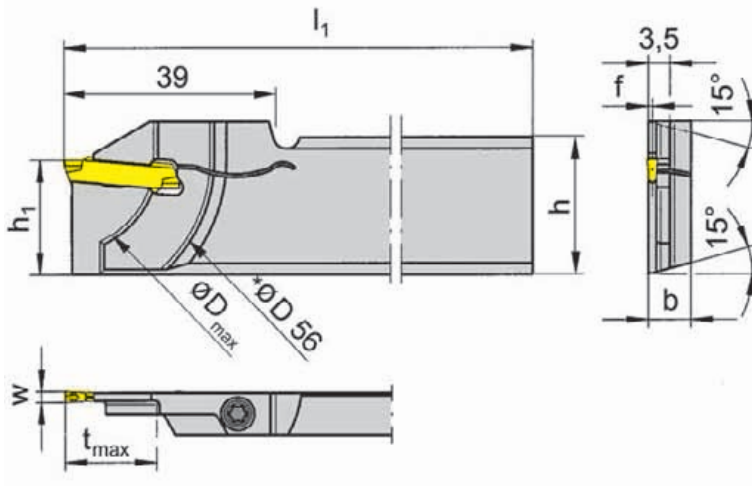

R = rechts wie gezeichnet
R = right hand version shown

L = links spiegelbildlich
L = left hand version

Bestellnummer Part number	h	b	l_1	h_1	f	t_{max}	D_{max}	Größe Size	Spannbereich Clamping range
R/LH224.2608.81	26	7,9	110	21,4	0,75	18	36	01	2,0-2,4
R/LH224.2608.82	26	7,9	110	21,4	0,95	18	36	02	2,4-2,8
R/LH224.2608.83	26	7,9	110	21,4	1,10	18	36	03	2,8-3,7

Ausführung R oder L angeben
State R or L version

w siehe WSP
w see indexable inserts

Abmessungen in mm
Dimensions in mm

*D 56 = D_{max} der Gegenspindel
*D 56 = D_{max} of the subspindle

Weitere Abmessungen auf Anfrage
Further sizes upon request

Das Anzugsdrehmoment der Schrauben finden Sie in den Technischen Hinweisen.
For torque specification of the screw, please see Technical Instructions.

Ersatzteile

Spare Parts

Klemmhalter Toolholder	Spannschraube Screw	TORX PLUS®-Schlüssel TORX PLUS® Wrench
R/LH224.2608....	4.15T15P	T15PQ

Einstechen und Abstechen

Grooving and Parting Off



Klemmhalter

Toolholder

H224

verstärkte Ausführung
reinforced version

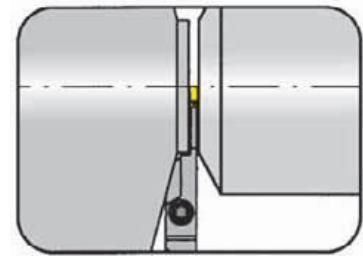

Stechtiefe bis Spannbereich	Depth of groove up to Clamping range	21 mm 2,0 - 3,7 mm
--------------------------------	---	-----------------------

für TRAUB-Maschinen (TNK28/TNK36/TNL26)
for machines TRAUB (TNK28/TNK36/TNL26)

für Wendeschneidplatte
for Indexable insert

Typ S224
Type NS224

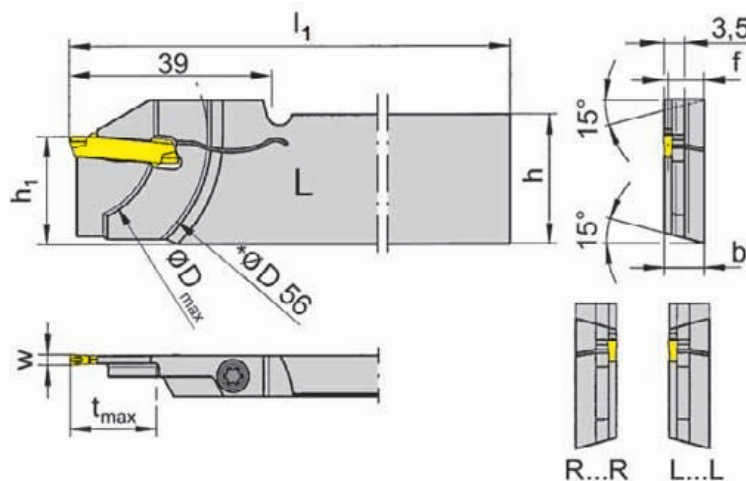

L = links wie gezeichnet
L = left hand version shown

R = rechts spiegelbildlich
R = right hand version

Bestellnummer Part number	h	b	l ₁	h ₁	f	t _{max}	D _{max}	Größe Size	Spannbereich Clamping range
LH224.2608.81L	26	7,9	110	21,4	7,15	18	36	01	2,0-2,4
RH224.2608.81R	26	7,9	110	21,4	7,15	18	36	01	2,0-2,4
LH224.2608.82L	26	7,9	110	21,4	6,95	18	36	02	2,4-2,8
RH224.2608.82R	26	7,9	110	21,4	6,95	18	36	02	2,4-2,8
LH224.2608.83L	26	7,9	110	21,4	6,75	18	36	03	2,8-3,7
RH224.2608.83R	26	7,9	110	21,4	6,75	18	36	03	2,8-3,7
RH224.3208.83R	32	7,9	110	24,8	6,80	21	42	03	2,8-3,7

Ausführung R oder L angeben
State R or L version

w siehe WSP
w see indexable inserts

Abmessungen in mm
Dimensions in mm

Weitere Abmessungen auf Anfrage
Further sizes upon request

*D 56 = D_{max} der Gegenspindel

*D 56 = D_{max} of the subspindle

* Bei besonderer Spannsituation auf der Gegenspindel (z.B. HAINBUCH Axfixfutter usw.)

* For specific clamping device on subspindle (e.g. HAINBUCH Axfixchuck)

Das Anzugsdrehmoment der Schrauben finden Sie in den Technischen Hinweisen.

For torque specification of the screw, please see Technical Instructions.

Ersatzteile

Spare Parts

Klemmhalter Toolholder	Spannschraube Screw	TORX PLUS®-Schlüssel TORX PLUS® Wrench
R/LH224...	4.15T15P	T15PL
R/LH224.3208.83R/L	5.13 T20P	T20PQ

Einstechen und Abstechen

Grooving and Parting Off



Klemmhalter

Toolholder

H224

verstärkte Ausführung
reinforced version

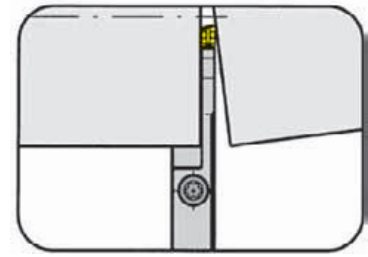

Stechtiefe bis Spannbereich	Depth of groove up to Clamping range	18 mm 2,0 - 3,7 mm
--------------------------------	---	-----------------------

für Wendeschneidplatte
for Indexable insert

Typ S224
Type NS224

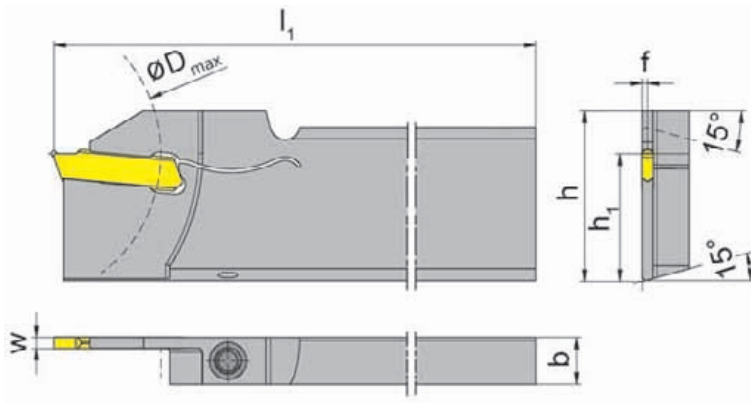

R = rechts wie gezeichnet
R = right hand version shown

L = links spiegelbildlich
L = left hand version

Bestellnummer Part number	h	b	l_1	h_1	f	t_{max}	D_{max}	Größe Size	Spannbereich Clamping range
R/LH224.2608.01	26	7,9	110	21,4	0,7	18	50	01	2,0-2,4
R/LH224.3208.01	32	7,9	110	24,8	0,7	18	50	01	2,0-2,4
R/LH224.2608.02	26	7,9	110	21,4	0,9	18	50	02	2,4-2,8
R/LH224.3208.02	32	7,9	110	24,8	0,9	18	50	02	2,4-2,8
R/LH224.2608.03	26	7,9	110	21,4	1,1	18	50	03	2,8-3,7
R/LH224.3208.03	32	7,9	110	24,8	1,1	18	50	03	2,8-3,7

Ausführung R oder L angeben
State R or L version

w siehe WSP
w see indexable inserts

Abmessungen in mm
Dimensions in mm

Weitere Abmessungen auf Anfrage
Further sizes upon request

Das Anzugsdrehmoment der Schrauben finden Sie in den Technischen Hinweisen.
For torque specification of the screw, please see Technical Instructions.

Abstechen von Wellen
parting off solid bars

Abstechen von Ringen
parting off tubes

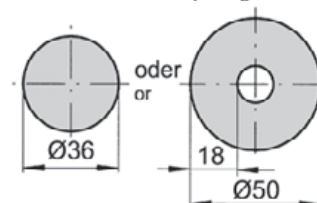

Ersatzteile

Spare Parts

Klemmhalter Toolholder	Spannschraube Screw	TORX PLUS®-Schlüssel TORX PLUS® Wrench
R/LH224...	4.20T15P	T15PQ

Einstecken und Abstechen

Grooving and Parting Off



Klemmhalter

Toolholder

H224

mit Schraubklemmung
with screwed clamping

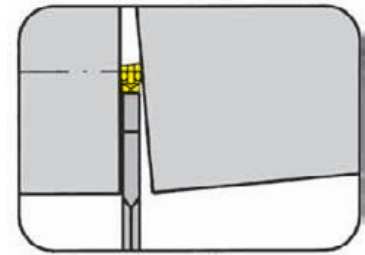

Stechtiefe bis Spannbereich	Depth of groove up to Clamping range	32,5 mm 3,7 mm
--------------------------------	---	-------------------

für Wendeschneidplatte
for Indexable insert

Typ S224
Type NS224

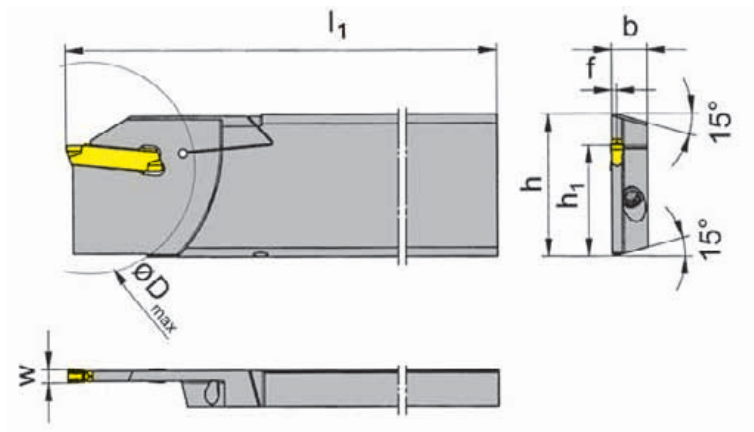

R = rechts wie gezeichnet
R = right hand version shown

L = links spiegelbildlich
L = left hand version

Bestellnummer Part number	h	b	l ₁	h ₁	f	t _{max}	D _{max}	Größe Size	Spannbereich Clamping range
R/LH224.3208.93	32	8	112	24,8	1,15	32,5	65	03	2,8-3,7

Ausführung R oder L angeben
State R or L version

w siehe WSP
w see indexable inserts

Abmessungen in mm
Dimensions in mm

Weitere Abmessungen auf Anfrage
Further sizes upon request

Das Anzugsdrehmoment der Schrauben finden Sie in den Technischen Hinweisen.
For torque specification of the screw, please see Technical Instructions.

Ersatzteile

Spare Parts

Klemmhalter Toolholder	Spannschraube Screw	TORX PLUS®-Schlüssel TORX PLUS® Wrench
R/LH224.3208.93	030.0413.T15P	T15PQ

Einstecken und Längsdrehen (innen)

Grooving and Side Turning (internal)



Klemmhalter

Toolholder

B224

Kurzausführung
Short Version

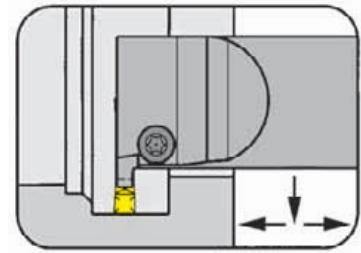

Bohrungs-Ø ab
Stechtiefe bis
Spannbereich

Bore Ø from
Depth of groove up to
Clamping range

30 mm
8 mm
2,0 - 6,1 mm

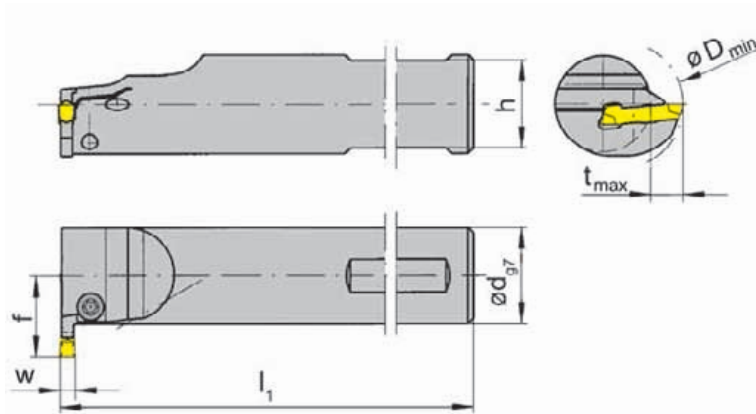

für Wendeschneidplatte
for Indexable insert

Typ S224
Type NS224

mit innerer
Kühlmittelzufuhr
with through coolant supply

R = rechts wie gezeichnet
R = right hand version shown

L = links spiegelbildlich
L = left hand version

Bestellnummer Part number	d	l ₁	h	t _{max}	D _{min}	f	Größe Size	Spannbereich Clamping range
R/LB224.0020.0.01	20	130	18	8	30	18,5	01	2,0-2,4
R/LB224.0025.0.01	25	130	23	8	35	21,0	01	2,0-2,4
R/LB224.0020.0.02	20	130	18	8	30	18,5	02	2,4-2,8
R/LB224.0025.0.02	25	130	23	8	35	21,0	02	2,4-2,8
R/LB224.0020.0.03	20	130	18	8	30	18,5	03	2,8-3,7
R/LB224.0025.0.03	25	130	23	8	35	21,0	03	2,8-3,7
R/LB224.0032.0.03	32	150	30	8	42	24,5	03	2,8-3,7
R/LB224.0020.0.04	20	130	18	8	30	18,5	04	3,7-4,4
R/LB224.0025.0.04	25	130	23	8	35	21,0	04	3,7-4,4
R/LB224.0032.0.04	32	150	30	8	42	24,5	04	3,7-4,4
R/LB224.0020.0.05	20	130	18	8	30	18,5	05	4,4-5,1
R/LB224.0025.0.05	25	130	23	8	35	21,0	05	4,4-5,1
R/LB224.0032.0.05	32	150	30	8	42	24,5	05	4,4-5,1
R/LB224.0025.0.06	25	130	23	8	35	21,0	06	5,1-6,1
R/LB224.0032.0.06	32	150	30	8	42	24,5	06	5,1-6,1

Ausführung R oder L angeben
State R or L version

w siehe WSP
w see indexable inserts

Abmessungen in mm
Dimensions in mm

Weitere Abmessungen auf Anfrage
Further sizes upon request

Das Anzugsdrehmoment der Schrauben finden Sie in den Technischen Hinweisen.
For torque specification of the screw, please see Technical Instructions.

Ersatzteile

Spare Parts

Klemmhalter Toolholder	Spannschraube Screw	TORX PLUS®-Schlüssel TORX PLUS® Wrench
R/LB224...	5.13T20EP	T20PQ

Einstecken und Längsdrehen (innen)

Grooving and Side Turning (internal)



Klemmhalter

Toolholder

B224

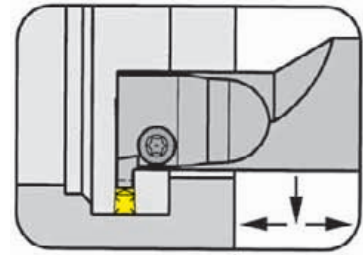

Bohrungs-Ø ab
Stechtiefe bis
Spannbereich

Bore Ø from
Depth of groove up to
Clamping range

28 mm
8 mm
2,0 - 6,1 mm

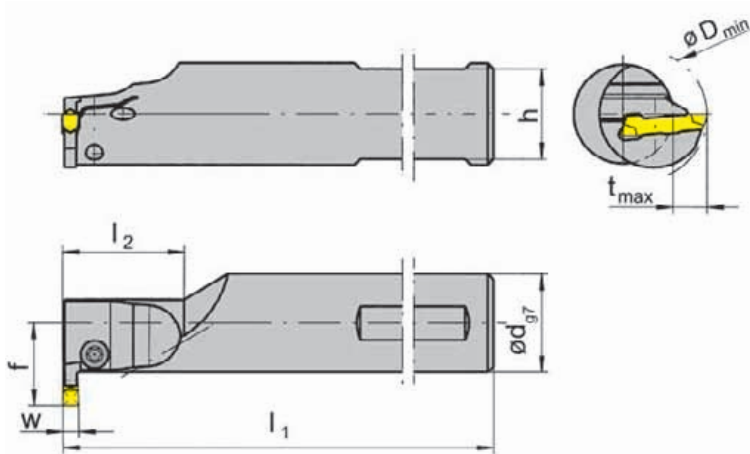

für Wendeschneidplatte
for Indexable insert

Typ S224
Type NS224

mit innerer
Kühlmittelzufuhr
with through coolant supply

R = rechts wie gezeichnet
R = right hand version shown

L = links spiegelbildlich
L = left hand version

Bestellnummer Part number	d	l ₁	h	t _{max}	l ₂	D _{min}	f	Größe Size	Spannbereich Clamping range
R/LB224.0020.1.01	20	130	18	8	30	28	18,5	01	2,0-2,4
R/LB224.0025.1.01	25	130	23	8	30	28	21,0	01	2,0-2,4
R/LB224.0020.1.02	20	130	18	8	30	28	18,5	02	2,4-2,8
R/LB224.0025.1.02	25	130	23	8	30	28	21,0	02	2,4-2,8
R/LB224.0020.1.03	20	130	18	8	30	28	18,5	03	2,8-3,7
R/LB224.0025.1.03	25	130	23	8	30	28	21,0	03	2,8-3,7
R/LB224.0032.1.03	32	150	30	8	30	28	24,5	03	2,8-3,7
R/LB224.0020.1.04	20	130	18	8	30	28	18,5	04	3,7-4,4
R/LB224.0025.1.04	25	130	23	8	30	28	21,0	04	3,7-4,4
R/LB224.0032.1.04	32	150	30	8	30	28	24,5	04	3,7-4,4
R/LB224.0025.1.05	25	130	23	8	30	28	21,0	05	4,4-5,1
R/LB224.0032.1.05	32	150	30	8	30	28	24,5	05	4,4-5,1
R/LB224.0025.1.06	25	130	23	8	30	28	21,0	06	5,1-6,1
R/LB224.0032.1.06	32	150	30	8	30	28	24,5	06	5,1-6,1

Ausführung R oder L angeben
State R or L version

w siehe WSP
w see indexable inserts

Abmessungen in mm
Dimensions in mm

Weitere Abmessungen auf Anfrage
Further sizes upon request

Das Anzugsdrehmoment der Schrauben finden Sie in den Technischen Hinweisen.
For torque specification of the screw, please see Technical Instructions.

Ersatzteile

Spare Parts

Klemmhalter Toolholder	Spannschraube Screw	TORX PLUS®-Schlüssel TORX PLUS® Wrench
R/LB224...	5.13T20EP	T20PQ

Einstecken und Längsdrehen (innen)

Grooving and Side Turning (internal)



Klemmhalter

Toolholder

B224

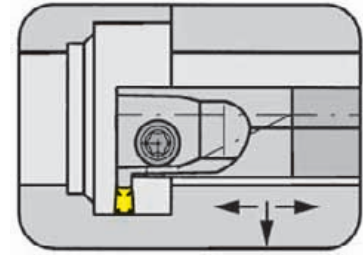

Bohrungs-Ø ab	Bore Ø from	32 mm
Stechtiefe bis	Depth of groove up to	13 mm
Spannbereich	Clamping range	2,8 - 6,1 mm

für Wendeschneidplatte
for Indexable insert

Typ S224
Type NS224

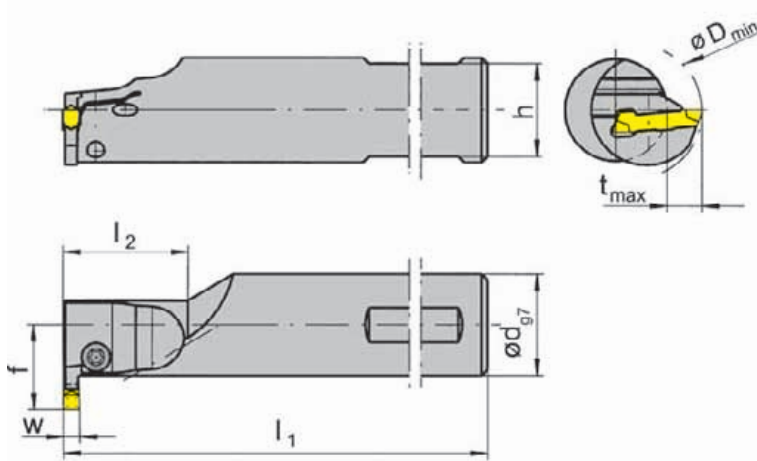

R = rechts wie gezeichnet
R = right hand version shown

L = links spiegelbildlich
L = left hand version

mit innerer
Kühlmittelezufuhr
with through coolant supply

Bestellnummer Part number	d	l ₁	h	t _{max}	l ₂	D _{min}	f	Größe Size	Spannbereich Clamping range
R/LB224.0025.1.13	25	130	23	10	30	32	23,5	03	2,8-3,7
R/LB224.0032.1.13	32	150	30	11	30	32	28,0	03	2,8-3,7
R/LB224.0025.1.14	25	130	23	10	30	32	23,5	04	3,7-4,4
R/LB224.0032.1.14	32	150	30	11	30	32	28,0	04	3,7-4,4
R/LB224.0032.1.15	32	150	30	11	30	32	28,0	05	4,4-5,1
R/LB224.0040.1.25	40	180	38	13	30	38	34,0	05	4,4-5,1
R/LB224.0032.1.16	32	150	30	11	30	32	28,0	06	5,1-6,1
R/LB224.0040.1.26	40	180	38	13	30	38	34,0	06	5,1-6,1

Ausführung R oder L angeben
State R or L version

w siehe WSP
w see indexable inserts

Abmessungen in mm
Dimensions in mm

Weitere Abmessungen auf Anfrage
Further sizes upon request

Das Anzugsdrehmoment der Schrauben finden Sie in den Technischen Hinweisen.
For torque specification of the screw, please see Technical Instructions.

Ersatzteile

Spare Parts

Klemmhalter Toolholder	Spannschraube Screw	TORX PLUS®-Schlüssel TORX PLUS® Wrench
R/LB224...	5.13T20EP	T20PQ

Einstecken und Längsdrehen (innen)

Grooving and Side Turning (internal)



Klemmhalter

Toolholder

B224

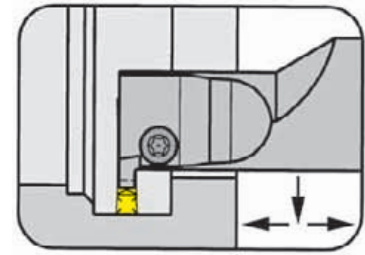

Bohrungs-Ø ab	Bore Ø from	28 mm
Stechtiefe bis	Depth of groove up to	11 mm
Spannbereich	Clamping range	2,0 - 4,4 mm

für Wendeschneidplatte
for Indexable insert

Typ S224
Type NS224

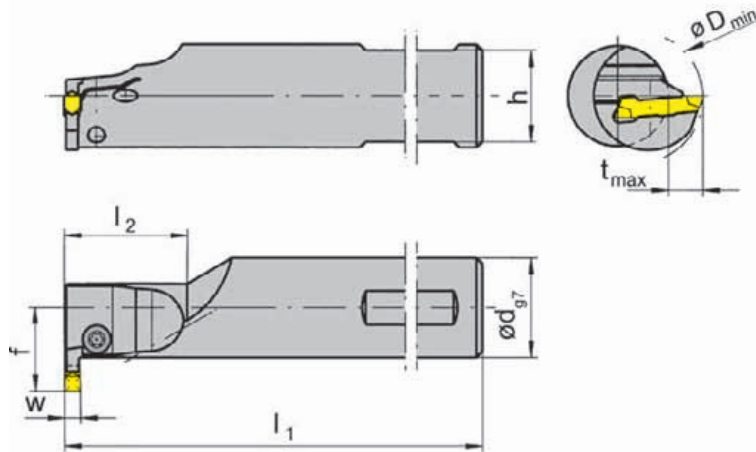

R = rechts wie gezeichnet
R = right hand version shown

L = links spiegelbildlich
L = left hand version

mit innerer
Kühlmittelzufuhr
with through coolant supply

Bestellnummer Part number	d	l ₁	h	t _{max}	l ₂	D _{min}	f	Größe Size	Spannbereich Clamping range
R/LB224.0020.2.01	20	130	18	8	45	28	18,5	01	2,0-2,4
R/LB224.0025.2.01	25	150	23	8	50	28	21,0	01	2,0-2,4
R/LB224.0020.2.02	20	130	18	8	45	28	18,5	02	2,4-2,8
R/LB224.0025.2.02	25	150	23	8	50	28	21,0	02	2,4-2,8
R/LB224.0025.2.03	25	150	23	8	50	28	21,0	03	2,8-3,7
R/LB224.0032.2.03	32	180	30	8	50	28	24,5	03	2,8-3,7
R/LB224.0032.2.13	32	180	30	11	50	32	28,0	03	2,8-3,7
R/LB224.0025.2.04	25	150	23	8	50	28	21,0	04	3,7-4,4
R/LB224.0032.2.04	32	180	30	8	50	28	24,5	04	3,7-4,4
R/LB224.0032.2.14	32	180	30	11	50	32	28,0	04	3,7-4,4

Ausführung R oder L angeben
State R or L version

w siehe WSP
w see indexable inserts

Abmessungen in mm
Dimensions in mm

Weitere Abmessungen auf Anfrage
Further sizes upon request

Das Anzugsdrehmoment der Schrauben finden Sie in den Technischen Hinweisen.
For torque specification of the screw, please see Technical Instructions.

Ersatzteile

Spare Parts

Klemmhalter Toolholder	Spannschraube Screw	TORX PLUS®-Schlüssel TORX PLUS® Wrench
R/LB224...	5.13T20EP	T20PQ

Einstecken und Längsdrehen (innen)

Grooving and Side Turning (internal)



Grundhalter

Basic toolholder

B224

ohne Kassette
without cassette

Bohrungs-Ø ab	Bore Ø from	40 mm
Stechtiefe bis	Depth of groove up to	11 mm
Spannbereich	Clamping range	2,0 - 6,1 mm

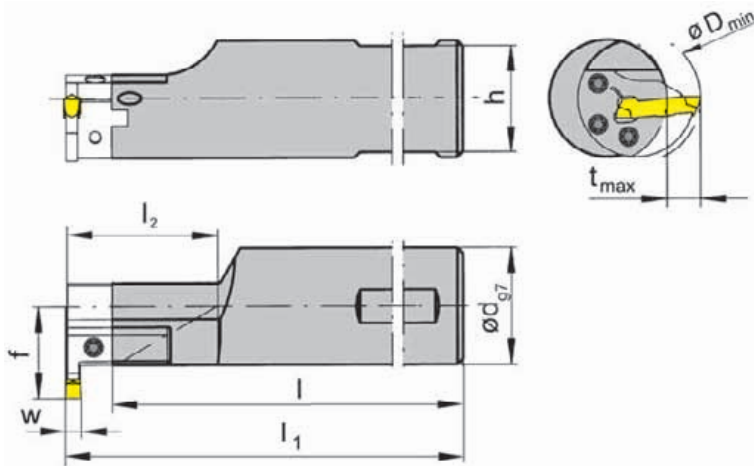
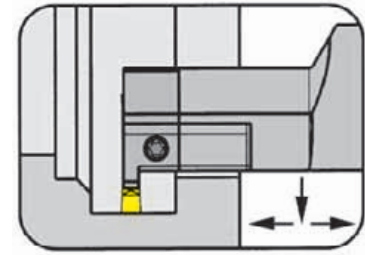

für Kassette
for Cassette

Typ BK224
Type

mit innerer
Kühlmittelzufuhr
with through coolant supply

R = rechts wie gezeichnet
R = right hand version shown

L = links spiegelbildlich
L = left hand version

Bestellnummer Part number	d	l	l ₂	h	l ₁	f
R/LB224.0032.1.K2	32	136,3	30	30	l+b ₁ +w/2	28
R/LB224.0032.2.K2	32	166,3	60	30	l+b ₁ +w/2	28
R/LB224.0040.1.K2	40	166,3	30	38	l+b ₁ +w/2	32
R/LB224.0040.2.K2	40	186,3	60	38	l+b ₁ +w/2	32

Ausführung R oder L angeben
State R or L version

w siehe WSP
w see indexable inserts

Abmessungen in mm
Dimensions in mm

Weitere Abmessungen auf Anfrage
Further sizes upon request

Hinweis:

Abmessungen für D_{min}, t_{max} und b₁ siehe Kassetten

Note:

Dimensions for D_{min}, t_{max} and b₁ see cassettes

Ersatzteile

Spare Parts

Grundhalter Basic toolholder	Spannschraube Screw	TORX PLUS®-Schlüssel TORX PLUS® Wrench
R/LB224...	030.0518T20P	T20PQ

Einstecken und Längsdrehen (innen)

Grooving and Side Turning (internal)



Kassette

Cassette

BK224

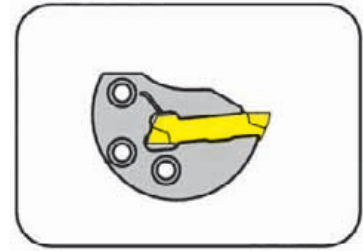

Bohrungs-Ø ab	Bore Ø from	40 mm
Stechtiefe bis	Depth of groove up to	11 mm
Spannbereich	Clamping range	2,0 - 6,1 mm

für Wendeschneidplatte
for Indexable insert

Typ S224
Type NS224

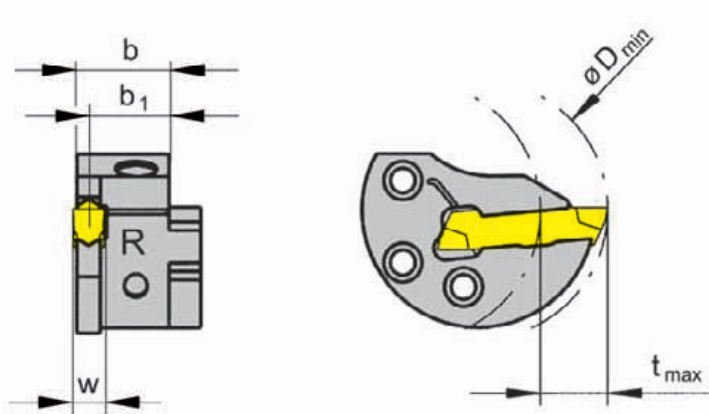

R = rechts wie gezeichnet
R = right hand version shown

L = Linksausführung
L = left hand version

Bestellnummer Part number	b ₁	b	D _{min}	t _{max}	Größe Size	Spannbereich Clamping range
R/LBK224.0040.01	12,70	13,40	40	11	01	2,0-2,4
R/LBK224.0040.02	12,45	13,35	40	11	02	2,4-2,8
R/LBK224.0040.03	12,20	13,30	40	11	03	2,8-3,7
R/LBK224.0040.04	11,70	13,15	40	11	04	3,7-4,4
R/LBK224.0040.05	11,20	13,05	40	11	05	4,4-5,1
R/LBK224.0040.06	10,70	12,95	40	11	06	5,1-6,1

Ausführung R oder L angeben
State R or L version

w siehe WSP
w see indexable inserts

Abmessungen in mm
Dimensions in mm

Rechte Kassetten in rechten und linke Kassetten in linken Grundhaltern verwenden.
Use right hand cassettes in right hand basic toolholders and left hand cassettes in left hand basic toolholders.

Bestellhinweis:

Befestigungsschrauben der Kassetten gehören zum Lieferumfang des Grundhalters.

Ordering note:

The fastening screw is combined with the basic toolholder - no separate order required.

Das Anzugsdrehmoment der Schrauben finden Sie in den Technischen Hinweisen.

For torque specification of the screw, please see Technical Instructions.

Ersatzteile

Spare Parts

Kassette Cassette	Spannschraube Screw	TORX PLUS®-Schlüssel TORX PLUS® Wrench
R/LBK224...	5.13T20EP	T20PQ

Eckenfreistechen (innen)

Grooving Corner Reliefs (internal)



Klemmhalter
Toolholder

224

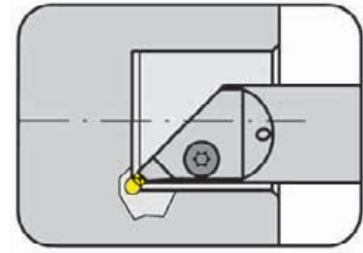

Schneidbreite	Width of groove	2,0 - 6,1 mm
---------------	-----------------	--------------

für Wendeschneidplatte
for Indexable insert

Typ S224
Type

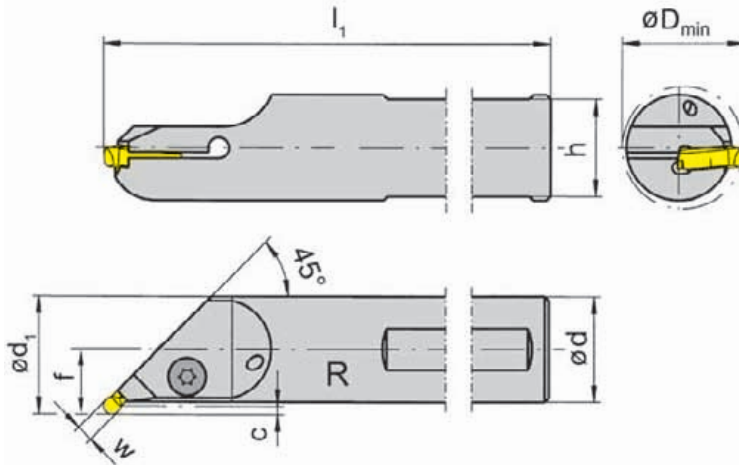

R = rechts wie gezeichnet
R = right hand version shown

L = links spiegelbildlich
L = left hand version

nur für Vollradius-WSP
S224...K
only for full radius inserts
S224...K

Bestellnummer Part number	d	h	l ₁	f	D _{min}	c	d ₁	Schneidbreite Width of groove
R/LB224.4520.0.02	20	18	130	13,0	25,0	2,5	23,0	2,0-2,8
R/LB224.4525.0.02	25	23	150	15,5	29,0	2,5	28,0	2,0-2,8
R/LB224.4532.0.02	32	30	150	19,0	36,0	2,5	35,0	2,0-2,8
R/LB224.4540.1.02	40	38	200	23,0	44,0	2,5	43,0	2,0-2,8
R/LB224.4520.0.04	20	18	130	13,0	25,0	2,5	23,0	2,8-4,4
R/LB224.4525.0.04	25	23	150	15,5	29,0	2,5	28,0	2,8-4,4
R/LB224.4532.0.04	32	30	150	19,0	36,0	2,5	35,0	2,8-4,4
R/LB224.4540.1.04	40	38	200	23,0	44,0	2,5	43,0	2,8-4,4
R/LB224.4520.0.06	20	18	130	13,5	25,0	3,0	23,5	4,4-6,1
R/LB224.4525.0.06	25	23	150	16,0	29,5	3,0	28,5	4,4-6,1
R/LB224.4532.0.06	32	30	150	19,0	36,5	3,0	35,5	4,4-6,1

Ausführung R oder L angeben
State R or L version

w siehe WSP
w see indexable inserts

Abmessungen in mm
Dimensions in mm

Weitere Abmessungen auf Anfrage
Further sizes upon request

Das Anzugsdrehmoment der Schrauben finden Sie in den Technischen Hinweisen.
For torque specification of the screw, please see Technical Instructions.

Korrektur-Faktoren Δl_1 , Δc und Δf im Verhältnis zum Radius r
Revision factor Δl_1 , Δc and Δf in relation to radius r

r	Δl_1	Δc	Δf
3,0	0	0	0
2,5	-0,146	-0,146	-0,146
2,0	0	0	0
1,5	-0,146	-0,146	-0,146
1,0	0	0	0

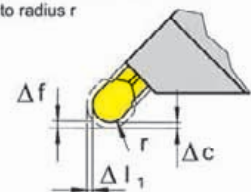

Ersatzteile
Spare Parts

Klemmhalter Toolholder	Spannschraube Screw	TORX PLUS®-Schlüssel TORX PLUS® Wrench
R/LB224...	6.14T25P	T25PQ

Eckenfreistechen (innen)

Grooving Corner Reliefs (internal)



Klemmhalter

Toolholder

224

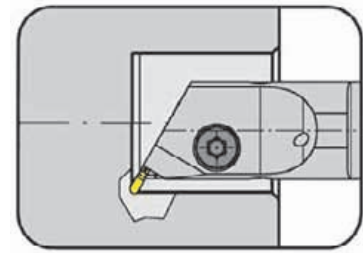

Schneidbreite	Width of groove	2,0 - 6,1 mm
---------------	-----------------	--------------

für Wendeschneidplatte
for Indexable insert

Typ S224
Type

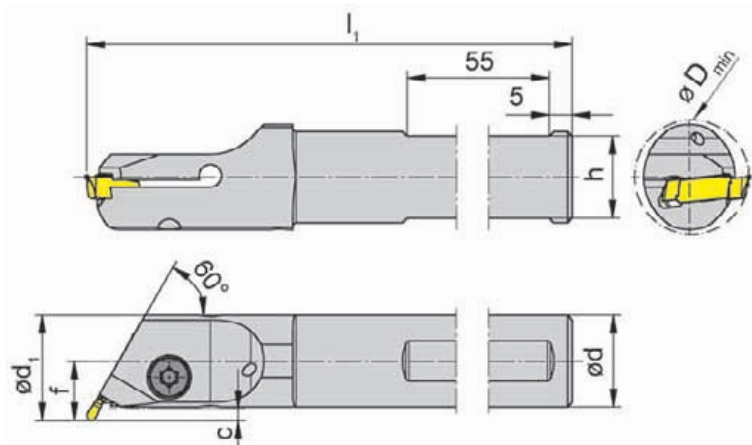

R = rechts wie gezeichnet
R = right hand version shown

L = links spiegelbildlich
L = left hand version

nur für Vollradius-WSP
S224...K
only for full radius inserts
S224...K

Bestellnummer Part number	d	h	l ₁	f	D _{min}	c	d ₁	Schneidbreite Width of groove
R/LB224.6020.0.02	20	18	150	13,0	25,0	2,5	23,0	2,0-2,8
R/LB224.6025.0.02	25	23	150	15,5	29,0	2,5	28,0	2,0-2,8
R/LB224.6032.0.02	32	30	150	19,0	36,0	2,5	35,0	2,0-2,8
R/LB224.6020.0.04	20	18	150	13,0	25,0	2,5	23,0	2,8-4,4
R/LB224.6025.0.04	25	23	150	15,5	29,0	2,5	28,0	2,8-4,4
R/LB224.6032.0.04	32	30	150	19,0	36,0	2,5	35,0	2,8-4,4
R/LB224.6020.0.06	20	18	150	13,5	25,0	3,0	23,5	4,4-6,1
R/LB224.6025.0.06	25	23	150	16,0	29,5	3,0	28,5	4,4-6,1
R/LB224.6032.0.06	32	30	150	19,5	36,5	3,0	35,5	4,4-6,1

Ausführung R oder L angeben
State R or L version

Abmessungen in mm
Dimensions in mm

Weitere Abmessungen auf Anfrage
Further sizes upon request

Das Anzugsdrehmoment der Schrauben finden Sie in den Technischen Hinweisen.
For torque specification of the screw, please see Technical Instructions.

Korrektur-Faktoren Δl_1 , Δc und Δf im Verhältnis zum Radius r
Revision factor Δl_1 , Δc and Δf in relation to radius r

r	Δl_1	Δc	Δf
3,0	0	0	0
2,5	-0,25	-0,067	-0,067
2,0	0	0	0
1,5	-0,25	-0,067	-0,067
1,0	0	0	0

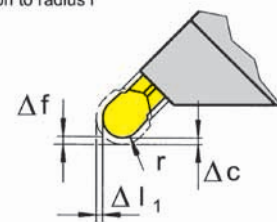

Ersatzteile

Spare Parts

Klemmhalter Toolholder	Spannschraube Screw	TORX PLUS®-Schlüssel TORX PLUS® Wrench
R/LB224...	6.14T25P	T25PQ

Wendeschnidplatte

Indexable insert

S224...3.

präzisionsgesintert
precision sintered



Geometrie .3.

Geometrie mit Spanformrille für alle Werkstoffe.
Geometry with chip forming for all materials.

Hauptmerkmale Characteristics

- sichere Spankontrolle (Spanrolle)
- universell einsetzbar - auch für Werkstoffe mit höherer Festigkeit
- saubere Nutflanken durch Spanformung
- Produktionssicherheit durch kontrollierten Spanablauf

Einsatzgebiete Applications

- Einstechen:
Stechtiefe bis 18 mm
- Längsdrehen:
Schnittiefe a_p bis 3 mm*
- Grooving:
Depth of groove up to 18 mm
- Side turning:
Depth of cut a_p up to 3 mm*

- excellent swarf control
- suitable for high alloy- high strength steels
- reduced swarf width gives high flank surface finish
- excellent swarf control allows production security

Vorschub f Feed rate f

- Einstechen: 0,15 bis 0,25 mm/U*
- Längsdrehen: bis 0,4 mm/U*
- Grooving: 0,15 up to 0,25 mm/rev*
- Side turning: up to 0,4 mm/rev*

* abhängig von der Plattenbreite
* dependent upon width of insert

Formwendeschnidplatten, Zwischenmaße oder andere Eckenradien sind auf Anfrage erhältlich!
Wendeschnidplatten sind in **rechten und linken** Klemmhaltern verwendbar.

Indexable inserts with profiles, intermediate sizes or other edge radii are available upon request.
Indexable inserts can be used in **right and left hand** toolholders.

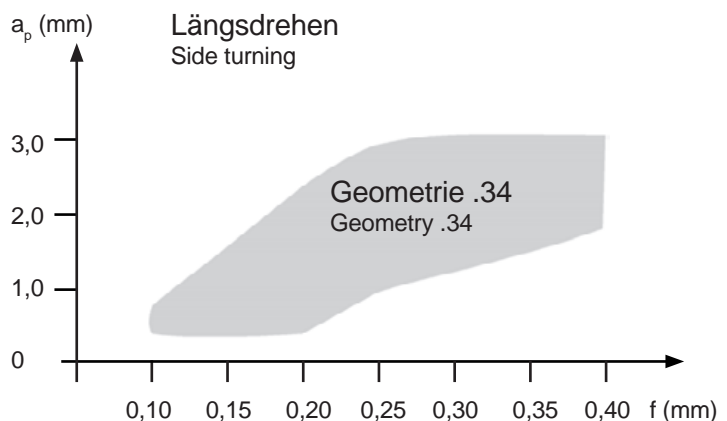

Spanbruchdiagramm S224.0500.34, Werkstoff 16MnCr5
Chip control graph S224.0500.34 material 16MnCr5

Einstechen und Längsdrehen

Grooving and Side Turning



Wendeschneidplatte

Indexable insert

S224

mit Spanformrille
with chip former

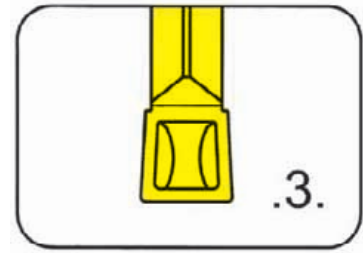

Stechtiefe bis Stechbreite	Depth of groove up to Width of groove	18 mm 3-6 mm
-------------------------------	--	-----------------

präzisionsgesintert
precision sintered

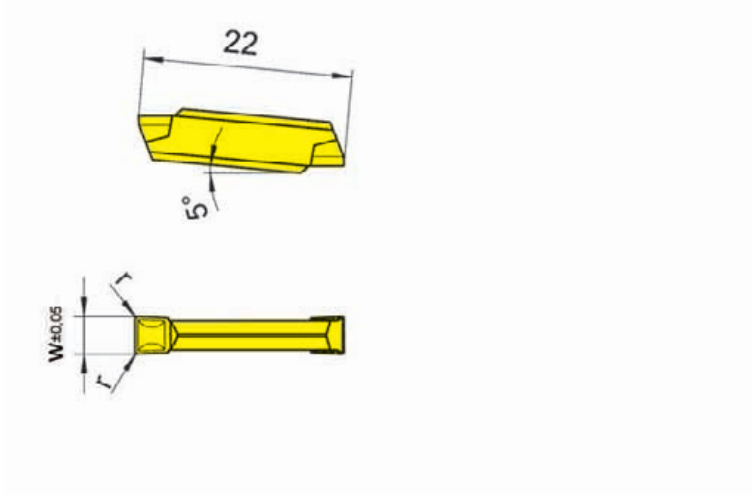

für Klemhalter
for Toolholder

Typ H224
Type B224
BK224

Wechselgenauigkeit
Länge ± 0,06 mm
Indexability length ± 0,06 mm



Bestellnummer Part number	w	r	Größe Size	AL96	AS62	AS66	H54	TC92	TF45	TI22	TI25	TN32	TN35
S224.0300.32	3	0,2	03	▲	▲	▲	▲	▲	▲	▲	▲	▲	▲
S224.0300.34	3	0,4	03	▲	▲	▲	▲	▲	▲	▲	▲	▲	▲
S224.0400.32	4	0,2	04	▲	▲	▲	▲	▲	▲	▲	▲	▲	▲
S224.0400.34	4	0,4	04	▲	▲	▲	▲	▲	▲	▲	▲	▲	▲
S224.0500.34	5	0,4	05	▲	▲	▲	▲	▲	▲	▲	▲	▲	▲
S224.0500.38	5	0,8	05	▲	▲	▲	▲	▲	▲	▲	▲	▲	▲
S224.0600.34	6	0,4	06	▲	▲	▲	▲	▲	▲	▲	▲	▲	▲
S224.0600.38	6	0,8	06	▲	▲	▲	▲	▲	▲	▲	▲	▲	▲
▲ ab Lager / on stock Δ 4 Wochen / 4 weeks x auf Anfrage / upon request				P	•	•	•	•	•	•	•	•	•
● empfohlen / recommended				M	-	-	o	•	-	•	-	-	•
o bedingt einsetzbar / alternative recommendation				K	•	-	•	-	-	•	-	-	•
- nicht geeignet / not suitable				N	•	-	•	-	-	•	-	-	•
unbeschichtete HM-Sorten / uncoated grades				S	-	-	o	-	-	•	-	-	•
beschichtete HM-Sorten / coated grades				H	-	-	-	-	-	-	-	-	-
bestückt/Cermet / brazed/Cermet													

Abmessungen in mm
Dimensions in mm

Wendeschneidplatten sind in rechten und linken Klemhaltern verwendbar.
Indexable inserts can be used in right and left hand toolholders.

HM-Sorten
Carbide grades

Wendeschneidplatte

Indexable insert

S224...5.

präzisionsgesintert
precision sintered



Geometrie .5.

Leichtschneidende Geometrie für Werkstoffe mittlerer Festigkeit.
Easy cutting geometry for materials with medium strength.

Hauptmerkmale Characteristics

- sichere Spankontrolle über einen weiten Vorschubsbereich
- leichtschneidend - geringe Leistungsaufnahme
- saubere Nutflanken durch Spanformung
- Produktionssicherheit durch Spanformung

Einsatzgebiete Applications

- Einstechen: Stechtiefe bis 18 mm
- Längsdrehen: Schnitttiefe a_p bis 3 mm*
- Grooving: Depth of groove up to 18 mm
- Side turning: Depth of cut a_p up to 3 mm*



- excellent swarf on a wide feed range
- easy cutting - low power requirement
- reduced swarf width gives high flank surface finish
- excellent swarf control allows production security

Vorschub f Feed rate f

- Einstechen: bis 0,45 mm/U*
- Längsdrehen: bis 0,6 mm/U*
- Grooving: up to 0,45 mm/rev*
- Side turning: up to 0,6 mm/rev*

* abhängig von der Plattenbreite
* dependent upon width of insert

Formwendeschneidplatten, Zwischenmaße oder andere Eckenradien sind auf Anfrage erhältlich!
Wendeschneidplatten sind in **rechten und linken** Klemmhaltern verwendbar.

Indexable inserts with profiles, intermediate sizes or other edge radii are available upon request.
Indexable inserts can be used in **right and left hand** toolholders.

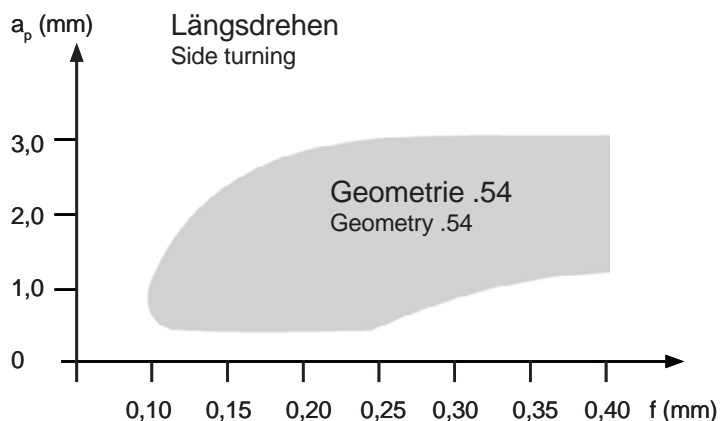

Spanbruchdiagramm S224.0400.54, Werkstoff 16MnCr5
Chip control graph S224.0500.54 material 16MnCr5

Einstechen und Längsdrehen

Grooving and Side Turning



Wendeschneidplatte

Indexable insert

S224

mit Spanformung
with chip forming

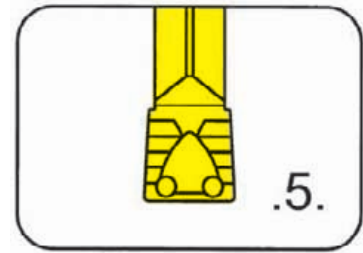

Stechtiefe bis
Stechbreite

Depth of groove up to
Width of groove

18 mm
2-6 mm

präzisionsgesintert
precision sintered

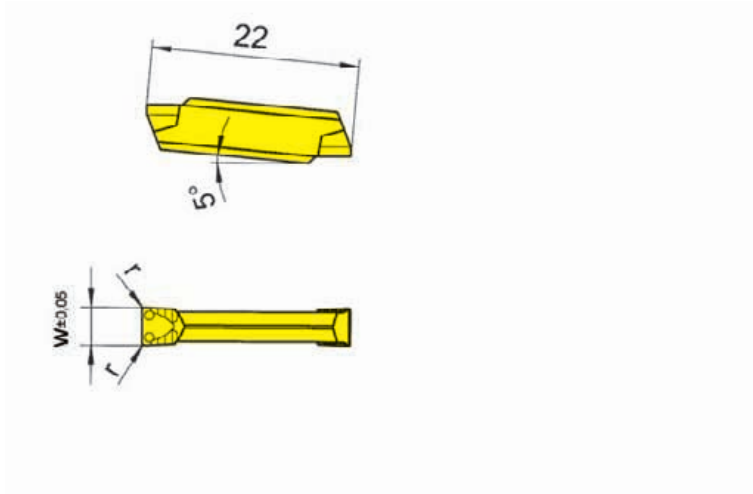

für Klemmhalter
for Toolholder

Typ H224
Type B224
BK224

Wechselgenauigkeit
Länge ± 0,06 mm
Indexability length ± 0,06 mm

Bestellnummer Part number	w	r	Größe Size	AL96	AS62	AS66	EG56	H54	TC92	TF45	TI25	TN32	TN35
S224.0200.52	2,0	0,2	01		▲	▲	▲						
S224.0250.52	2,5	0,2	02		▲	▲	▲						
S224.0300.52	3,0	0,2	03	△	▲	▲	▲	△	▲	▲	▲	▲	▲
S224.0300.54	3,0	0,4	03	▲	▲	▲	▲	△	▲	▲	▲	▲	▲
S224.0400.52	4,0	0,2	04	▲	▲	▲	▲	△	△	▲	▲	▲	▲
S224.0400.54	4,0	0,4	04	▲	▲	▲	▲	△	▲	▲	▲	▲	▲
S224.0500.54	5,0	0,4	05	△	▲	▲	▲	△	▲	▲	▲	▲	▲
S224.0500.58	5,0	0,8	05	▲	▲	▲	△	△	▲	△	▲	△	△
S224.0600.54	6,0	0,4	06	△	▲	▲	▲	△	▲	▲	▲	△	▲
S224.0600.58	6,0	0,8	06	△	▲	▲	△	△	△	△	△	△	△
▲ ab Lager / on stock △ 4 Wochen / 4 weeks x auf Anfrage / upon request				P	•	•	•	•	•	•	•	•	•
● empfohlen / recommended				M	-	-	o	o	•	-	•	•	-
o bedingt einsetzbar / alternative recommendation				K	•	-	•	o	-	-	•	•	-
- nicht geeignet / not suitable				N	•	-	•	-	-	-	•	•	-
unbeschichtete HM-Sorten / uncoated grades				S	-	-	o	-	-	-	•	•	-
beschichtete HM-Sorten / coated grades				H	-	-	-	-	-	-	-	-	-
bestückt/Cermet / brazed/Cermet													

Abmessungen in mm
Dimensions in mm

HM-Sorten
Carbide grades

Wendeschneidplatten sind in rechten und linken Klemmhaltern verwendbar.
Indexable inserts can be used in right and left hand toolholders.



Wendeschneidplatte

Indexable insert

S224...A.

präzisionsgesintert
precision sintered



Geometrie .A.

Geometry

Geometrie mit sicherem Spanbruch für Werkstoffe mittlerer Festigkeit
Geometry with excellent chip breaking for materials with medium strength

Hauptmerkmale Characteristics

- sichere Spankontrolle über einen weiten Vorschubsbereich
- kontrollierte Späne, nicht nur im Vollschnitt
- saubere Nutflanken durch Spanformung
- Produktionssicherheit durch kontrollierten Spanablauf

Einsatzgebiete Applications

- Einstechen: Stechtiefe bis 18 mm
- Längsdrehen: Schnitttiefe a_p bis 2,5 mm*
- Grooving: Depth of groove up to 18 mm
- Side turning: Depth of cut a_p up to 2,5 mm*



- excellent swarf on a wide feed range
- excellent swarf control, also by partial cutting
- reduced swarf width gives high flank surface finish
- excellent swarf control allows production security

Vorschub f Feed rate f

- Einstechen: bis 0,3 mm/U*
- Längsdrehen: bis 0,3 mm/U*
- Grooving: up to 0,3 mm/rev*
- Side turning: up to 0,3 mm/rev*

* abhängig von der Plattenbreite
* dependent upon width of insert

Formwendeschneidplatten, Zwischenmaße oder andere Eckenradien sind auf Anfrage erhältlich!
Wendeschneidplatten sind in **rechten und linken** Klemmhaltern verwendbar.

Indexable inserts with profiles, intermediate sizes or other edge radii are available upon request.
Indexable inserts can be used in **right and left hand** toolholders.

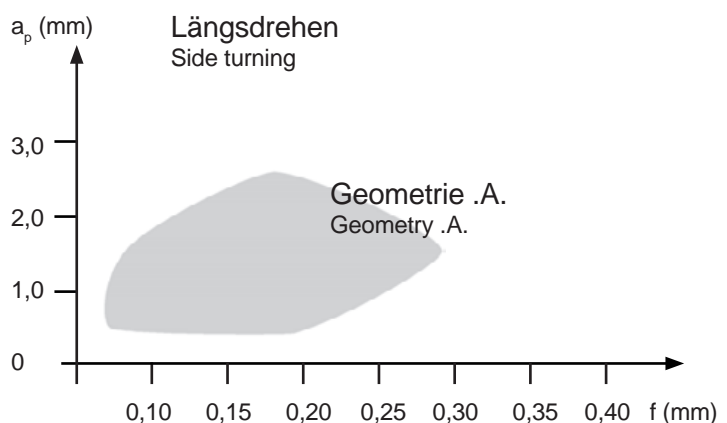

Spanbruchdiagramm S224.0400.A4, Werkstoff 16MnCr5
Chip control graph S224.0500.A4 material 16MnCr5

Einstechen und Längsdrehen

Grooving and Side Turning



Wendeschneidplatte

Indexable insert

S224

mit Spanformung
with chip forming

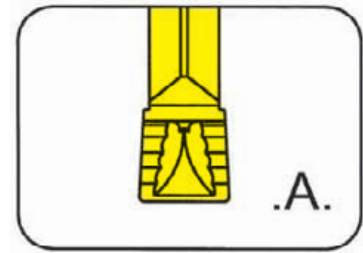

Stechtiefe bis
Stechbreite

Depth of groove up to
Width of groove

18 mm
3-6 mm

präzisionsgesintert
precision sintered

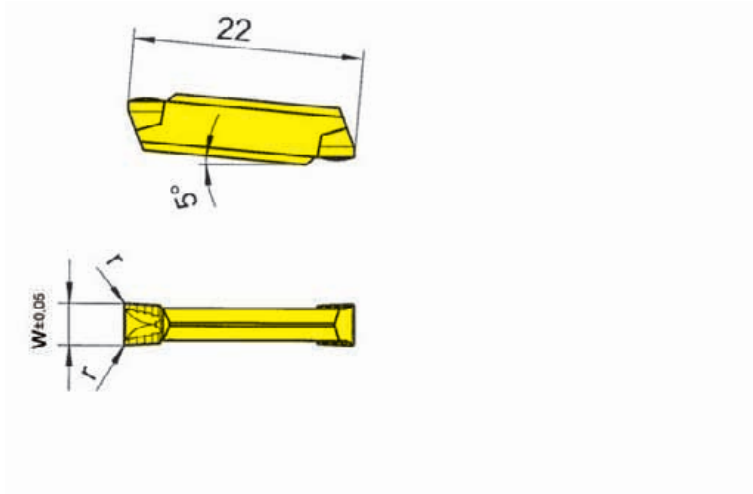

für Klemhalter
for Toolholder

Typ H224
Type B224
BK224

Wechselgenauigkeit
Länge ± 0,06 mm
Indexability length ± 0,06 mm

Bestellnummer Part number	w	r	Größe Size	AL96	AS62	AS65	TC92	TF45	TI22	TI25	TN32	TN35
S224.0300.A2	3	0,2	03	▲	▲		△	▲	▲	▲	▲	▲
S224.0300.A4	3	0,4	03	△	▲		▲	▲	△	▲	▲	▲
S224.0400.A2	4	0,2	04	△	▲		△	▲	△	▲	△	▲
S224.0400.A4	4	0,4	04	△	▲	▲	△	▲	△	▲	▲	▲
S224.0500.A4	5	0,4	05	△	▲		△	▲	△	▲	▲	▲
S224.0500.A8	5	0,8	05	△	▲		△	△		△	▲	△
S224.0600.A4	6	0,4	06	△	△		△	△		▲	▲	▲
S224.0600.A8	6	0,8	06	△	▲		△	△		△	△	▲
				P	●	●	●	●	●	●	●	●
				M	-	-	o	-	●	-	-	●
				K	●	-	o	-	●	-	-	●
				N	●	-	-	-	●	-	-	●
				S	-	-	-	-	●	-	-	●
				H	-	-	-	-	-	-	-	-

▲ ab Lager / on stock △ 4 Wochen / 4 weeks x auf Anfrage / upon request
 ● empfohlen / recommended
 o bedingt einsetzbar / alternative recommendation
 - nicht geeignet / not suitable
 ■ unbeschichtete HM-Sorten / uncoated grades
 ■ beschichtete HM-Sorten / coated grades
 ■ bestückt/Cermet / brazed/Cermet

Abmessungen in mm
Dimensions in mm

Wendeschneidplatten sind in rechten und linken Klemmaltern verwendbar.
Indexable inserts can be used in right and left hand toolholders.

HM-Sorten
Carbide grades



Wendeschnidplatte

Indexable insert

S224...D.

präzisionsgesintert
precision sintered

Geometrie .D.

Leichtschneidende Geometrie mit Spanformung.
Easy cutting geometry with chip former.

Hauptmerkmale Characteristics

- besonders geeignet für die Innenbearbeitung
- leichtschneidend
- saubere Nutflanken durch Spanformung
- Spanformung auch bei geringen Vorschüben

- mainly used for internal grooving
- very positive geometry
- reduced swarf width gives high flank surface finish
- reduced swarf even at low feedrate

Einsatzgebiete Applications

- Einstechen:
Stechtiefe bis 18 mm
- Längsdrehen:
Schnitttiefe a_p bis 3 mm*
- Grooving:
Depth of groove up to 18 mm
- Side turning:
Depth of cut a_p up to 3 mm*

Vorschub f Feed rate f

- Einstechen: bis 0,15 mm/U*
- Längsdrehen: bis 0,2 mm/U*
- Grooving: up to 0,15 mm/rev*
- Side turning: up to 0,2 mm/rev*



Formwendeschnidplatten, Zwischenmaße oder andere Eckenradien sind auf Anfrage erhältlich!
Wendeschnidplatten sind in **rechten und linken** Klemmhaltern verwendbar.

Indexable inserts with profiles, intermediate sizes or other edge radii are available upon request.
Indexable inserts can be used in **right and left hand** toolholders.

* abhängig von der Plattenbreite
* dependent upon width of insert

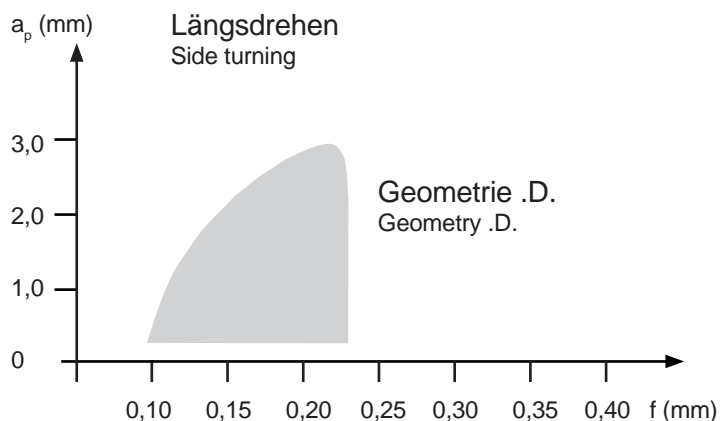

Spanbruchdiagramm S224.0300.D2, Werkstoff 16MnCr5
Chip control graph S224.0300.D2 material 16MnCr5

Einstechen und Längsdrehen

Grooving and Side Turning



Wendeschneidplatte

Indexable insert

S224

mit Spanformung
with chip forming

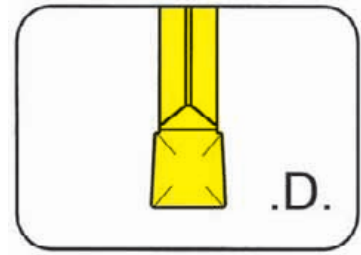

Stechtiefe bis
Stechbreite

Depth of groove up to
Width of groove

18 mm
2-4 mm

D2 präzisionsgesintert / *D2.G präzisionsgeschliffen
D2 precision sintered / *D2.G precision ground

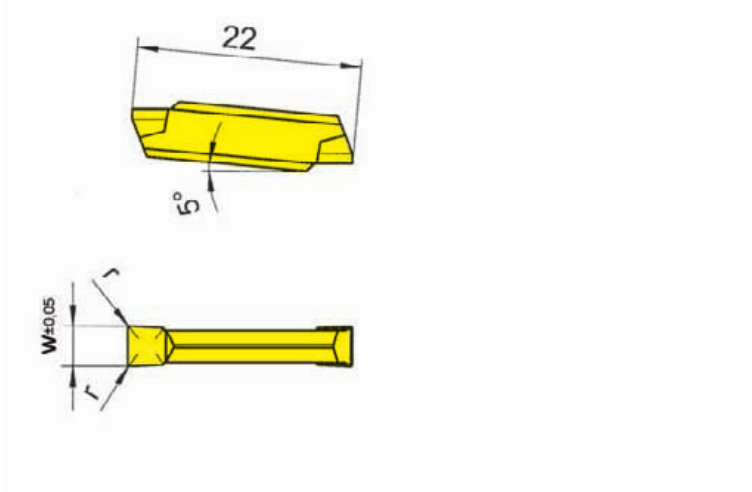

für Klemmhalter
for Toolholder

Typ H224
Type B224
BK224

*Wechselgenauigkeit
Länge $\pm 0,06$ mm
Indexability length $\pm 0,06$ mm

Bestellnummer Part number	w	r	Größe Size	H54	TF45	TF46	T122	T125	TN32	TN35
S224.0200.D2G	2,0	0,2	01		x					
S224.0200.D2	2,0	0,2	01	▲	▲	▲		▲	▲	▲
S224.0250.D2.G	2,5	0,2	02			▲	▲			
S224.0250.D2	2,5	0,2	02	△	▲	▲		▲	▲	▲
S224.0300.D2.G	3,0	0,2	03		▲	▲	▲			
S224.0300.D2	3,0	0,2	03	▲	▲	▲		▲	▲	▲
S224.0400.D2.G	4,0	0,2	04			▲	▲			
S224.0400.D2	4,0	0,2	04	△	▲	▲		▲	▲	▲
▲ ab Lager / on stock				P	●	●	●	●	●	●
● empfohlen / recommended				M	●	●	○	-	-	●
○ bedingt einsetzbar / alternative recommendation				K	-	●	●	-	-	●
- nicht geeignet / not suitable				N	-	●	●	-	-	●
unbeschichtete HM-Sorten / uncoated grades				S	-	●	○	-	-	●
beschichtete HM-Sorten / coated grades				H	-	-	-	-	-	-
bestückt/Cermet / brazed/Cermet										

Abmessungen in mm
Dimensions in mm

Wendeschneidplatten sind in rechten und linken Klemmhaltern verwendbar.
Indexable inserts can be used in right and left hand toolholders.

HM-Sorten
Carbide grades



Wendeschneidplatte

Indexable insert

S224...C.

präzisionsgesintert
precision sintered



Geometrie .C. Geometry

Geometrie zum Abstechen.
Geometry for parting off.

Hauptmerkmale Characteristics

- sichere Spankontrolle über empfohlenen Vorschubsbereich
- saubere Nutflanken durch Spanformung
- Produktionssicherheit durch kontrollierten Spanablauf
- excellent swarf control on the recommended feed range
- reduced swarf width gives high flank surface finish
- excellent swarf control allows production security

Einsatzgebiete Applications

- Einstechen und Abstechen:
Stechtiefe bis 18 mm
- Grooving and parting off:
Depth of groove up to 18 mm

Vorschub f Feed rate f

- Abstechen: 0,02 bis 0,1 mm/U
- Parting off: 0,02 up to 0,1 mm/rev

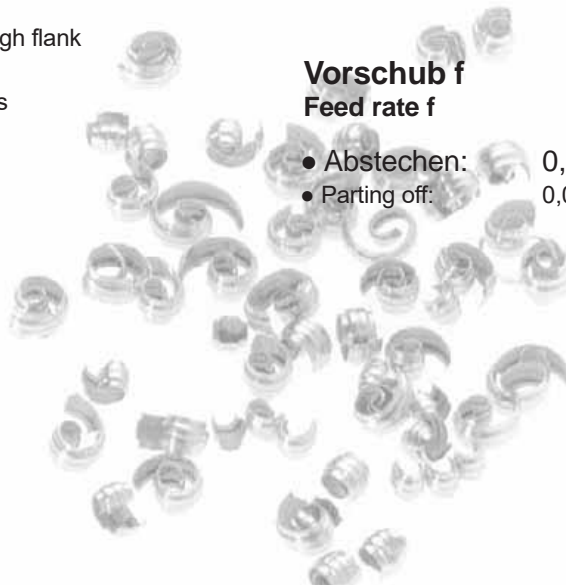

Bitte beachten:

Der empfohlene Vorschub ist bei Schneidplatten mit Abstechschräge um 20-50% zu verringern. Beste Standmengen und Oberflächen werden mit geraden Schneiden erreicht. Beim Abstechen von Vollmaterial ist der Vorschub vor dem Abstich deutlich zu reduzieren.

Please note:

The recommended feedrate has to be reduced by 20-50% with right or left hand inserts. Best tool life and surfaces will be obtained with neutral inserts. Reduce the feed rate before parting off when machining solid bars.

Einstechen und Abstechen

Grooving and Parting Off



Wendeschneidplatte

Indexable insert

S224

mit Spanformung
with chip forming

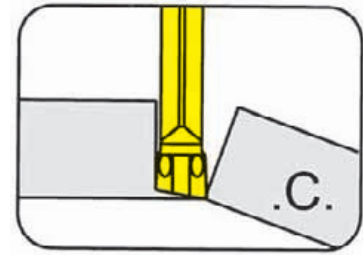

Stechtiefe bis Stechbreite	Depth of groove up to Width of groove	18 mm 2-3 mm
-------------------------------	--	-----------------

präzisionsgesintert
precision sintered

für Klemmhalter
for Toolholder

Typ H224
Type B224
BK224

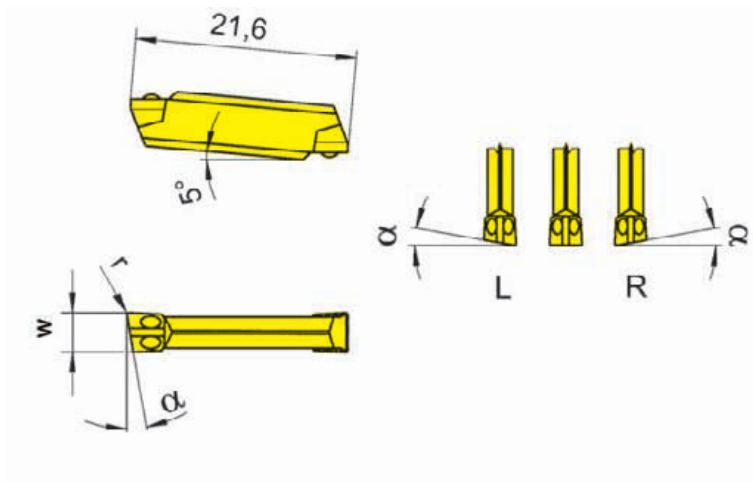

R = rechts wie gezeichnet
R = right hand version shown

L = links spiegelbildlich
L = left hand version

Wechselgenauigkeit
Länge ± 0,06 mm
Indexability length ± 0,06 mm



Bestellnummer Part number	w	r	α	Größe Size	TC92	TF45	TI25	TN35
S224.0020.C1	2,0	0,15	0°	01	▲	▲	▲	▲
R/LS224.0520.C1	2,0	0,15	5°	01	▲/▲	▲/▲		▲/▲
R/LS224.0820.C1	2,0	0,15	8°	01	▲/▲	▲/▲		▲/▲
R/LS224.1520.C1	2,0	0,15	15°	01	▲/▲	▲/▲		▲/▲
S224.0025.C1	2,5	0,15	0°	02	▲	▲	▲	▲
R/LS224.0525.C1	2,5	0,15	5°	02	▲/▲	▲/▲		▲/▲
R/LS224.0825.C1	2,5	0,15	8°	02	▲/▲	▲/▲		▲/▲
S224.0030.C1	3,0	0,15	0°	03	▲	▲	▲	▲
R/LS224.0530.C1	3,0	0,15	5°	03	▲/▲	▲/▲		▲/▲
R/LS224.0830.C1	3,0	0,15	8°	03	▲/▲	▲/▲		▲/▲

▲ ab Lager / on stock Δ 4 Wochen / 4 weeks x auf Anfrage / upon request

● empfohlen / recommended

o bedingt einsetzbar / alternative recommendation

- nicht geeignet / not suitable

unbeschichtete HM-Sorten / uncoated grades

beschichtete HM-Sorten / coated grades

bestückt/Cermet / brazed/Cermet

Abmessungen in mm

Dimensions in mm

Ausführung R oder L angeben

State R or L version

Weitere Abmessungen auf Anfrage

Further sizes upon request

Wendeschneidplatten sind in rechten und linken Klemmhaltern verwendbar.

Indexable inserts can be used in right and left hand toolholders.

P	●	●	●	●
M	-	●	●	●
K	-	●	●	●
N	-	●	●	●
S	-	●	●	●
H	-	-	-	-

HM-Sorten
Carbide grades

Einstechen und Längsdrehen

Grooving and Side Turning



Wendeschneidplatte

Indexable insert

S224

mit Spanformung
with chip forming

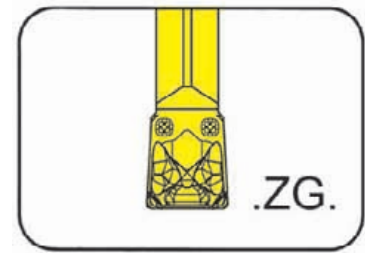

Stechtiefe bis Stechbreite	Depth of groove up to Width of groove	18 mm 3 mm
-------------------------------	--	---------------

ZG präzisionsgeschliffen
ZG precision ground

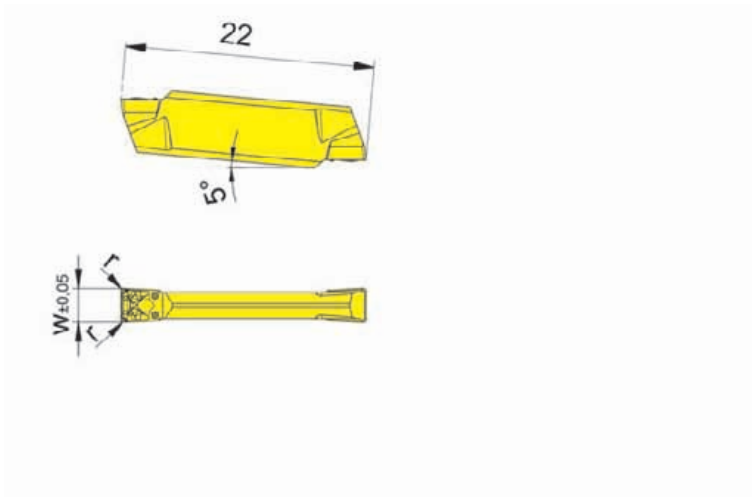

für Klemmhalter
for Toolholder

Typ H224
Type B224
BK224

Wechselgenauigkeit
Länge ± 0,06 mm
Indexability length ± 0,06 mm

G

Bestellnummer Part number	w	r	Größe Size	ALXT
S224.0300.ZG2	3	0,2	03	▲
				P ●
				M ○
				K -
				N -
				S -
				H -

- ▲ ab Lager / on stock Δ 4 Wochen / 4 weeks x auf Anfrage / upon request
- empfohlen / recommended
- bedingt einsetzbar / alternative recommendation
- nicht geeignet / not suitable
- unbeschichtete HM-Sorten / uncoated grades
- beschichtete HM-Sorten / coated grades
- bestückt/Cermet / brazed/Cermet

Abmessungen in mm
Dimensions in mm

Wendeschneidplatten sind in rechten und linken Klemmhaltern verwendbar.
Indexable inserts can be used in right and left hand toolholders.

HM-Sorten
Carbide grades

Einstechen und Längsdrehen

Grooving and Side Turning



Wendeschneidplatte

Indexable insert

S224

mit Spanformrille
with chip former

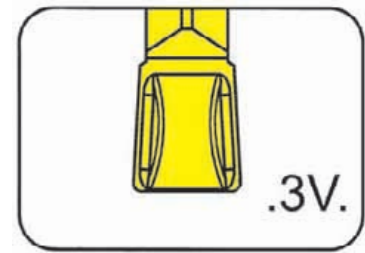

Stechtiefe bis Stechbreite	Depth of groove up to Width of groove	18 mm 3-4 mm
-------------------------------	--	-----------------

präzisionsgesintert
precision sintered

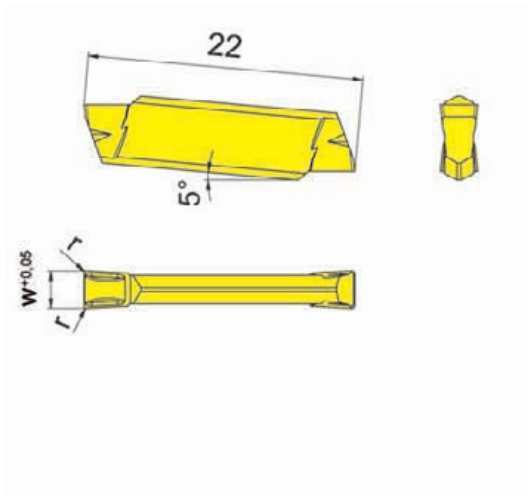

für Klemmhalter
for Toolholder

Typ H224
Type B224
BK224

Wechselgenauigkeit
Länge $\pm 0,06$ mm
Indexability length $\pm 0,06$ mm

Bestellnummer Part number	w	r	Größe Size	AS45	HP65
S224.0300.3V2	3	0,2	03	▲	▲
S224.0400.3V3	4	0,3	04	▲	▲
				P ●	●
				M ●	●
				K ●	●
				N ●	●
				S ○	○
				H -	-

- ▲ ab Lager / on stock Δ 4 Wochen / 4 weeks x auf Anfrage / upon request
- empfohlen / recommended
- bedingt einsetzbar / alternative recommendation
- nicht geeignet / not suitable
- unbeschichtete HM-Sorten / uncoated grades
- beschichtete HM-Sorten / coated grades
- bestückt/Cermet / brazed/Cermet

Abmessungen in mm
Dimensions in mm

Wendeschneidplatten sind in rechten und linken Klemmhaltern verwendbar.
Indexable inserts can be used in right and left hand toolholders.

HM-Sorten
Carbide grades



Einstechen und Abstechen

Grooving and Parting Off



Wendeschneidplatte

Indexable insert

S224

mit Spanformrille
with chip former

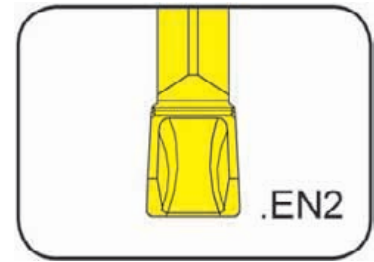

Stechtiefe bis Stechbreite	Depth of groove up to Width of groove	18 mm 2-3 mm
-------------------------------	--	-----------------

präzisionsgesintert
precision sintered

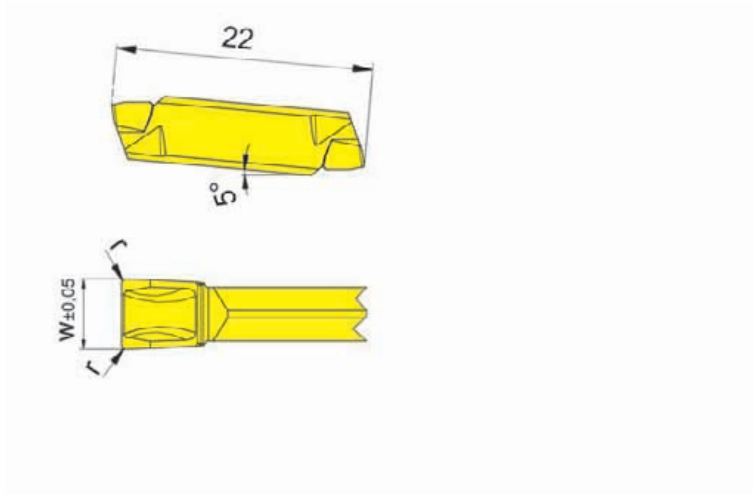

für Klemhalter
for Toolholder

Typ H224
Type B224
BK224

Wechselgenauigkeit
Länge ± 0,06 mm
Indexability length ± 0,06 mm

G

Bestellnummer Part number	w	r	Größe Size	AS62	AS65
S224.0200.EN2	2,0	0,2	01	▲	▲
S224.0250.EN2	2,5	0,2	02	▲	▲
S224.0300.EN2	3,0	0,2	03	▲	▲
				P ●	●
				M -	○
				K -	○
				N -	-
				S -	-
				H -	-

▲ ab Lager / on stock Δ 4 Wochen / 4 weeks x auf Anfrage / upon request

● empfohlen / recommended

○ bedingt einsetzbar / alternative recommendation

- nicht geeignet / not suitable

□ unbeschichtete HM-Sorten / uncoated grades

■ beschichtete HM-Sorten / coated grades

■ bestückt/Cermet / brazed/Cermet

Abmessungen in mm

Dimensions in mm

Weitere Abmessungen auf Anfrage

Further sizes upon request

Wendeschneidplatten sind in rechten und linken Klemmaltern verwendbar.

Indexable inserts can be used in right and left hand toolholders.

HM-Sorten
Carbide grades

Einstechen und Längsdrehen

Grooving and Side Turning



Wendeschneidplatte

Indexable insert

S224

mit Spantreppe
with chip breaker

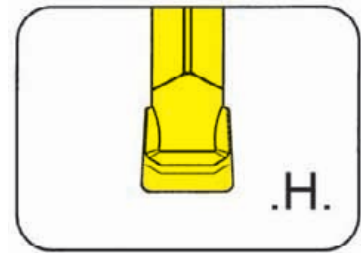

Stechtiefe bis Stechbreite	Depth of groove up to Width of groove	18 mm 3-6 mm
-------------------------------	--	-----------------

präzisionsgesintert
precision sintered

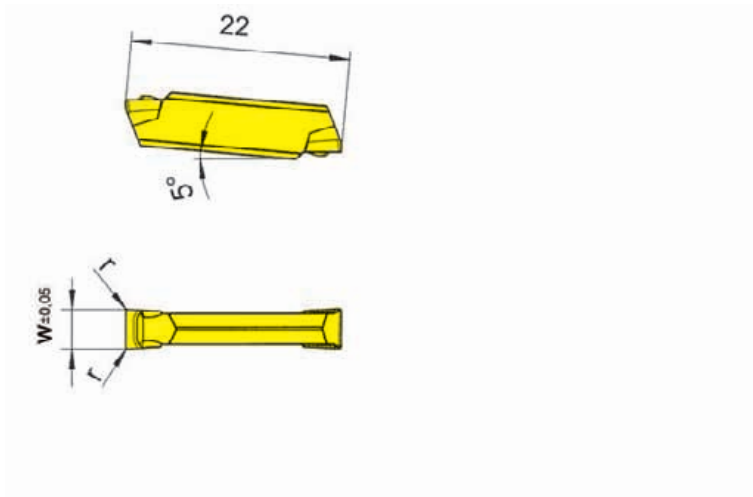

für Klemhalter
for Toolholder

Typ H224
Type B224
BK224

Wechselgenauigkeit
Länge $\pm 0,06$ mm
Indexability length $\pm 0,06$ mm



Bestellnummer Part number	w	r	Größe Size	AL96	TF42
S224.0300.H4	3	0,4	03	Δ	▲
S224.0400.H4	4	0,4	04	Δ	▲
S224.0500.H6	5	0,6	05	▲	▲
S224.0500.H8	5	0,8	05	▲	Δ
S224.0600.H6	6	0,6	06	Δ	Δ
S224.0600.H8	6	0,8	06	▲	Δ
				P	•
				M	-
				K	•
				N	•
				S	-
				H	-

- ▲ ab Lager / on stock Δ 4 Wochen / 4 weeks x auf Anfrage / upon request
- empfohlen / recommended
- o bedingt einsetzbar / alternative recommendation
- nicht geeignet / not suitable
- unbeschichtete HM-Sorten / uncoated grades
- beschichtete HM-Sorten / coated grades
- bestückt/Cermet / brazed/Cermet

Abmessungen in mm
Dimensions in mm

Wendeschneidplatten sind in rechten und linken Klemmhaltern verwendbar.
Indexable inserts can be used in right and left hand toolholders.

HM-Sorten
Carbide grades

Axialeinstechen

Face Grooving



Wendeschneidplatte

Indexable insert

S224

mit Spanformung
with chip forming

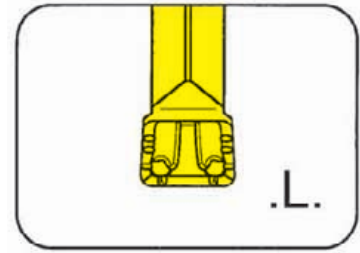

Stechtiefe bis Stechbreite	Depth of groove up to Width of groove	18 mm 3-6 mm
-------------------------------	--	-----------------

präzisionsgesintert
precision sintered

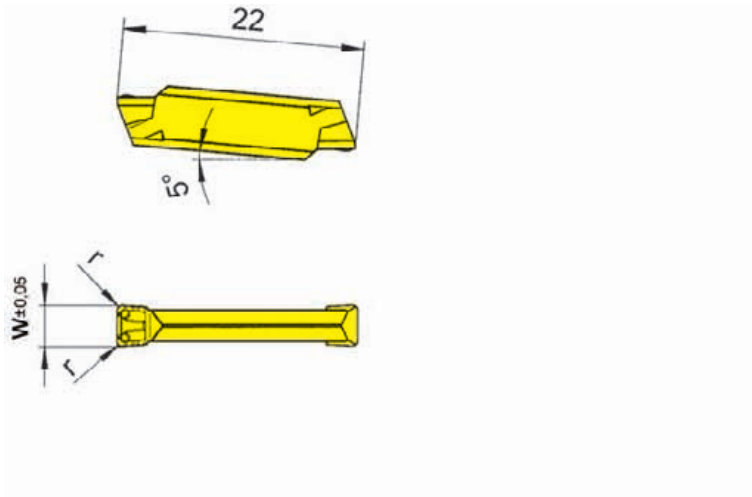

für Klemhalter
for Toolholder

Typ H224
Type B224
BK224

Wechselgenauigkeit
Länge ± 0,06 mm
Indexability length ± 0,06 mm

G

Bestellnummer Part number	w	r	Größe Size	AL96	AS62	AS65	AS66	ASG6	TF42	TI22	
S224.0300.L4	3	0,4	03	▲	▲	▲	▲	△			
S224.0400.L4	4	0,4	04	▲	▲		▲		▲	▲	
S224.0500.L4	5	0,4	05	▲	▲		△	△	▲	▲	
S224.0500.L6	5	0,6	05	△	▲		▲	△	▲	△	
S224.0600.L4	6	0,4	06	▲	▲				▲	▲	
S224.0600.L6	6	0,6	06	▲	▲			△	△	▲	
▲ ab Lager / on stock △ 4 Wochen / 4 weeks x auf Anfrage / upon request				P	●	●	●	●	●	●	●
● empfohlen / recommended				M	-	-	○	○	-	-	
○ bedingt einsetzbar / alternative recommendation				K	●	-	●	●	○	-	
- nicht geeignet / not suitable				N	●	-	●	●	-	-	
■ unbeschichtete HM-Sorten / uncoated grades				S	-	-	○	○	-	-	
■ beschichtete HM-Sorten / coated grades				H	-	-	-	-	-	-	
■ bestückt/Cermet / brazed/Cermet											

Abmessungen in mm
Dimensions in mm

Wendeschneidplatten sind in rechten und linken Klemmhaltern verwendbar.
Indexable inserts can be used in right and left hand toolholders.

HM-Sorten
Carbide grades

Einstechen und Längsdrehen

Grooving and Side Turning



Schneidplatte

Insert

S124

mit Spanformung
with chip forming

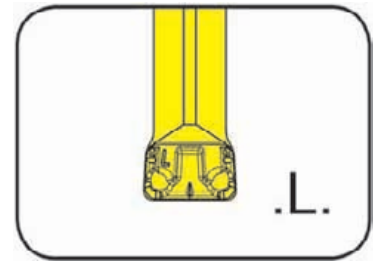

Stechtiefe bis
Stechbreite

Depth of groove up to
Width of groove

18 mm
6 mm

präzisionsgesintert
precision sintered

für Klemmhalter
for Toolholder

Typ H224
Type B224
BK224

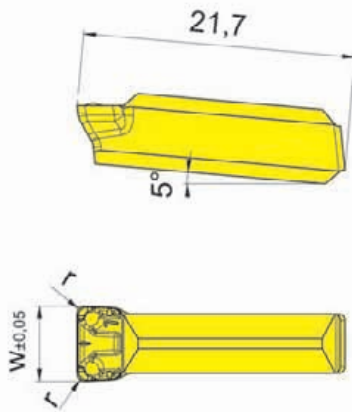

Bestellnummer Part number	w	r	Größe Size	AS42	AS46
S124.0600.L6	6	0,6	06	▲	▲
				P	•
				M	•
				K	•
				N	•
				S	•
				H	-

- ▲ ab Lager / on stock Δ 4 Wochen / 4 weeks x auf Anfrage / upon request
- empfohlen / recommended
- o bedingt einsetzbar / alternative recommendation
- nicht geeignet / not suitable
- unbeschichtete HM-Sorten / uncoated grades
- beschichtete HM-Sorten / coated grades
- bestückt/Cermet / brazed/Cermet

Abmessungen in mm
Dimensions in mm

Schneidplatten sind in **rechten und linken** Klemmhaltern verwendbar.
Indexable inserts can be used in **right and left** hand toolholders.

HM-Sorten
Carbide grades



Einstechen und Abstechen

Grooving and Parting Off



Wendeschneidplatte

Indexable insert

S224

mit Spanformung
with chip forming

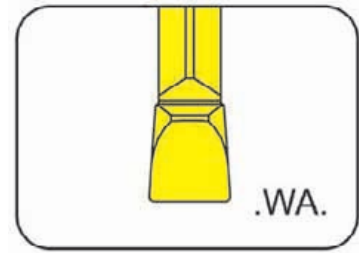

Stechbreite Stechtiefe bis	Width of groove Depth of groove up to	2-3 mm 18 mm
-------------------------------	--	-----------------

präzisionsgeschliffen und poliert
precision ground and polished

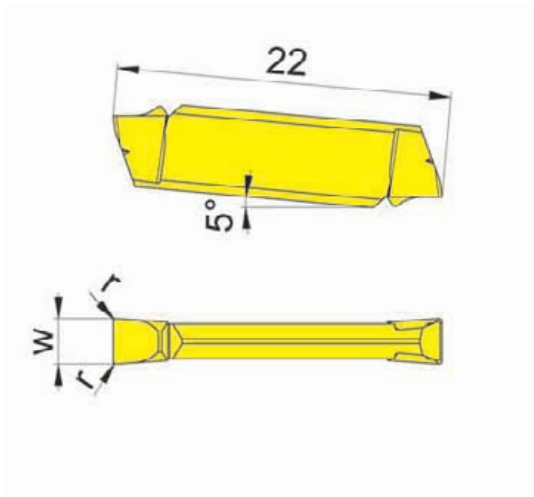

für Klemmhalter
for Toolholder

Typ H224
Type B224
BK224

G

Bestellnummer Part number	w	r	Größe Size	K10	DD26
S224.0200.WA2	2	0,2	01	▲	▲
S224.0300.WA2	3	0,2	03	▲	▲
				P ●	
				M ○	
				K ●	
				N ●	
				S ○	
				H -	

- ▲ ab Lager / on stock Δ 4 Wochen / 4 weeks x auf Anfrage / upon request
- empfohlen / recommended
- bedingt einsetzbar / alternative recommendation
- nicht geeignet / not suitable
- unbeschichtete HM-Sorten / uncoated grades
- beschichtete HM-Sorten / coated grades
- bestückt/Cermet / brazed/Cermet

Abmessungen in mm
Dimensions in mm

Wendeschneidplatten sind in rechten und linken Klemmhaltern verwendbar.
Indexable inserts can be used in right and left hand toolholders.

HM-Sorten
Carbide grades

Einstechen und Längsdrehen

Grooving and Side Turning



Wendeschneidplatte

Indexable insert

S224

mit Spanformung
with chip forming

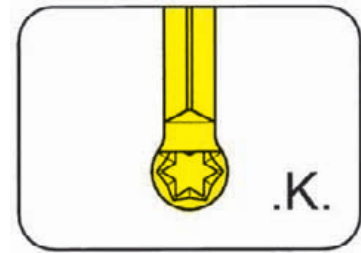

Stechtiefe bis	Depth of groove up to	18 mm
Stechbreite	Width of groove	2-6 mm
Vollradius	Full radius	1-3 mm

präzisionsgesintert
precision sintered

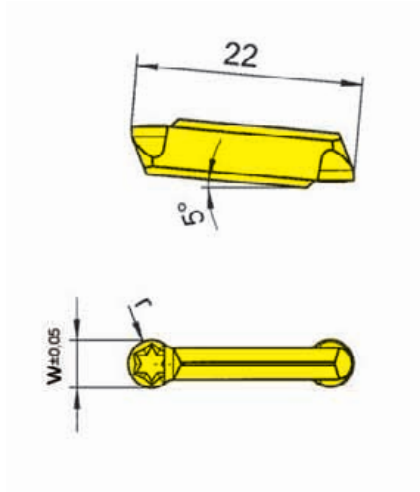

für Klemhalter
for Toolholder

Typ H224
Type B224
BK224

Wechselgenauigkeit
Länge ± 0,06 mm
Indexability length ± 0,06 mm

Bestellnummer Part number	w	r	Größe Size	AL96	AS62	AS66	P20	TC92	TF42	TN32	TN35
S224.0010.K2	2	1,0	01		▲	▲			▲		
S224.0015.K3	3	1,5	03	▲	▲	▲	△	▲	▲	▲	
S224.0020.K4	4	2,0	04	▲	▲	▲	△	▲	▲	▲	
S224.0025.K5	5	2,5	05	▲	▲	▲	△	▲	▲	▲	△
S224.0030.K6	6	3,0	06		▲	▲	△				
				P	●	●	●	●	●	●	●
				M	-	-	○	-	-	-	●
				K	●	-	●	-	-	-	●
				N	●	-	●	-	-	-	●
				S	-	-	○	-	-	-	●
				H	-	-	-	-	-	-	-

▲ ab Lager / on stock △ 4 Wochen / 4 weeks x auf Anfrage / upon request

● empfohlen / recommended

○ bedingt einsetzbar / alternative recommendation

- nicht geeignet / not suitable

■ unbeschichtete HM-Sorten / uncoated grades

■ beschichtete HM-Sorten / coated grades

■ bestückt/Cermet / brazed/Cermet

Abmessungen in mm

Dimensions in mm

Wendeschneidplatten sind in rechten und linken Klemmhaltern verwendbar.

Indexable inserts can be used in right and left hand toolholders.

HM-Sorten
Carbide grades

D_{min} für Eckenfreistriche in Verbindung mit Klemmhalter unter 45°

D_{min} for corner reliefs with toolholder 45°

t _{max}	S224.0010.K2	S224.0015.K3	S224.0020.K4	S224.0025.K5	S224.0030.K6
0,5	Ø 34	Ø 26	Ø 22	Ø 21	Ø 14
1,0	Ø 54	Ø 36	Ø 26	Ø 22	Ø 18
1,5	Ø 54	Ø 36	Ø 26	Ø 22	Ø 18
2,0	Ø 55	Ø 36	Ø 26	Ø 22	Ø 18
2,5	Ø 56	Ø 36	Ø 26	Ø 22	Ø 18
3,0	-	-	-	Ø 22	Ø 18

Einstechen und Längsdrehen

Grooving and Side Turning



Wendeschneidplatte

Indexable insert

S224

mit Spanformung
with chip forming

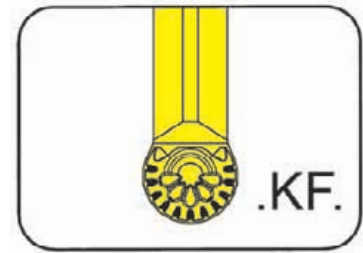

Stechtiefe bis Stechbreite Vollradius	Depth of groove up to Width of groove Full radius	18 mm 3-6 mm 1,5-3 mm
---	---	-----------------------------

präzisionsgesintert
precision sintered

für Klemmhalter
for Toolholder

Typ H224
Type B224
BK224

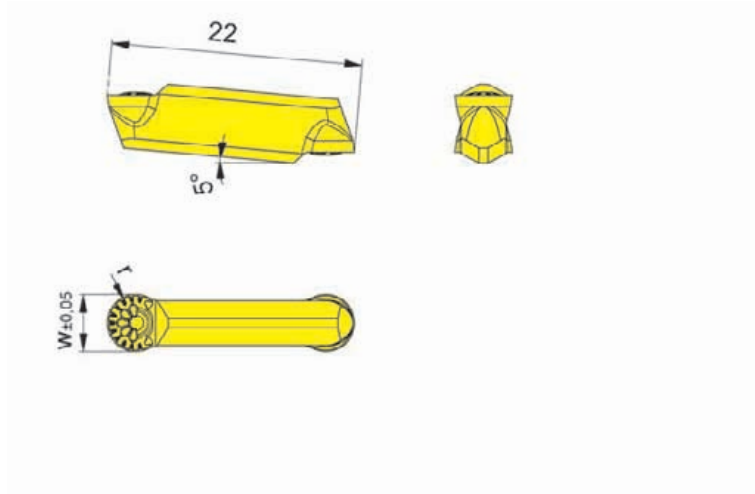

Wechselgenauigkeit
Länge ± 0,06 mm
Indexability length ± 0,06 mm

G

Bestellnummer Part number	w	r	Größe Size	HM-Sorten / Carbide grades		
				AS62	AS66	TA42
S224.0015.KF3	3	1,5	03		▲	x
S224.0020.KF4	4	2,0	04		▲	Δ
S224.0025.KF5	5	2,5	05	Δ	▲	x
S224.0030.KF6	6	3,0	06	x	▲	
				P	●	●
				M	-	○
				K	-	●
				N	-	●
				S	-	○
				H	-	-

- ▲ ab Lager / on stock Δ 4 Wochen / 4 weeks x auf Anfrage / upon request
- empfohlen / recommended
- bedingt einsetzbar / alternative recommendation
- nicht geeignet / not suitable
- unbeschichtete HM-Sorten / uncoated grades
- beschichtete HM-Sorten / coated grades
- bestückt/Cermet / brazed/Cermet

Abmessungen in mm
Dimensions in mm

Wendeschneidplatten sind in rechten und linken Klemmhaltern verwendbar.
Indexable inserts can be used in right and left hand toolholders.

HM-Sorten
Carbide grades

D_{min} für Eckenfreistriche in Verbindung mit Klemmhalter unter 45°
D_{min} for corner reliefs with toolholder 45°

t _{max}	S224.0010.K2	S224.0015.K3	S224.0020.K4	S224.0025.K5	S224.0030.K6
0,5	Ø 26	Ø 22	Ø 21	Ø 14	Ø 14
1,0	Ø 36	Ø 26	Ø 22	Ø 18	Ø 18
1,5	Ø 36	Ø 26	Ø 22	Ø 18	Ø 18
2,0	Ø 36	Ø 26	Ø 22	Ø 18	Ø 18
2,5	Ø 36	Ø 26	Ø 22	Ø 18	Ø 18
3,0	-	-	Ø 22	Ø 18	Ø 18

Einstechen und Längsdrehen

Grooving and Side Turning



Wendeschneidplatte

Indexable insert

S224

mit Spanformung
with chip forming

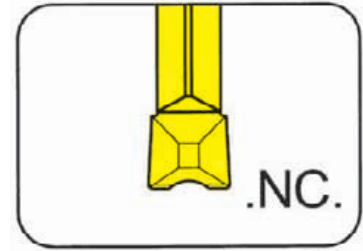

Stechtiefe bis Stechbreite	Depth of groove up to Width of groove	18 mm 2,5-3 mm
-------------------------------	--	-------------------

präzisionsgeschliffen
precision ground

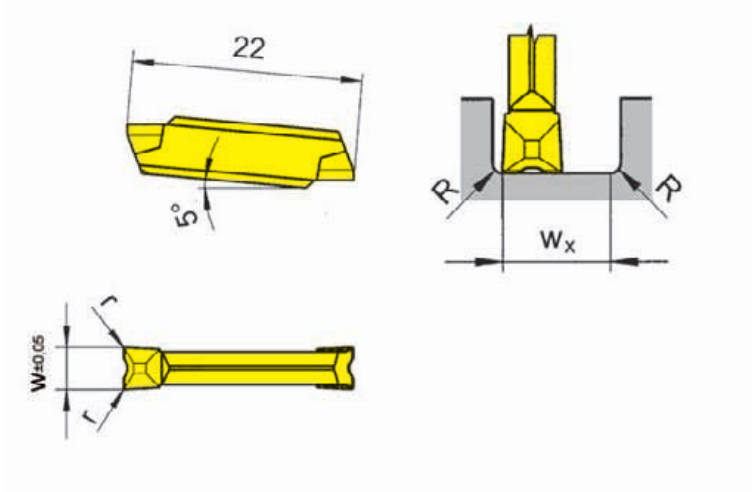

für Klemhalter
for Toolholder

Typ H224
Type B224
BK224

Wechselgenauigkeit
Länge ± 0,025 mm
Indexability length ± 0,025 mm

Bestellnummer Part number	w	r	w _x	Größe Size	TF46	TI22	TI25	TI26
S224.NC25.D2	2,5	0,2	3,6	02	Δ	▲	▲	▲
S224.NC30.D2	3,0	0,2	4,5	03	Δ	▲	▲	▲
					P	•	•	•
					M	o	-	o
					K	•	-	•
					N	•	-	•
					S	o	-	o
					H	-	-	-

- ▲ ab Lager / on stock Δ 4 Wochen / 4 weeks x auf Anfrage / upon request
- empfohlen / recommended
- o bedingt einsetzbar / alternative recommendation
- nicht geeignet / not suitable
- unbeschichtete HM-Sorten / uncoated grades
- beschichtete HM-Sorten / coated grades
- bestückt/Cermet / brazed/Cermet

Abmessungen in mm
Dimensions in mm

$$w_x = \text{Nutbreite} - R_{(\text{rechts})} - R_{(\text{links})}$$

$$w_x = \text{width of groove} - R_{(\text{right})} - R_{(\text{left})}$$

Wendeschneidplatten sind in rechten und linken Klemhaltern verwendbar.
Indexable inserts can be used in right and left hand toolholders.

HM-Sorten
Carbide grades



Einstechen und Abstechen

Grooving and Parting Off



Wendeschneidplatte

Indexable insert

S224

mit Spanformrinne
with chip former

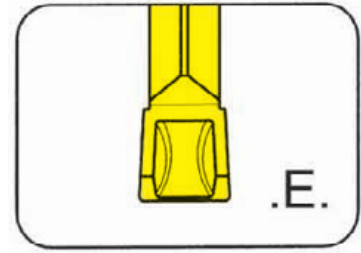

Stechtiefe bis Stechbreite	Depth of groove up to Width of groove	18 mm 2-4 mm
-------------------------------	--	-----------------

präzisionsgesintert
precision sintered

für Klemmhalter
for Toolholder

Typ H224
Type B224
BK224

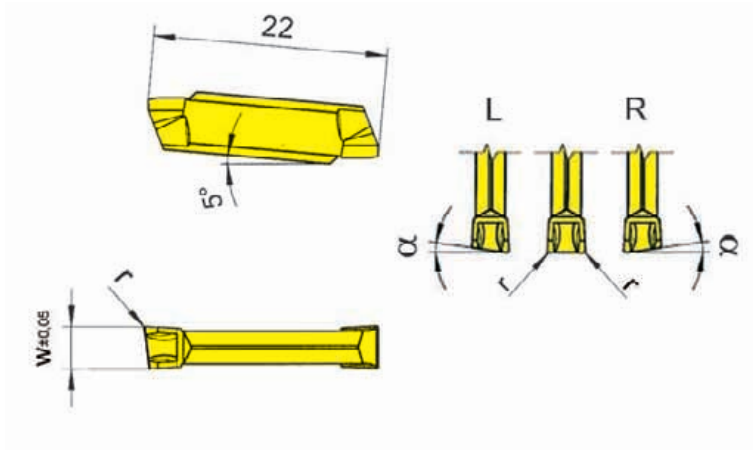

R = rechts wie gezeichnet
R = right hand version shown

L = links spiegelbildlich
L = left hand version

Wechselgenauigkeit
Länge ± 0,06 mm
Indexability length ± 0,06 mm

Bestellnummer Part number	w	r	α	Größe Size	AL96	AS62	TA43	TC92	TC93	TF43	TF45	T122	T125	TN32	TN35
S224.0200.E2	2,0	0,2	0°	01		▲		Δ	Δ	▲	▲				
R/LS224.0520.E2	2,0	0,2	5°	01		▲/▲		Δ/Δ	Δ/Δ	Δ/Δ	Δ/Δ				
S224.0250.E2	2,5	0,2	0°	02		▲		▲	Δ	▲	▲				
R/LS224.0525.E2	2,5	0,2	5°	02		▲/Δ		Δ/Δ	Δ/Δ	Δ/Δ	Δ/Δ				
S224.0300.E2	3,0	0,2	0°	03	Δ	▲	Δ	▲	Δ	▲	▲	▲	▲	Δ	Δ
S224.0300.E4	3,0	0,4	-	03	Δ	Δ		Δ	Δ	▲	▲		Δ	Δ	Δ
R/LS224.0530.E2	3,0	0,2	5°	03		▲/▲		Δ/Δ	Δ/Δ	▲/Δ	▲/▲				
S224.0400.E2	4,0	0,2	0°	04	Δ	▲		Δ	Δ	Δ	▲		Δ	Δ	Δ
S224.0400.E4	4,0	0,4	-	04	Δ	▲		Δ	Δ	Δ	▲		Δ	Δ	Δ
▲ ab Lager / on stock					P	●	●	●	●	●	●	●	●	●	●
Δ 4 Wochen / 4 weeks					M	-	-	-	-	-	●	-	●	-	●
x auf Anfrage / upon request					K	●	-	-	-	-	●	-	●	-	●
● empfohlen / recommended					N	●	-	-	-	-	●	-	●	-	●
○ bedingt einsetzbar / alternative recommendation					S	-	-	-	-	-	●	-	●	-	●
- nicht geeignet / not suitable					H	-	-	-	-	-	-	-	-	-	-
■ unbeschichtete HM-Sorten / uncoated grades															
■ beschichtete HM-Sorten / coated grades															
■ bestückt/Cermet / brazed/Cermet															

Abmessungen in mm
Dimensions in mm

Ausführung R oder L angeben
State R or L version

Weitere Abmessungen auf Anfrage
Further sizes upon request

Wendeschneidplatten sind in rechten und linken Klemmhaltern verwendbar.
Indexable inserts can be used in right and left hand toolholders.

HM-Sorten
Carbide grades

Einstechen und Abstechen

Grooving and Parting Off



Wendeschneidplatte

Indexable insert

S224

mit Spanformung
with chip forming

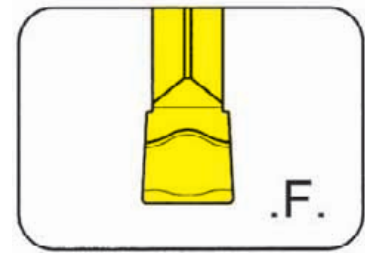

Stechtiefe bis Stechbreite	Depth of groove up to Width of groove	18 mm 2-4 mm
-------------------------------	--	-----------------

präzisionsgesintert
precision sintered

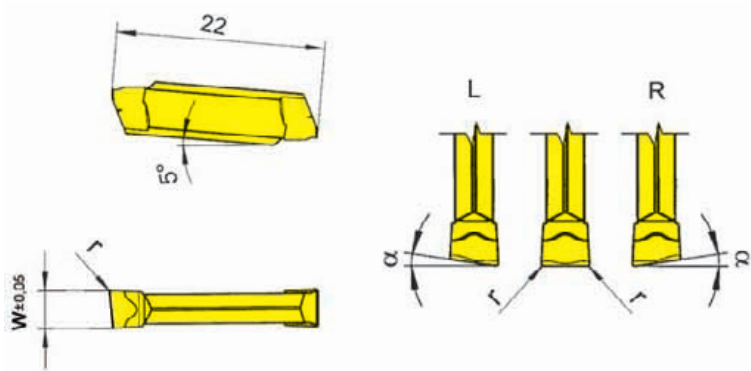

für Klemhalter
for Toolholder

Typ H224
Type B224
BK224

Wechselgenauigkeit
Länge ± 0,06 mm
Indexability length ± 0,06 mm

Bestellnummer Part number	w	r	α	Größe Size	AL96	TA43	TF42	TF43	TF45	TF46	TI22	TI25	TN32
S224.0200.F2	2,0	0,2	0°	01	Δ		Δ	▲	▲	▲	▲	▲	Δ
R/LS224.0520.F2	2,0	0,2	5°	01					▲/▲	▲/Δ			
S224.0250.F2	2,5	0,2	0°	02	Δ		Δ	Δ	▲	Δ	▲	Δ	Δ
R/LS224.0525.F2	2,5	0,2	5°	02				▲/Δ	▲/Δ				
S224.0300.F2	3,0	0,2	0°	03	Δ	Δ		▲	▲	▲	Δ	▲	Δ
R/LS224.0530.F2	3,0	0,2	5°	03				Δ/Δ	▲/▲		Δ/Δ		
S224.0400.F2	4,0	0,2	0°	04	Δ		Δ		▲		▲	Δ	Δ
▲ ab Lager / on stock Δ 4 Wochen / 4 weeks x auf Anfrage / upon request					P	●	●	●	●	●	●	●	●
● empfohlen / recommended					M	-	-	-	●	○	-	●	-
○ bedingt einsetzbar / alternative recommendation					K	●	-	-	-	●	-	●	-
- nicht geeignet / not suitable					N	●	-	-	-	●	-	●	-
■ unbeschichtete HM-Sorten / uncoated grades					S	-	-	-	-	○	-	●	-
■ beschichtete HM-Sorten / coated grades					H	-	-	-	-	-	-	-	-
■ bestückt/Cermet / brazed/Cermet													

Abmessungen in mm
Dimensions in mm

Ausführung R oder L angeben
State R or L version

Wendeschneidplatten sind in rechten und linken Klemmaltern verwendbar.
Indexable inserts can be used in right and left hand toolholders.

HM-Sorten
Carbide grades



Einstechen und Abstechen

Grooving and Parting Off



Wendeschneidplatte

Indexable insert

S224

mit Spanformung
with chip forming

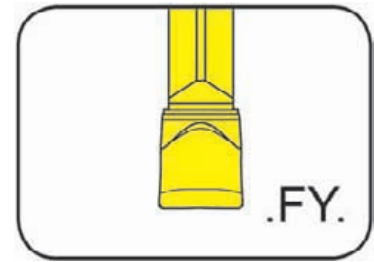

Stechtiefe bis Stechbreite	Depth of groove up to Width of groove	18 mm 2-3 mm
-------------------------------	--	-----------------

präzisionsgesintert
precision sintered

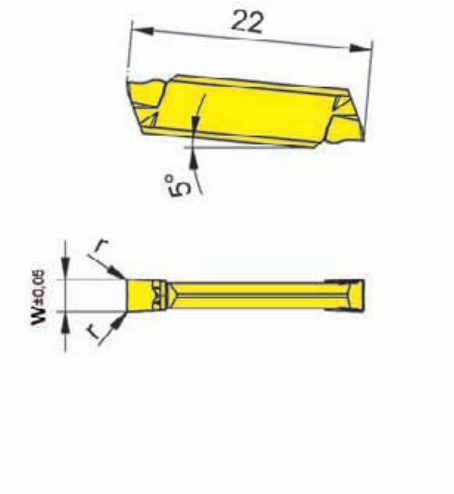

für Klemmhalter
for Toolholder

Typ H224
Type B224
BK224

Wechselgenauigkeit
Länge $\pm 0,06$ mm
Indexability length $\pm 0,06$ mm

G

Bestellnummer Part number	w	r	Größe Size	T125
S224.0200.FY2	2,0	0,2	01	▲
S224.0250.FY2	2,5	0,2	02	▲
S224.0300.FY2	3,0	0,2	03	▲

▲ ab Lager / on stock Δ 4 Wochen / 4 weeks x auf Anfrage / upon request

● empfohlen / recommended

o bedingt einsetzbar / alternative recommendation

- nicht geeignet / not suitable

■ unbeschichtete HM-Sorten / uncoated grades

■ beschichtete HM-Sorten / coated grades

■ bestückt/Cermet / brazed/Cermet

Abmessungen in mm

Dimensions in mm

Wendeschneidplatten sind in rechten und linken Klemmhaltern verwendbar.

Indexable inserts can be used in right and left hand toolholders.

Wendeschneidplatten sind in rechten und linken Klemmhaltern verwendbar.

Indexable inserts can be used in right and left hand toolholders.

P	•
M	•
K	•
N	•
S	•
H	-

HM-Sorten
Carbide grades

Einstechen und Abstechen

Grooving and Parting Off



Wendeschneidplatte

Indexable insert

S224

mit Spanformrinne
with chip former

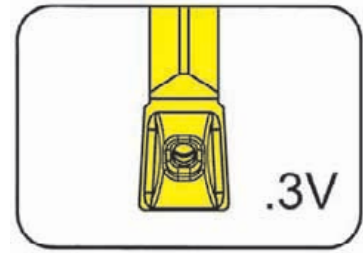

Stechbreite	Width of groove	3 mm
-------------	-----------------	------

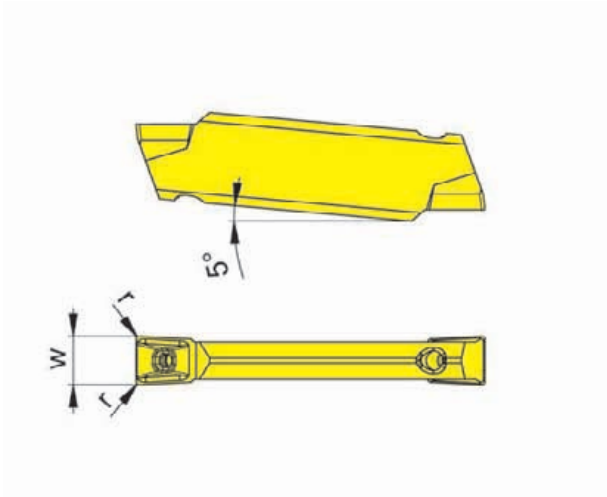

für Klemmhalter
for Toolholder

Typ H224
Type B224
BK224

Kühlmittelzufuhr durch die
Schneidplatte
Coolant supply through insert

Bestellnummer Part number	w	r	Größe Size	HP65
S224.0300.3V2.IK	3	0,2	03	▲
				P ●
				M ●
				K ●
				N ○
				S ●
				H -

▲ ab Lager / on stock Δ 4 Wochen / 4 weeks x auf Anfrage / upon request

● empfohlen / recommended

○ bedingt einsetzbar / alternative recommendation

- nicht geeignet / not suitable

□ unbeschichtete HM-Sorten / uncoated grades

■ beschichtete HM-Sorten / coated grades

■ bestückt/Cermet / brazed/Cermet

Abmessungen in mm

Dimensions in mm

Wendeschneidplatten sind in rechten und linken Klemmhaltern verwendbar.

Indexable inserts can be used in right and left hand toolholders.

HM-Sorten
Carbide grades



Gewindedrehen (außen) Vollprofil

Threading (external) Full profile



Wendeschneidplatte

Indexable insert

S224

Metrisches ISO-Gewinde
Metric ISO thread

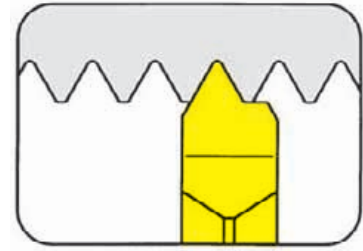

Steigung	Pitch	0,5-2 mm
----------	-------	----------

präzisionsgeschliffen
precision ground

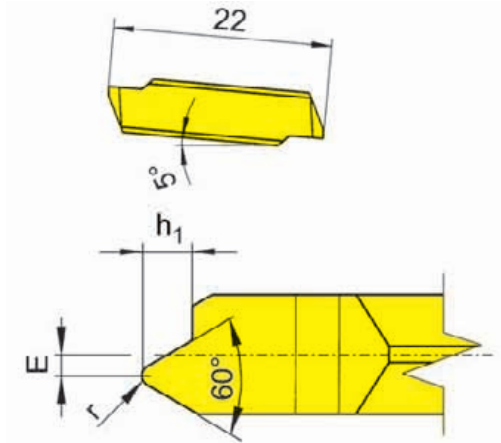

für Klemhalter
for Toolholder

Typ H224
Type B224
BK224

Wechselgenauigkeit
Länge $\pm 0,025$ mm
Indexability length $\pm 0,025$ mm

R = rechts wie gezeichnet
R = right hand version shown

L = links spiegelbildlich
L = left hand version

Bestellnummer Part number	P	E	r	h_1	Größe Size	TF45
R/LS224.0305.02	0,50	1,0	0,07	0,31	03	▲▲
R/LS224.0407.02	0,75	0,9	0,11	0,46	03	▲▲
R/LS224.0610.02	1,00	0,8	0,14	0,61	03	▲▲
R/LS224.0712.02	1,25	0,7	0,15	0,77	03	▲▲
R/LS224.0915.02	1,50	0,5	0,20	0,92	03	▲▲
R/LS224.1017.02	1,75	0,4	0,25	1,07	03	▲/Δ
R/LS224.1220.02	2,00	0,3	0,25	1,23	03	▲▲

▲ ab Lager / on stock Δ 4 Wochen / 4 weeks x auf Anfrage / upon request

● empfohlen / recommended

o bedingt einsetzbar / alternative recommendation

- nicht geeignet / not suitable

■ unbeschichtete HM-Sorten / uncoated grades

■ beschichtete HM-Sorten / coated grades

■ bestückt/Cermet / brazed/Cermet

P	•
M	•
K	•
N	•
S	•
H	-

Abmessungen in mm

Dimensions in mm

Ausführung R oder L angeben

State R or L version

HM-Sorten

Carbide grades

Keine Unterlegplatte erforderlich. Sämtliche HORN-Gewindeprofile sind mit einem **KEGELMANTEL-FREISCHLIFF** versehen.

No shims necessary. All HORN thread profiles are manufactured with **full ground radial clearance**.

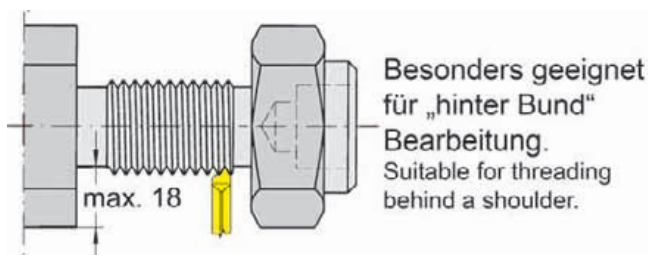

Gewindedrehen (außen) Vollprofil

Threading (external) Full profile



Wendeschneidplatte

Indexable insert

NS224

Whitworth Rohrgewinde
Whitworth pipe thread

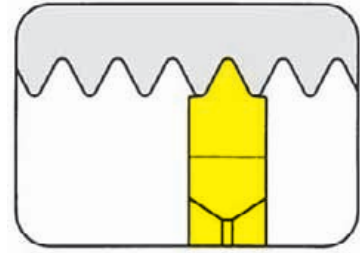

Gang pro Zoll	Threads per inch	11-28
---------------	------------------	-------

präzisionsgeschliffen
precision ground

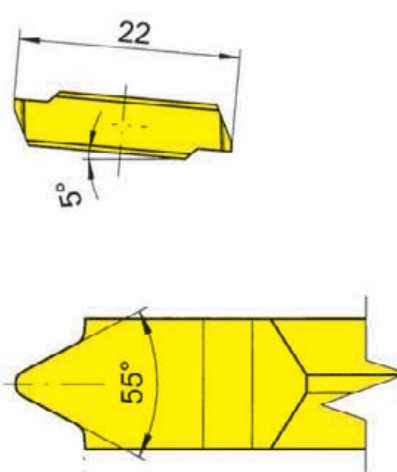

für Klemhalter
for Toolholder

Typ H224
Type B224
BK224

Wechselgenauigkeit
Länge ± 0,025 mm
Indexability length ± 0,025 mm



Bestellnummer Part number	TPI	Größe Size	TA45
NS224.5511.02	11	03	▲
NS224.5514.02	14	03	▲
NS224.5519.02	19	03	▲
NS224.5528.02	28	03	▲

▲ ab Lager / on stock Δ 4 Wochen / 4 weeks x auf Anfrage / upon request

● empfohlen / recommended

o bedingt einsetzbar / alternative recommendation

- nicht geeignet / not suitable

■ unbeschichtete HM-Sorten / uncoated grades

■ beschichtete HM-Sorten / coated grades

■ bestückt/Cermet / brazed/Cermet

P	•
M	•
K	•
N	•
S	•
H	-

Abmessungen in mm

Dimensions in mm

HM-Sorten
Carbide grades

Keine Unterlegplatte erforderlich. Sämtliche HORN-Gewindeprofile sind mit einem **KEGELMANTEL-FREISCHLIFF** versehen.

No shims necessary. All HORN thread profiles are manufactured with **full ground radial clearance**.

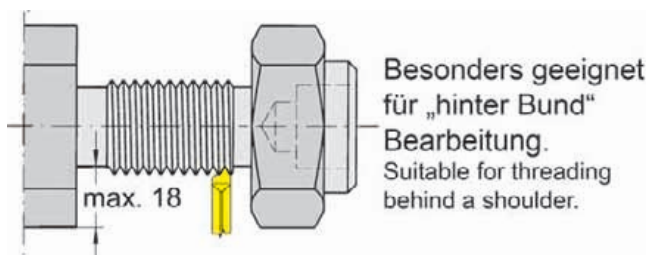



G

229/259



**Klemmhalter mit
Schneidplatten**

Stechbreite 2,5 - 10,0 mm

**Toolholder with
Inserts**

Width of groove 2,5 - 10,0 mm

H

Einstecken und Ausdrehen

Grooving and Boring



Einstecken (außen)
Grooving (external)

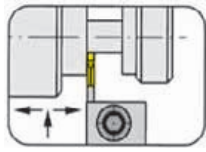

Seite/Page H2-H14,H16

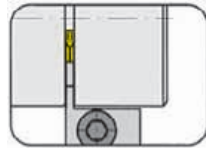

Seite/Page H15,H17

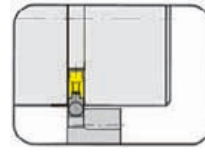

Seite/Page H18

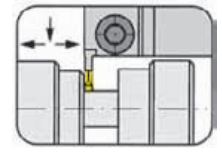

Seite/Page H19-H20

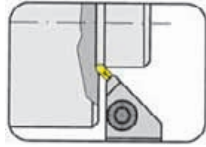

Seite/Page H21

Einstecken (innen)
Grooving (internal)

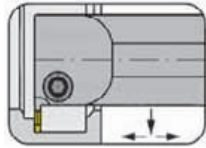

Seite/Page H22-H29

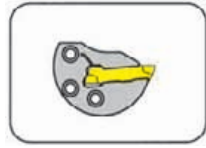

Seite/Page H30

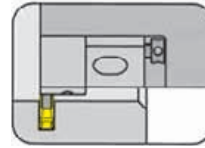

Seite/Page H31

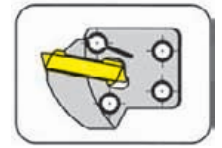

Seite/Page H32

Wendeschneidplatten
Indexable inserts
S229

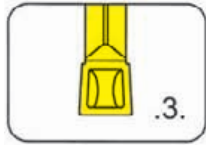

Seite/Page H34-H35

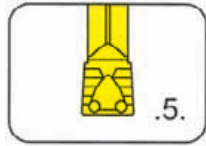

Seite/Page H36-H37

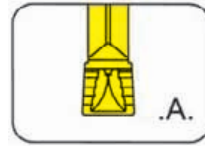

Seite/Page H38-H39

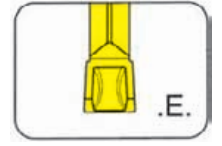

Seite/Page H40

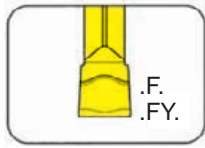

Seite/Page H43-H44

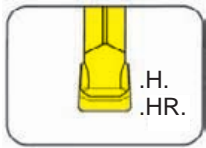

Seite/Page H43-H44

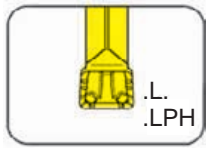

Seite/Page H45-H46

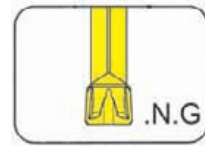

Seite/Page H47

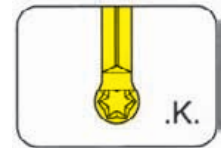

Seite/Page H48-H49

Wendeschneidplatten
Indexable inserts
229

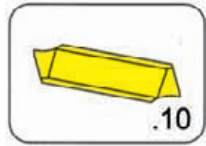

Seite/Page H50-H51

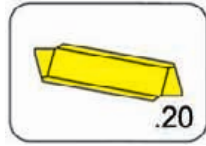

Seite/Page H52-H53

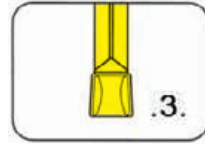

Seite/Page H54-H55

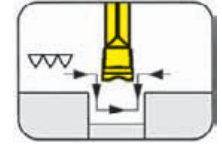

Seite/Page H56-H57



Seite/Page H58

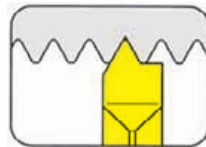

Seite/Page H59-H61

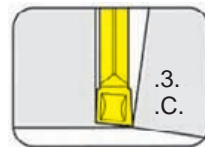

Seite/Page H62-H64

Klemmhalter
Toolholder
H259

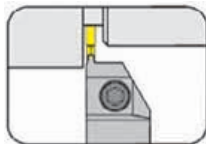

Seite/Page H65

Wendeschneidplatten
Indexable inserts
259

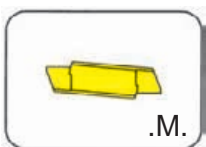

Seite/Page H66

Einstecken und Längsdrehen (außen)

Grooving and Side Turning (external)



Grundhalter

Basic toolholder

210

mit auswechselbarer Kassette
with changeable cassette

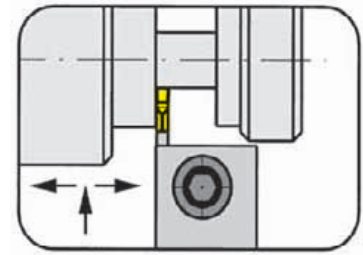

Stechtiefe bis Spannbereich	Depth of groove up to Clamping range	11 mm 3-8 mm
--------------------------------	---	-----------------

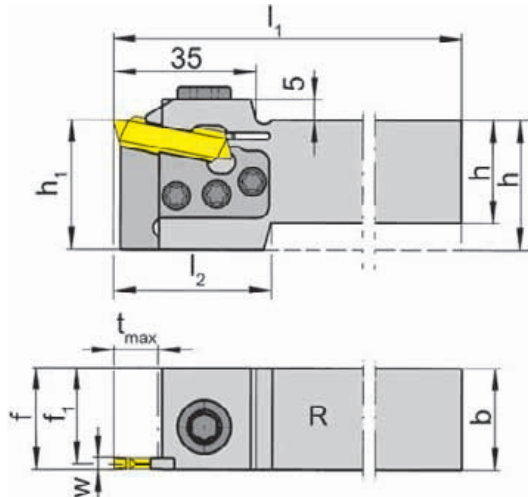

für Wendeschneidplatte
for Indexable insert

Typ 229
Type S229
N229

R = rechts wie gezeichnet
R = right hand version shown

L = links spiegelbildlich
L = left hand version

Bestellnummer Part number	h	b	l ₁	l ₂	h ₁	f ₁	f	t _{max}	Größe Size	Spannbereich Clamping range
R/L210.2525.K3	25	25	150	35	32	23,55	f ₁ +w/2	11	03	3,0-4,0
R/L210.3225.K3	32	25	170	-	32	23,55	f ₁ +w/2	11	03	3,0-4,0
R/L210.2525.K4	25	25	150	35	32	22,70	f ₁ +w/2	11	04	4,0-5,0
R/L210.3225.K4	32	25	150	-	32	22,70	f ₁ +w/2	11	04	4,0-5,0
R/L210.2525.K5	25	25	150	35	32	22,20	f ₁ +w/2	11	05	5,1-6,0
R/L210.3225.K5	32	25	170	-	32	22,20	f ₁ +w/2	11	05	5,1-6,0
R/L210.2525.K7	25	25	150	35	32	21,20	f ₁ +w/2	11	07	6,1-8,0
R/L210.3225.K7	32	25	170	-	32	21,20	f ₁ +w/2	11	07	6,1-8,0

Ausführung R oder L angeben
State R or L version

w siehe WSP
w see indexable inserts

Abmessungen in mm
Dimensions in mm

Weitere Abmessungen auf Anfrage
Further sizes upon request

Das Anzugsdrehmoment der Schrauben finden Sie in den Technischen Hinweisen.
For torque specification of the screw, please see Technical Instructions.

Ersatzteile

Spare Parts

Grundhalter Basic toolholder	Spannschraube Screw	Inbus-Schlüssel Wrench	Kassette Cassette	TORX PLUS®-Schlüssel TORX PLUS® Wrench
R/L210...K3	030.0518T20P	SW6,0 DIN911	NK210.32.03	T20PQ
R/L210...K4	030.0518T20P	SW6,0 DIN911	NK210.32.04	T20PQ
R/L210...K5	030.0518T20P	SW6,0 DIN911	NK210.32.05	T20PQ
R/L210...K7	030.0518T20P	SW6,0 DIN911	NK210.32.07	T20PQ



Einstecken und Längsdrehen (außen)

Grooving and Side Turning (external)



Grundhalter

Basic toolholder

210

mit auswechselbarer Kassette
with changeable cassette

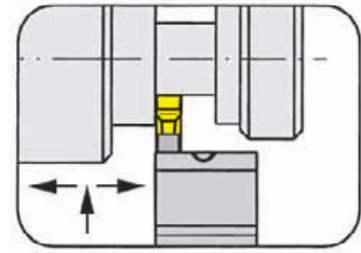

Stechtiefe bis Spannbereich	Depth of groove up to Clamping range	11 mm 8,1-10,4 mm
--------------------------------	---	----------------------

für Wendeschneidplatte
for Indexable insert

Typ 229
Type S229
N229

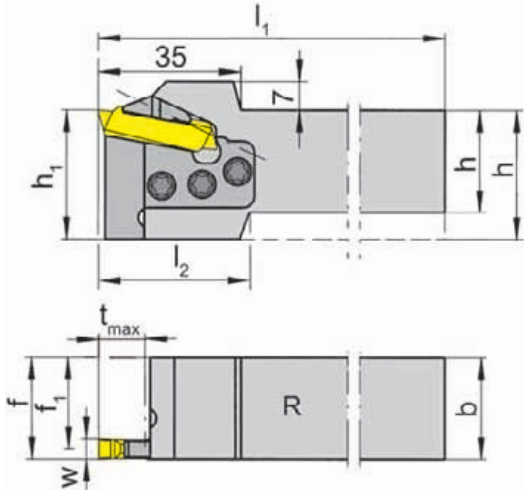

R = rechts wie gezeichnet
R = right hand version shown

L = links spiegelbildlich
L = left hand version

Bestellnummer Part number	h	b	l ₁	l ₂	h ₁	f ₁	f	t _{max}	Größe Size	Spannbereich Clamping range
R/L210.2525.K9	25	25	150	35	32	20,2	f ₁ +w/2	11	09	8,1-10,4
R/L210.3225.K9	32	25	170	-	32	20,2	f ₁ +w/2	11	09	8,1-10,4

Ausführung R oder L angeben
State R or L version

w siehe WSP
w see indexable inserts

Abmessungen in mm
Dimensions in mm

Weitere Abmessungen auf Anfrage
Further sizes upon request

Hinweis:

Bitte beachten Sie die Zuordnung der Spannelemente.

Note:

Please note type of clamp.

Das Anzugsdrehmoment der Schrauben finden Sie in den Technischen Hinweisen.

For torque specification of the screw, please see Technical Instructions.

Ersatzteile

Spare Parts

Grundhalter Basic toolholder	Spannschraube Screw	Kassette Cassette	Spannelement Clamping element	TORX PLUS®-Schlüssel TORX PLUS® Wrench
L210...	030.0518T20P	NK210.32.09	L218.9	T15PQ
R210...	030.0518T20P	NK210.32.09	R218.9	T15PQ

Einstechen und Längsdrehen (außen)

Grooving and Side Turning (external)



Klemmhalter

Toolholder

210

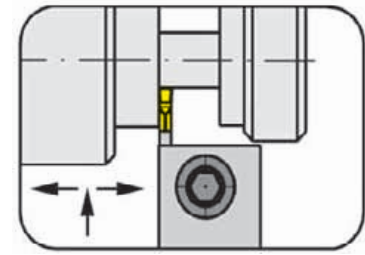

Stechtiefe bis
Spannbereich

Depth of groove up to
Clamping range

11 mm
2,5-6 mm

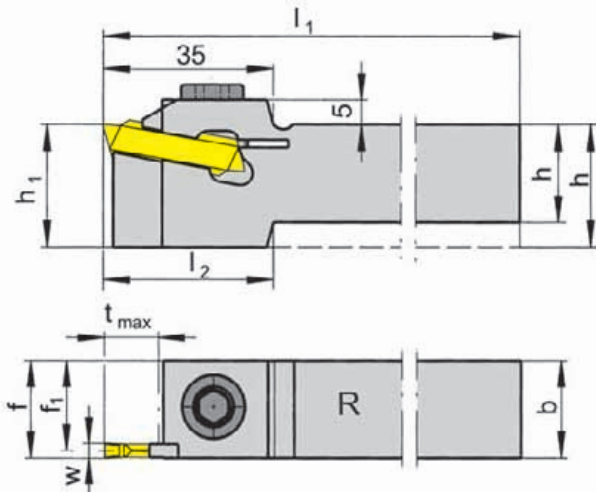

für Wendeschneidplatte
for Indexable insert

Typ 229
Type S229
N229

R = rechts wie gezeichnet
R = right hand version shown

L = links spiegelbildlich
L = left hand version

Bestellnummer Part number	h	b	l ₁	l ₂	h ₁	f ₁	f	t _{max}	Größe Size	Spannbereich Clamping range
R/L210.2020.02	20	20	150	35	25	18,55	f ₁ +w/2	11	02	2,5-3,0
R/L210.2525.02	25	25	150	-	25	23,55	f ₁ +w/2	11	02	2,5-3,0
R/L210.1616.03	16	16	150	45	25	14,55	f ₁ +w/2	11	03	3,0-4,0
R/L210.2020.03	20	20	150	35	25	18,55	f ₁ +w/2	11	03	3,0-4,0
R/L210.2525.03	25	25	150	-	25	23,55	f ₁ +w/2	11	03	3,0-4,0
R/L210.3225.03	32	25	170	-	32	23,55	f ₁ +w/2	11	03	3,0-4,0
R/L210.2020.04	20	20	150	35	25	17,70	f ₁ +w/2	11	04	4,0-5,0
R/L210.2525.04	25	25	150	-	25	22,70	f ₁ +w/2	11	04	4,0-5,0
R/L210.3225.04	32	25	170	-	32	22,70	f ₁ +w/2	11	04	4,0-5,0
R/L210.2020.05	20	20	150	35	25	17,20	f ₁ +w/2	11	05	5,1-6,0
R/L210.2525.05	25	25	150	-	25	22,20	f ₁ +w/2	11	05	5,1-6,0
R/L210.3225.05	32	25	170	-	32	22,20	f ₁ +w/2	11	05	5,1-6,0

Ausführung R oder L angeben
State R or L version

w siehe WSP
w see indexable inserts

Abmessungen in mm
Dimensions in mm

R/L 210...02 max. Stechtiefe bis Ø 150 mm

R/L 210...02 max. depth of groove up to Ø 150 mm

Weitere Abmessungen auf Anfrage

Further sizes upon request

Das Anzugsdrehmoment der Schrauben finden Sie in den Technischen Hinweisen.

For torque specification of the screw, please see Technical Instructions.

Ersatzteile

Spare Parts

Klemmhalter Toolholder	Spannschraube Screw	Inbus-Schlüssel Wrench
R/L210...	218.3	SW6,0 DIN911

H

Einstecken und Längsdrehen (außen)

Grooving and Side Turning (external)



Klemmhalter

Toolholder

210

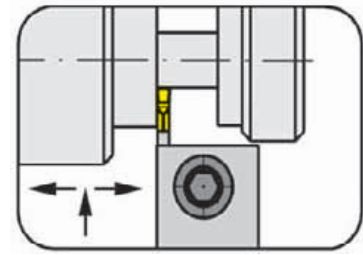

Stechtiefe bis
Spannbereich

Depth of groove up to
Clamping range

11 mm
6,1-8 mm

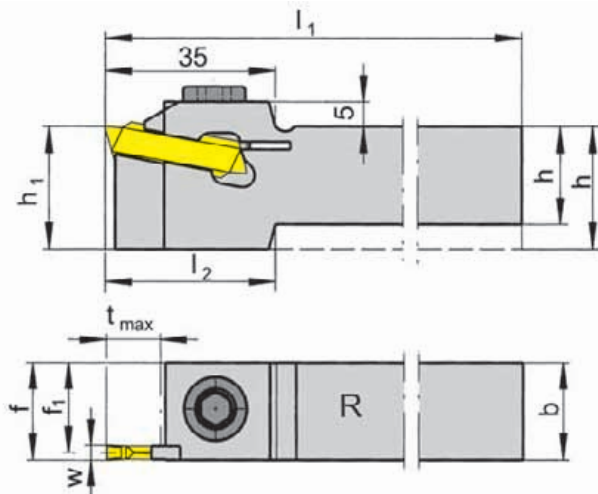

für Wendeschneidplatte
for Indexable insert

Typ 229
Type S229
N229

R = rechts wie gezeichnet
R = right hand version shown

L = links spiegelbildlich
L = left hand version

Bestellnummer Part number	h	b	l ₁	l ₂	h ₁	f ₁	f	t _{max}	Größe Size	Spannbereich Clamping range
R/L210.2020.07	20	20	150	35	25	16,2	f ₁ +w/2	11	07	6,1-8,0
R/L210.2525.07	25	25	150	-	25	21,2	f ₁ +w/2	11	07	6,1-8,0
R/L210.3225.07	32	25	170	-	32	21,2	f ₁ +w/2	11	07	6,1-8,0
R/L210.2020.08	20	20	150	35	25	16,2	f ₁ +w/2	11	08	7,6-8,0
R/L210.2525.08	25	25	150	-	25	21,2	f ₁ +w/2	11	08	7,6-8,0

Ausführung R oder L angeben
State R or L version

w siehe WSP
w see indexable inserts

Abmessungen in mm
Dimensions in mm

Weitere Abmessungen auf Anfrage
Further sizes upon request

Das Anzugsdrehmoment der Schrauben finden Sie in den Technischen Hinweisen.
For torque specification of the screw, please see Technical Instructions.

Ersatzteile

Spare Parts

Klemmhalter Toolholder	Spannschraube Screw	Inbus-Schlüssel Wrench
R/L210...	218.3	SW6,0 DIN911

Einstecken und Längsdrehen (außen)

Grooving and Side Turning (external)



Klemmhalter

Toolholder

210

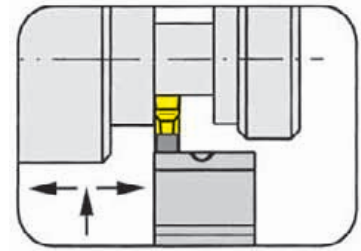

Stechtiefe bis Spannbereich	Depth of groove up to Clamping range	11 mm 8,1-10,4 mm
--------------------------------	---	----------------------

für Wendeschneidplatte
for Indexable insert

Typ 229
Type S229
N229

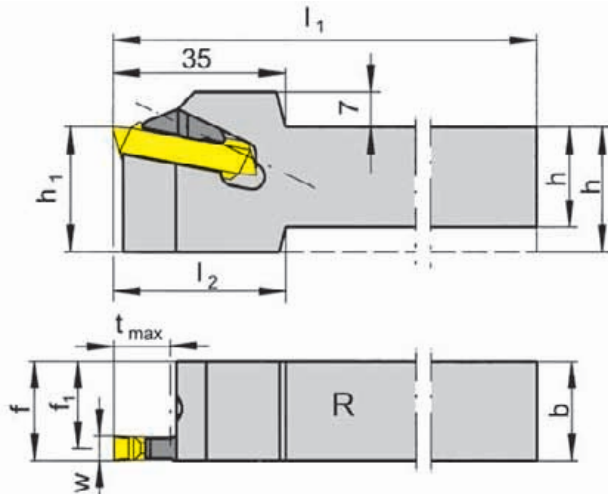

R = rechts wie gezeichnet
R = right hand version shown

L = links spiegelbildlich
L = left hand version

Bestellnummer Part number	h	b	l ₁	l ₂	h ₁	f ₁	f	t _{max}	Größe Size	Spannbereich Clamping range
R/L210.2020.09	20	20	150	35	25	15,2	f ₁ +w/2	11	09	8,1-10,4
R/L210.2525.09	25	25	150	-	25	20,2	f ₁ +w/2	11	09	8,1-10,4
R/L210.3225.09	32	25	170	-	32	20,2	f ₁ +w/2	11	09	8,1-10,4

Ausführung R oder L angeben
State R or L version

w siehe WSP
w see indexable inserts

Abmessungen in mm
Dimensions in mm

Weitere Abmessungen auf Anfrage
Further sizes upon request

Hinweis:

Bitte beachten Sie die Zuordnung der Spannelemente.

Note:

Please note type of clamp.

Das Anzugsdrehmoment der Schrauben finden Sie in den Technischen Hinweisen.

For torque specification of the screw, please see Technical Instructions.

Ersatzteile

Spare Parts

Klemmhalter Toolholder	Spannelement Clamping element	TORX PLUS®-Schlüssel TORX PLUS® Wrench
L210...	L218.9	T15PQ
R210...	R218.9	T15PQ



Einstecken und Längsdrehen (außen)

Grooving and Side Turning (external)



Grundhalter

Basic toolholder

218

mit auswechselbarer Kassette
with changeable cassette

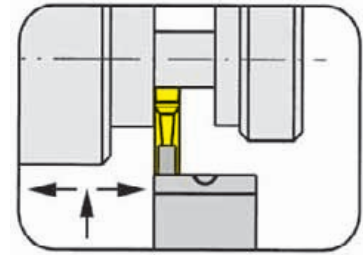

Stechtiefe bis Spannbereich	Depth of groove up to Clamping range	18 mm 8,1-10,4 mm
--------------------------------	---	----------------------

für Wendeschneidplatte
for Indexable insert

Typ 229
Type S229
N229

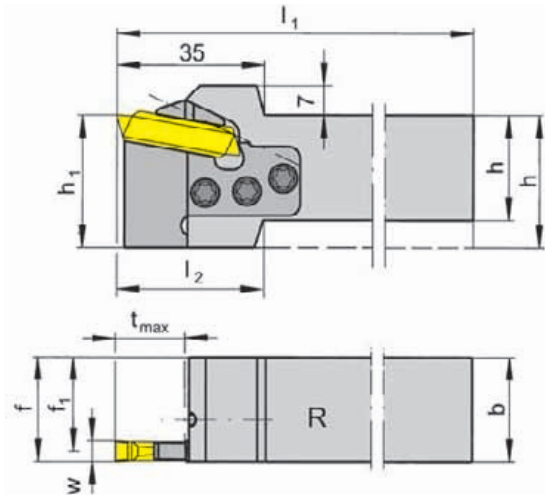

R = rechts wie gezeichnet
R = right hand version shown

L = links spiegelbildlich
L = left hand version

Bestellnummer Part number	h	b	l ₁	l ₂	h ₁	f ₁	f	t _{max}	Größe Size	Spannbereich Clamping range
R/L218.2525.K9	25	25	150	48	32	20,2	f ₁ +w/2	18	09	8,1-10,4
R/L218.3225.K9	32	25	170	-	32	20,2	f ₁ +w/2	18	09	8,1-10,4

Ausführung R oder L angeben
State R or L version

w siehe WSP
w see indexable inserts

Abmessungen in mm
Dimensions in mm

Weitere Abmessungen auf Anfrage
Further sizes upon request

Hinweis:

Bitte beachten Sie die Zuordnung der Spannelemente.

Note:

Please note type of clamp.

Das Anzugsdrehmoment der Schrauben finden Sie in den Technischen Hinweisen.

For torque specification of the screw, please see Technical Instructions.

Ersatzteile

Spare Parts

Grundhalter Basic toolholder	Spannschraube Screw	Kassette Cassette	Spannelement Clamping element	TORX PLUS®-Schlüssel TORX PLUS® Wrench
L218...	030.0518T20P	NK218.32.09	L218.9	T15PQ
R218...	030.0518T20P	NK218.32.09	R218.9	T15PQ

Einstecken und Längsdrehen (außen)

Grooving and Side Turning (external)



Grundhalter

Basic toolholder

218

mit auswechselbarer Kassette
with changeable cassette

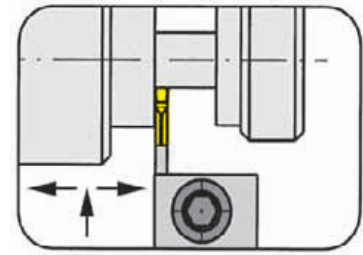

Stechtiefe bis
Spannbereich

Depth of groove up to
Clamping range

18 mm
3-8 mm

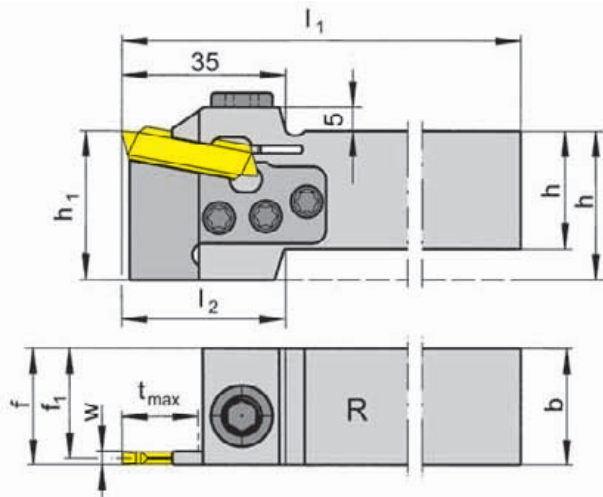

R = rechts wie gezeichnet
R = right hand version shown

L = links spiegelbildlich
L = left hand version

für Wendeschneidplatte
for Indexable insert

Typ 229
Type S229
N229

Bestellnummer Part number	h	b	l ₁	l ₂	h ₁	f ₁	f	t _{max}	Größe Size	Spannbereich Clamping range
R/L218.2525.K3	25	25	150	35	32	23,55	f ₁ +w/2	18	03	3,0-4,0
R/L218.3225.K3	32	25	170	-	32	23,55	f ₁ +w/2	18	03	3,0-4,0
R/L218.2525.K4	25	25	150	35	32	22,70	f ₁ +w/2	18	04	4,0-5,0
R/L218.3225.K4	32	25	170	-	32	22,70	f ₁ +w/2	18	04	4,0-5,0
R/L218.2525.K5	25	25	150	35	32	22,20	f ₁ +w/2	18	05	5,1-6,0
R/L218.3225.K5	32	25	170	-	32	22,20	f ₁ +w/2	18	05	5,1-6,0
R/L218.2525.K7	25	25	150	35	32	21,20	f ₁ +w/2	18	07	6,1-8,0
R/L218.3225.K7	32	25	170	-	32	21,20	f ₁ +w/2	18	07	6,1-8,0

Ausführung R oder L angeben
State R or L version

w siehe WSP
w see indexable inserts

Abmessungen in mm
Dimensions in mm

Weitere Abmessungen auf Anfrage
Further sizes upon request

Das Anzugsdrehmoment der Schrauben finden Sie in den Technischen Hinweisen.
For torque specification of the screw, please see Technical Instructions.

Ersatzteile

Spare Parts

Grundhalter Basic toolholder	Spannschraube Screw	Inbus-Schlüssel Wrench	Kassette Cassette	TORX PLUS®-Schlüssel TORX PLUS® Wrench
R/L218...K3	030.0518T20P	SW6,0 DIN911	NK218.32.03	T20PQ
R/L218...K4	030.0518T20P	SW6,0 DIN911	NK218.32.04	T20PQ
R/L218...K5	030.0518T20P	SW6,0 DIN911	NK218.32.05	T20PQ
R/L218...K7	030.0518T20P	SW6,0 DIN911	NK218.32.07	T20PQ

Einstecken und Längsdrehen (außen)

Grooving and Side Turning (external)



Klemmhalter

Toolholder

218

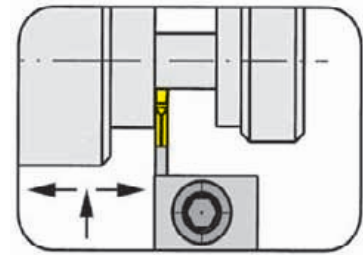

Stechtiefe bis Spannbereich	Depth of groove up to Clamping range	18 mm 2,5-6 mm
-----------------------------	--------------------------------------	-------------------

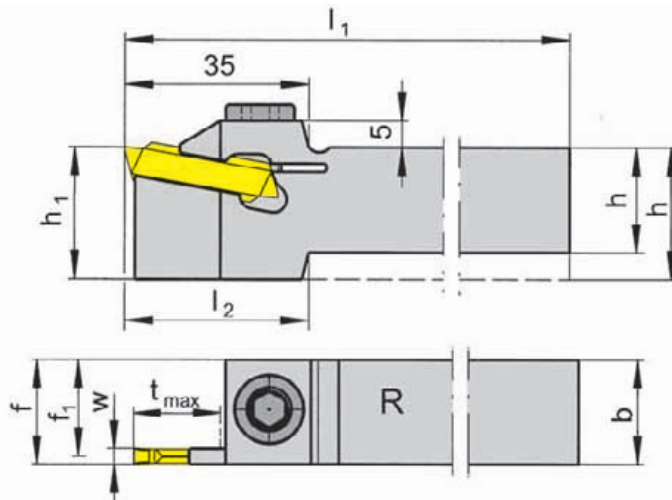

für Wendeschneidplatte
for Indexable insert

Typ 229
Type S229
N229

R = rechts wie gezeichnet
R = right hand version shown

L = links spiegelbildlich
L = left hand version

Bestellnummer Part number	h	b	l ₁	l ₂	h ₁	f ₁	f	t _{max}	Größe Size	Spannbereich Clamping range
R/L218.2020.02	20	20	150	35	25	18,55	f ₁ +w/2	18	02	2,5-3,0
R/L218.2525.02	25	25	150	-	25	23,55	f ₁ +w/2	18	02	2,5-3,0
R/L218.1616.03	16	16	150	45	25	14,55	f ₁ +w/2	18	03	3,0-4,0
R/L218.2020.03	20	20	150	35	25	18,55	f ₁ +w/2	18	03	3,0-4,0
R/L218.2525.03	25	25	150	-	25	23,55	f ₁ +w/2	18	03	3,0-4,0
R/L218.3225.03	32	25	170	-	32	23,55	f ₁ +w/2	18	03	3,0-4,0
R/L218.2020.04	20	20	150	35	25	17,70	f ₁ +w/2	18	04	4,0-5,0
R/L218.2525.04	25	25	150	-	25	22,70	f ₁ +w/2	18	04	4,0-5,0
R/L218.3225.04	32	25	170	-	32	22,70	f ₁ +w/2	18	04	4,0-5,0
R/L218.2020.05	20	20	150	35	25	17,20	f ₁ +w/2	18	05	5,1-6,0
R/L218.2525.05	25	25	150	-	25	22,20	f ₁ +w/2	18	05	5,1-6,0
R/L218.3225.05	32	25	170	-	32	22,20	f ₁ +w/2	18	05	5,1-6,0

Ausführung R oder L angeben
State R or L version

w siehe WSP
w see indexable inserts

Abmessungen in mm
Dimensions in mm

R/L 218...02 max. Stechtiefe bis Ø 80 mm

R/L 218...02 max. depth of groove up to Ø 80 mm

Weitere Abmessungen auf Anfrage

Further sizes upon request

Das Anzugsdrehmoment der Schrauben finden Sie in den Technischen Hinweisen.

For torque specification of the screw, please see Technical Instructions.

Ersatzteile

Spare Parts

Klemmhalter Toolholder	Spannschraube Screw	Inbus-Schlüssel Wrench
R/L218...	218.3	SW6,0 DIN911

Einstecken und Längsdrehen (außen)

Grooving and Side Turning (external)



Klemmhalter

Toolholder

218

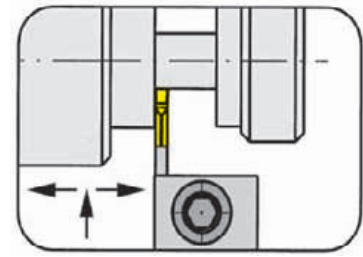

Stechtiefe bis Spannbereich	Depth of groove up to Clamping range	18 mm 2,5-4 mm
--------------------------------	---	-------------------

für Wendeschneidplatte
for Indexable insert

Typ 229
Type S229
N229

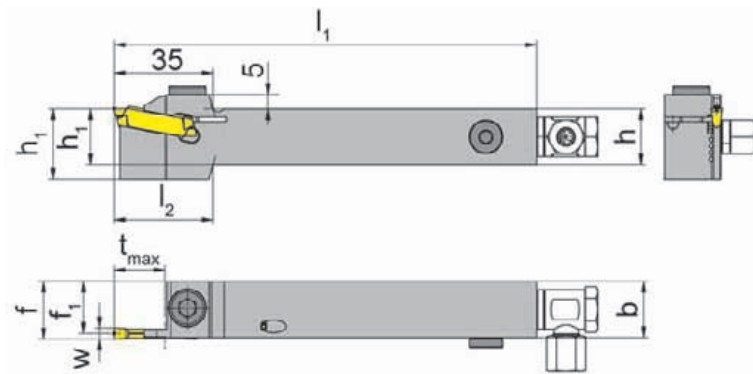

R = rechts wie gezeichnet
R = right hand version shown

L = links spiegelbildlich
L = left hand version

mit innerer
Kühlmittelzufuhr
with through coolant supply

Bestellnummer Part number	h	b	l ₁	l ₂	h ₁	f ₁	f	t _{max}	Größe Size	Spannbereich Clamping range
R/L218.2020.02.IK	20	20	150	35	25	18,55	f ₁ +w/2	18	02	2,5-3,0
R/L218.2525.02.IK	25	25	150	-	25	23,55	f ₁ +w/2	18	02	2,5-3,0
R/L218.1616.03.IK	16	16	150	45	25	14,55	f ₁ +w/2	18	03	3,0-4,0
R/L218.2020.03.IK	20	20	150	35	25	18,55	f ₁ +w/2	18	03	3,0-4,0
R/L218.2525.03.IK	25	25	150	-	25	23,55	f ₁ +w/2	18	03	3,0-4,0
R/L218.3225.03.IK	32	25	170	-	32	23,55	f ₁ +w/2	18	03	3,0-4,0

Ausführung R oder L angeben
State R or L version

w siehe WSP
w see indexable inserts

Abmessungen in mm
Dimensions in mm

R/L 218...02 max. Stechtiefe bis Ø 80 mm
R/L 218...02 max. depth of groove up to Ø 80 mm

Weitere Abmessungen auf Anfrage
Further sizes upon request

Das Anzugsdrehmoment der Schrauben finden Sie in den Technischen Hinweisen.
For torque specification of the screw, please see Technical Instructions.

Ersatzteile

Spare Parts

Klemmhalter Toolholder	Spannschraube Screw	Dichtstopfen Sealing plug	Inbus-Schlüssel Wrench	Kühlmittelanschluss Coolant supply
R/L218...	218.3	004.00.26	SW6,0 DIN911	004.00.16



Einstechen und Abstechen

Grooving and Parting Off



Klemmhalter

Toolholder

218

mit Schraubklemmung
with screwed clamping

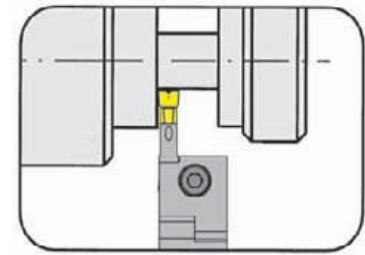

Stechtiefe bis Stechbreite	Depth of groove up to Width of groove	18 mm 3-6 mm
-------------------------------	--	-----------------

für Wendeschneidplatte
for Indexable insert

Typ S229
Type 229
N229

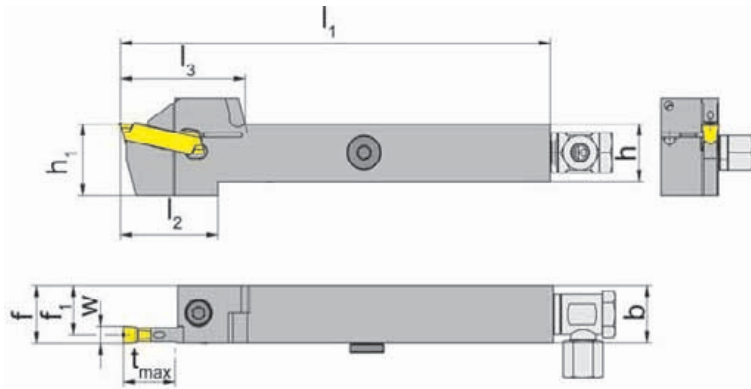

R = rechts wie gezeichnet
R = right hand version shown

L = links spiegelbildlich
L = left hand version

mit innerer
Kühlmittelzufuhr
with through coolant supply

Bestellnummer Part number	h	b	l ₁	l ₂	l ₃	h ₁	f ₁	f	t _{max}	Größe Size
R/L218.1616.0.03.IK	16	16	150	37	43,5	25	14,55	f ₁ +w/2	18	03
R/L218.2020.0.03.IK	20	20	150	34	43,5	25	18,55	f ₁ +w/2	18	03
R/L218.2525.0.03.IK	25	25	150	32	43,5	32	23,55	f ₁ +w/2	18	03
R/L218.2020.0.04.IK	20	20	150	34	43,5	25	17,70	f ₁ +w/2	18	04
R/L218.2020.0.05.IK	20	20	150	34	43,5	25	17,20	f ₁ +w/2	18	05
R/L218.2525.0.04.IK	25	25	150	32	43,5	32	22,70	f ₁ +w/2	18	04
R/L218.2525.0.05.IK	25	25	150	32	43,5	32	22,20	f ₁ +w/2	18	05

Ausführung R oder L angeben
State R or L version

w siehe WSP
w see indexable inserts

Abmessungen in mm
Dimensions in mm

Weitere Abmessungen auf Anfrage
Further sizes upon request

Das Anzugsdrehmoment der Schrauben finden Sie in den Technischen Hinweisen.
For torque specification of the screw, please see Technical Instructions.

Ersatzteile

Spare Parts

Klemmhalter Toolholder	Dichtstopfen Sealing plug	Kühlmittelanschluss Coolant supply	Spannschraube Screw	TORX PLUS®-Schlüssel TORX PLUS® Wrench
R/L218...	004.00.26	004.00.16	6.23T25P	T25PQ

Einstecken und Längsdrehen (außen)

Grooving and Side Turning (external)



Klemmhalter

Toolholder

218

Stechtiefe bis Spannbereich	Depth of groove up to Clamping range	18 mm 6,1-8 mm
--------------------------------	---	-------------------

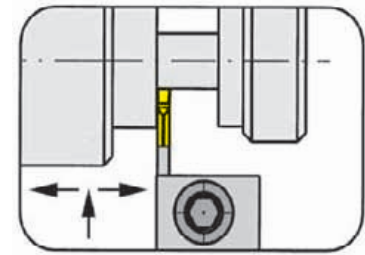

für Wendeschneidplatte
for Indexable insert

Typ 229
Type S229
N229

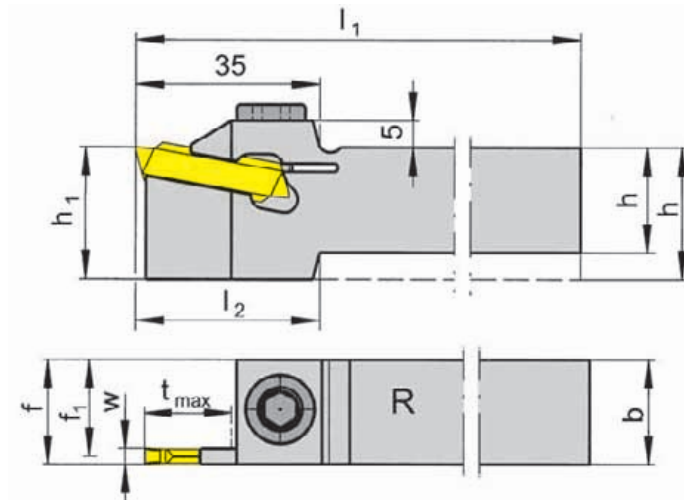

R = rechts wie gezeichnet
R = right hand version shown

L = links spiegelbildlich
L = left hand version

Bestellnummer Part number	h	b	l ₁	l ₂	h ₁	f ₁	f	t _{max}	Größe Size	Spannbereich Clamping range
R/L218.2020.07	20	20	150	35	25	16,2	f ₁ +w/2	18	07	6,1-8,0
R/L218.2525.07	25	25	150	-	25	21,2	f ₁ +w/2	18	07	6,1-8,0
R/L218.3225.07	32	25	170	-	32	21,2	f ₁ +w/2	18	07	6,1-8,0
R/L218.2525.08	25	25	150	-	25	21,2	f ₁ +w/2	18	08	7,6-8,0

Ausführung R oder L angeben
State R or L version

w siehe WSP
w see indexable inserts

Abmessungen in mm
Dimensions in mm

Weitere Abmessungen auf Anfrage
Further sizes upon request

Das Anzugsdrehmoment der Schrauben finden Sie in den Technischen Hinweisen.
For torque specification of the screw, please see Technical Instructions.

Ersatzteile

Spare Parts

Klemmhalter Toolholder	Spannschraube Screw	Inbus-Schlüssel Wrench
R/L218...	218.3	SW6,0 DIN911



Einstecken und Längsdrehen (außen)

Grooving and Side Turning (external)



Klemmhalter

Toolholder

218

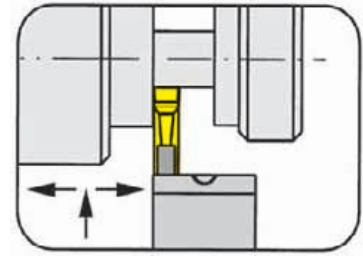

Stechtiefe bis Spannbereich	Depth of groove up to Clamping range	18 mm 8,1-10,4 mm
--------------------------------	---	----------------------

für Wendeschneidplatte
for Indexable insert

Typ S229
Type 229
N229

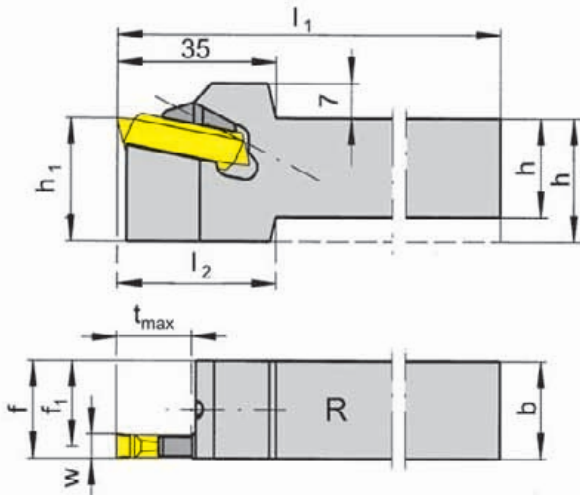

R = rechts wie gezeichnet
R = right hand version shown

L = links spiegelbildlich
L = left hand version

Bestellnummer Bestellnummer	h	b	l ₁	l ₂	h ₁	f ₁	f	t _{max}	Größe Size	Spannbereich Clamping range
R/L218.2020.09	20	20	150	35	25	15,2	f ₁ +w/2	18	09	8,1-10,4
R/L218.2525.09	25	25	150	-	25	20,2	f ₁ +w/2	18	09	8,1-10,4
R/L218.3225.09	32	25	170	-	32	20,2	f ₁ +w/2	18	09	8,1-10,4

Ausführung R oder L angeben
State R or L version

w siehe WSP
w see indexable inserts

Abmessungen in mm
Dimensions in mm

Weitere Abmessungen auf Anfrage
Further sizes upon request

Hinweis:

Bitte beachten Sie die Zuordnung der Spannelemente.

Note:

Please note type of clamp.

Das Anzugsdrehmoment der Schrauben finden Sie in den Technischen Hinweisen.

For torque specification of the screw, please see Technical Instructions.

Ersatzteile

Spare Parts

Klemmhalter Toolholder	Spannelement Clamping element	TORX PLUS®-Schlüssel TORX PLUS® Wrench
L218...	L218.9	T15PQ
R218...	R218.9	T15PQ

Einstecken (außen)

Grooving (external)



Klemmhalter

Toolholder

226

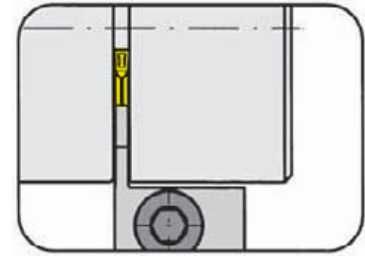

Stechtiefe bis Spannbereich	Depth of groove up to Clamping range	25 mm 3-6 mm
-----------------------------	--------------------------------------	-----------------

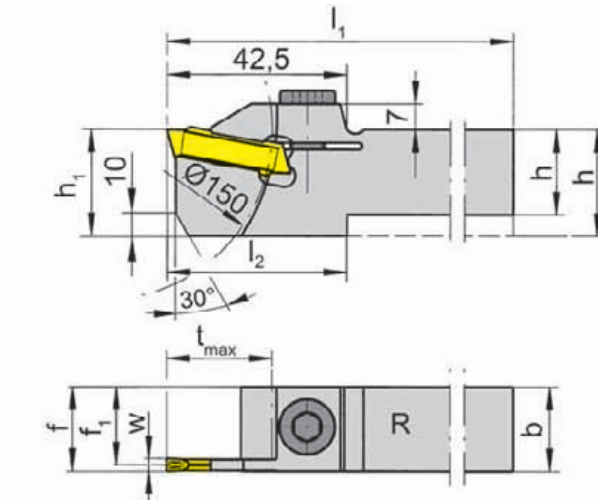

für Wendeschneidplatte
for Indexable insert

Typ 229
Type S229
N229

R = rechts wie gezeichnet
R = right hand version shown

L = links spiegelbildlich
L = left hand version

Bestellnummer Part number	h	b	l ₁	l ₂	h ₁	f ₁	f	t _{max}	Größe Size	Spannbereich Clamping range
R/L226.1616.03	16	16	150	52,5	32	18,55	f ₁ +w/2	25	03	3,0-4,0
R/L226.2020.03	20	20	150	42,5	32	18,55	f ₁ +w/2	25	03	3,0-4,0
R/L226.2525.03	25	25	150	-	32	23,55	f ₁ +w/2	25	03	3,0-4,0
R/L226.3225.03	32	25	170	-	32	23,55	f ₁ +w/2	25	03	3,0-4,0
R/L226.1616.04	16	16	150	52,5	32	13,70	f ₁ +w/2	25	04	4,0-5,0
R/L226.2020.04	20	20	150	42,5	32	17,70	f ₁ +w/2	25	04	4,0-5,0
R/L226.2525.04	25	25	150	-	32	22,70	f ₁ +w/2	25	04	4,0-5,0
R/L226.3225.04	32	25	170	-	32	22,70	f ₁ +w/2	25	04	4,0-5,0
R/L226.2020.05	20	20	150	42,5	32	17,20	f ₁ +w/2	25	05	5,1-6,0
R/L226.2525.05	25	25	150	42,5	32	22,20	f ₁ +w/2	25	05	5,1-6,0
R/L226.3225.05	32	25	170	-	32	22,20	f ₁ +w/2	25	05	5,1-6,0

Ausführung R oder L angeben
State R or L version

w siehe WSP
w see indexable inserts

Abmessungen in mm
Dimensions in mm

Weitere Abmessungen auf Anfrage
Further sizes upon request

Das Anzugsdrehmoment der Schrauben finden Sie in den Technischen Hinweisen.
For torque specification of the screw, please see Technical Instructions.

Ersatzteile

Spare Parts

Klemmhalter Toolholder	Spannschraube Screw	Inbus-Schlüssel Wrench
R/L226...	218.3	SW6,0 DIN911

H

Einstechen und Abstechen

Grooving and Parting Off



Klemmhalter

Toolholder

226

mit Schraubklemmung
with screwed clamping

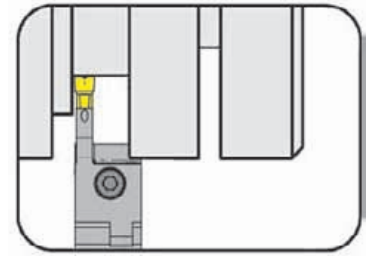

Stechtiefe bis Stechbreite	Depth of groove up to Width of groove	25 mm 3-5 mm
-------------------------------	--	-----------------

für Wendeschneidplatte
for Indexable insert

Typ S229
Type 229
N229

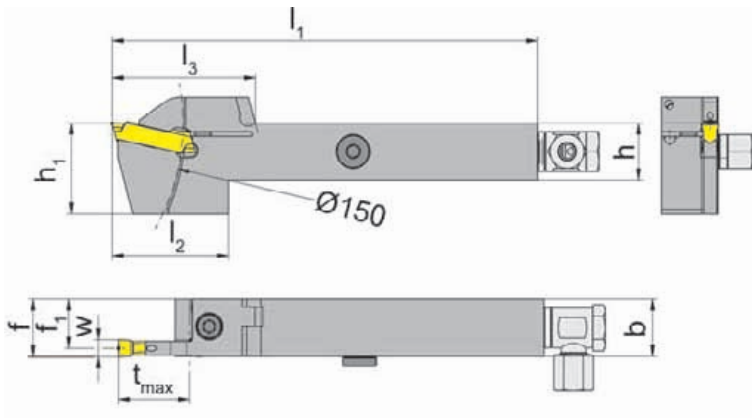

R = rechts wie gezeichnet
R = right hand version shown

L = links spiegelbildlich
L = left hand version

mit innerer
Kühlmittelezufuhr
with through coolant supply

Bestellnummer Part number	h	b	l ₁	l ₂	l ₃	h ₁	f ₁	f	t _{max}	Größe Size
R/L226.2020.0.03.IK	20	20	150	41	50,5	32	18,55	f ₁ +w/2	25	03
R/L226.2525.0.03.IK	25	25	150	39	50,5	32	23,55	f ₁ +w/2	25	03
R/L226.2020.0.04.IK	20	20	150	41	50,5	32	17,70	f ₁ +w/2	25	04
R/L226.2525.0.04.IK	25	25	150	39	50,5	32	22,70	f ₁ +w/2	25	04
R/L226.2020.0.05.IK	20	20	150	41	50,5	32	17,20	f ₁ +w/2	25	05
R/L226.2525.0.05.IK	25	25	150	39	50,5	32	22,20	f ₁ +w/2	25	05

Ausführung R oder L angeben
State R or L version

w siehe WSP
w see indexable inserts

Abmessungen in mm
Dimensions in mm

Weitere Abmessungen auf Anfrage
Further sizes upon request

Das Anzugsdrehmoment der Schrauben finden Sie in den Technischen Hinweisen.
For torque specification of the screw, please see Technical Instructions.

Ersatzteile

Spare Parts

Klemmhalter Toolholder	Dichtstopfen Sealing plug	Kühlmittelanschluss Coolant supply	Spannschraube Screw	TORX PLUS®-Schlüssel TORX PLUS® Wrench
R/L226...	004.00.26	004.00.16	6.23T25P	T25PQ

Einstecken (außen)

Grooving (external)



Klemmhalter

Toolholder

226

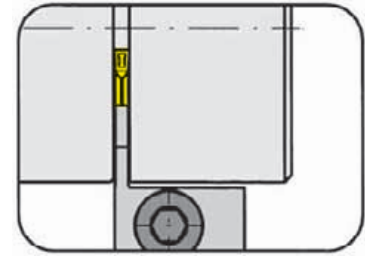

Stechtiefe bis Spannbereich	Depth of groove up to Clamping range	25 mm 6,1-8 mm
--------------------------------	---	-------------------

für Wendeschneidplatte
for Indexable insert

Typ 229
Type S229
N229

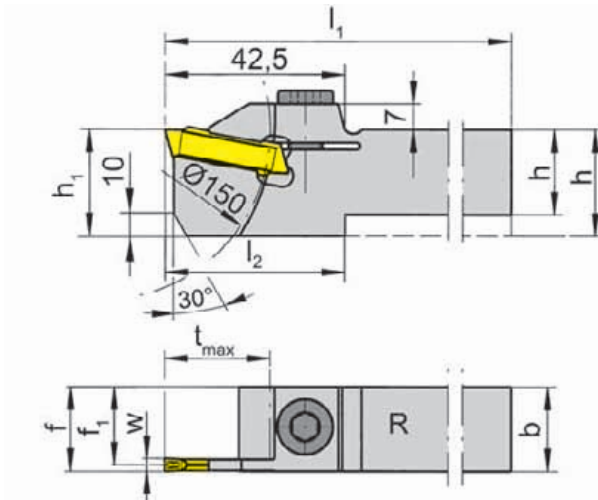

R = rechts wie gezeichnet
R = right hand version shown

L = links spiegelbildlich
L = left hand version

Bestellnummer Part number	h	b	l ₁	l ₂	h ₁	f ₁	f	t _{max}	Größe Size	Spannbereich Clamping range
R/L226.2525.07	25	25	150	42,5	32	21,2	f ₁ +w/2	25	07	6,1-8,0
R/L226.3225.07	32	25	170	-	32	21,2	f ₁ +w/2	25	07	6,1-8,0
R/L226.2525.08	25	25	150	42,5	32	20,2	f ₁ +w/2	25	08	7,6-8,0
R/L226.3225.08	32	25	170	-	32	21,2	f ₁ +w/2	25	08	7,6-8,0

Ausführung R oder L angeben
State R or L version

w siehe WSP
w see indexable inserts

Abmessungen in mm
Dimensions in mm

Weitere Abmessungen auf Anfrage
Further sizes upon request

Das Anzugsdrehmoment der Schrauben finden Sie in den Technischen Hinweisen.
For torque specification of the screw, please see Technical Instructions.

Ersatzteile

Spare Parts

Klemmhalter Toolholder	Spannschraube Screw	Inbus-Schlüssel Wrench
R/L226...	218.3	SW6,0 DIN911



Einstecken (außen)

Grooving (external)



Klemmhalter

Toolholder

226

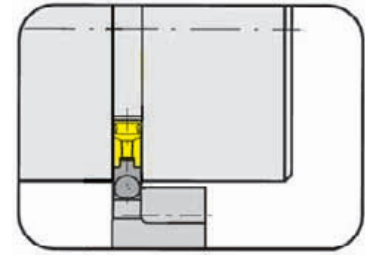

Stechtiefe bis
Spannbereich

Depth of groove up to
Clamping range

25 mm
8,1-10,4 mm

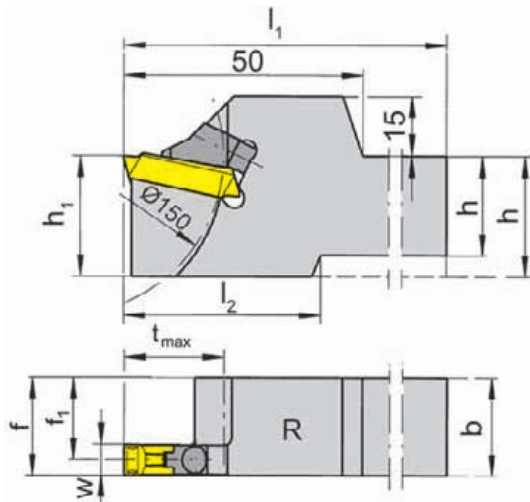

für Wendeschneidplatte
for Indexable insert

Typ S229
Type 229
N229

R = rechts wie gezeichnet
R = right hand version shown

L = links spiegelbildlich
L = left hand version

Bestellnummer Part number	h	b	l ₁	l ₂	h ₁	f ₁	f	t _{max}	Größe Size	Spannbereich Clamping range
R/L226.2525.09	25	25	150	42,5	32	20,2	f ₁ +w/2	25	09	8,1-10,4
R/L226.3225.09	32	25	170	-	32	20,2	f ₁ +w/2	25	09	8,1-10,4

Ausführung R oder L angeben
State R or L version

w siehe WSP
w see indexable inserts

Abmessungen in mm
Dimensions in mm

Weitere Abmessungen auf Anfrage
Further sizes upon request

Das Anzugsdrehmoment der Schrauben finden Sie in den Technischen Hinweisen.
For torque specification of the screw, please see Technical Instructions.

Ersatzteile

Spare Parts

Klemmhalter Toolholder	Spannelement Clamping element	TORX PLUS®-Schlüssel TORX PLUS® Wrench
R/L226...	020.1008.0041	T15PQ

Einstecken und Längsdrehen (außen)

Grooving and Side Turning (external)



Klemmhalter

Toolholder

219

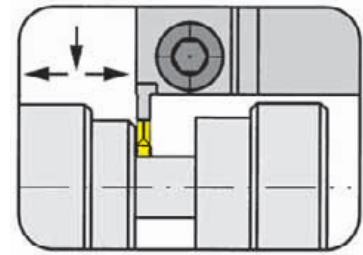

Stechtiefe bis Spannbereich	Depth of groove up to Clamping range	15 mm 3-8 mm
--------------------------------	---	-----------------

für Wendeschneidplatte
for Indexable insert

Typ S229
Type 229
N229

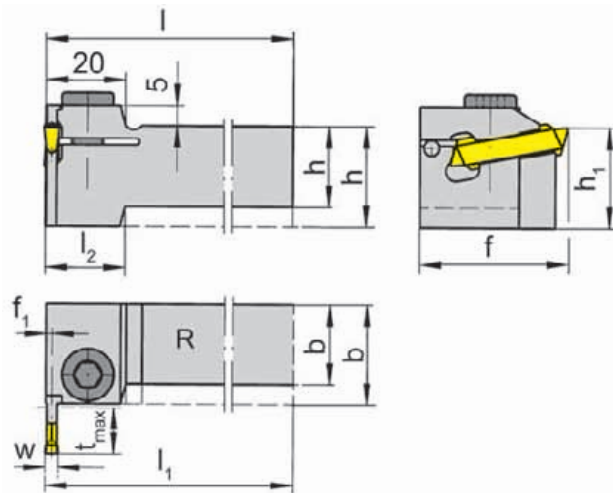

R = rechts wie gezeichnet
R = right hand version shown

L = links spiegelbildlich
L = left hand version

Bestellnummer Part number	h	b	l	l_1	l_2	h_1	f	f_1	t_{max}	Größe Size	Spannbereich Clamping range
R/L219.2020.03	20	20	150	$l-f_1+w/2$	20	25	37	1,45	11	03	3,0-4,0
R/L219.2525.03	25	25	150	$l-f_1+w/2$	-	25	37	1,45	11	03	3,0-4,0
R/L219.2020.04	20	20	150	$l-f_1+w/2$	20	25	37	2,30	11	04	4,0-5,0
R/L219.2525.04	25	25	150	$l-f_1+w/2$	-	25	37	2,30	11	04	4,0-5,0
R/L219.2020.05	20	20	150	$l-f_1+w/2$	23	25	45	2,80	15	05	5,1-6,0
R/L219.2525.05	25	25	150	$l-f_1+w/2$	-	25	45	2,80	15	05	5,1-6,0
R/L219.2020.07	20	20	150	$l-f_1+w/2$	23	25	45	3,80	15	07	6,1-8,0
R/L219.2525.07	25	25	150	$l-f_1+w/2$	-	25	45	3,80	15	07	6,1-8,0

Ausführung R oder L angeben
State R or L version

w siehe WSP
w see indexable inserts

Abmessungen in mm
Dimensions in mm

Weitere Abmessungen auf Anfrage
Further sizes upon request

Das Anzugsdrehmoment der Schrauben finden Sie in den Technischen Hinweisen.
For torque specification of the screw, please see Technical Instructions.

Ersatzteile

Spare Parts

Klemmhalter Toolholder	Spannschraube Screw	Inbus-Schlüssel Wrench
R/L219...	218.3	SW6,0 DIN911



Einstechen und Längsdrehen (außen)

Grooving and Side Turning (external)



Klemmhalter

Toolholder

219

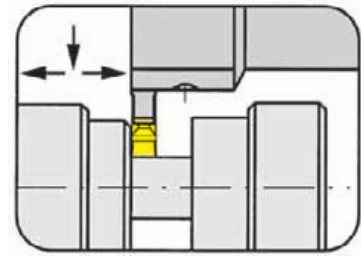

Stechtiefe bis Stechbreite	Depth of groove up to Width of groove	15 mm 8,1-10,4 mm
-------------------------------	--	----------------------

für Wendeschneidplatte
for Indexable insert

Typ S229
Type 229
N229

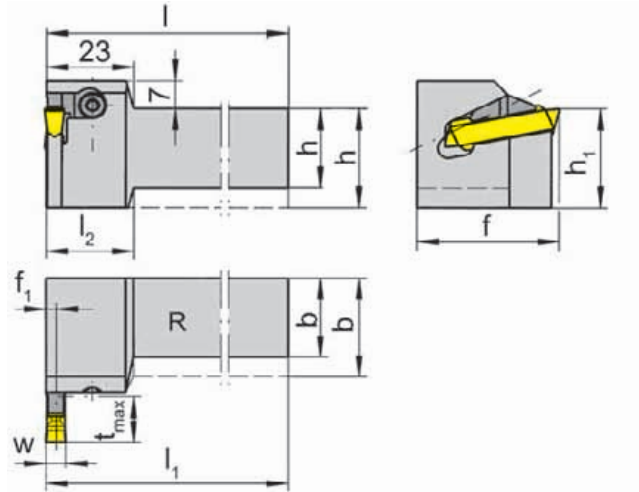

R = rechts wie gezeichnet
R = right hand version shown

L = links spiegelbildlich
L = left hand version

Bestellnummer Part number	h	b	l	l_1	l_2	h_1	f	f_1	t_{max}	Größe Size	Spannbereich Clamping range
R/L219.2020.09	20	20	150	$l-f_1+w/2$	23	25	45	4,8	15	09	8,1-10,4
R/L219.2525.09	25	25	150	$l-f_1+w/2$	-	25	45	4,8	15	09	8,1-10,4

Ausführung R oder L angeben
State R or L version

w siehe WSP
w see indexable inserts

Abmessungen in mm
Dimensions in mm

Weitere Abmessungen auf Anfrage
Further sizes upon request

Hinweis:

Bitte beachten Sie die Zuordnung der Spannelemente.

Note:

Please note type of clamp.

Das Anzugsdrehmoment der Schrauben finden Sie in den Technischen Hinweisen.

For torque specification of the screw, please see Technical Instructions.

Ersatzteile

Spare Parts

Klemmhalter Toolholder	Spannelement Clamping element	TORX PLUS®-Schlüssel TORX PLUS® Wrench
R/L219...	R218.9.32	T15PQ
R219....	L218.9.32	T15PQ

Eckenfreistechen (außen)

Grooving Corner Reliefs (external)



Klemmhalter

Toolholder

225

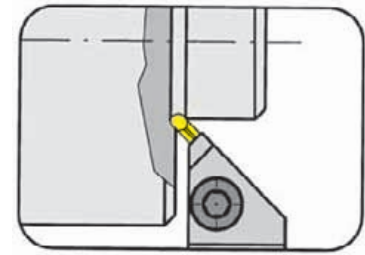

Schneidbreite	Width of groove	3-6 mm
---------------	-----------------	--------

für Wendeschneidplatte
for Indexable insert

Typ S229
Type 229
N229

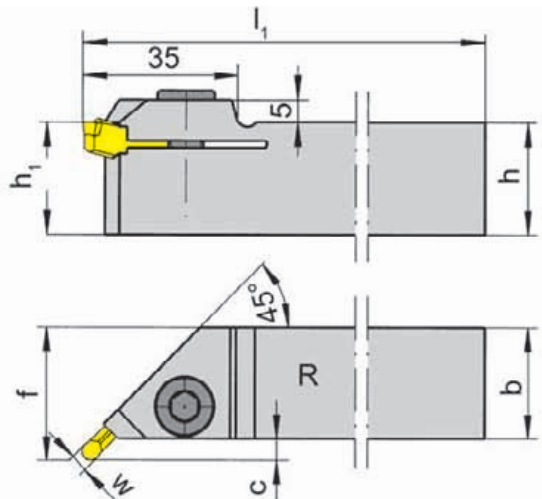

R = rechts wie gezeichnet
R = right hand version shown

L = links spiegelbildlich
L = left hand version

Bestellnummer Part number	h	b	l ₁	h ₁	f	c	D _{min}	Schneidbreite Width of groove
R/L225.2525.04	25	25	150	25	30,0	5,0	50	3,0-5,0
R/L225.2525.05	25	25	150	25	30,5	5,5	50	5,1-6,0

Ausführung R oder L angeben
State R or L version

w siehe WSP
w see indexable inserts

Abmessungen in mm
Dimensions in mm

Weitere Abmessungen auf Anfrage
Further sizes upon request

Das Anzugsdrehmoment der Schrauben finden Sie in den Technischen Hinweisen.
For torque specification of the screw, please see Technical Instructions.

Korrektur-Faktoren Δl_1 , Δc und Δf im Verhältnis zum Radius r
Revision factor Δl_1 , Δc and Δf in relation to radius r

r	Δl_1	Δc	Δf
2,5 - 3,0	0,000	0,000	0,000
2,0	-0,147	-0,147	-0,147
1,5	-0,293	-0,293	-0,293

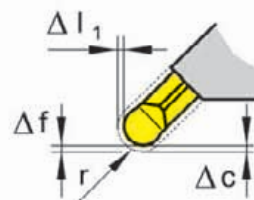

Ersatzteile

Spare Parts

Klemmhalter Toolholder	Spannschraube Screw	Inbus-Schlüssel Wrench
R/L225...	218.3	SW6,0 DIN911

Einstecken und Längsdrehen (innen)

Grooving and Side Turning (internal)



Klemmhalter

Toolholder

213

Kurzausführung
Short style

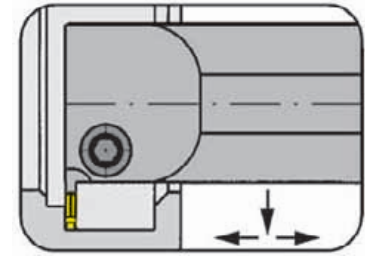

Bohrungs-Ø ab Stechtiefe bis Spannbereich	Bore Ø from Depth of groove up to Clamping range	46 mm 11,5 mm 3-6 mm
---	--	----------------------------

für Wendeschneidplatte
for Indexable insert

Typ S229
Type 229
N229

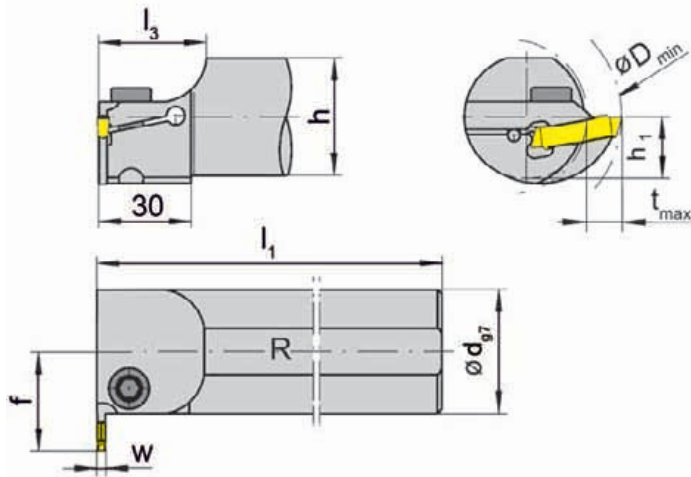

R = rechts wie gezeichnet
R = right hand version shown

L = links spiegelbildlich
L = left hand version

Bestellnummer Part number	d	l ₁	l ₃	h	h ₁	f	t _{max}	D _{min}	Größe Size	Spannbereich Clamping range
R/L213.0032.0.03	32	150	35,0	30	15	28	11,5	46	03	3,0-4,0
R/L213.0040.0.03	40	180	39,4	38	19	32	11,5	54	03	3,0-4,0
R/L213.0032.0.04	32	150	35,0	30	15	28	11,5	46	04	4,0-5,0
R/L213.0040.0.04	40	180	39,4	38	19	32	11,5	54	04	4,0-5,0
R/L213.0032.0.05	32	150	35,0	30	15	28	11,5	46	05	5,1-6,0
R/L213.0040.0.05	40	180	39,4	38	19	32	11,5	54	05	5,1-6,0

Ausführung R oder L angeben
State R or L version

w siehe WSP
w see indexable inserts

Abmessungen in mm
Dimensions in mm

Weitere Abmessungen auf Anfrage
Further sizes upon request

Das Anzugsdrehmoment der Schrauben finden Sie in den Technischen Hinweisen.
For torque specification of the screw, please see Technical Instructions.

Ersatzteile

Spare Parts

Klemmhalter Toolholder	Spannschraube Screw	Inbus-Schlüssel Wrench
R/L213...	218.3	SW6,0 DIN911

Einstechen und Längsdrehen (innen)

Grooving and Side Turning (internal)



Klemmhalter

Toolholder

213

Kurzausführung
Short style

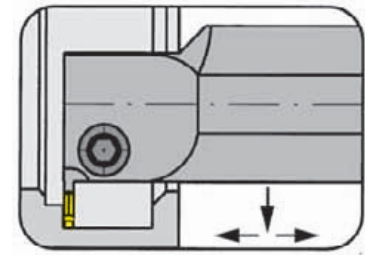

Bohrungs-Ø ab	Bore Ø from	38 mm
Stechtiefe bis	Depth of groove up to	15 mm
Spannbereich	Clamping range	3-8 mm

für Wendeschneidplatte
for Indexable insert

Typ S229
Type 229
N229

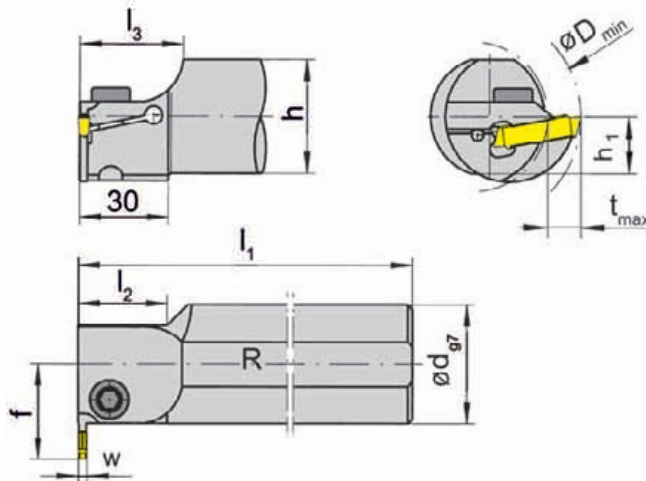

R = rechts wie gezeichnet
R = right hand version shown

L = links spiegelbildlich
L = left hand version

Bestellnummer Part number	d	l ₁	l ₂	l ₃	h	h ₁	f	t _{max}	D _{min}	Größe Size	Spannbereich Clamping range
R/L213.0025.03	25	150	-	31,8	23	11,5	24,5	7,5	38	03	3,0-4,0
R/L213.0032.03	32	150	30	35,0	30	15,0	28,0	7,5	38	03	3,0-4,0
R/L213.0040.03	40	180	30	37,4	38	19,0	32,0	11,5	50	03	3,0-4,0
R/L213.0050.03	50	200	30	39,1	47	23,5	40,5	15,0	60	03	3,0-4,0
R/L213.0025.04	25	150	-	31,8	23	11,5	24,5	7,5	38	04	4,0-5,0
R/L213.0032.04	32	150	30	35,0	30	15,0	28,0	7,5	38	04	4,0-5,0
R/L213.0040.04	40	180	30	37,4	38	19,0	32,0	11,5	50	04	4,0-5,0
R/L213.0050.04	50	200	30	39,1	47	23,5	40,5	15,0	60	04	4,0-5,0
R/L213.0032.05	32	150	-	35,0	30	15,0	28,0	11,5	46	05	5,1-6,0
R/L213.0040.05	40	180	30	35,0	38	19,0	32,0	11,5	50	05	5,1-6,0
R/L213.0050.05	50	200	30	40,0	47	23,5	40,5	15,0	60	05	5,1-6,0
R/L213.0040.07	40	180	30	35,0	38	19,0	32,0	11,5	50	07	6,1-8,0
R/L213.0050.07	50	200	30	40,0	47	23,5	40,5	15,0	60	07	6,1-8,0

Ausführung R oder L angeben
State R or L version

w siehe WSP
w see indexable inserts

Abmessungen in mm
Dimensions in mm

Weitere Abmessungen auf Anfrage
Further sizes upon request

Betrifft Halter mit Schaft-Ø 25 oder 32 mm:

Die volle Stechtiefe $t_{max} = 11,5$ mm wird ab $D_{min} = 46$ mm erreicht

Note toolholder with shank-Ø 25 or 32 mm

The full depth of cut $t_{max} = 11,5$ mm will be reached from $D_{min} = 46$ mm

Das Anzugsdrehmoment der Schrauben finden Sie in den Technischen Hinweisen.
For torque specification of the screw, please see Technical Instructions.

Ersatzteile

Spare Parts

Klemmhalter Toolholder	Spannschraube Screw	Inbus-Schlüssel Wrench
R/L213...	218.3	SW6,0 DIN911

H

Einstechen und Längsdrehen (innen)

Grooving and Side Turning (internal)



Klemmhalter

Toolholder

213

Kurzausführung
Short style

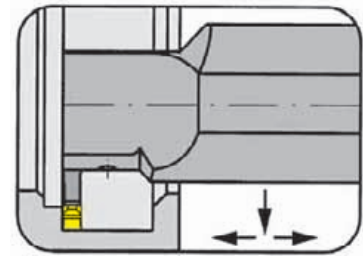

Bohrungs-Ø ab	Bore Ø from	50 mm
Stechtiefe bis	Depth of groove up to	15 mm
Spannbereich	Clamping range	8,1-10,4 mm

für Wendeschneidplatte
for Indexable insert

Typ S229
Type 229
N229

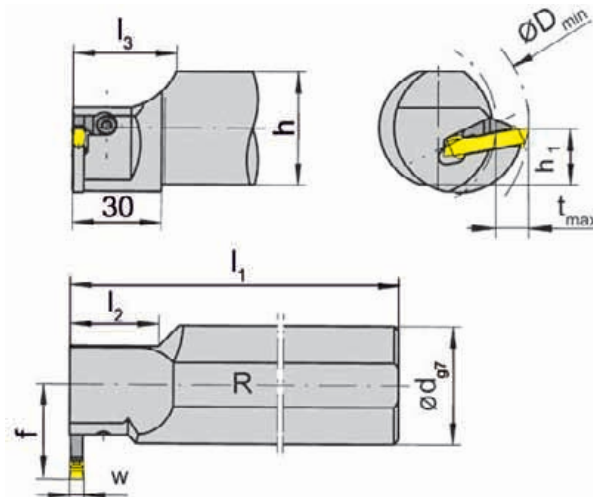

R = rechts wie gezeichnet
R = right hand version shown

L = links spiegelbildlich
L = left hand version

Bestellnummer Part number	d	l ₁	l ₂	l ₃	h	h ₁	f	t _{max}	D _{min}	Größe Size	Spannbereich Clamping range
R/L213.0040.09	40	180	30	35	38	19,0	32,0	11,5	50	09	8,1-10,4
R/L213.0050.09	50	200	30	40	47	23,5	40,5	15,0	60	09	8,1-10,4

Ausführung R oder L angeben
State R or L version

w siehe WSP
w see indexable inserts

Abmessungen in mm
Dimensions in mm

Weitere Abmessungen auf Anfrage
Further sizes upon request

Hinweis:

Bitte beachten Sie die Zuordnung der Spannelemente.

Note:

Please note type of clamp.

Das Anzugsdrehmoment der Schrauben finden Sie in den Technischen Hinweisen.

For torque specification of the screw, please see Technical Instructions.

Ersatzteile

Spare Parts

Klemmhalter Toolholder	Spannelement Clamping element	TORX PLUS®-Schlüssel TORX PLUS® Wrench
R/L213.0...	R218.9	T15PQ
R213.0...	L218.9	T15PQ

Einstecken und Längsdrehen (innen)

Grooving and Side Turning (internal)



Klemmhalter

Toolholder

213

Kurzausführung
Short style

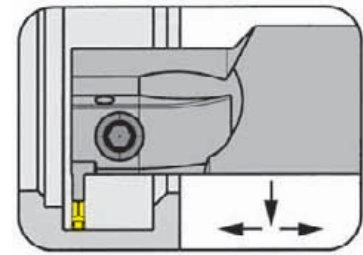

Bohrungs-Ø ab Stechtiefe bis Spannbereich	Bore Ø from Depth of groove up to Clamping range	38 mm 11,5 mm 3-5 mm
---	--	----------------------------

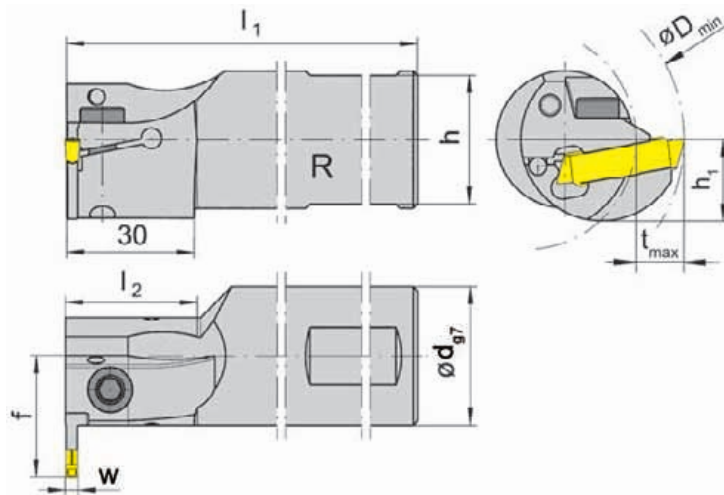

für Wendeschneidplatte
for Indexable insert

Typ S229
Type 229
N229

R = rechts wie gezeichnet
R = right hand version shown

L = links spiegelbildlich
L = left hand version

mit innerer
Kühlmittelzufuhr
with through coolant supply

Bestellnummer Part number	d	l ₁	l ₂	h	h ₁	f	t _{max}	D _{min}	Größe Size	Spannbereich Clamping range
R/L213.0025.03IK	25	150	-	23	11,5	24,5	7,5	38	03	3-4
R/L213.0025.04IK	25	150	-	23	11,5	24,5	7,5	38	04	4-5
R/L213.0032.03IK	32	150	30	30	15,0	28,0	7,5	38	03	3-4
R/L213.0032.04IK	32	150	30	30	15,0	28,0	7,5	38	04	4-5
R/L213.0040.03IK	40	180	30	38	19,0	32,0	11,5	50	03	3-4

Ausführung R oder L angeben
State R or L version

w siehe WSP
w see indexable inserts

Abmessungen in mm
Dimensions in mm

Betrifft Halter mit Schaft-Ø 25 oder 32 mm:

Die volle Stechtiefe t_{max} = 11,5 mm wird ab D_{min} 46 mm erreicht

Note toolholder with shank-Ø 25 or 32 mm

The full depth of cut t_{max} = 11,5 mm will be reached from D_{min} 46 mm

Weitere Abmessungen auf Anfrage

Further sizes upon request

Das Anzugsdrehmoment der Schrauben finden Sie in den Technischen Hinweisen.

For torque specification of the screw, please see Technical Instructions.

Ersatzteile

Spare Parts

Klemmhalter Toolholder	Inbus-Schlüssel Wrench
R/L213...	SW5,0 DIN911



Einstecken und Längsdrehen (innen)

Grooving and Side Turning (internal)



Klemmhalter

Toolholder

213

Kurzausführung
Short style

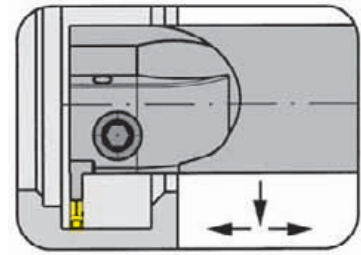

Bohrungs-Ø ab Stechtiefe bis Spannbereich	Bore Ø from Depth of groove up to Clamping range	46 mm 11,5 mm 3-6 mm
---	--	----------------------------

für Wendeschneidplatte
for Indexable insert

Typ S229
Type 229
N229

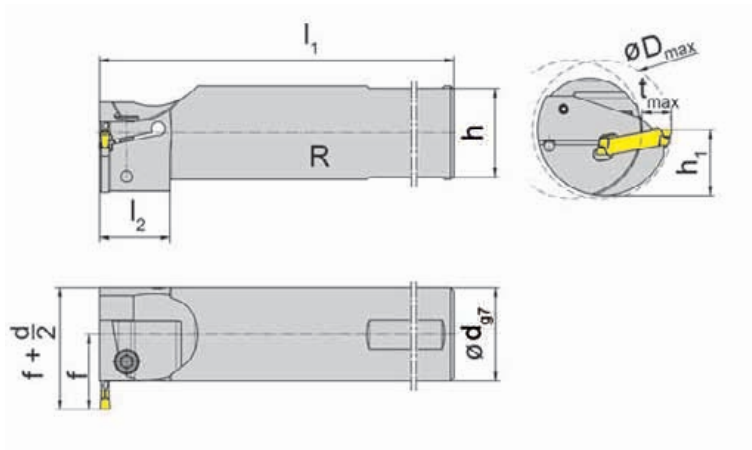

R = rechts wie gezeichnet
R = right hand version shown

L = links spiegelbildlich
L = left hand version

mit innerer
Kühlmittelzufuhr
with through coolant supply

Bestellnummer Part number	d	l ₁	l ₂	h	h ₁	f	t _{max}	D _{min}	Größe Size	Spannbereich Clamping range
R/L213.0032.0.03IK	32	150	30	30	15	28	11,5	46	03	3,0-4,0
R/L213.0032.0.04IK	32	150	30	30	15	28	11,5	46	04	4,0-5,0
R/L213.0040.0.04IK	40	180	30	38	19	32	11,5	54	04	4,0-5,0
R/L213.0040.0.05IK	40	180	30	38	19	32	11,5	54	05	5,1-6,0

Ausführung R oder L angeben
State R or L version

w siehe WSP
w see indexable inserts

Abmessungen in mm
Dimensions in mm

Weitere Abmessungen auf Anfrage
Further sizes upon request

Das Anzugsdrehmoment der Schrauben finden Sie in den Technischen Hinweisen.
For torque specification of the screw, please see Technical Instructions.

Ersatzteile

Spare Parts

Klemmhalter Toolholder	Inbus-Schlüssel Wrench
R/L213...	SW5,0 DIN911

Einstechen und Längsdrehen (innen)

Grooving and Side Turning (internal)



Klemmhalter

Toolholder

214

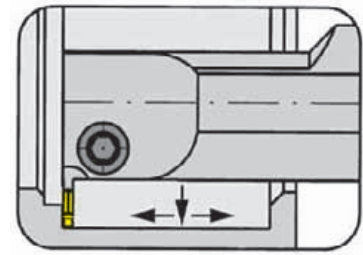

Bohrungs-Ø ab	Bore Ø from	38 mm
Stechtiefe bis	Depth of groove up to	15 mm
Spannbereich	Clamping range	3-8 mm

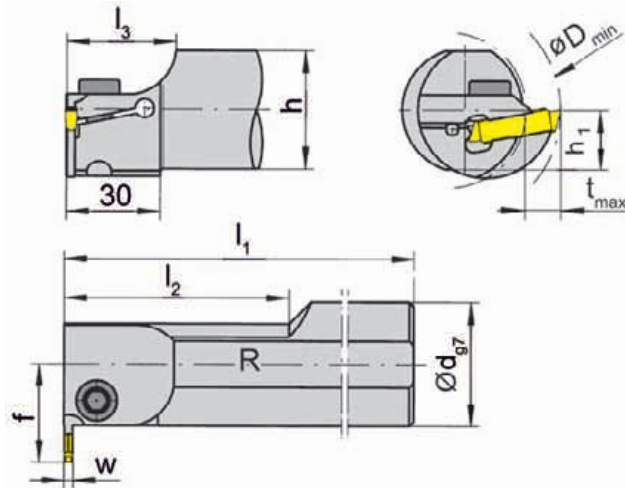

für Wendeschneidplatte
for Indexable insert

Typ S229
Type 229
N229

R = rechts wie gezeichnet
R = right hand version shown

L = links spiegelbildlich
L = left hand version

Bestellnummer Part number	d	l ₁	l ₂	l ₃	h	h ₁	f	t _{max}	D _{min}	Größe Size	Spannbereich Clamping range
R/L214.0032.03	32	200	70	35	30	15,0	28,0	7,5	38	03	3,0-4,0
R/L214.0040.03	40	250	80	35	38	19,0	32,0	11,5	50	03	3,0-4,0
R/L214.0050.03	50	250	100	40	47	23,5	40,5	15,0	60	03	3,0-4,0
R/L214.0032.04	32	200	70	35	30	15,0	28,0	7,5	38	04	4,0-5,0
R/L214.0040.04	40	250	80	35	38	19,0	32,0	11,5	50	04	4,0-5,0
R/L214.0050.04	50	250	100	40	47	23,5	40,5	15,0	60	04	4,0-5,0
R/L214.0032.05	32	200	-	35	30	15,0	28,0	11,5	46	05	5,1-6,0
R/L214.0040.05	40	250	80	35	38	19,0	32,0	11,5	50	05	5,1-6,0
R/L214.0050.05	50	250	100	40	47	23,5	40,5	15,0	60	05	5,1-6,0
R/L214.0040.07	40	250	80	35	38	19,0	32,0	11,5	50	07	6,1-8,0
R/L214.0050.07	50	250	100	40	47	23,5	40,5	15,0	60	07	6,1-8,0

Ausführung R oder L angeben
State R or L version

w siehe WSP
w see indexable inserts

Abmessungen in mm
Dimensions in mm

Betrifft Halter mit Schaft-Ø 25 oder 32 mm:

Die volle Stechtiefe t_{max} = 11,5 mm wird ab D_{min} 46 mm erreicht

Note toolholder with shank-Ø 25 or 32 mm

The full depth of cut t_{max} = 11,5 mm will be reached from D_{min} 46 mm

Weitere Abmessungen oder mit innerer Kühlmittelzufuhr auf Anfrage.

Further shank sizes or with through coolant supply upon request.

Das Anzugsdrehmoment der Schrauben finden Sie in den Technischen Hinweisen.

For torque specification of the screw, please see Technical Instructions.

Ersatzteile

Spare Parts

Klemmhalter Toolholder	Spannschraube Screw	Inbus-Schlüssel Wrench
R/L214...	218.3	SW6,0 DIN911

H

Einstecken und Längsdrehen (innen)

Grooving and Side Turning (internal)



Klemmhalter

Toolholder

214

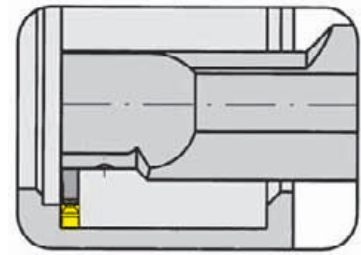

Bohrungs-Ø ab	Bore Ø from	50 mm
Stechtiefe bis	Depth of groove up to	15 mm
Spannbereich	Clamping range	8,1-10,4 mm

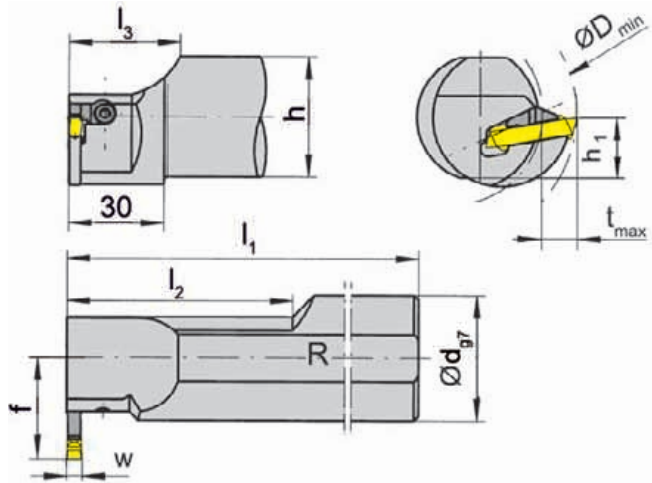

für Wendeschneidplatte
for Indexable insert

Typ S229
Type 229
N229

R = rechts wie gezeichnet
R = right hand version shown

L = links spiegelbildlich
L = left hand version

Bestellnummer Part number	d	l ₁	l ₂	l ₃	h	h ₁	f	t _{max}	D _{min}	Größe Size	Spannbereich Clamping range
R/L214.0040.09	40	250	80	35	38	19,0	32,0	11,5	50	09	8,1-10,4
R/L214.0050.09	50	250	100	40	47	23,5	40,5	15,0	60	09	8,1-10,4

Ausführung R oder L angeben
State R or L version

w siehe WSP
w see indexable inserts

Abmessungen in mm
Dimensions in mm

Weitere Abmessungen oder mit innerer Kühlmittelzufuhr auf Anfrage.
Further shank sizes or with through coolant supply upon request.

Hinweis:

Bitte beachten Sie die Zuordnung der Spannelemente.

Note:

Please note type of clamp.

Das Anzugsdrehmoment der Schrauben finden Sie in den Technischen Hinweisen.

For torque specification of the screw, please see Technical Instructions.

Ersatzteile

Spare Parts

Klemmhalter Toolholder	Spannelement Clamping element	TORX PLUS®-Schlüssel TORX PLUS® Wrench
L214.0...	R218.9	T15PQ
R214.0...	L218.9	T15PQ

Einstecken und Längsdrehen (innen)

Grooving and Side Turning (internal)



Grundhalter

Basic toolholder

B229

ohne Kasette
without cassette

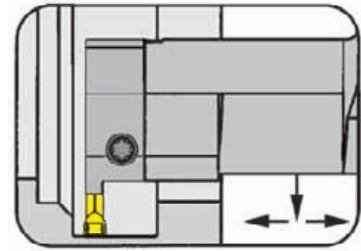

Bohrungs-Ø	Bore Ø	50 / 60 mm
Stechtiefe bis	Depth of groove up to	12 / 15 mm
Stechbreite	Width of groove	3-6 mm

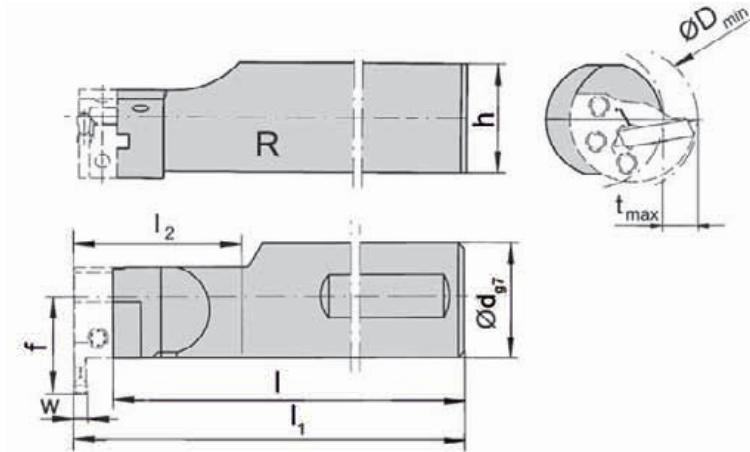

R = rechts wie gezeichnet
R = right hand version shown

L = links spiegelbildlich
L = left hand version

für Kassetten
for Cassette

Typ BK229
Type

mit innerer
Kühlmittelzufuhr
with through coolant supply

Bestellnummer Part number	d	l	l ₁	l ₂	h	f
R/LB229.0040.1.K2	40	172,5	187	30	38	35,5
R/LB229.0040.2.K2	40	185,5	200	60	38	35,5

Ausführung R oder L angeben
State R or L version

w siehe WSP
w see indexable inserts

Abmessungen in mm
Dimensions in mm

Weitere Abmessungen auf Anfrage
Further sizes upon request

Hinweis:

Abmessungen für D_{min} , t_{max} siehe Kassetten

Note:

Dimensions for D_{min} , t_{max} see cassettes

Ersatzteile

Spare Parts

Grundhalter Basic toolholder	Spannschraube Screw	TORX PLUS®-Schlüssel TORX PLUS® Wrench
R/LB229...	030.0518T20P	T20PQ

Einstecken und Längsdrehen (innen)

Grooving and Side Turning (internal)



Kassette

Cassette

BK229

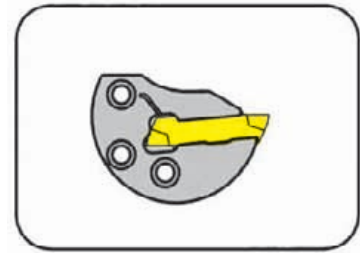

Bohrungs-Ø ab Stechtiefe Spannbereich	Bore Ø from Depth of groove Clamping range	50 / 60 mm 12 / 15 mm 3-6 mm
---	--	------------------------------------

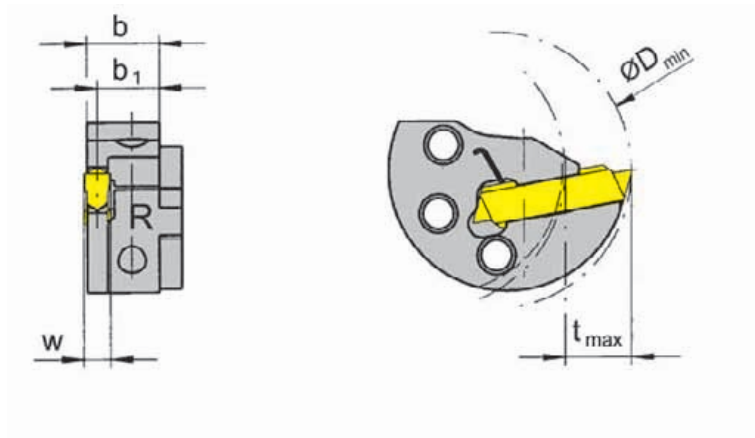

für Wendeschneidplatte
for Indexable insert

Typ S229
Type 229
N229

Stechtiefe in Abhängigkeit des Bohrungs-Ø
Depth of groove in relation to bore Ø

D _{min}	t _{max}
50	12
60	15

R = rechts wie gezeichnet
R = right hand version shown

L = Linksausführung
L = left hand version

Bestellnummer Part number	b ₁	b	D _{min}	t _{max}	Größe Size	Spannbereich Clamping range
R/LBK229.0050.03	13,0	14,25	50/60	12/15	03	3,00-4,00
R/LBK229.0050.04	12,5	14,20	50/60	12/15	04	4,00-5,09
R/LBK229.0050.05	11,5	13,85	50/60	12/15	05	5,10-6,00

Ausführung R oder L angeben
State R or L version

w siehe WSP
w see indexable inserts

Abmessungen in mm
Dimensions in mm

Weitere Abmessungen auf Anfrage
Further sizes upon request

Rechte Kassetten in rechten und linke Kassetten in linken Grundhaltern verwenden.
Rechte Kassetten in rechten und linke Kassetten in linken Grundhaltern verwenden.

Bestellhinweis:

Befestigungsschrauben der Kassetten gehören zum Lieferumfang des Grundhalters.

Ordering note:

The fastening screw is combined with the basic toolholder - no separate order required.

Das Anzugsdrehmoment der Schrauben finden Sie in den Technischen Hinweisen.

For torque specification of the screw, please see Technical Instructions.

Ersatzteile

Spare Parts

Kassette Cassette	Spannschraube Screw	TORX PLUS®-Schlüssel TORX PLUS® Wrench
R/LBK229...	5.13T20EP	T20PQ

Einstecken (innen)

Grooving (internal)



Kurzklemmhalter

Cartridge

257

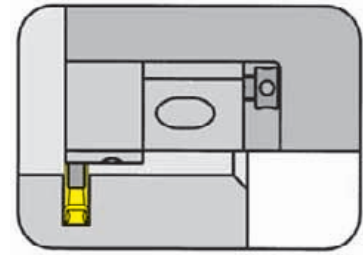

Bohrungs-Ø ab Stechtiefe Spannbereich	Bore Ø from Depth of groove Clamping range	80/120 mm 10/15 mm 5,1-10,4 mm
---	--	--------------------------------------

für Wendeschneidplatte
for Indexable insert

Typ S229
Type 229
N229

Stechtiefe in Abhängigkeit des Bohrungs-Ø
Depth of groove in relation to bore Ø

D _{min}	t _{max}
80	10
120	15

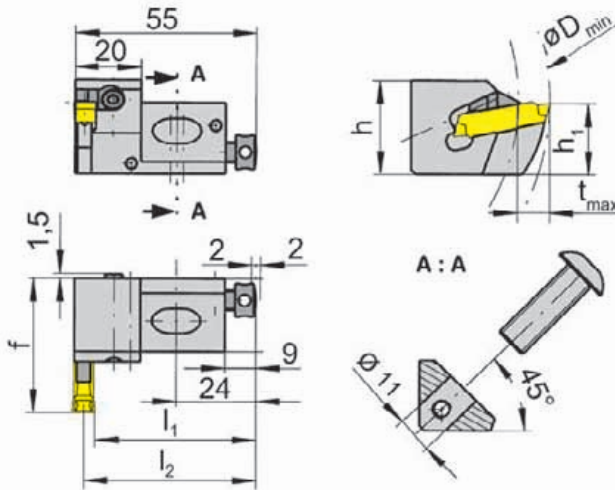

R = rechts wie gezeichnet
R = right hand version shown

L = links spiegelbildlich
L = left hand version

Bestellnummer Part number	h	h ₁	f	l ₂	l ₁	Größe Size	Spannbereich Clamping range
R/L257.2222.05	29	22	42	52,2	l ₂ -w/2	05	5,1-6,0
R/L257.2222.07	29	22	42	51,2	l ₂ -w/2	07	6,1-8,0
R/L257.2222.09	29	22	42	50,2	l ₂ -w/2	09	8,1-10,4

Ausführung R oder L angeben
State R or L version

w siehe WSP
w see indexable inserts

Abmessungen in mm
Dimensions in mm

Weitere Abmessungen auf Anfrage
Further sizes upon request

Bestellhinweis:

Bitte beachten Sie die Zuordnung der Spannelemente.

Ordering note:

Please note type of clamp.

Das Anzugsdrehmoment der Schrauben finden Sie in den Technischen Hinweisen.

For torque specification of the screw, please see Technical Instructions.

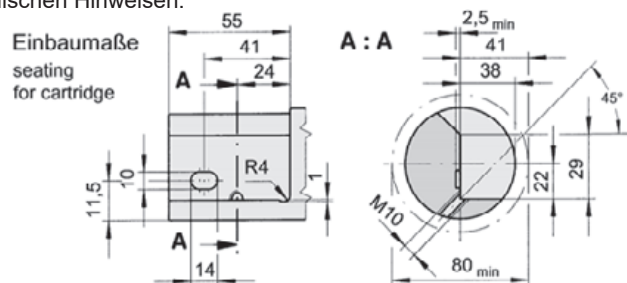

Ersatzteile

Spare Parts

Kurzklemmhalter Cartridge	Spannschraube Screw	Inbus-Schlüssel Wrench	Spannelement Clamping element	TORX PLUS®-Schlüssel TORX PLUS® Wrench
R/L257.2222.05	218.3	SW2,0 DIN911		
L257.2222.07	4.08.913		R218.5.7.32	T15PQ
R257.2222.07	4.08.913		L218.5.7.32	T15PQ
L257.2222.09	4.08.913		R218.9.32	T15PQ
R257.2222.09	4.08.913		L218.9.32	T15PQ

Einstecken (innen)

Grooving (internal)



Kassette

Cassette

050

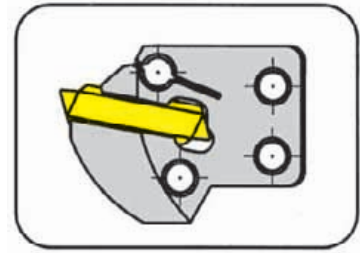

Bohrungs-Ø ab
Stechtiefe bis
Stechbreite

Bore Ø from
Depth of groove up to
Width of groove

62 mm
14 mm
3-5 mm

für Grundhalter Typ 210 mit Kassette
for basic toolholder type 210 with cassette

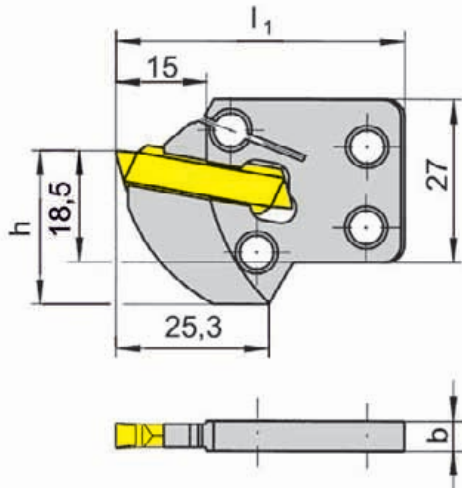

für Wendeschneidplatte
for Indexable insert

Typ S229
Type 229
N229

Stechtiefe in Abhängigkeit des Bohrungs-Ø
Depth of groove in relation to bore Ø

D _{min}	t _{max}
62	10
65	11
70	13
≥ 80	14

Bestellnummer Part number	b	l ₁	h	Größe Size	Spannbereich Clamping range
050.1827.0071	4,9	47	25,5	03	3,00-4,00
050.1827.0009	4,9	47	25,5	04	4,00-5,09

Weitere Abmessungen auf Anfrage
Further sizes upon request

Abmessungen in mm
Dimensions in mm

Das Anzugsdrehmoment der Schrauben finden Sie in den Technischen Hinweisen.
For torque specification of the screw, please see Technical Instructions.

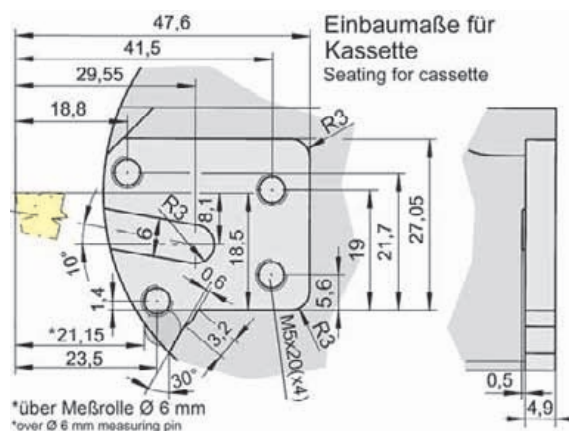

Ersatzteile

Spare Parts

Kassette Cassette	Befestigungsschraube Fixing Screw	TORX PLUS®-Schlüssel TORX PLUS® Wrench
050.1827.00...	030.0518T20P	T20PQ



Wendeschneidplatte

Indexable insert

S229...3.

präzisionsgesintert
precision sintered



Geometrie .3.

Geometry

Geometrie mit Spanformrille für alle Werkstoffe.
Geometry with chip forming for all materials.

Hauptmerkmale Characteristics

- sichere Spankontrolle (Spanrolle)
- universell einsetzbar - auch für Werkstoffe mit höherer Festigkeit
- saubere Nutflanken durch Spanformung
- Produktionssicherheit durch kontrollierten Spanablauf

Einsatzgebiete Applications

- Einstechen:
Stechtiefe bis 25 mm
- Längsdrehen:
Schnittiefe a_p bis 4 mm*
- Grooving:
Depth of groove up to 25 mm
- Side turning:
Depth of cut a_p up to 4 mm*

- excellent swarf control
- suitable for high alloy- high strength steels
- reduced swarf width gives high flank surface finish
- excellent swarf control allows production security

Vorschub f Feed rate f

- Einstechen: 0,15 bis 0,25 mm/U*
- Längsdrehen: bis 0,4 mm/U*
- Grooving: 0,15 up to 0,25 mm/rev*
- Side turning: up to 0,4 mm/rev*

* abhängig von der Plattenbreite
* dependent upon width of insert

Formwendeschneidplatten, Zwischenmaße oder andere Eckenradien sind auf Anfrage erhältlich!
Wendeschneidplatten sind in **rechten und linken** Klemmhaltern verwendbar.

Indexable inserts with profiles, intermediate sizes or other edge radii are available upon request.
Indexable inserts can be used in **right and left hand** toolholders.

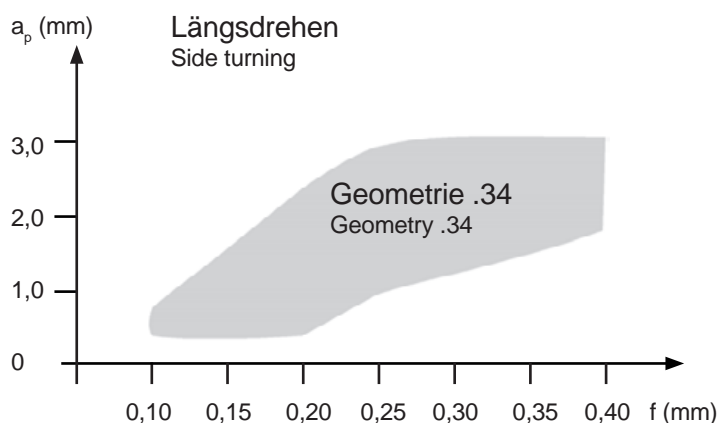

Spanbruchdiagramm S229.0500.34, Werkstoff 16MnCr5
Chip control graph S229.0500.34 material 16MnCr5

Einstechen und Längsdrehen

Grooving and Side Turning



Wendeschneidplatte

Indexable insert

S229

mit Spanformrinne
with chip former

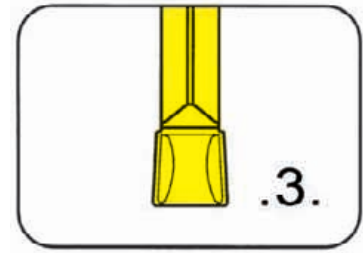

Stechtiefe bis Stechbreite	Depth of groove up to Width of groove	25 mm 3-10 mm
-------------------------------	--	------------------

präzisionsgesintert
precision sintered

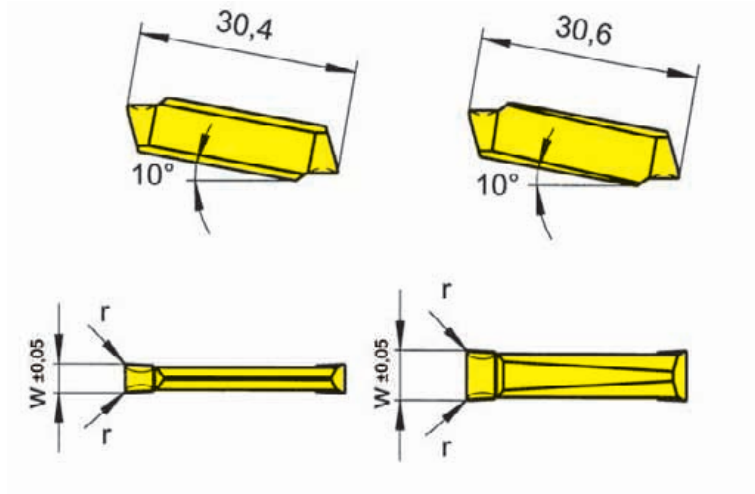

Schneidbreite 3,0 - 5,0 mm
Width 3,0 - 5,0 mm

Schneidbreite 6,0 - 10,0 mm
Width 6,0 - 10,0 mm

für Klemmhalter
for Toolholder

- Typ 210
- Type 213
- 214
- 218
- 219
- 225
- 226
- 257
- R/LA210
- R/LA226

Wechselgenauigkeit
Länge ± 0,06 mm
Indexability length ± 0,06 mm

Bestellnummer Part number	w	r	Größe Size	Material Groups													
				MG12	AL96	AS62	AS66	H54	P20	TA45	TC92	TF42	TF45	TI22	TI25	TN32	TN35
S229.0300.32	3	0,2	03	▲	▲	▲	▲	▲	▲	▲	▲	▲	▲	▲	▲	▲	▲
S229.0300.34	3	0,4	03	▲	▲	▲	▲	▲	▲	▲	▲	▲	▲	▲	▲	▲	▲
S229.0400.32	4	0,2	03/04	▲	▲	▲	▲	▲	▲	▲	▲	▲	▲	▲	▲	▲	▲
S229.0400.34	4	0,4	03/04	▲	▲	▲	▲	▲	▲	▲	▲	▲	▲	▲	▲	▲	▲
S229.0500.34	5	0,4	04	▲	▲	▲	▲	▲	▲	▲	▲	▲	▲	▲	▲	▲	▲
S229.0500.36	5	0,6	04	▲	▲	▲	▲	▲	▲	▲	▲	▲	▲	▲	▲	▲	▲
S229.0600.34	6	0,4	05	▲	▲	▲	▲	▲	▲	▲	▲	▲	▲	▲	▲	▲	▲
S229.0600.38	6	0,8	05	▲	▲	▲	▲	▲	▲	▲	▲	▲	▲	▲	▲	▲	▲
S229.0700.36	7	0,6	07	▲	▲	▲	▲	▲	▲	▲	▲	▲	▲	▲	▲	▲	▲
S229.0800.36	8	0,6	07	▲	▲	▲	▲	▲	▲	▲	▲	▲	▲	▲	▲	▲	▲
S229.0800.38	8	0,8	07	x	▲	▲	▲	▲	▲	▲	▲	▲	▲	x	▲	▲	x
S229.0800.3K	8	1,2	07	▲	▲	▲	▲	▲	▲	▲	▲	▲	▲	▲	▲	▲	▲
S229.1000.36	10	0,6	09	▲	▲	▲	▲	▲	▲	▲	▲	▲	▲	▲	▲	▲	▲
▲ ab Lager / on stock				P	o	•	•	•	•	•	•	•	•	•	•	•	•
x auf Anfrage / upon request				M	•	-	-	o	•	-	-	-	•	-	-	-	•
• empfohlen / recommended				K	•	•	-	•	-	-	-	-	-	-	-	-	-
o bedingt einsetzbar / alternative recommendation				N	•	•	-	•	-	-	-	-	-	-	-	-	-
- nicht geeignet / not suitable				S	•	-	-	o	-	-	-	-	-	-	-	-	-
unbeschichtete HM-Sorten / uncoated grades				H	-	-	-	-	-	-	-	-	-	-	-	-	-
beschichtete HM-Sorten / coated grades																	
bestückt/Cermet / brazed/Cermet																	

Abmessungen in mm
Dimensions in mm

HM-Sorten
Carbide grades

Wendeschneidplatten sind in rechten und linken Klemmhaltern verwendbar.
Indexable inserts can be used in right and left hand toolholders.



Wendeschnidplatte

Indexable insert

S229...5.

präzisionsgesintert
precision sintered



Geometrie .5.

Leichtschneidende Geometrie für Werkstoffe mittlerer Festigkeit.
Easy cutting geometry for materials with medium strength.

Hauptmerkmale Characteristics

- sichere Spankontrolle über einen weiten Vorschubsbereich
- leichtschneidend - geringe Leistungsaufnahme
- saubere Nutflanken durch Spanformung
- Produktionssicherheit durch Spanformung

Einsatzgebiete Applications

- Einstechen: Stechtiefe bis 25 mm
- Längsdrehen: Schnitttiefe a_p bis 4 mm*
- Grooving: Depth of groove up to 25 mm
- Side turning: Depth of cut a_p up to 4 mm*



- excellent swarf on a wide feed range
- easy cutting - low power requirement
- reduced swarf width gives high flank surface finish
- excellent swarf control allows production security

Vorschub f Feed rate f

- Einstechen: bis 0,45 mm/U*
- Längsdrehen: bis 0,6 mm/U*
- Grooving: up to 0,45 mm/rev*
- Side turning: up to 0,6 mm/rev*

* abhängig von der Plattenbreite
* dependent upon width of insert

Formwendeschnidplatten, Zwischenmaße oder andere Eckenradien sind auf Anfrage erhältlich!
Wendeschnidplatten sind in **rechten und linken** Klemmhaltern verwendbar.

Indexable inserts with profiles, intermediate sizes or other edge radii are available upon request.
Indexable inserts can be used in **right and left hand** toolholders.

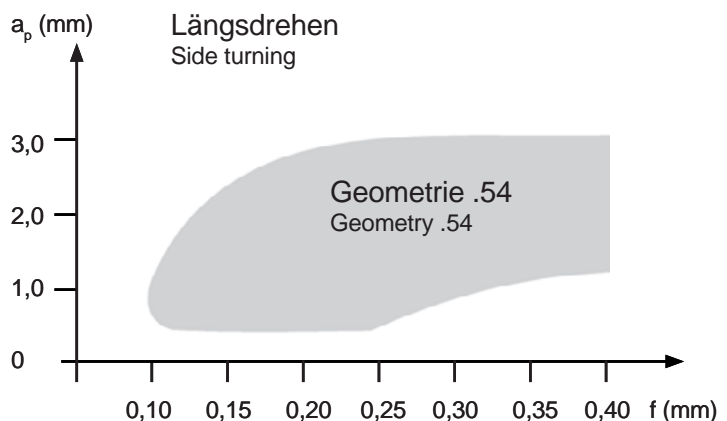

Spanbruchdiagramm S229.0500.54, Werkstoff 16MnCr5
Chip control graph S229.0500.54 material 16MnCr5

Einstechen und Längsdrehen

Grooving and Side Turning



Wendeschneidplatte

Indexable insert

S229

mit Spanformung
with chip forming

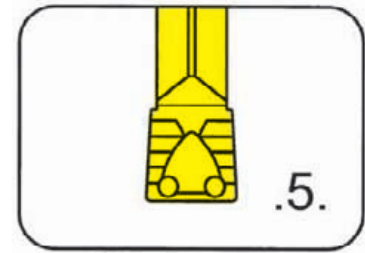

Stechtiefe bis
Stechbreite

Depth of groove up to
Width of groove

25 mm
3-10 mm

präzisionsgesintert
precision sintered

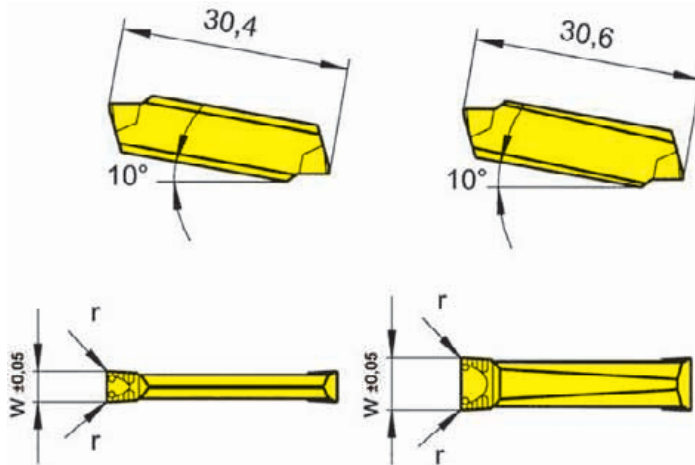

Schneidbreite 3,0 - 5,0 mm
Width 3,0 - 5,0 mm

Schneidbreite 6,0 - 10,0 mm
Width 6,0 - 10,0 mm

für Klemhalter
for Toolholder

Typ 210
Type 213
214
218
219
225
226
257
R/LA210
R/LA226

Wechselgenauigkeit
Länge ± 0,06 mm
Indexability length ± 0,06 mm

Bestellnummer Part number	w	r	Größe Size	AL96	AS62	P20	TC92	TF42	TF45	Ti22	Ti25	TN32	TN35
S229.0300.52	3	0,2	03	Δ	▲	Δ	Δ		▲	▲	▲	▲	▲
S229.0300.54	3	0,4	03	Δ	▲		Δ		▲	▲	▲	▲	▲
S229.0400.52	4	0,2	03/04	Δ	▲	Δ	▲		▲	▲	▲	▲	▲
S229.0400.54	4	0,4	03/04	Δ	▲				▲	▲	▲	▲	▲
S229.0500.54	5	0,4	04	Δ	▲	Δ	▲		▲	▲	▲	▲	▲
S229.0500.56	5	0,6	06			x	Δ			x	Δ	Δ	Δ
S229.0600.54	6	0,4	05	Δ	▲	Δ	▲		▲		▲	▲	▲
S229.0600.56	6	0,6	05	Δ		x	Δ				Δ	Δ	Δ
S229.0600.58	6	0,8	05		▲								
S229.0700.56	7	0,6	07		▲	Δ	Δ			▲		Δ	
S229.0800.56	8	0,6	07	Δ	▲	Δ	Δ			▲		▲	
S229.0800.58	8	0,8	07	Δ		Δ	Δ	Δ		▲		Δ	
S229.0800.5K	8	1,2	07	Δ		x	Δ			▲			
S229.1000.56	10	0,6	09	Δ		Δ	Δ			▲		▲	
P	•	•	•	•	•	•	•	•	•	•	•	•	•
M	-	-	-	-	-	-	-	-	•	-	•	-	•
K	•	-	-	-	-	-	-	-	•	-	•	-	•
N	•	-	-	-	-	-	-	-	•	-	•	-	•
S	-	-	-	-	-	-	-	-	•	-	•	-	•
H	-	-	-	-	-	-	-	-	-	-	-	-	-

▲ ab Lager / on stock Δ 4 Wochen / 4 weeks x auf Anfrage / upon request
 ● empfohlen / recommended
 o bedingt einsetzbar / alternative recommendation
 - nicht geeignet / not suitable
 ■ unbeschichtete HM-Sorten / uncoated grades
 ■ beschichtete HM-Sorten / coated grades
 ■ bestückt/Cermet / brazed/Cermet

Abmessungen in mm
Dimensions in mm

Wendeschneidplatten sind in rechten und linken Klemhaltern verwendbar.
Indexable inserts can be used in right and left hand toolholders.

HM-Sorten
Carbide grades



Wendeschneidplatte

Indexable insert

S229...A.

präzisionsgesintert
precision sintered



Geometrie .A.

Geometry .A.

Geometrie mit sicherem Spanbruch für Werkstoffe mittlerer Festigkeit
Geometry with excellent chip breaking for materials with medium strength

Hauptmerkmale Characteristics

- sichere Spankontrolle über einen weiten Vorschubsbereich
- kontrollierte Späne, nicht nur im Vollschnitt
- saubere Nutflanken durch Spanformung
- Produktionssicherheit durch kontrollierten Spanablauf

Einsatzgebiete Applications

- Einstechen: Stechtiefe bis 25 mm
- Längsdrehen: Schnitttiefe a_p bis 2,5 mm*
- Grooving: Depth of groove up to 18 mm
- Side turning: Depth of cut a_p up to 2,5 mm*



- excellent swarf on a wide feed range
- excellent swarf control, also by partial cutting
- reduced swarf width gives high flank surface finish
- excellent swarf control allows production security

Vorschub f Feed rate f

- Einstechen: bis 0,3 mm/U*
- Längsdrehen: bis 0,3 mm/U*
- Grooving: up to 0,3 mm/rev*
- Side turning: up to 0,3 mm/rev*

* abhängig von der Plattenbreite
* dependent upon width of insert

Formwendeschneidplatten, Zwischenmaße oder andere Eckenradien sind auf Anfrage erhältlich!
Wendeschneidplatten sind in **rechten und linken** Klemmhaltern verwendbar.

Indexable inserts with profiles, intermediate sizes or other edge radii are available upon request.
Indexable inserts can be used in **right and left hand** toolholders.

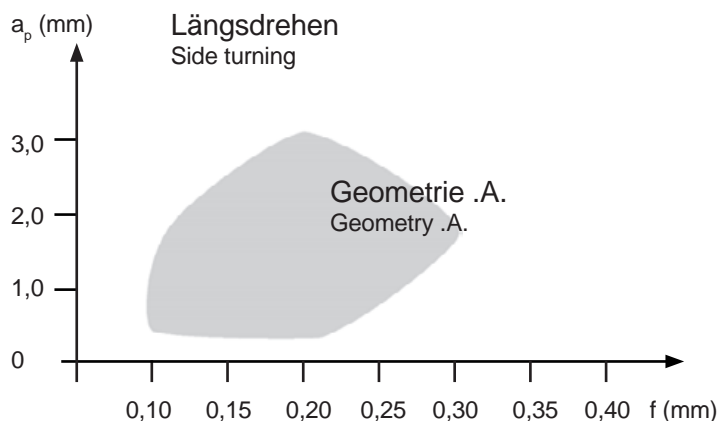

Spanbruchdiagramm S229.0500.A4, Werkstoff 16MnCr5
Chip control graph S229.0500.A4 material 16MnCr5

Einstechen und Längsdrehen

Grooving and Side Turning



Wendeschneidplatte

Indexable insert

S229

mit Spanformung
with chip forming



Stechtiefe bis Stechbreite	Depth of groove up to Width of groove	25 mm 3-10 mm
-------------------------------	--	------------------

präzisionsgesintert
precision sintered

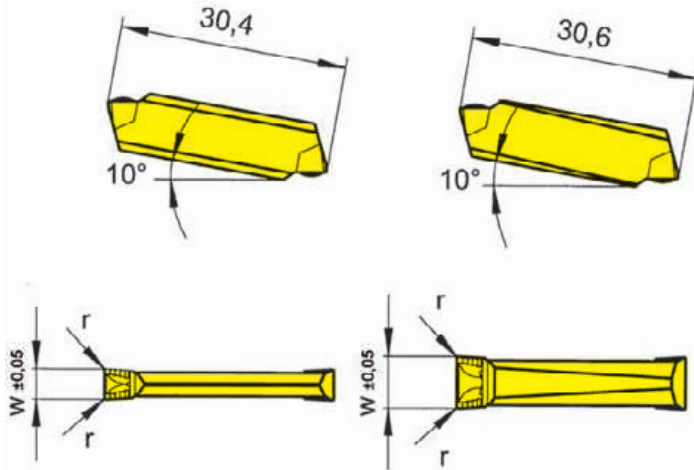

Schneidbreite 3,0 - 5,0 mm
Width 3,0 - 5,0 mm

Schneidbreite 6,0 - 10,0 mm
Width 6,0 - 10,0 mm

für Klemhalter
for Toolholder

- Typ 210
- Type 213
- 214
- 218
- 219
- 225
- 226
- 257
- R/LA210
- R/LA226

Wechselgenauigkeit
Länge ± 0,06 mm
Indexability length ± 0,06 mm

Bestellnummer Part number	w	r	Größe Size	AL96	AS62	P20	TC92	TF42	TF45	TI22	TI25	TN32	TN35
S229.0300.A2	3	0,2	03	Δ	▲	Δ	Δ		▲	▲	▲	▲	▲
S229.0300.A4	3	0,4	03	Δ	▲				▲	Δ	▲	▲	▲
S229.0400.A2	4	0,2	03/04	Δ	▲	Δ	Δ		▲	▲	▲	▲	▲
S229.0400.A4	4	0,4	03/04	Δ	▲		Δ	▲	Δ	▲	▲	▲	▲
S229.0500.A4	5	0,4	04		▲		Δ		Δ	▲	Δ	▲	▲
S229.0500.A6	5	0,6	04	Δ	▲		Δ				▲		
S229.0600.A4	6	0,4	05	Δ	▲	Δ	Δ	Δ	▲	▲	Δ	▲	▲
S229.0600.A8	6	0,8	05		▲			Δ					
S229.0700.A6	7	0,6	07				Δ	▲				Δ	
S229.0800.A6	8	0,6	07					Δ		▲		▲	
S229.0800.A8	8	0,8	07					Δ		Δ			
S229.0800.AK	8	1,2	07							Δ			
S229.1000.A6	10	0,6	09			Δ	x			Δ		Δ	
S229.1000.A8	10	0,8	09			x	x			Δ			

- ▲ ab Lager / on stock Δ 4 Wochen / 4 weeks x auf Anfrage / upon request
- empfohlen / recommended
- o bedingt einsetzbar / alternative recommendation
- nicht geeignet / not suitable
- unbeschichtete HM-Sorten / uncoated grades
- beschichtete HM-Sorten / coated grades
- bestückt/Cermet / brazed/Cermet

Abmessungen in mm
Dimensions in mm

Wendeschneidplatten sind in rechten und linken Klemmhaltern verwendbar.
Indexable inserts can be used in right and left hand toolholders.

P	●	●	●	●	●	●	●	●	●	●	●	●	●
M	-	-	-	-	-	-	-	-	●	-	●	-	●
K	●	-	-	-	-	-	-	-	-	-	●	-	●
N	●	-	-	-	-	-	-	-	-	-	●	-	●
S	-	-	-	-	-	-	-	-	●	-	●	-	●
H	-	-	-	-	-	-	-	-	-	-	-	-	-

HM-Sorten
Carbide grades



Einstechen und Abstechen

Grooving and Parting Off



Wendeschneidplatte

Indexable insert

S229

mit Spanformung
with chip forming

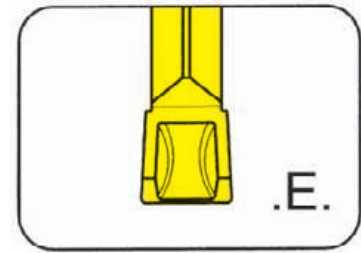

Stechtiefe bis Stechbreite	Depth of groove up to Width of groove	25 mm 3-4 mm
-------------------------------	--	-----------------

präzisionsgesintert
precision sintered

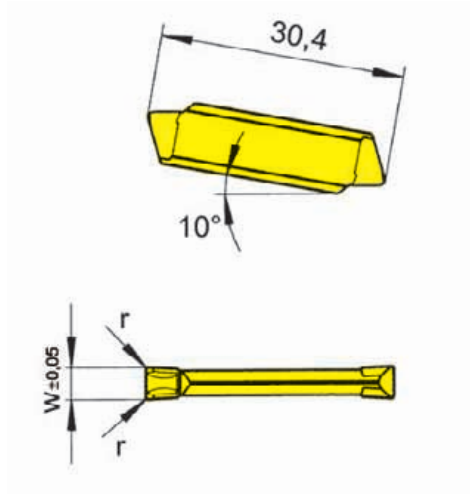

für Klemmhalter
for Toolholder

- Typ 210
Type 213
214
218
219
225
226
257
R/LA210
R/LA226

Wechselgenauigkeit
Länge ± 0,06 mm
Indexability length ± 0,06 mm

Bestellnummer Part number	w	r	Größe Size	HM-Sorten				
				AS62	TC92	TF45	TF46	TI25
S229.0300.E2	3	0,2	03	▲	▲	▲	▲	▲
S229.0300.E4	3	0,4	03	▲	▲	▲		
S229.0400.E2	4	0,2	03/04	▲	▲	▲	▲	▲
S229.0400.E4	4	0,4	03/04	▲	▲	▲		
P	•	•	•	•	•	•	•	•
M	-	-	•	o	•			
K	-	-	•	•	•			
N	-	-	•	•	•			
S	-	-	•	o	•			
H	-	-	-	-	-			

- ▲ ab Lager / on stock Δ 4 Wochen / 4 weeks x auf Anfrage / upon request
- empfohlen / recommended
- o bedingt einsetzbar / alternative recommendation
- nicht geeignet / not suitable
- unbeschichtete HM-Sorten / uncoated grades
- beschichtete HM-Sorten / coated grades
- bestückt/Cermet / brazed/Cermet

Abmessungen in mm
Dimensions in mm

Wendeschneidplatten sind in rechten und linken Klemmhaltern verwendbar.
Indexable inserts can be used in right and left hand toolholders.

HM-Sorten
Carbide grades

H

Einstechen und Abstechen

Grooving and Parting Off



Wendeschneidplatte

Indexable insert

S229

mit Spanformung
with chip forming

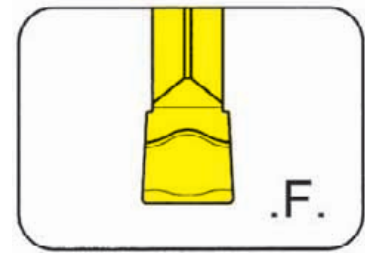

Stechtiefe bis Stechbreite	Depth of groove up to Width of groove	25 mm 3-4 mm
-------------------------------	--	-----------------

präzisionsgesintert
precision sintered

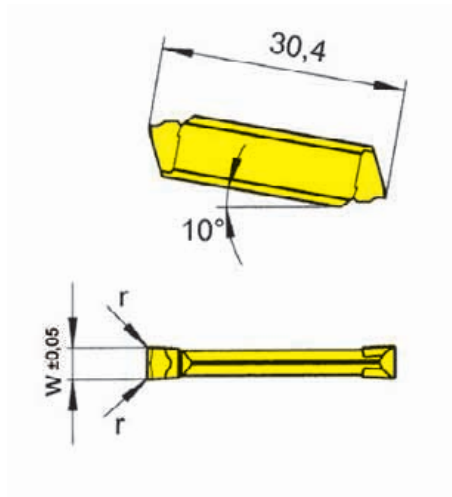

für Klemmhalter
for Toolholder

- Typ 210
Type 213
214
218
219
225
226
257
R/LA210
R/LA226

Wechselgenauigkeit
Länge ± 0,06 mm
Indexability length ± 0,06 mm

Bestellnummer Part number	w	r	Größe Size	TC92	TF43	TF45	TF46	TI22	TI25
S229.0300.F2	3	0,2	03	Δ	▲	▲	▲	▲	Δ
S229.0300.F4	3	0,4	03	Δ	Δ	▲	Δ	Δ	Δ
S229.0400.F2	4	0,2	03/04	Δ	Δ	▲	Δ	Δ	Δ
S229.0400.F4	4	0,4	03/04	Δ	Δ	▲	Δ	Δ	Δ
				P	●	●	●	●	●
				M	-	-	○	-	●
				K	-	-	●	-	●
				N	-	-	●	-	●
				S	-	-	○	-	●
				H	-	-	-	-	-

▲ ab Lager / on stock Δ 4 Wochen / 4 weeks x auf Anfrage / upon request

● empfohlen / recommended

○ bedingt einsetzbar / alternative recommendation

- nicht geeignet / not suitable

□ unbeschichtete HM-Sorten / uncoated grades

■ beschichtete HM-Sorten / coated grades

■ bestückt/Cermet / brazed/Cermet

Abmessungen in mm

Dimensions in mm

Wendeschneidplatten sind in rechten und linken Klemmhaltern verwendbar.

Indexable inserts can be used in right and left hand toolholders.

HM-Sorten
Carbide grades



Einstechen und Abstechen

Grooving and Parting Off



Wendeschneidplatte

Indexable insert

S229

mit Spanformung
with chip forming

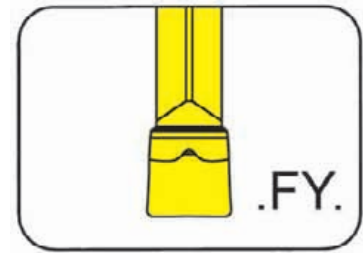

Stechtiefe bis Stechbreite	Depth of groove up to Width of groove	25 mm 3-4 mm
-------------------------------	--	-----------------

präzisionsgesintert
precision sintered

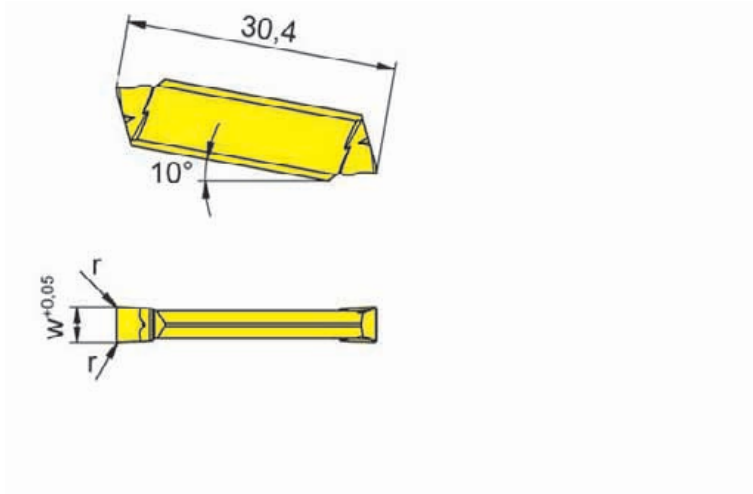

für Klemmhalter
for Toolholder

- Typ 210
Type 213
214
218
219
225
226
257
R/LA210
R/LA226

Wechselgenauigkeit
Länge ± 0,06 mm
Indexability length ± 0,06 mm

Bestellnummer Part number	w	r	Größe Size	HP65	PH35	Ti25
S229.0300.FY2	3	0,2	03	▲	▲	▲
S229.0400.FY3	4	0,3	03/04		▲	▲
				P ●	○	●
				M ●	○	●
				K ●	●	●
				N ○	-	●
				S ●	-	●
				H -	-	-

- ▲ ab Lager / on stock Δ 4 Wochen / 4 weeks x auf Anfrage / upon request
- empfohlen / recommended
- bedingt einsetzbar / alternative recommendation
- nicht geeignet / not suitable
- unbeschichtete HM-Sorten / uncoated grades
- beschichtete HM-Sorten / coated grades
- bestückt/Cermet / brazed/Cermet

Abmessungen in mm
Dimensions in mm

Wendeschneidplatten sind in rechten und linken Klemmhaltern verwendbar.
Indexable inserts can be used in right and left hand toolholders.

HM-Sorten
Carbide grades

H

Einstechen und Längsdrehen

Grooving and Side Turning



Wendeschneidplatte

Indexable insert

S229

mit Spantreppe
with chip breaker

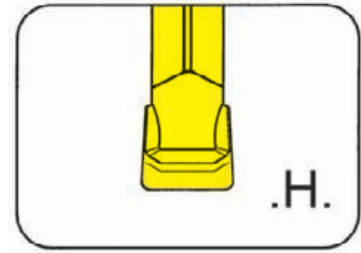

Stechtiefe bis Stechbreite	Depth of groove up to Width of groove	25 mm 3-6 mm
-------------------------------	--	-----------------

präzisionsgesintert
precision sintered

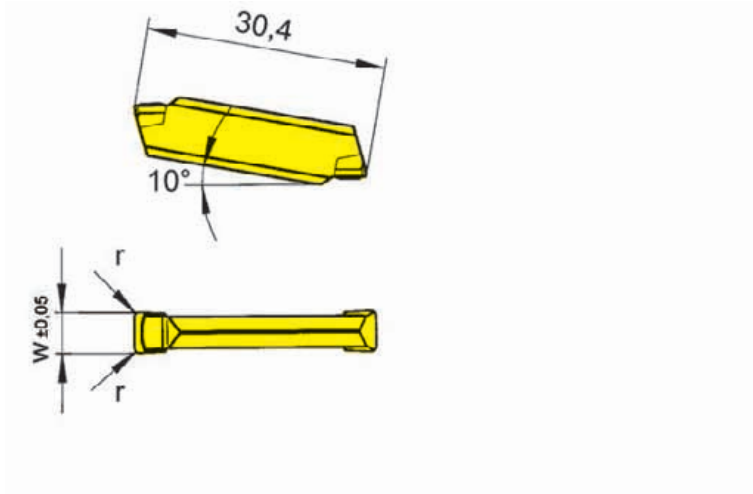

für Klemmhalter
for Toolholder

- Typ 210
Type 213
214
218
219
225
226
257
R/LA210
R/LA226

Wechselgenauigkeit
Länge ± 0,06 mm
Indexability length ± 0,06 mm

Bestellnummer Part number	w	r	Größe Size	AL96	TF42	TF46
S229.0300.H4	3	0,4	03	▲	△	
S229.0300.H6	3	0,6	03	▲	▲	
S229.0400.H4	4	0,4	03/04	△	▲	
S229.0400.H6	4	0,6	03/04	▲	▲	
S229.0400.H8	4	0,8	03/04	▲	▲	△
S229.0500.H4	5	0,4	04	△	▲	
S229.0500.H6	5	0,6	04	▲	△	
S229.0500.H8	5	0,8	04	△	△	
S229.0600.H4	6	0,4	05	△	▲	
S229.0600.H6	6	0,6	05	△	▲	
S229.0600.H8	6	0,8	05	△	▲	
S229.0600.HK	6	1,2	05	△	△	
				P	•	•
				M	-	o
				K	•	•
				N	•	•
				S	-	o
				H	-	-

- ▲ ab Lager / on stock △ 4 Wochen / 4 weeks x auf Anfrage / upon request
- empfohlen / recommended
- o bedingt einsetzbar / alternative recommendation
- nicht geeignet / not suitable
- unbeschichtete HM-Sorten / uncoated grades
- beschichtete HM-Sorten / coated grades
- bestückt/Cermet / brazed/Cermet

Abmessungen in mm
Dimensions in mm

Wendeschneidplatten sind in rechten und linken Klemmhaltern verwendbar.
Indexable inserts can be used in right and left hand toolholders.

HM-Sorten
Carbide grades



Einstechen und Längsdrehen

Grooving and Side Turning



Wendeschneidplatte

Indexable insert

S229

mit Spanformung
with chip forming

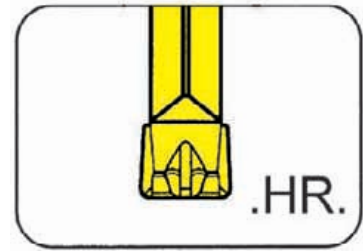

Stechtiefe bis Stechbreite	Depth of groove up to Width of groove	25 mm 3-8 mm
-------------------------------	--	-----------------

präzisionsgesintert
precision sintered

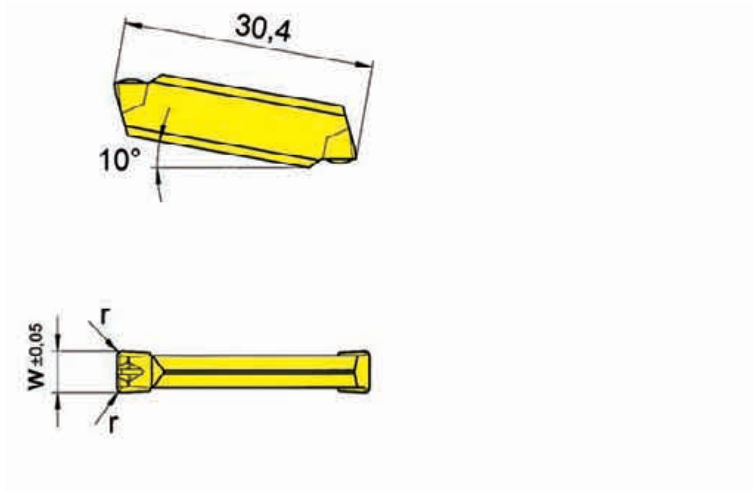

für Klemhalter
for Toolholder

Typ	210
Type	213
	214
	218
	219
	225
	226
	257
	R/LA210
	R/LA226

Wechselgenauigkeit
Länge ± 0,06 mm
Indexability length ± 0,06 mm

Bestellnummer Part number	w	r	Größe Size	AS62	AS66
S229.0300.HR4	3	0,4	03	▲	△
S229.0400.HR4	4	0,4	04	▲	▲
S229.0500.HR4	5	0,4	04	▲	△
S229.0500.HR6	5	0,6	04	▲	▲
S229.0500.HR8	5	0,8	04	▲	△
S229.0600.HR4	6	0,4	05	▲	▲
S229.0600.HR6	6	0,6	05	▲	▲
S229.0600.HR8	6	0,8	05	▲	△
S229.0800.HR8.PG	8	0,8	07/08	▲	

▲ ab Lager / on stock △ 4 Wochen / 4 weeks x auf Anfrage / upon request

● empfohlen / recommended

o bedingt einsetzbar / alternative recommendation

- nicht geeignet / not suitable

■ unbeschichtete HM-Sorten / uncoated grades

■ beschichtete HM-Sorten / coated grades

■ bestückt/Cermet / brazed/Cermet

Abmessungen in mm

Dimensions in mm

Wendeschneidplatten sind in rechten und linken Klemmaltern verwendbar.

Indexable inserts can be used in right and left hand toolholders.

P	●	●
M	-	○
K	-	●
N	-	●
S	-	○
H	-	-

HM-Sorten
Carbide grades

Einstechen und Längsdrehen

Grooving and Side Turning



Wendeschneidplatte

Indexable insert

S229

mit Spanformung
with chip forming

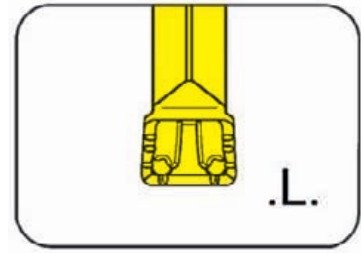

Stechtiefe bis Stechbreite	Depth of groove up to Width of groove	25 mm 4-8 mm
-------------------------------	--	-----------------

präzisionsgesintert
precision sintered

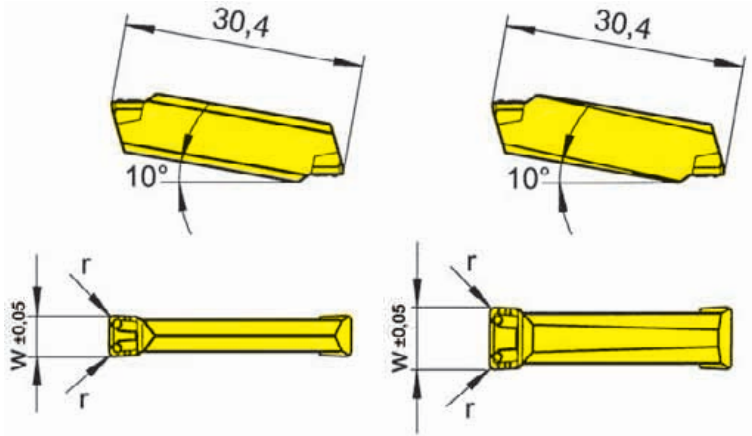

Schneidbreite 4,0 - 5,0 mm
Width 4,0 - 5,0 mm

Schneidbreite 6,0 - 8,0 mm
Width 6,0 - 8,0 mm

für Klemhalter
for Toolholder

- Typ 210
- Type 213
- 214
- 218
- 219
- 225
- 226
- 257
- R/LA210
- R/LA226

Wechselgenauigkeit
Länge ± 0,06 mm
Indexability length ± 0,06 mm

Bestellnummer Part number	w	r	Größe Size	AL96	AS62	AS66	TF42	Ti22
S229.0400.L4	4	0,4	03/04	▲	▲	▲	▲	▲
S229.0400.L6	4	0,6	03/04			▲		
S229.0500.L4	5	0,4	04	▲	▲	▲	▲	▲
S229.0500.L6	5	0,6	04	▲	▲	▲	▲	△
S229.0500.L8	5	0,8	04		▲	▲		
S229.0600.L4	6	0,4	05	▲	▲	▲	▲	▲
S229.0600.L6	6	0,6	05	▲	▲	▲	▲	▲
S229.0800.L6	8	0,6	08	▲	▲	▲	▲	▲

- ▲ ab Lager / on stock Δ 4 Wochen / 4 weeks x auf Anfrage / upon request
- empfohlen / recommended
- o bedingt einsetzbar / alternative recommendation
- nicht geeignet / not suitable
- unbeschichtete HM-Sorten / uncoated grades
- beschichtete HM-Sorten / coated grades
- bestückt/Cermet / brazed/Cermet

P	●	●	●	●	●
M	-	-	o	-	-
K	●	-	●	-	-
N	●	-	●	-	-
S	-	-	o	-	-
H	-	-	-	-	-

Abmessungen in mm
Dimensions in mm

Wendeschneidplatten sind in rechten und linken Klemmhaltern verwendbar.
Indexable inserts can be used in right and left hand toolholders.

HM-Sorten
Carbide grades



Einstechen und Längsdrehen

Grooving and Side Turning



Wendeschneidplatte

Indexable insert

S229

mit Spanformung
with chip forming

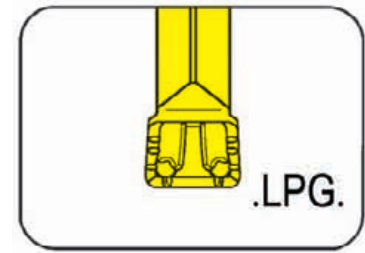

Stechtiefe bis Stechbreite	Depth of groove up to Width of groove	25 mm 6-8 mm
-------------------------------	--	-----------------

präzisionsgesintert
precision sintered

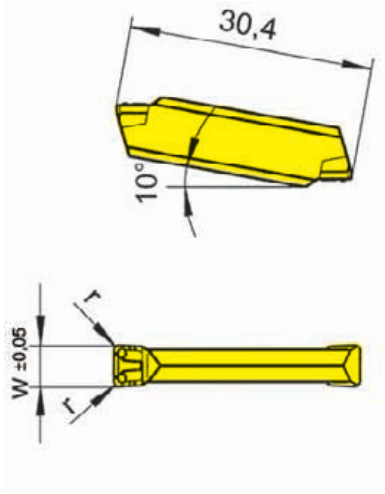

für Klemmhalter
for Toolholder

Typ 210
Type 213
214
218
219
225
226
257
R/LA210
R/LA226

Wechselgenauigkeit
Länge ± 0,06 mm
Indexability length ± 0,06 mm

PG = Schneide ist umfanggeschliffen
PG = inserts with ground periphery

Bestellnummer Part number	w	r	Größe Size	AS62
S229.0600.L4.PG	6	0,4	05	▲
S229.0800.L8.PG	8	0,8	07	▲

- ▲ ab Lager / on stock Δ 4 Wochen / 4 weeks x auf Anfrage / upon request
- empfohlen / recommended
- o bedingt einsetzbar / alternative recommendation
- nicht geeignet / not suitable
- unbeschichtete HM-Sorten / uncoated grades
- beschichtete HM-Sorten / coated grades
- bestückt/Cermet / brazed/Cermet

Abmessungen in mm
Dimensions in mm

Wendeschneidplatten sind in rechten und linken Klemmhaltern verwendbar.
Indexable inserts can be used in right and left hand toolholders.

HM-Sorten
Carbide grades

P	•
M	-
K	-
N	-
S	-
H	-

H

Einstechen und Längsdrehen

Grooving and Side Turning



Wendeschneidplatte

Indexable insert

S229

mit Spanformung
with chip forming

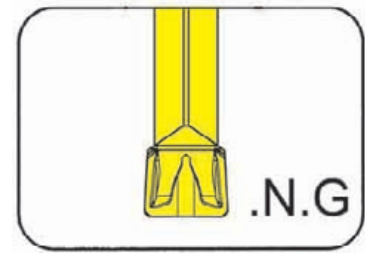

Stechtiefe bis Stechbreite	Depth of groove up to Width of groove	25 mm 3-6 mm
-------------------------------	--	-----------------

präzisionsgesintert
precision sintered

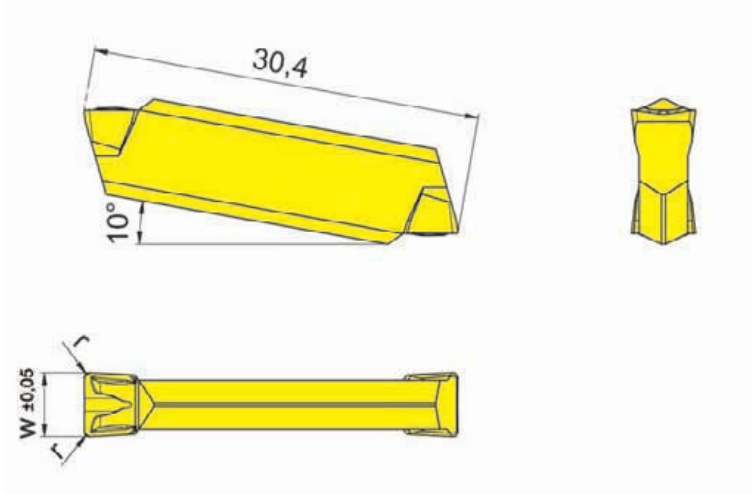

für Klemmhalter
for Toolholder

- Typ 210
Type 213
214
218
219
225
226
257
R/LA210
R/LA226

Wechselgenauigkeit
Länge ± 0,06 mm
Indexability length ± 0,06 mm

Bestellnummer Part number	w	r	Größe Size	AS45	AS62	DD25	TI25
S229.0300.N2.G	3	0,2	03	▲			
S229.0300.N4.G	3	0,4	03	▲			
S229.0400.N2.G	4	0,2	03/04	▲			
S229.0400.N4.G	4	0,4	03/04	▲			
S229.0500.N2.G	5	0,2	04			△	△
S229.0500.N4.G	5	0,4	04	▲	▲	△	△
S229.0500.N6.G	5	0,6	04	▲	△		△
S229.0500.N8.G	5	0,8	04		▲		
S229.0600.N4.G	6	0,4	05	▲			△
S229.0600.N6.G	6	0,6	05	▲			△
P	●	●	-	●			
M	●	-	-	●			
K	●	-	-	●			
N	○	-	●	●			
S	●	-	○	●			
H	-	-	-	-			

▲ ab Lager / on stock △ 4 Wochen / 4 weeks x auf Anfrage / upon request

● empfohlen / recommended

○ bedingt einsetzbar / alternative recommendation

- nicht geeignet / not suitable

■ unbeschichtete HM-Sorten / uncoated grades

■ beschichtete HM-Sorten / coated grades

■ bestückt/Cermet / brazed/Cermet

Abmessungen in mm

Dimensions in mm

Wendeschneidplatten sind in rechten und linken Klemmhaltern verwendbar.

Indexable inserts can be used in right and left hand toolholders.

HM-Sorten
Carbide grades



Einstechen und Längsdrehen

Grooving and Side Turning



Wendeschneidplatte

Indexable insert

S229

mit Spanformung
with chip forming

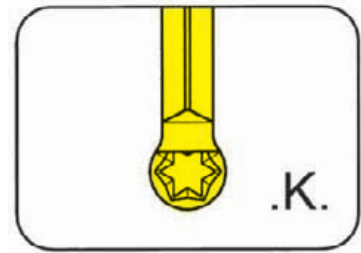

Stechtiefe bis	Depth of groove up to	25 mm
Stechbreite	Width of groove	3-8 mm
Vollradius	Full radius	1,5-4 mm

präzisionsgesintert
precision sintered

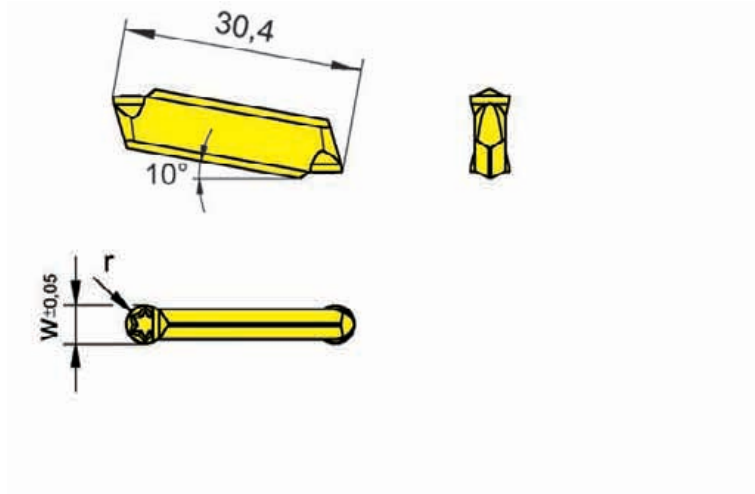

für Klemhalter
for Toolholder

- Typ 210
Type 213
214
218
219
225
226
257
R/LA210
R/LA226

Wechselgenauigkeit
Länge ± 0,06 mm
Indexability length ± 0,06 mm

Bestellnummer Part number	w	r	Größe Size	AS62	AS66
S229.0015.K3	3	1,5	02/03	▲	▲
S229.0020.K4	4	2,0	03/04	▲	▲
S229.0025.K5	5	2,5	04	▲	▲
S229.0030.K6	6	3,0	05	▲	▲
S229.0040.K8	8	4,0	07/08	▲	▲

▲ ab Lager / on stock Δ 4 Wochen / 4 weeks x auf Anfrage / upon request

● empfohlen / recommended

o bedingt einsetzbar / alternative recommendation

- nicht geeignet / not suitable

■ unbeschichtete HM-Sorten / uncoated grades

■ beschichtete HM-Sorten / coated grades

■ bestückt/Cermet / brazed/Cermet

Abmessungen in mm

Dimensions in mm

Wendeschneidplatten sind in rechten und linken Klemmhaltern verwendbar.

Indexable inserts can be used in right and left hand toolholders.

	AS62	AS66
P	●	●
M	-	○
K	-	●
N	-	●
S	-	○
H	-	-

HM-Sorten
Carbide grades

D_{min} für Eckenfreistriche in Verbindung mit Klemmhalter unter 45°
D_{min} for corner reliefs with toolholder 45°

t _{max}	S229.0015.K3	S229.0020.K4	S229.0025.K5	S229.0030.K6
0,5	Ø 26	Ø 26	Ø 32	Ø 32
1,0	Ø 76	Ø 55	Ø 42	Ø 37
1,5	Ø 78	Ø 58	Ø 45	Ø 41
2,0	Ø 80	Ø 59	Ø 46	Ø 42
2,5	Ø 82	Ø 60	Ø 47	Ø 43
3,0	Ø 84	Ø 62	Ø 48	Ø 44
3,5	Ø 87	Ø 63	Ø 49	Ø 46
4,0	Ø 89	Ø 65	Ø 50	Ø 47

Einstechen und Längsdrehen

Grooving and Side Turning



Wendeschneidplatte

Indexable insert

S229

mit Spanformung
with chip forming

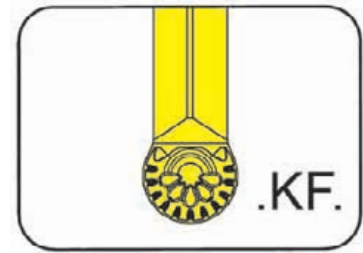

Stechtiefe bis Stechbreite Vollradius	Depth of groove up to Width of groove Full radius	25 mm 3-8 mm 1,5-4 mm
---	---	-----------------------------

präzisionsgesintert
precision sintered

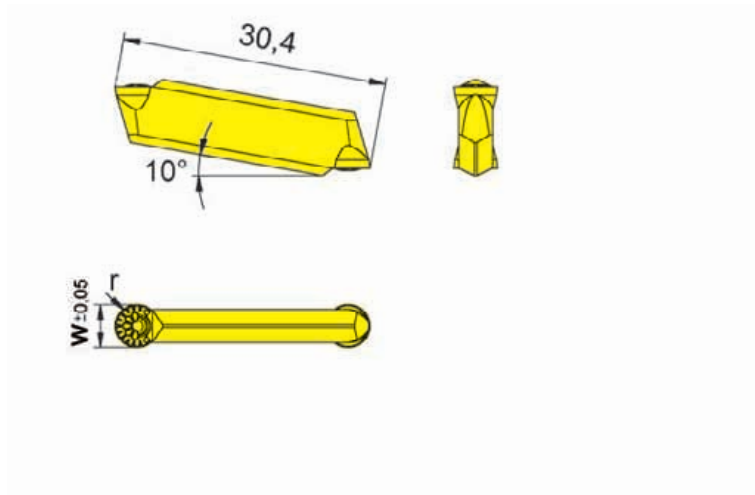

für Klemhalter
for Toolholder

- Typ 210
Type 213
214
218
219
225
226
257
R/LA210
R/LA226

Wechselgenauigkeit
Länge ± 0,06 mm
Indexability length ± 0,06 mm

Bestellnummer Part number	w	r	Größe Size	AS66
S229.0015.KF3	3	1,5	02/03	▲
S229.0020.KF4	4	2,0	03/04	▲
S229.0025.KF5	5	2,5	04	▲
S229.0030.KF6	6	3,0	05	▲
S229.0040.KF8	8	4,0	07/08	△

▲ ab Lager / on stock Δ 4 Wochen / 4 weeks x auf Anfrage / upon request

● empfohlen / recommended

o bedingt einsetzbar / alternative recommendation

- nicht geeignet / not suitable

■ unbeschichtete HM-Sorten / uncoated grades

■ beschichtete HM-Sorten / coated grades

■ bestückt/Cermet / brazed/Cermet

P	●
M	○
K	●
N	●
S	○
H	-

HM-Sorten
Carbide grades

Abmessungen in mm

Dimensions in mm

Wendeschneidplatten sind in rechten und linken Klemmaltern verwendbar.

Indexable inserts can be used in right and left hand toolholders.

D_{min} für Eckenfreistriche in Verbindung mit Klemmaltern unter 45°
D_{min} for corner reliefs with toolholder 45°

t _{max}	S229.0015.KF3	S229.0020.KF4	S229.0025.KF5	S229.0030.KF6
0,5	Ø 26	Ø 26	Ø 32	Ø 32
1,0	Ø 76	Ø 55	Ø 42	Ø 37
1,5	Ø 78	Ø 58	Ø 45	Ø 41
2,0	Ø 80	Ø 59	Ø 46	Ø 42
2,5	Ø 82	Ø 60	Ø 47	Ø 43
3,0	Ø 84	Ø 62	Ø 48	Ø 44
3,5	Ø 87	Ø 63	Ø 49	Ø 46
4,0	Ø 89	Ø 65	Ø 50	Ø 47

Wendeschneidplatte

Indexable insert

229...10

präzisionsgeschliffen
precision ground



Geometrie .10

Geometry

Leichtschneidende Geometrie ohne Spanformung
Easy cutting geometry without chip former

Hauptmerkmale Characteristics

- leichtschneidend - geringe Leistungsaufnahme
- geeignet für labile Teile
- für Innenbearbeitung bei engen Verhältnissen
- geeignet für geringste Vorschübe
- easy cutting - low power requirement
- suitable for unstable parts
- for internal grooving in restricted bores
- suitable for low feeds

Einsatzgebiete Applications

- Einstechen: Stechtiefe bis 25 mm
- Grooving: Depth of groove up to 18 mm

Vorschub f Feed rate f

- Einstechen: bis 0,3 mm/U
- Grooving: up to 0,3 mm/rev

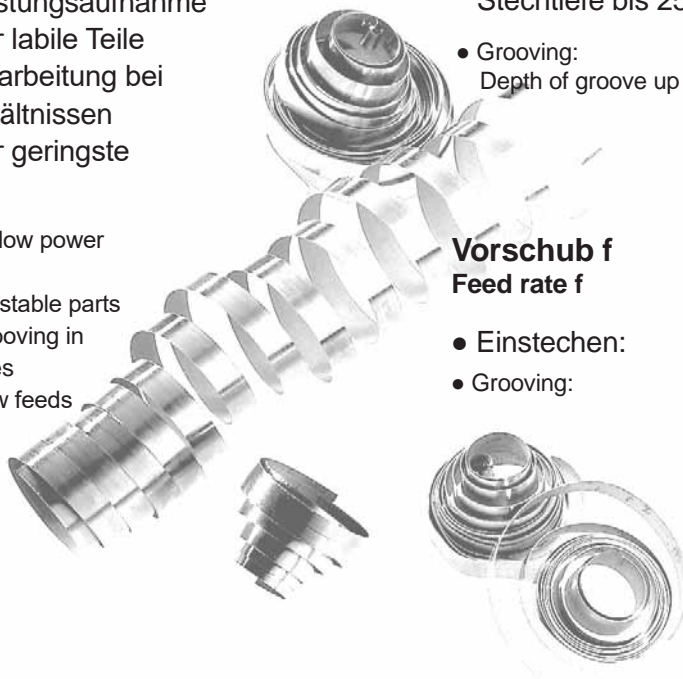

Konturdrehen mit Aufmaß in Größe der Eckenradien ist möglich.
Formwendeschneidplatten, Zwischenmaße oder andere Eckenradien sind auf Anfrage erhältlich!
Wendeschneidplatten sind in **rechten und linken** Klemmhaltern verwendbar.

Profiling with a cutting depth of the edge radius is possible.
Indexable inserts with profiles, intermediate sizes or other edge radii are available upon request.
Indexable inserts can be used in **right and left hand** toolholders.

Einstechen und Längsdrehen

Grooving and Side Turning



Wendeschneidplatte

Indexable insert

229

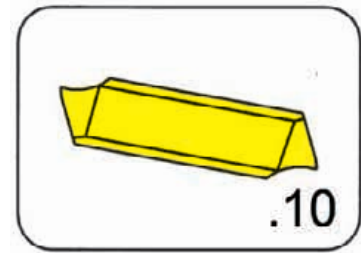

Stechtiefe bis Stechbreite	Depth of groove up to Width of groove	25 mm 2,5 - 10 mm
-------------------------------	--	----------------------

präzisionsgeschliffen
precision ground

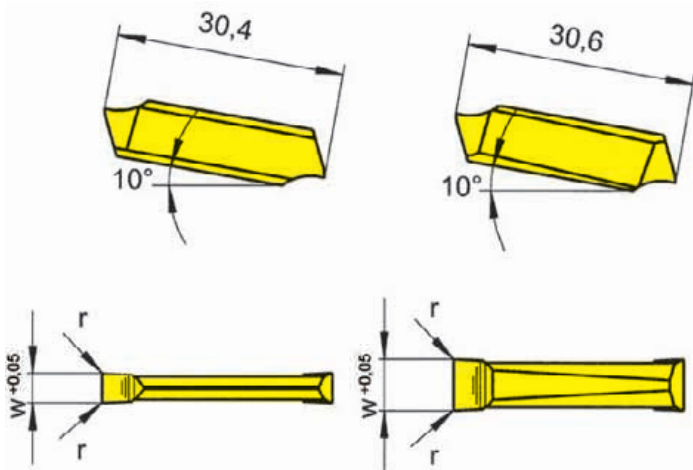

Schneidbreite 2,5 - 5,0 mm
Width 2,5 - 5,0 mm

Schneidbreite 5,1 - 10,4 mm
Width 5,1 - 10,4 mm

für Klemhalter
for Toolholder

- Typ 210
Type 213
214
218
219
225
226
257
R/LA210
R/LA226

Wechselgenauigkeit
Länge ± 0,025 mm
Indexability length ± 0,025 mm

Bestellnummer Part number	w	r	Größe Size	Material									
				K10	MG12	AS62	H20	P20	TC92	TN32	TN35		
229.0250.10	2,5	0,2	02										
229.0300.10	3,0	0,2	03	▲	▲	▲	▲	▲	▲	▲	▲	▲	▲
229.0400.10	4,0	0,2	03/04	▲		▲		▲	▲	▲	▲	▲	▲
229.0500.10	5,0	0,2	04	▲		▲		▲	▲	▲	▲	▲	▲
229.0600.10	6,0	0,4	05	▲				▲	▲	▲	▲	▲	▲
229.0700.10	7,0	0,4	07	▲				▲	▲	▲	▲	▲	▲
229.0800.10	8,0	0,4	07	▲				▲	▲	▲	▲	▲	▲
229.0900.10	9,0	0,4	09	▲				▲	▲	▲	▲	▲	▲
229.1000.10	10,0	0,4	09	▲				▲	▲	▲	▲	▲	▲
▲ ab Lager / on stock Δ 4 Wochen / 4 weeks x auf Anfrage / upon request				P	●	○	●	●	●	●	●	●	●
● empfohlen / recommended				M	○	●	-	○	-	-	-	-	●
○ bedingt einsetzbar / alternative recommendation				K	●	●	-	-	-	-	-	-	●
- nicht geeignet / not suitable				N	●	●	-	-	-	-	-	-	●
■ unbeschichtete HM-Sorten / uncoated grades				S	○	●	-	-	-	-	-	-	●
■ beschichtete HM-Sorten / coated grades				H	-	-	-	-	-	-	-	-	-
■ bestückt/Cermet / brazed/Cermet													

Abmessungen in mm
Dimensions in mm

Wendeschneidplatten sind in rechten und linken Klemmaltern verwendbar.
Indexable inserts can be used in right and left hand toolholders.

HM-Sorten
Carbide grades



Wendeschneidplatte

Indexable insert

229...20

präzisionsgeschliffen
precision ground



Geometrie .20

Geometry

Geometrie ohne Spanformung für Grauguss und hochfeste Werkstoffe
Geometry without chip forming for grey cast iron and materials with higher tensile strength

Hauptmerkmale Characteristics

- stabiler Keilwinkel
- geeignet für Form-WSP mit größerer Formtiefe
- für unterbrochenen Schnitt zu empfehlen
- geeignet für geringe Vorschübe

- strong wedge angle
- for inserts with larger depth of profile
- recommended for interrupted cut
- suitable for low feeds

Einsatzgebiete Applications

- Einstechen:
Stechtiefe bis 25 mm
- Grooving:
Depth of groove up to 25 mm

Vorschub f Feed rate f

- Einstechen: 0,07 bis 0,25 mm/U
- Grooving: 0,07 up to 0,25 mm/rev

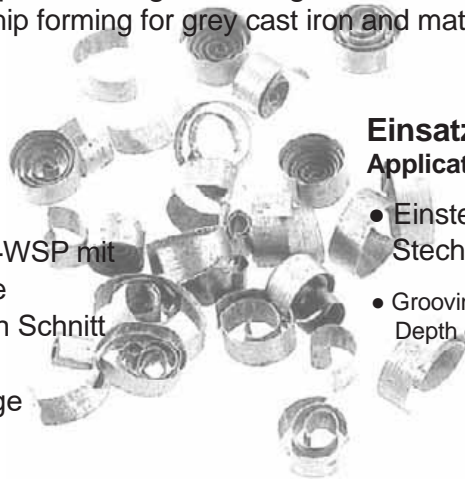

Konturdrehen mit Aufmaß in Größe der Eckenradien ist möglich.
Formwendeschneidplatten, Zwischenmaße oder andere Eckenradien sind auf Anfrage erhältlich!
Wendeschneidplatten sind in **rechten und linken** Klemmhaltern verwendbar.

Profiling with a cutting depth of the edge radius is possible.
Indexable inserts with profiles, intermediate sizes or other edge radii are available upon request.
Indexable inserts can be used in **right and left hand** toolholders.

Einstechen und Längsdrehen

Grooving and Side Turning



Wendeschneidplatte

Indexable insert

229

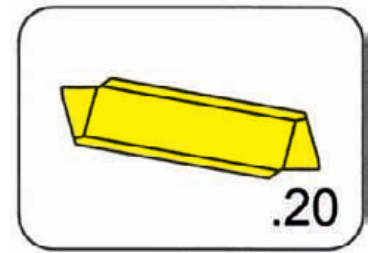

Stechtiefe bis Stechbreite	Depth of groove up to Width of groove	25 3-10 mm
-------------------------------	--	---------------

präzisionsgeschliffen
precision ground

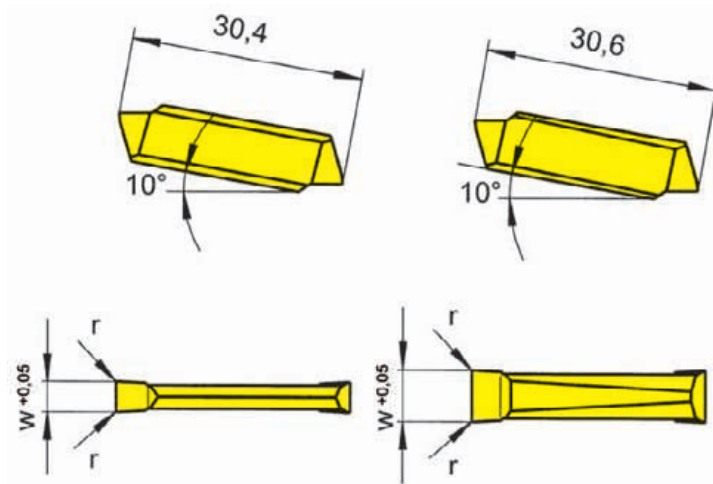

Schneidbreite 3,0 - 5,0 mm
Width 3,0 - 5,0 mm

Schneidbreite 5,1 - 10,4 mm
Width 5,1 - 10,4 mm

für Klemhalter
for Toolholder

- Typ 210
Type 213
214
218
219
225
226
257
R/LA210
R/LA226

Wechselgenauigkeit
Länge ± 0,025 mm
Indexability length ± 0,025 mm

Bestellnummer Part number	w	r	Größe Size					
				K10	AS62	H20	TC92	TN32
229.0300.20	3	0,2	03	▲	▲	▲	▲	▲
229.0400.20	4	0,2	03/04	▲	▲	▲	▲	▲
229.0500.20	5	0,2	04	▲	▲	▲	▲	▲
229.0600.20	6	0,4	05	▲	▲	▲	▲	▲
229.0700.20	7	0,4	07	▲	▲	▲	▲	▲
229.0800.20	8	0,4	07	▲	▲	▲	▲	▲
229.0900.20	9	0,4	09	▲	▲	▲	▲	▲
229.1000.20	10	0,4	09	▲	▲	▲	▲	▲

- ▲ ab Lager / on stock Δ 4 Wochen / 4 weeks x auf Anfrage / upon request
- empfohlen / recommended
- o bedingt einsetzbar / alternative recommendation
- nicht geeignet / not suitable
- unbeschichtete HM-Sorten / uncoated grades
- beschichtete HM-Sorten / coated grades
- bestückt/Cermet / brazed/Cermet

Abmessungen in mm
Dimensions in mm

Wendeschneidplatten sind in rechten und linken Klemmaltern verwendbar.
Indexable inserts can be used in right and left hand toolholders.

P	●	●	●	●	●
M	o	-	o	-	-
K	●	-	-	-	-
N	●	-	-	-	-
S	o	-	-	-	-
H	-	-	-	-	-

HM-Sorten
Carbide grades



Wendeschneidplatte

Indexable insert

229...3.

präzisionsgeschliffen
precision ground



Geometrie .3.

Geometrie mit Spanformrille für alle Werkstoffe.
Geometry with chip forming for all materials.

Hauptmerkmale Characteristics

- sichere Spankontrolle (Spanrolle)
- universell einsetzbar - auch für Werkstoffe mit höherer Festigkeit
- saubere Nutflanken durch Spanformung
- Produktionssicherheit durch kontrollierten Spanablauf

Einsatzgebiete Applications

- Einstechen:
Stechtiefe bis 25 mm
- Längsdrehen:
Schnittiefe a_p bis 4 mm*
- Grooving:
Depth of groove up to 25 mm
- Side turning:
Depth of cut a_p up to 4 mm*

- excellent swarf control
- suitable for high alloy- high strength steels
- reduced swarf width gives high flank surface finish
- excellent swarf control allows production security

Vorschub f Feed rate f

- Einstechen: 0,15 bis 0,25 mm/U*
- Längsdrehen: bis 0,4 mm/U*
- Grooving: 0,15 up to 0,25 mm/rev*
- Side turning: up to 0,4 mm/rev*

* abhängig von der Plattenbreite
* dependent upon width of insert

Formwendeschneidplatten, Zwischenmaße oder andere Eckenradien sind auf Anfrage erhältlich!
Wendeschneidplatten sind in **rechten und linken** Klemmhaltern verwendbar.

Indexable inserts with profiles, intermediate sizes or other edge radii are available upon request.
Indexable inserts can be used in **right and left hand** toolholders.

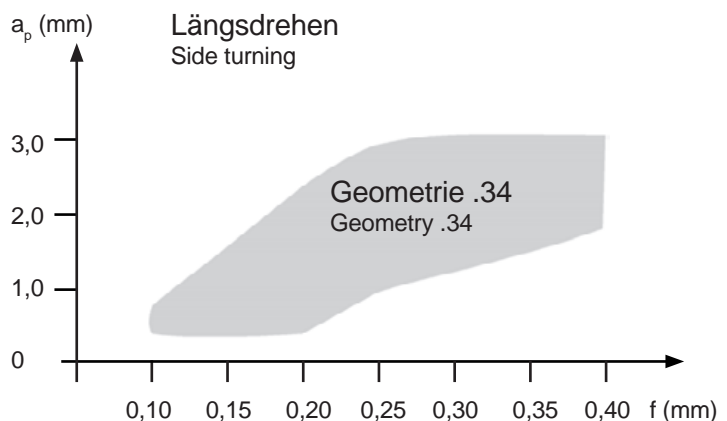

Spanbruchdiagramm 229.0500.34, Werkstoff 16MnCr5
Chip control graph 229.0500.34 material 16MnCr5

Einstechen und Längsdrehen

Grooving and Side Turning



Wendeschneidplatte

Indexable insert

229

mit Spanformrinne
with chip former

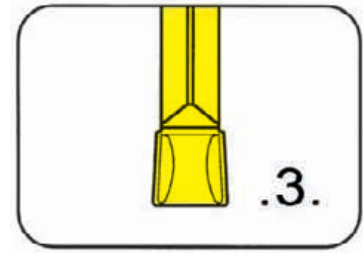

Stechtiefe bis
Stechbreite

Depth of groove up to
Width of groove

25
3-10 mm

präzisionsgeschliffen
precision ground

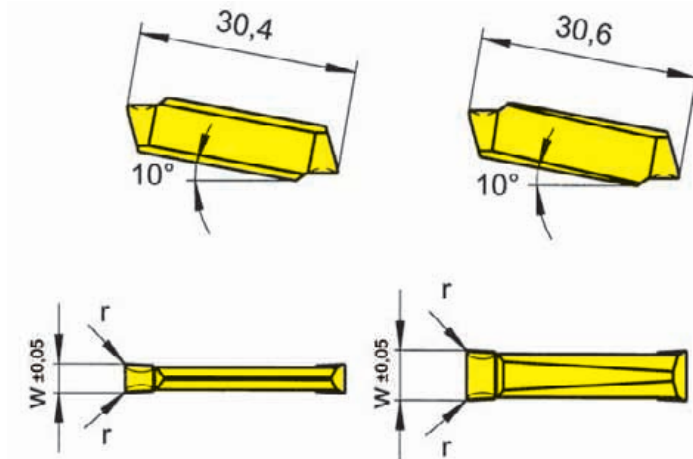

Schneidbreite 3,0 - 5,0 mm
Width 3,0 - 5,0 mm

Schneidbreite 5,1 - 10,4 mm
Width 5,1 - 10,4 mm

für Klemhalter
for Toolholder

Typ 210
Type 213
214
218
219
225
226
257
R/LA210
R/LA226

Wechselgenauigkeit
Länge ± 0,025 mm
Indexability length ± 0,025 mm

Bestellnummer Part number	w	r	Größe Size	K10	MG12	AS62	P20	TC92	TI22	TI25	TN32	TN35
229.0300.31	3,0	0,2	03	▲	▲	▲	▲	▲		▲	▲	▲
229.0300.34	3,0	0,4	04			▲	△	△			▲	▲
229.0350.31	3,5	0,2	03					△			▲	
229.0400.31	4,0	0,2	03/04	▲		▲	▲	▲			▲	
229.0400.34	4,0	0,4	04			▲	▲	△			▲	▲
229.0500.31	5,0	0,2	04	▲		▲	▲	△	▲		▲	
229.0500.34	5,0	0,4	04			△	△	△			▲	▲
229.0500.36	5,0	0,6	04					△			△	
229.0600.31	6,0	0,4	05			△	▲	▲			▲	
229.0600.38	6,0	0,8	05			△		△			△	
229.0700.31	7,0	0,4	07			△	△	△			▲	
229.0800.31	8,0	0,4	07			▲	▲	▲			▲	
229.0900.31	9,0	0,4	09			▲	△	▲			▲	
229.1000.31	10,0	0,4	09			▲	△	△			▲	▲
P	●	○	●	●	●	●	●	●	●	●	●	●
M	○	●	-	-	-	-	-	-	-	●	-	●
K	●	●	-	-	-	-	-	-	-	●	-	●
N	●	●	-	-	-	-	-	-	-	●	-	●
S	○	●	-	-	-	-	-	-	-	●	-	●
H	-	-	-	-	-	-	-	-	-	-	-	-

▲ ab Lager / on stock △ 4 Wochen / 4 weeks x auf Anfrage / upon request
 ● empfohlen / recommended
 ○ bedingt einsetzbar / alternative recommendation
 - nicht geeignet / not suitable
 ■ unbeschichtete HM-Sorten / uncoated grades
 ■ beschichtete HM-Sorten / coated grades
 ■ bestückt/Cermet / brazed/Cermet

Abmessungen in mm
Dimensions in mm

Wendeschneidplatten sind in rechten und linken Klemmaltern verwendbar.
Indexable inserts can be used in right and left hand toolholders.

HM-Sorten
Carbide grades



NC-Universaldrehplatte

Finishing on NC-Lathes



Wendeschneidplatte

Indexable insert

229

mit Spantreppe
with chip breaker

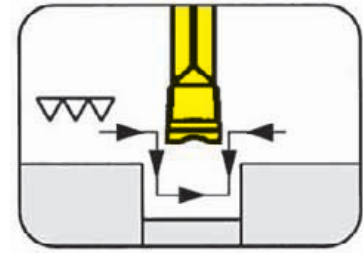

Stechtiefe bis
Stechbreite

Depth of groove up to
Width of groove

25 mm
3-4 mm

präzisionsgeschliffen
precision ground

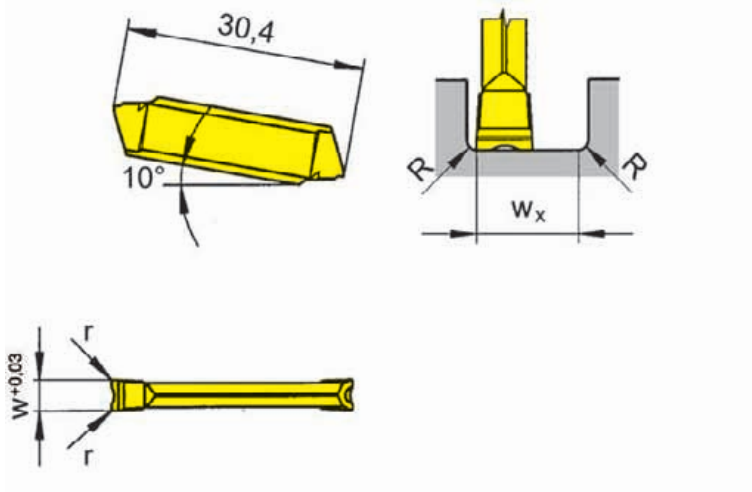

für Klemmhalter
for Toolholder

Typ 210
Type 213
214
218
219
225
226
257
R/LA210
R/LA226

Wechselgenauigkeit
Länge $\pm 0,025$ mm
Indexability length $\pm 0,025$ mm

Bestellnummer Part number	w	r	w _x	Größe Size	H20
229.NC30.02	3	0,2	4,5	03/04	▲
229.NC40.02	4	0,2	6,4	03/04	▲

▲ ab Lager / on stock Δ 4 Wochen / 4 weeks x auf Anfrage / upon request

● empfohlen / recommended

o bedingt einsetzbar / alternative recommendation

- nicht geeignet / not suitable

■ unbeschichtete HM-Sorten / uncoated grades

■ beschichtete HM-Sorten / coated grades

■ bestückt/Cermet / brazed/Cermet

Abmessungen in mm

Dimensions in mm

$w_x = \text{Nutbreite} - R_{(\text{rechts})} - R_{(\text{links})}$

$w_x = \text{width of groove} - R_{(\text{right})} - R_{(\text{left})}$

Wendeschneidplatten sind in rechten und linken Klemmhaltern verwendbar.

Indexable inserts can be used in right and left hand toolholders.

P	•
M	o
K	-
N	-
S	-
H	-

HM-Sorten
Carbide grades

H

Einstechen und Längsdrehen

Grooving and Side Turning



Wendeschneidplatte

Indexable insert

229

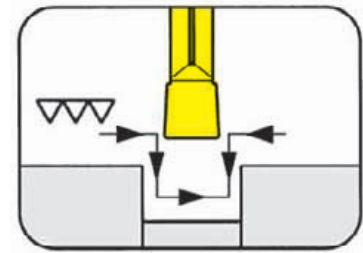

Stechtiefe bis Stechbreite	Depth of groove up to Width of groove	25 mm 3-4 mm
-------------------------------	--	-----------------

präzisionsgeschliffen
precision ground

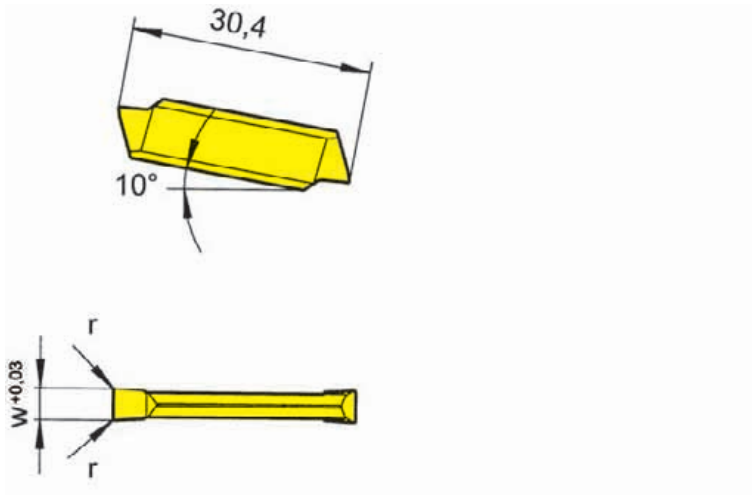

für Klemmhalter
for Toolholder

- Typ 210
Type 213
214
218
219
225
226
257
R/LA210
R/LA226

Wechselgenauigkeit
Länge $\pm 0,025$ mm
Indexability length $\pm 0,025$ mm

Bestellnummer Part number	w	r	Größe Size	H20	TN32
229.0300.02	3	0,2	03/04	▲	▲
229.0400.02	4	0,2	03/04	▲	▲

- ▲ ab Lager / on stock Δ 4 Wochen / 4 weeks x auf Anfrage / upon request
- empfohlen / recommended
- o bedingt einsetzbar / alternative recommendation
- nicht geeignet / not suitable
- unbeschichtete HM-Sorten / uncoated grades
- beschichtete HM-Sorten / coated grades
- bestückt/Cermet / brazed/Cermet

Abmessungen in mm
Dimensions in mm

Wendeschneidplatten sind in rechten und linken Klemmhaltern verwendbar.
Indexable inserts can be used in right and left hand toolholders.

P	●	●
M	○	-
K	-	-
N	-	-
S	-	-
H	-	-

HM-Sorten
Carbide grades



Einstecken (außen und innen)

Grooving (external and internal)



Wendeschneidplatte

Indexable insert

229

mit umlaufender Spantreppe
with surrounding chip breaker

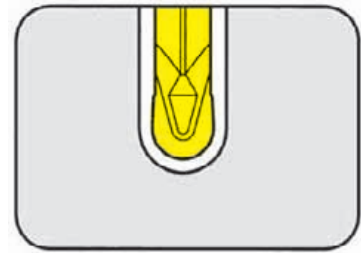

Stechtiefe bis Vollradius	Depth of groove up to Full radius	25 mm 1,5-3 mm
---------------------------	-----------------------------------	-------------------

präzisionsgeschliffen
precision ground

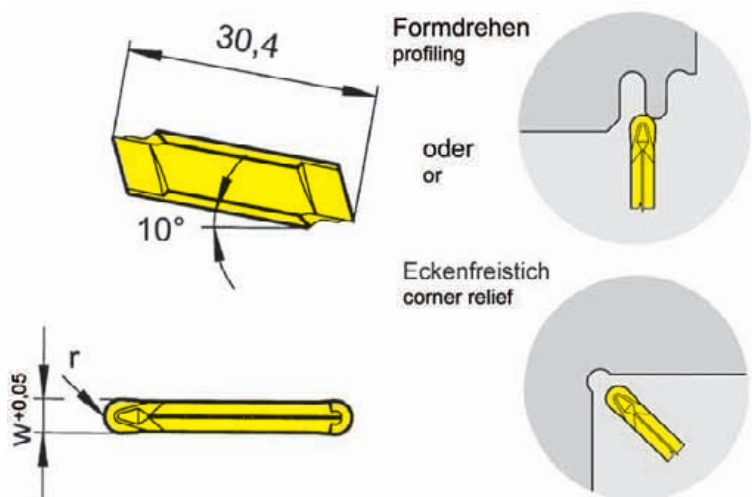

für Klemhalter
for Toolholder

- Typ 210
Type 213
214
218
219
225
226
257
R/LA210
R/LA226

Wechselgenauigkeit
Länge ± 0,025 mm
Indexability length ± 0,025 mm

H

Bestellnummer Part number	w	r	Größe Size	Spannbereich Clamping range	MG12	AS62	AS66	H20	P20	TN32
229.0015.30	3	1,5	225...04 ...03	3,0 - 5,0 3,0 - 4,0	▲	▲		▲	▲	▲
229.0020.40	4	2,0	225...04 ...03 ...04	3,0 - 5,0 3,0 - 4,0 4,0 - 5,0	▲	▲			▲	▲
229.0025.50	5	2,5	225...04 ...04	3,0 - 5,0 3,0 - 4,0	▲	Δ	Δ		▲	▲
229.0030.60	6	3,0	...05	5,1 - 6,0		Δ			▲	▲

▲ ab Lager / on stock Δ 4 Wochen / 4 weeks x auf Anfrage / upon request

● empfohlen / recommended

o bedingt einsetzbar / alternative recommendation

- nicht geeignet / not suitable

■ unbeschichtete HM-Sorten / uncoated grades

■ beschichtete HM-Sorten / coated grades

■ bestückt/Cermet / brazed/Cermet

Abmessungen in mm

Dimensions in mm

Wendeschneidplatten sind in rechten und linken Klemmaltern verwendbar.

Indexable inserts can be used in right and left hand toolholders.

P	o	●	●	●	●	●
M	●	-	o	o	-	-
K	●	-	●	-	-	-
N	●	-	●	-	-	-
S	●	-	o	-	-	-
H	-	-	-	-	-	-

HM-Sorten
Carbide grades

Gewindedrehen (außen) Vollprofil

Threading (external) Full profile



Wendeschneidplatte

Indexable insert

229

Metrisches ISO-Gewinde
Metric ISO thread

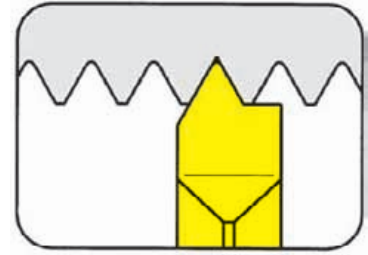

Steigung	Pitch	1-2,5 mm
----------	-------	----------

präzisionsgeschliffen
precision ground

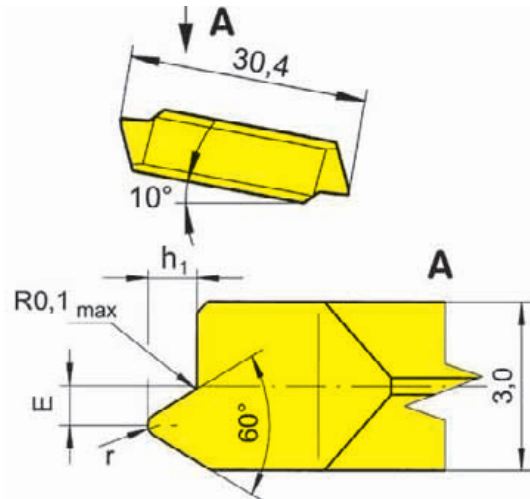

R = rechts wie gezeichnet
R = right hand version shown

L = links spiegelbildlich
L = left hand version

für Klemhalter
for Toolholder

- Typ 210
- Type 213
- 214
- 218
- 219
- 225
- 226
- 257
- R/LA210
- R/LA226

Wechselgenauigkeit
Länge ± 0,025 mm
Indexability length ± 0,025 mm

Bestellnummer Part number	P	E	r	h ₁	Größe Size	TN35
R/L229.0610.02	1,00	0,8	0,140	0,62	03/04	▲▲
R/L229.0712.02	1,25	0,8	0,175	0,78	03/04	▲▲
R/L229.0915.02	1,50	0,7	0,210	0,93	03/04	▲▲
R/L229.1017.02	1,75	0,5	0,250	1,08	03/04	▲▲
R/L229.1220.02	2,00	0,5	0,280	1,24	03/04	▲▲
R/L229.1525.02	2,50	0,3	0,360	1,54	03/04	▲/Δ

▲ ab Lager / on stock Δ 4 Wochen / 4 weeks x auf Anfrage / upon request

● empfohlen / recommended

o bedingt einsetzbar / alternative recommendation

- nicht geeignet / not suitable

■ unbeschichtete HM-Sorten / uncoated grades

■ beschichtete HM-Sorten / coated grades

■ bestückt/Cermet / brazed/Cermet

Abmessungen in mm

Dimensions in mm

Ausführung R oder L angeben

State R or L version

Keine Unterlegplatte erforderlich. Sämtliche HORN-Gewindeprofile sind mit einem **KEGELMANTEL-FREISCHLIFF** versehen.

No shims necessary. All HORN thread profiles are manufactured with **full ground radial clearance**.

P	•
M	•
K	•
N	•
S	•
H	-

HM-Sorten
Carbide grades

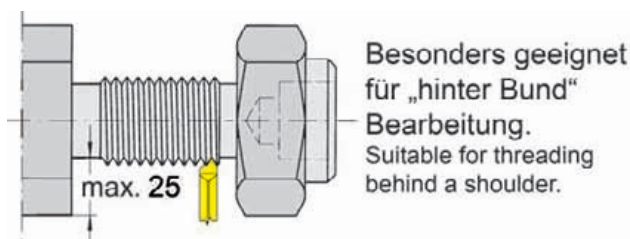

H

Gewindedrehen (außen) Teilprofil

Threading (external) Partial profile



Wendeschneidplatte

Indexable insert

229

Metrisches ISO-Gewinde
Metric ISO thread

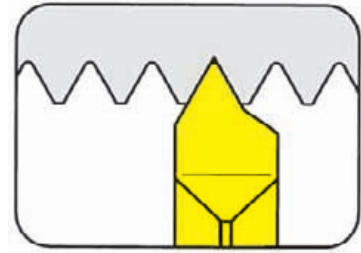

Steigung	Pitch	1-2,5 mm
----------	-------	----------

präzisionsgeschliffen
precision ground

für Klemhalter
for Toolholder

- Typ 210
Type 213
214
218
219
225
226
257
R/LA210
R/LA226

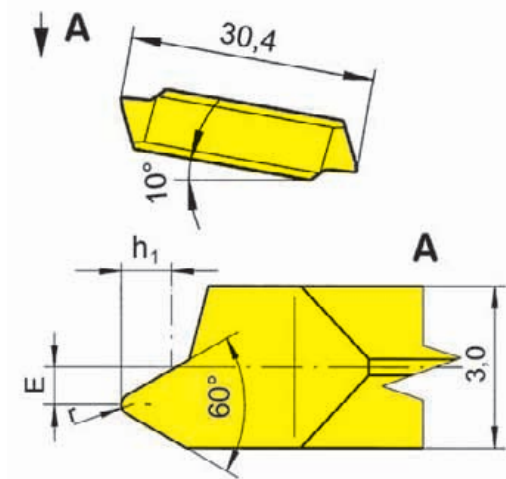

R = rechts wie gezeichnet
R = right hand version shown

L = links spiegelbildlich
L = left hand version

Wechselgenauigkeit
Länge $\pm 0,025$ mm
Indexability length $\pm 0,025$ mm

Bestellnummer Part number	P	E	r	h_1	Größe Size	TN35
R/L229.0610.01	1,00	0,8	0,12	0,61	03/04	▲/▲
R/L229.0712.01	1,25	0,8	0,15	0,77	03/04	▲/▲
R/L229.0915.01	1,50	0,7	0,20	0,92	03/04	▲/▲
R/L229.1017.01	1,75	0,5	0,25	1,07	03/04	▲/▲
R/L229.1220.01	2,00	0,5	0,25	1,23	03/04	▲/▲
R/L229.1525.01	2,50	0,3	0,35	1,53	03/04	▲/▲

▲ ab Lager / on stock Δ 4 Wochen / 4 weeks x auf Anfrage / upon request

● empfohlen / recommended

o bedingt einsetzbar / alternative recommendation

- nicht geeignet / not suitable

■ unbeschichtete HM-Sorten / uncoated grades

■ beschichtete HM-Sorten / coated grades

■ bestückt/Cermet / brazed/Cermet

P	•
M	•
K	•
N	•
S	•
H	-

Abmessungen in mm

Dimensions in mm

Ausführung R oder L angeben

State R or L version

Keine Unterlegplatte erforderlich. Sämtliche HORN-Gewindeprofile sind mit einem **KEGELMANTEL-FREISCHLIFF** versehen.

No shims necessary. All HORN thread profiles are manufactured with **full ground radial clearance**.

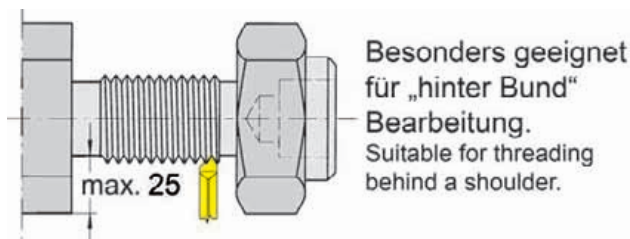

Gewindedrehen (außen) Vollprofil

Threading (external) Full profile



Wendeschneidplatte

Indexable insert

N229

Whitworth Rohrgewinde
Whitworth pipe thread

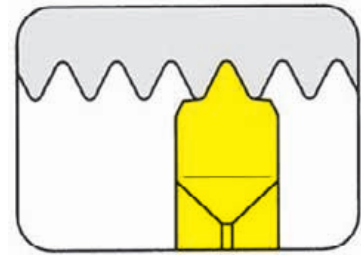

Gang pro Zoll	Threads per inch	28-11
---------------	------------------	-------

präzisionsgeschliffen
precision ground

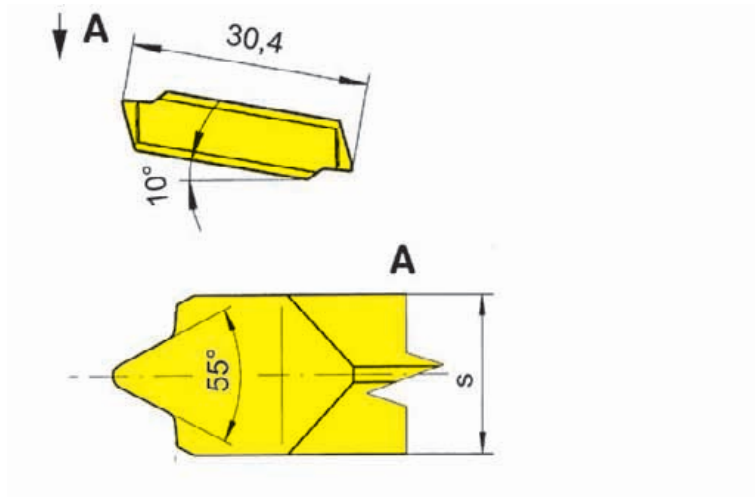

für Klemmhalter
for Toolholder

- Typ 210
- Type 213
- 214
- 218
- 219
- 225
- 226
- 257
- R/LA210
- R/LA226

Wechselgenauigkeit
Länge ± 0,025 mm
Indexability length ± 0,025 mm

Bestellnummer Part number	TPI	s	Größe Size	K10	MG12	TA45	TN35
N229.5511.02	11	3,5	03/04	Δ	Δ	Δ	▲
N229.5514.02	14	3,0	03/04	Δ	Δ	▲	▲
N229.5519.02	19	3,0	03/04		Δ	Δ	▲
N229.5528.02	28	3,0	03/04		Δ		▲

P	•	○	•	•
M	○	•	•	•
K	•	•	•	•
N	•	•	•	•
S	○	•	•	•
H	-	-	-	-

▲ ab Lager / on stock Δ 4 Wochen / 4 weeks x auf Anfrage / upon request

• empfohlen / recommended

○ bedingt einsetzbar / alternative recommendation

- nicht geeignet / not suitable

□ unbeschichtete HM-Sorten / uncoated grades

■ beschichtete HM-Sorten / coated grades

■ bestückt/Cermet / brazed/Cermet

Abmessungen in mm

Dimensions in mm

Keine Unterlegplatte erforderlich. Sämtliche HORN-Gewindeprofile sind mit einem **KEGELMANTEL-FREISCHLIFF** versehen.

No shims necessary. All HORN thread profiles are manufactured with **full ground radial clearance**.

Wendeschneidplatten sind in rechten und linken Klemmhaltern verwendbar.

Indexable inserts can be used in right and left hand toolholders.

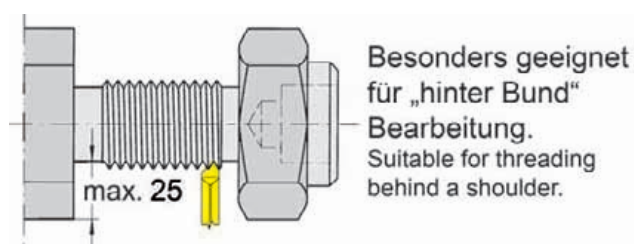

Abstechen

Parting Off



Wendeschneidplatte

Indexable insert

229/S229

mit Spanformrille
with chip former

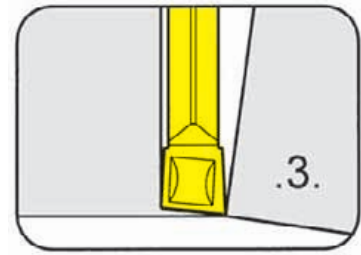

Stechtiefe bis Stechbreite	Depth of groove up to Width of groove	25 mm 3-4 mm
-------------------------------	--	-----------------

präzisionsgesintert
precision sintered

für Klemmhalter
for Toolholder

- Typ 210
Type 213
214
218
219
225
226
257
R/LA210
R/LA226

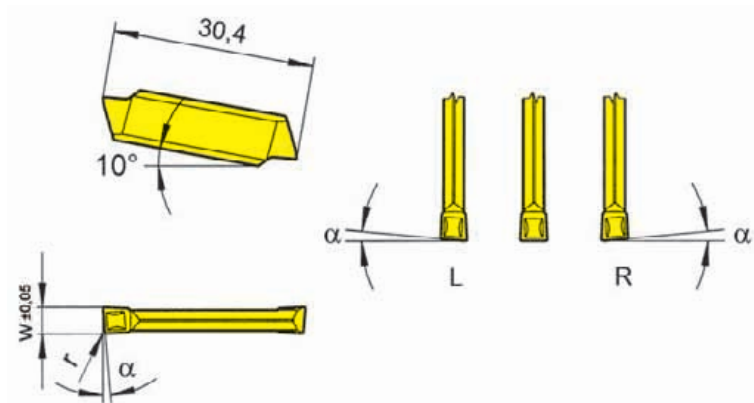

R = rechts wie gezeichnet
R = right hand version shown

L = links spiegelbildlich
L = left hand version

Wechselgenauigkeit
Länge ± 0,04 mm
Indexability length ± 0,04 mm

H

Bestellnummer Part number	w	r	α	Größe Size	MG12	AL96	AS62	AS66	H54	P20	TA45	TC92	TF45	TI22	TI25	TN32	TN35
R/L229.5300.31	3	0,2	5°	03	▲/▲		▲/▲					▲/Δ			▲/▲	▲/▲	▲/▲
R/LS229.0530.32	3	0,2	5°	03			▲/▲				Δ/Δ	Δ/Δ	▲/▲		▲/▲	▲/▲	▲/▲
S229.0300.32	3	0,2	0°	03	▲	▲	▲	▲	▲	Δ	Δ	▲	▲	Δ	▲	▲	▲
R/LS229.0540.32	4	0,2	5°	03/04			▲/Δ				Δ/Δ	Δ/Δ	▲/▲		▲/▲	Δ/▲	Δ/Δ
S229.0400.32	4	0,2	0°	03/04	Δ	▲	▲	▲	▲	Δ	Δ	▲	▲	Δ	▲	▲	▲
					P	○	●	●	●	●	●	●	●	●	●	●	●
					M	●	-	-	○	●	-	●	-	-	●	-	●
					K	●	●	-	●	-	●	-	●	-	●	-	●
					N	●	●	-	●	-	●	-	●	-	●	-	●
					S	●	-	-	○	-	●	-	●	-	●	-	●
					H	-	-	-	-	-	-	-	-	-	-	-	-

- ▲ ab Lager / on stock Δ 4 Wochen / 4 weeks x auf Anfrage / upon request
- empfohlen / recommended
- bedingt einsetzbar / alternative recommendation
- nicht geeignet / not suitable
- unbeschichtete HM-Sorten / uncoated grades
- beschichtete HM-Sorten / coated grades
- bestückt/Cermet / brazed/Cermet

Abmessungen in mm
Dimensions in mm

Ausführung R oder L angeben
State R or L version

Hinweis:

R/L229.5300.31 **präzisionsgeschliffen**, Längenmaß 30,0 mm

Note:

R/L229.5300.31 **precision ground**, length 30,0 mm

Wendeschneidplatten sind in rechten und linken Klemmhaltern verwendbar.
Indexable inserts can be used in right and left hand toolholders.

HM-Sorten
Carbide grades

Abstechen

Parting Off



Wendeschneidplatte

Indexable insert

S229

mit Spanformung
with chip forming

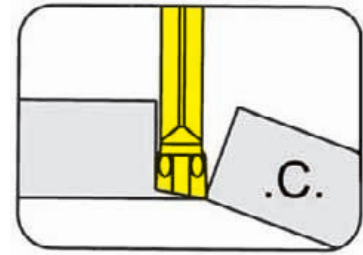

Stechtiefe bis Stechbreite	Depth of groove up to Width of groove	25 mm 3-4 mm
-------------------------------	--	-----------------

präzisionsgesintert
precision sintered

für Klemmhalter
for Toolholder

- Typ 210
Type 213
214
218
219
225
226
257
R/LA210
R/LA226

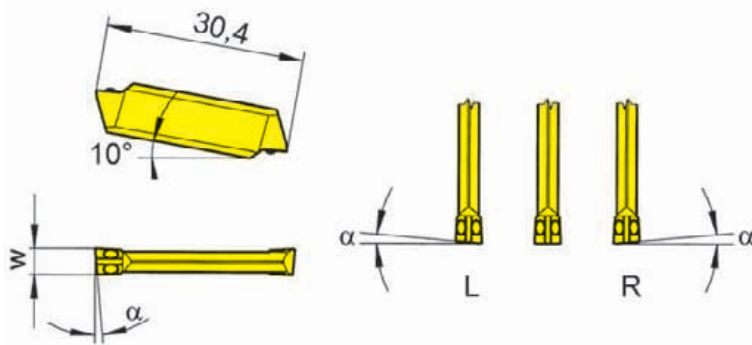

R = rechts wie gezeichnet
R = right hand version shown

L = links spiegelbildlich
L = left hand version

Wechselgenauigkeit
Länge $\pm 0,025$ mm
Indexability length $\pm 0,025$ mm

Bestellnummer Part number	w	α	Größe Size	TC92	TF45	Ti25	TN35
R/LS229.0530.C0	3	5°	03	Δ/Δ	▲/▲	Δ/Δ	▲/▲
R/LS229.0830.C0	3	8°	03	▲/▲	▲/▲	▲/▲	▲/▲
S229.0030.C0	3	0°	03	Δ	▲	▲	▲
R/LS229.0540.C0	4	5°	03/04	Δ/Δ	Δ/Δ	Δ/Δ	▲/Δ
R/LS229.0840.C0	4	8°	03/04	Δ/Δ	Δ/Δ	▲/Δ	▲/Δ
S229.0040.C0	4	0°	03/04	Δ	Δ	▲	▲
				P	•	•	•
				M	-	•	•
				K	-	•	•
				N	-	•	•
				S	-	•	•
				H	-	-	-

▲ ab Lager / on stock Δ 4 Wochen / 4 weeks x auf Anfrage / upon request

● empfohlen / recommended

o bedingt einsetzbar / alternative recommendation

- nicht geeignet / not suitable

□ unbeschichtete HM-Sorten / uncoated grades

■ beschichtete HM-Sorten / coated grades

■ bestückt/Cermet / brazed/Cermet

Abmessungen in mm

Dimensions in mm

Ausführung R oder L angeben

State R or L version

Wendeschneidplatten sind in rechten und linken Klemmhaltern verwendbar.

Indexable inserts can be used in right and left hand toolholders.

HM-Sorten
Carbide grades



Abstechen

Parting Off



Wendeschneidplatte

Indexable insert

S229

mit Spanformung
with chip forming

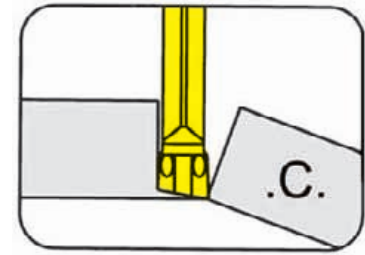

Stechtiefe bis
Stechbreite

Depth of groove up to
Width of groove

25 mm
3-4 mm

präzisionsgesintert
precision sintered

für Klemmhalter
for Toolholder

Typ 210
Type 213
214
218
219
225
226
257
R/LA210
R/LA226

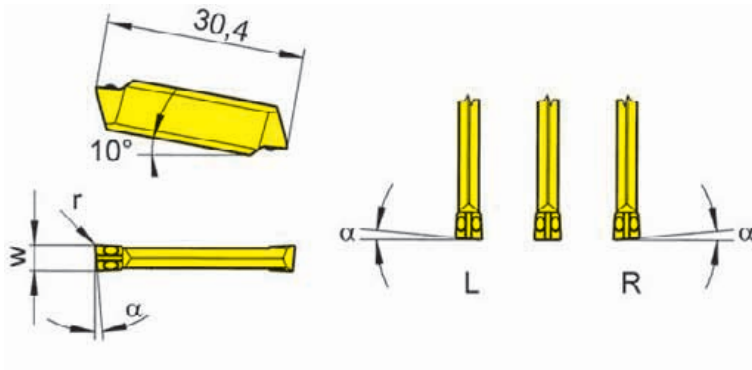

R = rechts wie gezeichnet
R = right hand version shown

L = links spiegelbildlich
L = left hand version

Wechselgenauigkeit
Länge $\pm 0,025$ mm
Indexability length $\pm 0,025$ mm

Bestellnummer Part number	w	r	α	Größe Size	TC92	TF45	TI25	TN35
R/LS229.0530.C1	3	0,15	5°	03	Δ/Δ	Δ/Δ	▲/Δ	▲/▲
R/LS229.0830.C1	3	0,15	8°	03	Δ/Δ	▲/▲	▲/Δ	▲/▲
S229.0030.C1	3	0,15	0°	03	Δ	▲	▲	▲
R/LS229.0540.C1	4	0,15	5°	03/04	Δ/Δ	Δ/Δ	Δ/Δ	Δ/Δ
R/LS229.0540.C1	4	0,15	5°	03/04	Δ/Δ	Δ/Δ	Δ/Δ	Δ/Δ
R/LS229.0840.C1	4	0,15	8°	03/04	Δ/Δ	Δ/Δ	Δ/Δ	▲/Δ
S229.0040.C1	4	0,15	0°	03/04	Δ	Δ	Δ	Δ

▲ ab Lager / on stock Δ 4 Wochen / 4 weeks x auf Anfrage / upon request

● empfohlen / recommended

o bedingt einsetzbar / alternative recommendation

- nicht geeignet / not suitable

■ unbeschichtete HM-Sorten / uncoated grades

■ beschichtete HM-Sorten / coated grades

■ bestückt/Cermet / brazed/Cermet

Abmessungen in mm

Dimensions in mm

Ausführung R oder L angeben

State R or L version

Wendeschneidplatten sind in rechten und linken Klemmhaltern verwendbar.

Indexable inserts can be used in right and left hand toolholders.

P	●	●	●	●
M	-	●	●	●
K	-	●	●	●
N	-	●	●	●
S	-	●	●	●
H	-	-	-	-

HM-Sorten
Carbide grades

H

Einstechen und Abstechen

Grooving and Parting Off



Klemmhalter

Toolholder

H259

Messingbearbeitung
Machining brass

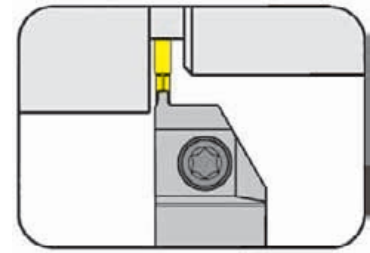

Stechtiefe bis Stechbreite	Depth of groove up to Width of groove	18 mm 3 - 4 mm
-------------------------------	--	-------------------

für Wendeschneidplatte
for Indexable insert

Typ 259
Type

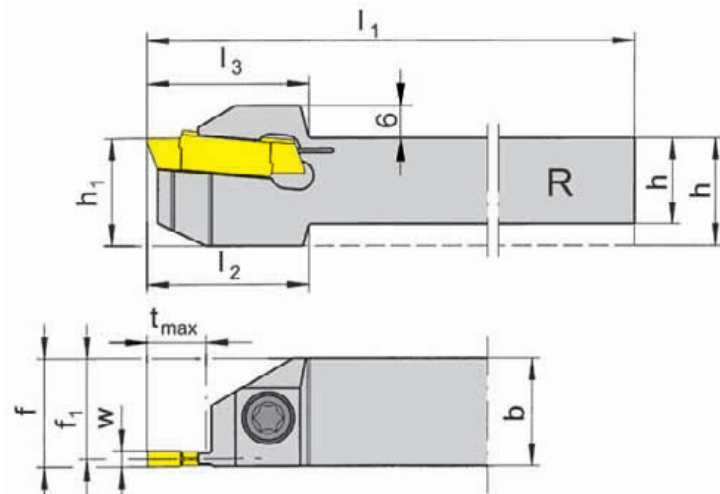

R = rechts wie gezeichnet
R = right hand version shown

L = links spiegelbildlich
L = left hand version

Bestellnummer Part number	h	b	l ₁	l ₂	l ₃	h ₁	f	f ₁	t _{max}	Größe Size
R/LH259.1616.03	16	16	135	30	30	20	f ₁ +w/2	14,55	11	03
R/LH259.2020.03	20	20	135	-	30	20	f ₁ +w/2	18,55	11	03
R/LH259.2525.03	25	25	135	-	30	25	f ₁ +w/2	23,55	11	03
R/LH259.1616.13	16	16	135	33	33	20	f ₁ +w/2	14,55	18	03
R/LH259.2020.13	20	20	135	-	33	20	f ₁ +w/2	18,55	18	03
R/LH259.2525.13	25	25	135	-	33	25	f ₁ +w/2	23,55	18	03

Ausführung R oder L angeben
State R or L version

w siehe WSP
w see indexable inserts

Abmessungen in mm
Dimensions in mm

Weitere Abmessungen auf Anfrage
Further sizes upon request

Das Anzugsdrehmoment der Schrauben finden Sie in den Technischen Hinweisen.
For torque specification of the screw, please see Technical Instructions.

Ersatzteile

Spare Parts

Klemmhalter Toolholder	Spannschraube Screw	TORX PLUS®-Schlüssel TORX PLUS® Wrench
R/LH259...	6.23T25P	T25PQ

Einstechen und Abstechen

Grooving and Parting Off



Wendeschneidplatte

Indexable insert

259

Messingbearbeitung
Machining brass

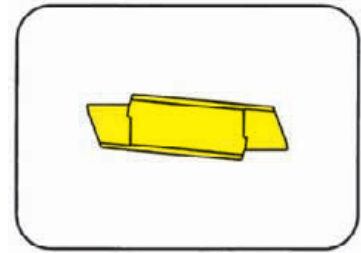

Stechtiefe bis Stechbreite	Depth of groove up to Width of groove	18 mm 3-4 mm
-------------------------------	--	-----------------

präzisionsgeschliffen
precision ground

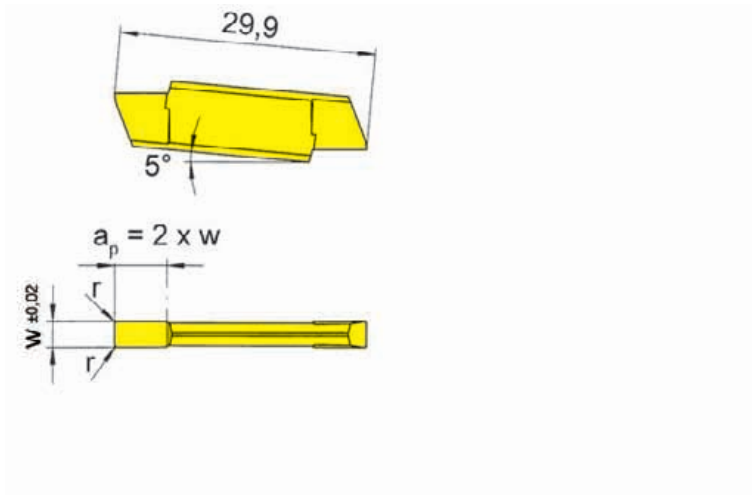

für Klemmhalter
for Toolholder

Typ H259
Type

Wechselgenauigkeit
Länge ± 0,015 mm
Indexability length ± 0,015 mm

Nutzbare Nebeschneidenlänge a_p
Usable length of minor cutting edge a_p

2 x w zur Messingbearbeitung (Ms58)
2 x w for machining brass (Ms58)

Bestellnummer Part number	w	r	Größe Size	MG12
259.0300.M1	3	0,15	03	Δ
259.0300.M2	3	0,20	03	▲
259.0400.M1	4	0,15	03	Δ
259.0400.M2	4	0,20	03	▲

▲ ab Lager / on stock Δ 4 Wochen / 4 weeks x auf Anfrage / upon request

● empfohlen / recommended

○ bedingt einsetzbar / alternative recommendation

- nicht geeignet / not suitable

□ unbeschichtete HM-Sorten / uncoated grades

■ beschichtete HM-Sorten / coated grades

■ bestückt/Cermet / brazed/Cermet

Abmessungen in mm

Dimensions in mm

Wendeschneidplatten sind in rechten und linken Klemmhaltern verwendbar.

Indexable inserts can be used in right and left hand toolholders.

P	○
M	●
K	●
N	●
S	●
H	-

HM-Sorten
Carbide grades

H

231



**Klemmhalter mit
Schneidplatten**

Stechbreite 2,5 - 10,0 mm

**Toolholder with
Inserts**

width of groove 2,5 - 10,0 mm



Einstecken (außen)

Grooving (external)

Klemmhalter
Toolholder
211/221/228

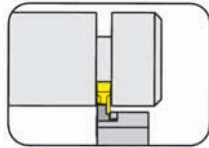

Seite/Page
I3-I4

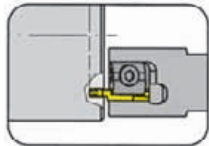

Seite/Page
I11-I12

Kurzklammhalter
Cartridge
208

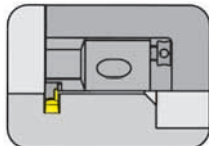

Seite/Page
I5

Wendeschneidplatte
Indexable insert
231

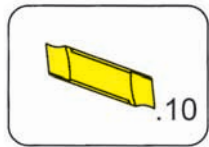

Seite/Page
I7-I8

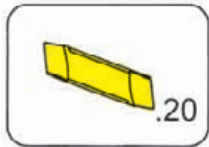

Seite/Page
I9-I10

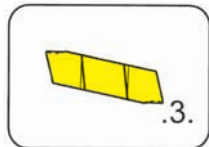

Seite/Page
I13

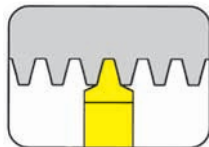

Seite/Page
I14

Einstecken (außen)

Grooving (external)



Klemmhalter

Toolholder

211

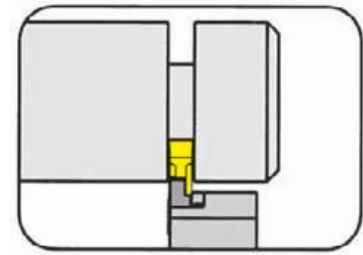

Stechtiefe bis
Spannbereich

Depth of groove up to
Clamping range

11 mm
2,5 - 5,0 mm

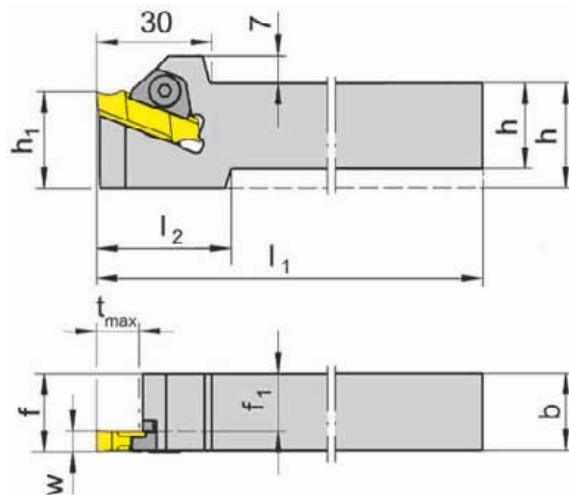

für Wendeschneidplatte
for Indexable insert

Typ 231
Type N231

R = rechts wie gezeichnet
R = right hand version shown

L = links spiegelbildlich
L = left hand version

Bestellnummer Part number	h	b	l ₁	l ₂	h ₁	f ₁	f	t _{max}	Größe Size	Spannbereich Clamping range
R/L211.2020.02	20	20	125	35	25	17,5	f ₁ +w-a ₁	11	02	2,5-3,0
R/L211.2525.02	25	25	150	-	25	22,5	f ₁ +w-a ₁	11	02	2,5-3,0
R/L211.3232.02	32	32	170	-	32	29,5	f ₁ +w-a ₁	11	02	2,5-3,0
R/L211.2020.03	20	20	125	35	25	17,0	f ₁ +w-a ₁	11	03	3,0-4,0
R/L211.2525.03	25	25	150	-	25	22,0	f ₁ +w-a ₁	11	03	3,0-4,0
R/L211.3232.03	32	32	170	-	32	29,0	f ₁ +w-a ₁	11	03	3,0-4,0
R/L211.2020.04	20	20	125	35	25	16,0	f ₁ +w-a ₁	11	04	4,0-5,0
R/L211.2525.04	25	25	150	-	25	21,0	f ₁ +w-a ₁	11	04	4,0-5,0
R/L211.3232.04	32	32	170	-	32	28,0	f ₁ +w-a ₁	11	04	4,0-5,0

Ausführung R oder L angeben
State R or L version

w, a₁ siehe WSP
w, a₁ see indexable inserts

Abmessungen in mm
Dimensions in mm

Weitere Abmessungen auf Anfrage
Further sizes upon request

Das Anzugsdrehmoment der Schrauben finden Sie in den Technischen Hinweisen.
For torque specification of the screw, please see Technical Instructions.

Ersatzteile

Spare Parts

Klemmhalter Toolholder	Inbus-Schlüssel Wrench	Spannelement Clamping element
R/L211...02	SW3,0 DIN911	2.16.2
R/L211...03	SW3,0 DIN911	2.16.3
R/L211...04	SW3,0 DIN911	2.16.7

Einstecken (außen)

Grooving (external)



Klemmhalter

Toolholder

211

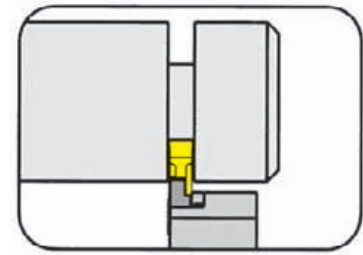

Stechtiefe bis Spannbereich	Depth of groove up to Clamping range	11 mm 5,0 - 10,0 mm
--------------------------------	---	------------------------

für Wendeschneidplatte
for Indexable insert

Typ 231
Type N231

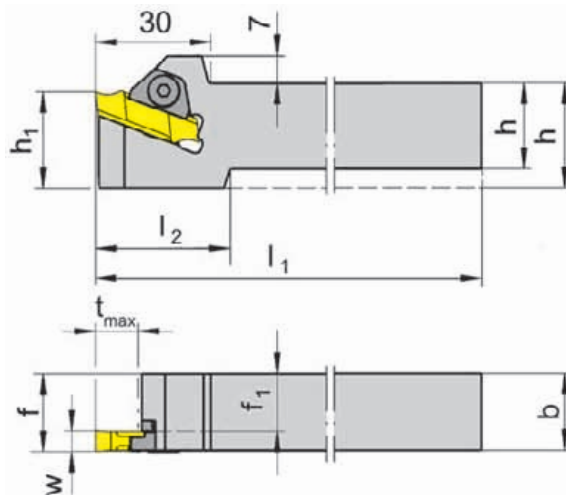

R = rechts wie gezeichnet
R = right hand version shown

L = links spiegelbildlich
L = left hand version

Bestellnummer Part number	h	b	l ₁	l ₂	h ₁	f ₁	f	t _{max}	Größe Size	Spannbereich Clamping range
R/L211.2020.05	20	20	125	35	25	15	f ₁ +w-a ₁	11	05	5,0-6,5
R/L211.2525.05	25	25	150	-	25	20	f ₁ +w-a ₁	11	05	5,0-6,5
R/L211.3232.05	32	32	170	-	32	27	f ₁ +w-a ₁	11	05	5,0-6,5
R/L211.2020.07	20	20	125	35	25	13	f ₁ +w-a ₁	11	07	6,5-8,5
R/L211.2525.07	25	25	150	-	25	18	f ₁ +w-a ₁	11	07	6,5-8,5
R/L211.3232.07	32	32	170	-	32	25	f ₁ +w-a ₁	11	07	6,5-8,5
R/L211.2020.09	20	20	125	35	25	11	f ₁ +w-a ₁	11	09	8,5-10,0
R/L211.2525.09	25	25	150	-	25	16	f ₁ +w-a ₁	11	09	8,5-10,0
R/L211.3232.09	32	32	170	-	32	23	f ₁ +w-a ₁	11	09	8,5-10,0

Ausführung R oder L angeben
State R or L version

w, a₁ siehe WSP
w, a₁ see indexable inserts

Abmessungen in mm
Dimensions in mm

Weitere Abmessungen auf Anfrage
Further sizes upon request

Das Anzugsdrehmoment der Schrauben finden Sie in den Technischen Hinweisen.
For torque specification of the screw, please see Technical Instructions.

Ersatzteile

Spare Parts

Klemmhalter Toolholder	Inbus-Schlüssel Wrench	Spannelement Clamping element
R/L211...	SW3,0 DIN911	2.16.7

Einstecken (innen)

Grooving (internal)



Kurzklemmhalter

208

Cartridge

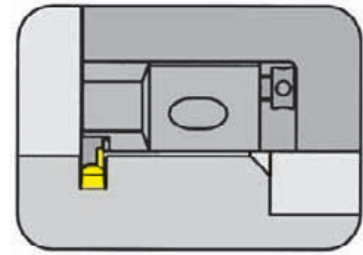

Bohrungs-Ø ab
Spannbereich

Bore Ø from
Clamping range

75 mm
4,0 - 10,0 mm

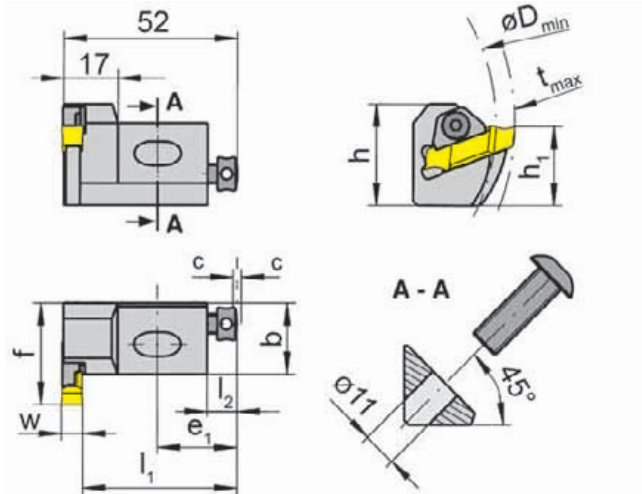

R = rechts wie gezeichnet
R = right hand version shown

L = links spiegelbildlich
L = left hand version

für Wendeschneidplatte
for Indexable insert

Typ 231
Type N231

Stechtiefe in Abhängigkeit des Bohrungs-Ø
Depth of groove in relation to bore Ø

D_{min}	t_{max}
75	5,0
85	6,0
95	6,5
110	7,0
140	8,0
200	9,0

Bestellnummer Part number	h	b	h_1	f	l_1	e_1	l_2	c	D_{min}	t_{max}	Größe Size	Spannbereich Clamping range
R/L208.2520.04	32	20	25	32	47,8	25	9	2	75	5	04	4,0-5,0
R/L208.2520.05	32	20	25	32	46,8	25	9	2	75	5	05	5,0-6,5
R/L208.2520.07	32	20	25	32	44,8	25	9	2	75	5	07	6,5-8,5
R/L208.2520.09	32	20	25	32	42,8	25	9	2	75	5	09	8,5-10,0

Ausführung R oder L angeben
State R or L version

Weitere Abmessungen auf Anfrage
Further sizes upon request

Das Anzugsdrehmoment der Schrauben finden Sie in den Technischen Hinweisen.
For torque specification of the screw, please see Technical Instructions.

Abmessungen in mm
Dimensions in mm

Ersatzteile

Spare Parts

Kurzklemmhalter Cartridge	Spannschraube Screw	Inbus-Schlüssel Wrench	Spannelement Clamping element
R/L208...	4.08.913	SW3,0 DIN911	2.16.7 K

Einstecken (außen)

Grooving (external)



Einbaumaß Kurzklemmhalter

Seating Dimensions Cartridge

208

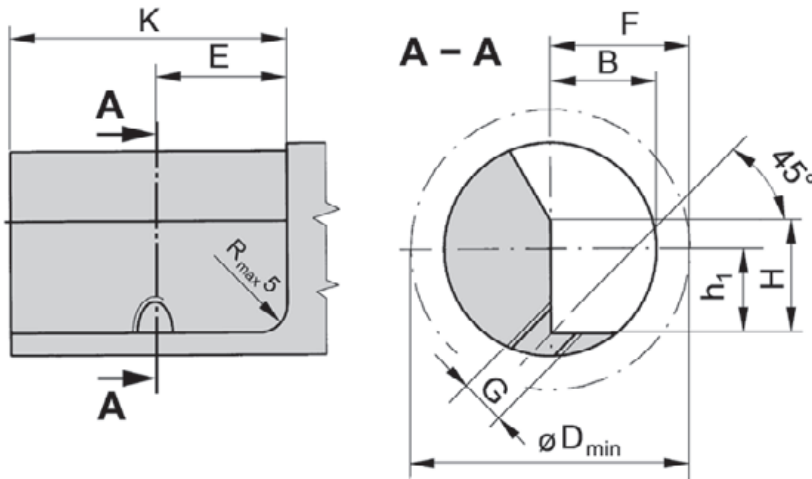
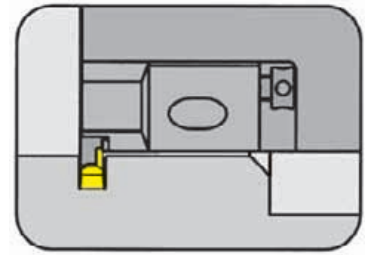

Kurzklemmhalter Cartridge	F	G	H	K	E	B	h ₁	D _{min}	Befestigungsschraube Fastening Screw
R/L208.2520...	32	M10	32	50	25	20	25	75	0.30.208

Abmessungen in mm
Dimensions in mm

Einstecken (außen)

Grooving (external)



Wendeschneidplatte

Indexable insert

231

mit runder Spanleitstufe
with round chip breaker

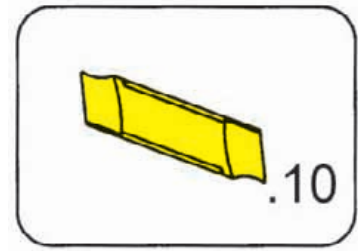

Stechtiefe bis Stechbreite	Depth of groove up to Width of groove	11 mm 2,5-3,5 mm
-------------------------------	--	---------------------

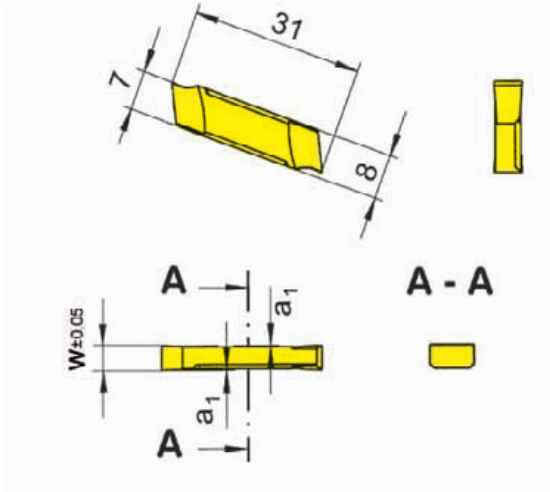

R = rechts wie gezeichnet
R = right hand version shown

L = links spiegelbildlich
L = left hand version

für Klemmhalter
for Toolholder

Typ 208
Type 211

Wechselgenauigkeit
Länge ± 0,025 mm
Indexability length ± 0,025 mm

Bestellnummer Part number	w	a ₁	Größe Size	K10	P20	TN32
R/L231.0250.10	2,5	0,2	02	Δ/Δ	▲/▲	▲/▲
R/L231.0300.10	3,0	0,2	03		Δ/Δ	
R/L231.0350.10	3,5	0,2	03	Δ/Δ	Δ/Δ	Δ/Δ

P	•	•	•
M	o	-	-
K	•	-	-
N	•	-	-
S	o	-	-
H	-	-	-

- ▲ ab Lager / on stock Δ 4 Wochen / 4 weeks x auf Anfrage / upon request
- empfohlen / recommended
- o bedingt einsetzbar / alternative recommendation
- nicht geeignet / not suitable
- unbeschichtete HM-Sorten / uncoated grades
- beschichtete HM-Sorten / coated grades
- bestückt/Cermet / brazed/Cermet

Abmessungen in mm
Dimensions in mm

Ausführung R oder L angeben
State R or L version

Rechte WSP in rechten, linke WSP in linken Klemmhaltern verwenden.
Use right hand inserts in right hand toolholders and left hand inserts in left hand toolholders

HM-Sorten
Carbide grades

Einstechen (außen und innen)

Grooving (external and internal)



Wendeschneidplatte

Indexable insert

231

mit runder Spanleitstufe
with round chip breaker

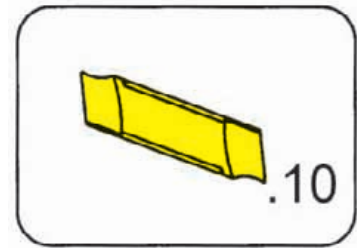

Stechtiefe bis
Stechbreite

Depth of groove up to
Width of groove

11 mm
4-10 mm

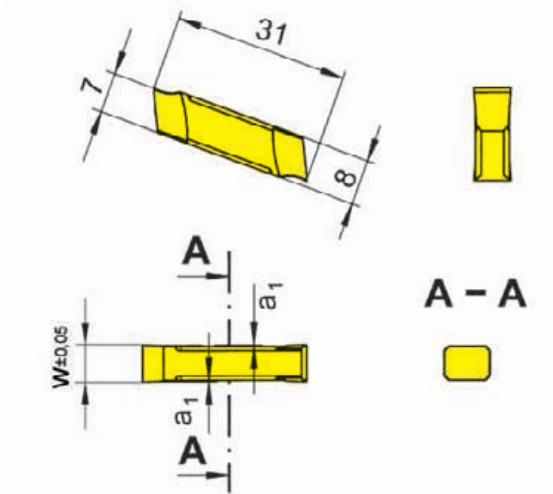

für Klemmhalter
for Toolholder

Typ 211
Type 208

Wechselgenauigkeit
Länge ± 0,025 mm
Indexability length ± 0,025 mm

Bestellnummer Part number	w	a ₁	Größe Size	K10	P20	TC92	TN32
231.0400.10	4	0,2	04	▲	▲	▲	▲
231.0500.10	5	0,2	05		▲	▲	
231.0600.10	6	0,2	05	▲	▲	▲	
231.0700.10	7	0,2	07		▲	▲	▲
231.0800.10	8	0,2	07	▲	▲		▲
231.0900.10	9	0,2	09	▲	▲		
231.1000.10	10	0,2	09	▲	▲	▲	▲

▲ ab Lager / on stock Δ 4 Wochen / 4 weeks x auf Anfrage / upon request

● empfohlen / recommended

o bedingt einsetzbar / alternative recommendation

- nicht geeignet / not suitable

■ unbeschichtete HM-Sorten / uncoated grades

■ beschichtete HM-Sorten / coated grades

■ bestückt/Cermet / brazed/Cermet

Abmessungen in mm

Dimensions in mm

Wendeschneidplatten sind in rechten und linken Klemmhaltern verwendbar.

Indexable inserts can be used in right and left hand toolholders.

P	●	●	●	●
M	o	-	-	-
K	●	-	-	-
N	●	-	-	-
S	o	-	-	-
H	-	-	-	-

HM-Sorten
Carbide grades

Einstecken (außen)

Grooving (external)



Wendeschneidplatte

Indexable insert

231

mit gerader Spanleitstufe
with round chip breaker

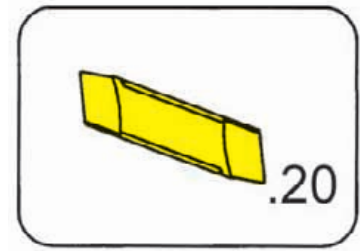

Stechtiefe bis Stechbreite	Depth of groove up to Width of groove	11 mm 2,5-3,5 mm
-------------------------------	--	---------------------

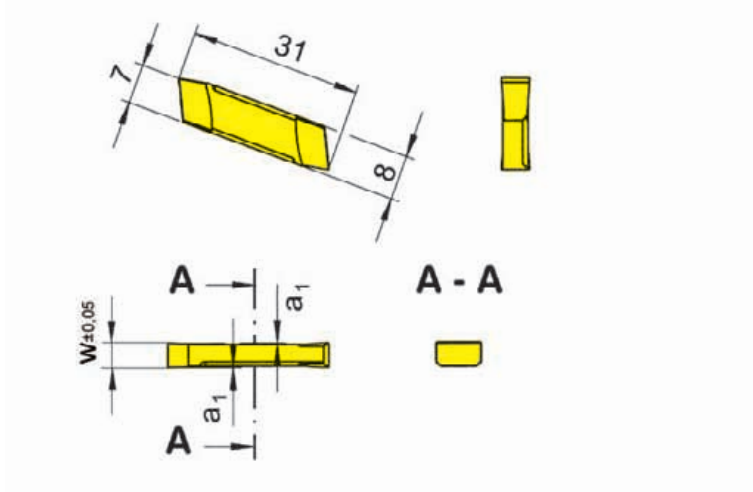

R = rechts wie gezeichnet
R = right hand version shown

L = links spiegelbildlich
L = left hand version

für Klemmhalter
for Toolholder

Typ 208
Type 211

Wechselgenauigkeit
Länge ± 0,025 mm
Indexability length ± 0,025 mm

Bestellnummer Part number	w	a ₁	Größe Size	TC92
R/L231.0250.20	2,5	0,2	02	ΔΔ
R/L231.0300.20	3,0	0,2	03	ΔΔ
R/L231.0350.20	3,5	0,2	03	ΔΔ

▲ ab Lager / on stock Δ 4 Wochen / 4 weeks x auf Anfrage / upon request

● empfohlen / recommended

o bedingt einsetzbar / alternative recommendation

- nicht geeignet / not suitable

■ unbeschichtete HM-Sorten / uncoated grades

■ beschichtete HM-Sorten / coated grades

■ bestückt/Cermet / brazed/Cermet

Abmessungen in mm

Dimensions in mm

Ausführung R oder L angeben

State R or L version

Rechte WSP in rechten, linke WSP in linken Klemmhaltern verwenden.

Use right hand inserts in right hand toolholders and left hand inserts in left hand toolholders

P	●
M	-
K	-
N	-
S	-
H	-

HM-Sorten
Carbide grades

Einstecken (außen und innen)

Grooving (external and internal)



Wendeschneidplatte

Indexable insert

231

mit gerader Spanleitstufe
with round chip breaker

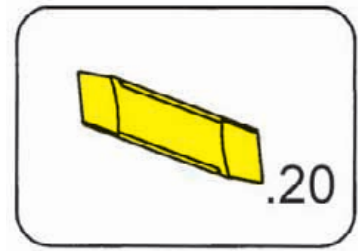

Stechtiefe bis
Stechbreite

Depth of groove up to
Width of groove

11 mm
4-10 mm

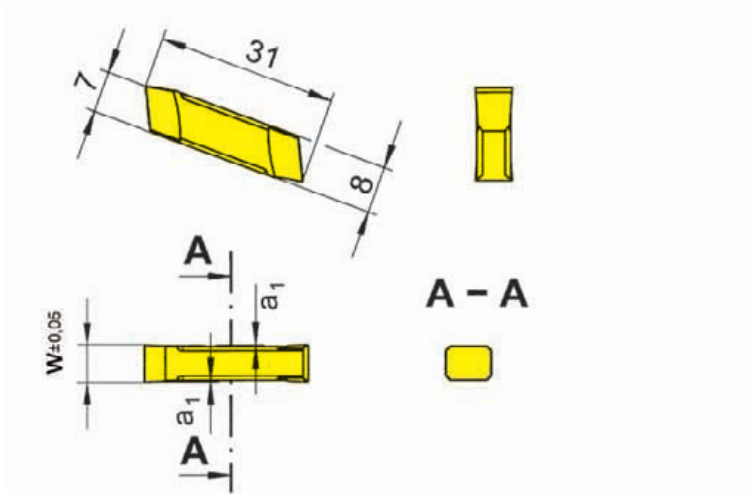

für Klemmhalter
for Toolholder

Typ 208
Type 211

Wechselgenauigkeit
Länge ± 0,025 mm
Indexability length ± 0,025 mm

Bestellnummer Part number	w	a ₁	Größe Size	HM-Sorten			
				K10	AS46	TC92	TF45
231.0400.20	4	0,2	04			Δ	x
231.0500.20	5	0,2	05			Δ	x
231.0600.20	6	0,2	05			Δ	x
231.0700.20	7	0,2	07			Δ	x
231.0800.20	8	0,2	07			Δ	x
231.0900.20	9	0,2	09			Δ	x
231.1000.20	10	0,2	09	Δ	Δ	Δ	x

▲ ab Lager / on stock Δ 4 Wochen / 4 weeks x auf Anfrage / upon request

● empfohlen / recommended

o bedingt einsetzbar / alternative recommendation

- nicht geeignet / not suitable

■ unbeschichtete HM-Sorten / uncoated grades

■ beschichtete HM-Sorten / coated grades

■ bestückt/Cermet / brazed/Cermet

Abmessungen in mm

Dimensions in mm

Ausführung R oder L angeben

State R or L version

Wendeschneidplatten sind in rechten und linken Klemmhaltern verwendbar.

Indexable inserts can be used in right and left hand toolholders.

P	●	●	●	●
M	o	●	-	●
K	●	●	-	●
N	●	●	-	●
S	o	●	-	●
H	-	-	-	-

HM-Sorten
Carbide grades

Axialeinstechen

Face Grooving



Klemmhalter

Toolholder

221

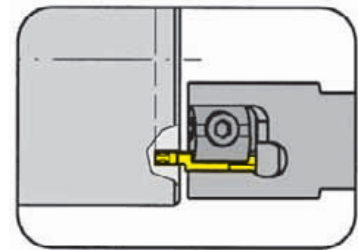

Nutaußen-Ø ab	from outer groove Ø	40 mm
Stechtiefe bis	Depth of groove up to	8 mm
Spannbereich	Clamping range	3,0 - 10,0 mm

für Wendeschneidplatte
for Indexable insert

Typ 231
Type N231

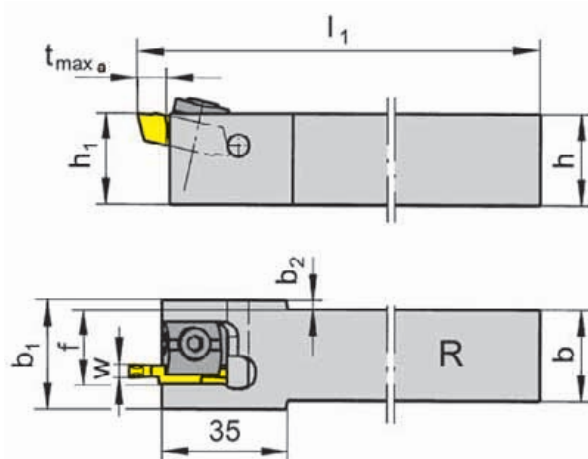

R = rechts wie gezeichnet
R = right hand version shown

L = links spiegelbildlich
L = left hand version

Bestellnummer Part number	h	b	l ₁	h ₁	t _{max a}	f	b ₁	b ₂	D _{a min}	Größe Size	Spannbereich Clamping range
R/L221.2020.04	20	20	125	20	8	17,9	28	4,0	40	04	3,0-4,0
R/L221.2525.04	25	25	150	25	8	20,4	28	1,5	40	04	3,0-4,0
R/L221.2020.05	20	20	125	20	8	18,9	30	5,0	40	05	4,1-6,0
R/L221.2525.05	25	25	150	25	8	21,4	30	2,5	40	05	4,1-6,0
R/L221.2020.07	20	20	125	20	8	19,9	32	6,0	40	07	6,1-8,0
R/L221.2525.07	25	25	150	25	8	22,4	32	3,5	40	07	6,1-8,0
R/L221.2020.09	20	20	125	20	8	20,9	34	7,0	40	09	8,1-10,0
R/L221.2525.09	25	25	150	25	8	23,4	34	4,5	40	09	8,1-10,0

Ausführung R oder L angeben
State R or L version

w siehe WSP
w see indexable inserts

Abmessungen in mm
Dimensions in mm

Weitere Abmessungen auf Anfrage
Further sizes upon request

Dieser Klemmhalter ist in Abhängigkeit der Stechtiefe von D_a = 30 mm bis ∞ einsetzbar.
This toolholder can be used from D_a = 30 mm up to ∞ depending on grooving depth.

Das Anzugsdrehmoment der Schrauben finden Sie in den Technischen Hinweisen.
For torque specification of the screw, please see Technical Instructions.

Ersatzteile

Spare Parts

Klemmhalter Toolholder	Anschlagstift Stop Pin	Spannelement Clamping element	TORX PLUS®-Schlüssel TORX PLUS® Wrench
R/L221...	3.6.28	01.60.12	T20PQ

Axialeinstechen

Face Grooving



Klemmhalter

Toolholder

228

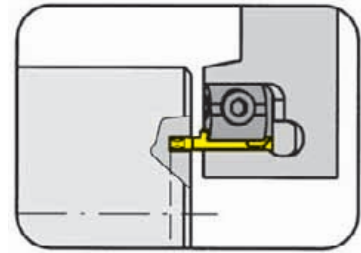

Nutaußen-Ø ab	from outer groove Ø	40 mm
Stechtiefe bis	Depth of groove up to	8 mm
Spannbereich	Clamping range	3,0 - 10,0 mm

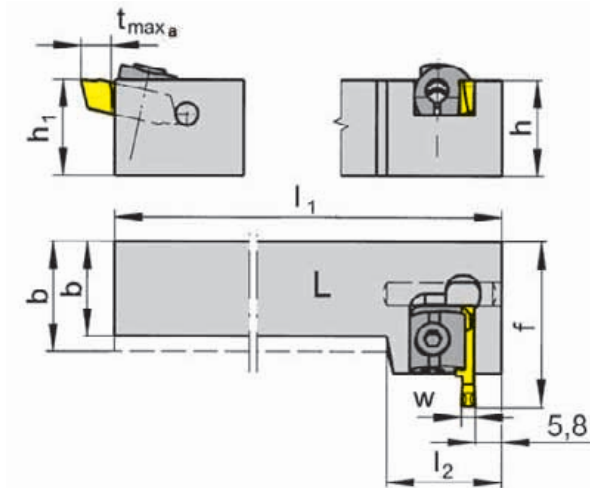

für Wendeschneidplatte
for Indexable insert

Typ 231
Type N231

Stechtiefe in Abhängigkeit des Bohrungs-Ø
Depth of groove in relation to bore Ø

D _{min}	t _{max}
75	5,0
85	6,0
95	6,5
110	7,0
140	8,0
200	9,0

L = links wie gezeichnet
L = left hand version shown

R = rechts spiegelbildlich
R = right hand version

Bestellnummer Part number	h	b	h ₁	t _{max a}	f	D _{a min}	l ₁	l ₂	Größe Size	Spannbereich Clamping range
R/L228.2020.04	20	20	20	8	38,5	40	125	35,5	04	3,0-4,0
R/L228.2525.04	25	25	25	8	38,5	40	150	35,5	04	3,0-4,0
R/L228.2020.05	20	20	20	8	38,5	40	125	35,5	05	4,1-6,0
R/L228.2525.05	25	25	25	8	38,5	40	150	35,5	05	4,1-6,0
R/L228.2020.07	20	20	20	8	38,5	40	125	35,5	07	6,1-8,0
R/L228.2525.07	25	25	25	8	38,5	40	150	35,5	07	6,1-8,0
R/L228.2020.09	20	20	20	8	38,5	40	125	35,5	09	8,1-10,0
R/L228.2525.09	25	25	25	8	38,5	40	150	35,5	09	8,1-10,0

Ausführung R oder L angeben
State R or L version

w siehe WSP
w see indexable inserts

Abmessungen in mm
Dimensions in mm

Weitere Abmessungen auf Anfrage
Further sizes upon request

Dieser Klemmhalter ist in Abhängigkeit der Stechtiefe von D_a = 30 mm bis ∞ einsetzbar.
This toolholder can be used from D_a = 30 mm up to ∞ depending on grooving depth.

Das Anzugsdrehmoment der Schrauben finden Sie in den Technischen Hinweisen.
For torque specification of the screw, please see Technical Instructions.

Ersatzteile

Spare Parts

Klemmhalter Toolholder	Anschlagstift Stop Pin	Spannelement Clamping element	TORX PLUS®-Schlüssel TORX PLUS® Wrench
R/L228...	3.6.28	01.60.12	T20PQ

Axialeinstechen

Face Grooving



Wendeschneidplatte

Indexable insert

231/N231

mit Spanformrille
with chip former

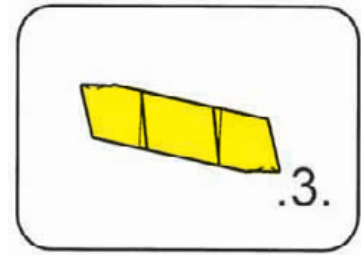

Nutaußen-Ø ab
Stechtiefe bis
Stechbreite

from outer groove Ø
Depth of groove up to
Width of groove

40 mm
8 mm
3-10 mm

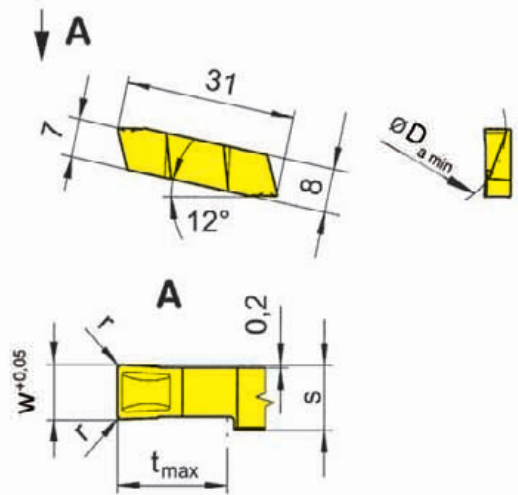

für Klemhalter
for Toolholder

Typ 221
Type 228

Wechselgenauigkeit
Länge $\pm 0,025$ mm
Indexability length $\pm 0,025$ mm

Bestellnummer Part number	w	r	t _{max}	s	D _{a min}	Größe Size	TN35
R/L231.4030.32	3	0,2	8	3,8	40	04	▲▲
R/L231.4040.32	4	0,2	8	3,8	40	04	▲▲
R/L231.4050.34	5	0,4	8	5,8	40	05	▲▲
N231.4060.34	6	0,4	8	5,8	40	05	▲
N231.4070.36	7	0,6	8	7,8	40	07	▲
N231.4080.36	8	0,6	8	7,8	40	07	▲
N231.4090.38	9	0,8	8	9,8	40	09	▲
N231.4100.38	10	0,8	8	9,8	40	09	▲

▲ ab Lager / on stock Δ 4 Wochen / 4 weeks x auf Anfrage / upon request

● empfohlen / recommended

o bedingt einsetzbar / alternative recommendation

- nicht geeignet / not suitable

■ unbeschichtete HM-Sorten / uncoated grades

■ beschichtete HM-Sorten / coated grades

■ bestückt/Cermet / brazed/Cermet

Abmessungen in mm

Dimensions in mm

Ausführung R, L oder N angeben

State R, L or N version

Bei Nutaußen-Ø < 40 mm bitten wir um Anfrage.

Outer-Ø of groove < 40 mm upon request.

P	•
M	•
K	•
N	•
S	•
H	-

HM-Sorten
Carbide grades

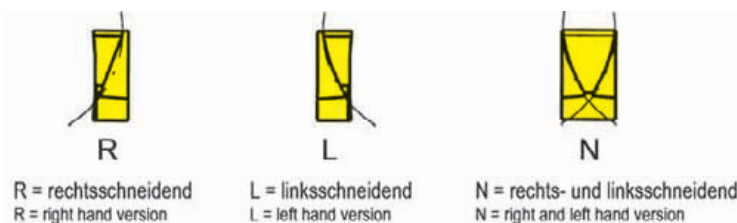

Gewindedrehen (außen) Vollprofil

Threading (external) Full profile



Wendeschneidplatte

Indexable insert

231

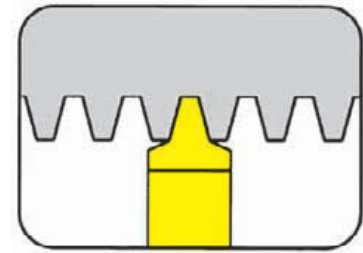

Steigung	Pitch	7-12 mm
----------	-------	---------

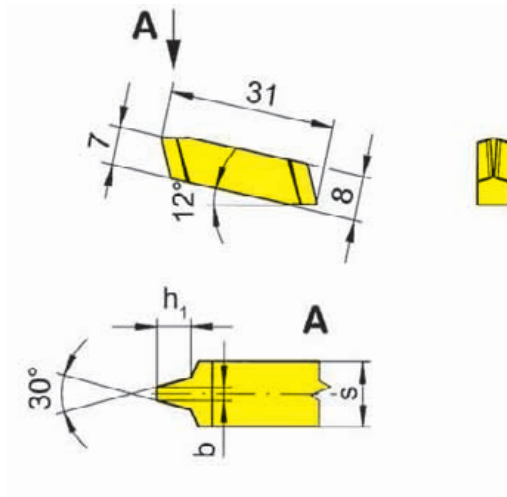

für Klemmhalter
for Toolholder

Typ 221
Type 228

Metrisches ISO
Trapezgewinde DIN 103
Metric ISO trapezoidal
thread DIN 103

Bestellnummer Part number	P	h ₁	b	s	Größe Size	TN35
231.4070.02	7	4,0	2,29	5,8	05	▲
231.4580.02	8	4,5	2,66	5,8	05	▲
231.5090.02	9	5,0	3,02	7,8	07	▲
231.5500.02	10	5,5	3,39	7,8	07	▲
231.6020.02	12	6,5	4,12	9,8	09	▲

▲ ab Lager / on stock Δ 4 Wochen / 4 weeks x auf Anfrage / upon request

● empfohlen / recommended

o bedingt einsetzbar / alternative recommendation

- nicht geeignet / not suitable

■ unbeschichtete HM-Sorten / uncoated grades

■ beschichtete HM-Sorten / coated grades

■ bestückt/Cermet / brazed/Cermet

Abmessungen in mm

Dimensions in mm

Keine Unterlegplatte erforderlich. Sämtliche HORN-Gewindeprofile sind mit einem **KEGELMANTEL-FREISCHLIFF** versehen.

No shims necessary. All HORN thread profiles are manufactured with **full ground radial clearance**.

P	●
M	●
K	●
N	●
S	●
H	-

HM-Sorten
Carbide grades

262



**Klemmhalter mit
Schneidplatten**

Stechbreite 0,025 - 6,0 mm

**Toolholder with
Inserts**

Width of groove 0,025 - 6,0 mm

J

Einstecken (außen)

Grooving (external)



Klemmhalter
Toolholder
262

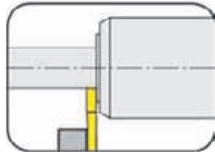

Seite/Page
J3

Wendeschneidplatte
Indexable insert
S262



Seite/Page
J4

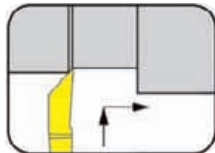

Seite/Page
J5

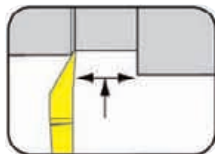

Seite/Page
J6



Seite/Page
J7

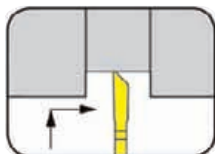

Seite/Page
J8-J9

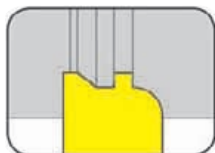

Seite/Page
J10

J

Einstecken und Drehen

Grooving and Turning



Klemmhalter

Toolholder

H262

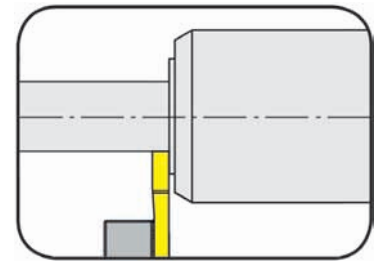

Stechtiefe bis
Stechbreite bis

Depth of groove up to
Width of groove up to

7,5 mm
0,025 - 6,0 mm

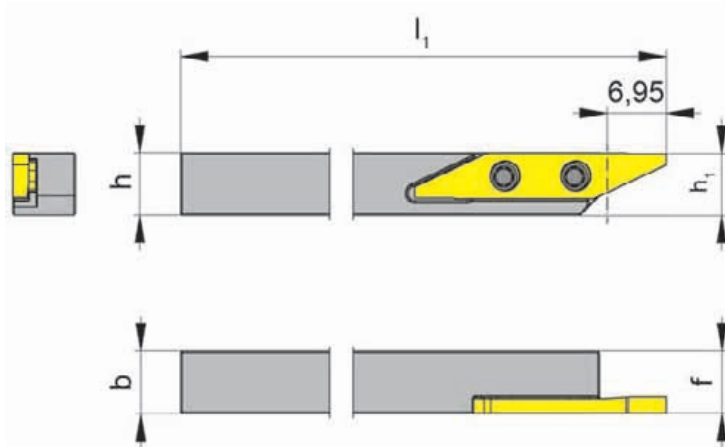

für Wendeschneidplatte
for Indexable insert

Typ LS262
Type

L = links wie gezeichnet
L = left hand version shown

Bestellnummer Part number	h	b	l_1	h_1	f	t_{max}	Größe Size
LH262.0606.04	6	6	100	5,83	5,95	7,5	04
LH262.0707.04	7	7	100	6,83	6,95	7,5	04
LH262.0808.04	8	8	100	7,83	7,95	7,5	04
LH262.0808.2.04	8	8	150	7,83	7,95	7,5	04
LH262.1010.04	10	10	100	9,83	9,95	7,5	04

Weitere Abmessungen auf Anfrage

Further sizes upon request

Das Anzugsdrehmoment der Schrauben finden Sie in den Technischen Hinweisen.
For torque specification of the screw, please see Technical Instructions.

Abmessungen in mm
Dimensions in mm

Ersatzteile

Spare Parts

Klemmhalter Toolholder	Spannschraube Screw	TORX PLUS®-Schlüssel TORX PLUS® Wrench
LH262...	030.2557.T8P	T8PL

J

Einstechen und Längsdrehen

Grooving and Side Turning



Wendeschneidplatte

Indexable insert

S262

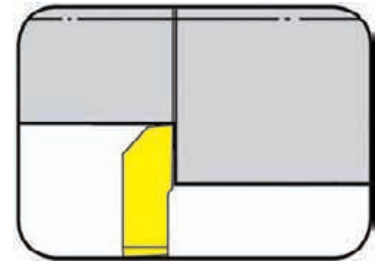

Stechbreite	Width of groove	0,05-2,0 mm
-------------	-----------------	-------------

für Klemhalter
for Toolholder

Typ LH262
Type

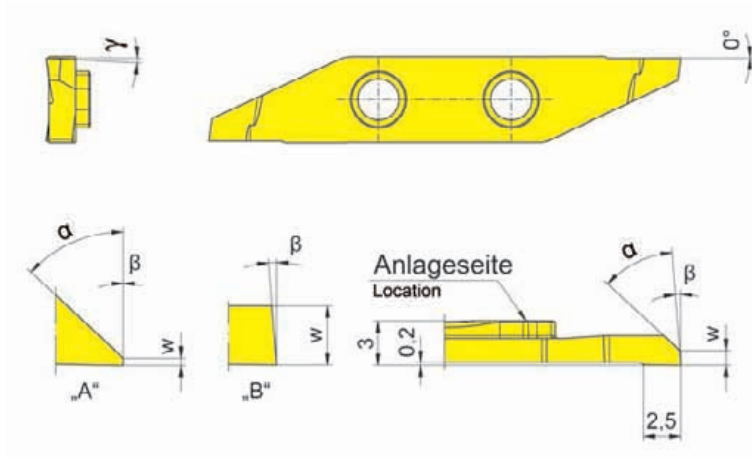

L = links wie gezeichnet
L = left hand version shown

Bestellnummer Part number	w	γ	α	Form Form	β	EG35
LS262.0547.04	0,05	0°	47°	A	0°	▲
LS262.2047.03	2,00	3°	0°	B	4°	Δ

- ▲ ab Lager / on stock Δ 4 Wochen / 4 weeks x auf Anfrage / upon request
- empfohlen / recommended
- o bedingt einsetzbar / alternative recommendation
- nicht geeignet / not suitable
- unbeschichtete HM-Sorten / uncoated grades
- beschichtete HM-Sorten / coated grades
- bestückt/Cermet / brazed/Cermet

Abmessungen in mm
Dimensions in mm

HM-Sorten
Carbide grades

P	●
M	●
K	○
N	-
S	-
H	-

Kopierdrehen (Schlichten)

Copy Turning (Finishing)



Wendeschneidplatte

S262

Indexable insert

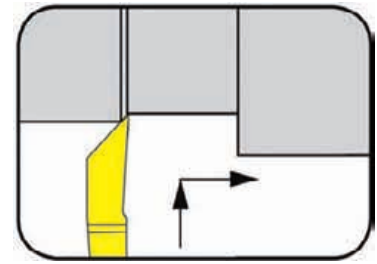

Schneidbreite Schnitttiefe bis	Width of groove Depth of cut up to	0,025 mm 1,8 mm
-----------------------------------	---------------------------------------	--------------------

für Klemmhalter
for Toolholder

Typ LH262
Type

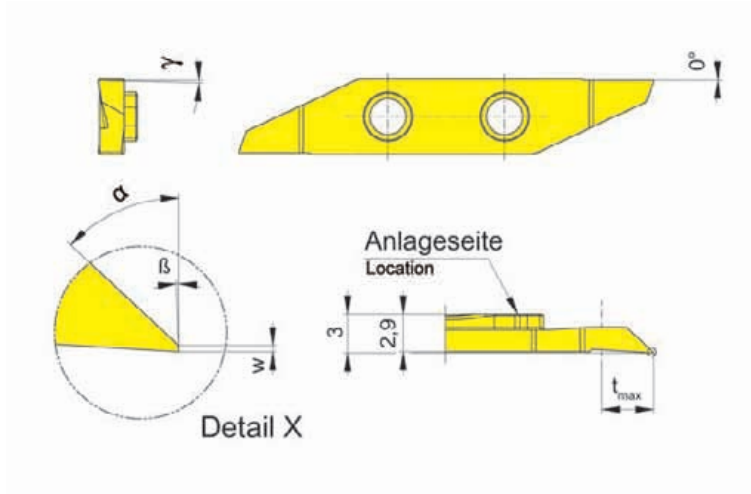

L = links wie gezeichnet
L = left hand version shown

Bestellnummer Part number	w	t _{max}	γ	α	β	EG35
LS262.0247.04	0,025	1,8	1,5°	47°	2°	▲

▲ ab Lager / on stock Δ 4 Wochen / 4 weeks x auf Anfrage / upon request

● empfohlen / recommended

o bedingt einsetzbar / alternative recommendation

- nicht geeignet / not suitable

□ unbeschichtete HM-Sorten / uncoated grades

■ beschichtete HM-Sorten / coated grades

■ bestückt/Cermet / brazed/Cermet

Abmessungen in mm

Dimensions in mm

HM-Sorten
Carbide grades

P	●
M	●
K	○
N	-
S	-
H	-

J

Wendeschneidplatte

Indexable insert

S262

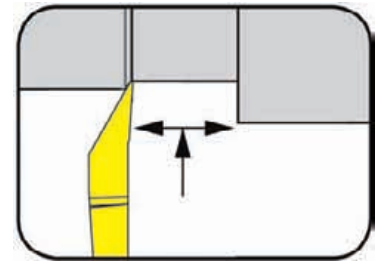

Schneidbreite Schnitttiefe bis	Width of groove Depth of cut up to	0,03-0,105 mm 3 mm
-----------------------------------	---------------------------------------	-----------------------

für Klemhalter
for Toolholder

Typ LH262
Type

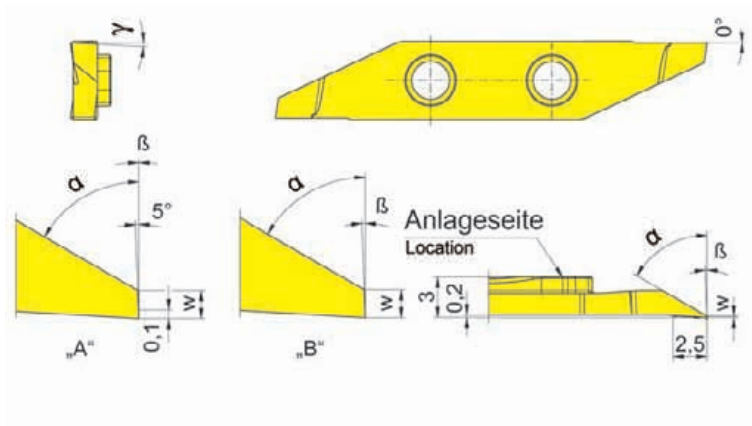

L = links wie gezeichnet
L = left hand version shown

Bestellnummer Part number	w	t _{max}	γ	α	Form Form	β	EG35
LS262.0147.04	0,030	1,8	0°	47°	A	0°	▲
LS262.0160.03	0,105	3,0	3°	60°	B	2°	▲

- ▲ ab Lager / on stock Δ 4 Wochen / 4 weeks x auf Anfrage / upon request
- empfohlen / recommended
- o bedingt einsetzbar / alternative recommendation
- nicht geeignet / not suitable
- unbeschichtete HM-Sorten / uncoated grades
- beschichtete HM-Sorten / coated grades
- bestückt/Cermet / brazed/Cermet

Abmessungen in mm
Dimensions in mm

HM-Sorten
Carbide grades

P	●
M	●
K	○
N	-
S	-
H	-

Abstechen

Parting Off



Wendeschneidplatte

Indexable insert

S262

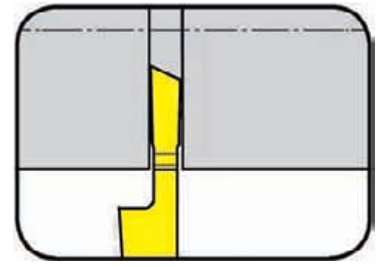

Schneidbreite Schnitttiefe bis	Width of groove Depth of cut up to	0,7-1 mm 5 mm
-----------------------------------	---------------------------------------	------------------

für Klemhalter
for Toolholder

Typ LH262
Type

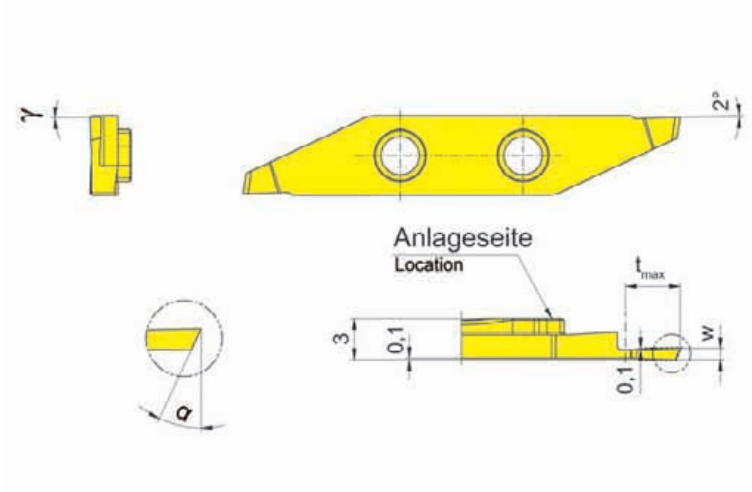

L = links wie gezeichnet
L = left hand version shown

Bestellnummer Part number	w	t _{max}	γ	α	EG35
LS262.2007.02	0,7	2	0°	20°	▲
LS262.2508.03	0,8	3	0°	25°	▲
LS262.2509.04	0,9	4	0°	25°	▲
LS262.2510.05	1,0	5	0°	25°	▲

▲ ab Lager / on stock Δ 4 Wochen / 4 weeks x auf Anfrage / upon request

● empfohlen / recommended

o bedingt einsetzbar / alternative recommendation

- nicht geeignet / not suitable

■ unbeschichtete HM-Sorten / uncoated grades

■ beschichtete HM-Sorten / coated grades

■ bestückt/Cermet / brazed/Cermet

Abmessungen in mm

Dimensions in mm

P	●
M	●
K	○
N	-
S	-
H	-

HM-Sorten
Carbide grades

J

Einstechen/Rückwärtsdrehen

Grooving/Backturning



Wendeschneidplatte

Indexable insert

S262

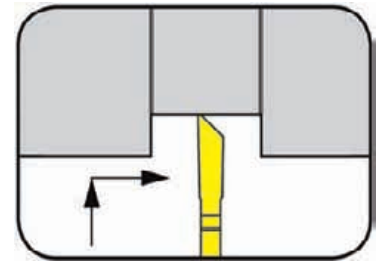

Schneidbreite Schnitttiefe bis	Width of groove Depth of cut up to	0,8-1,8 mm 6 mm
-----------------------------------	---------------------------------------	--------------------

für Klemhalter
for Toolholder

Typ LH262
Type

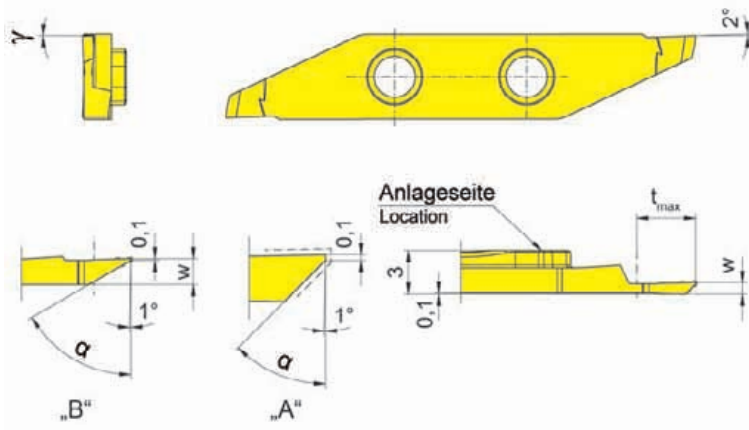

L = links wie gezeichnet
L = left hand version shown

Bestellnummer Part number	w	t _{max}	γ	α	Form Form	EG35
LS262.4508.04	0,8	2,0	0°	45°	A	▲
LS262.4509.04	0,9	4,0	0°	45°	A	▲
LS262.4510.06	1,0	6,0	0°	45°	A	▲
LS262.4512.06	1,2	6,0	0°	45°	A	▲
LS262.6015.02	1,8	2,5	0°	60°	B	▲
LS262.7010.02	1,2	2,5	0°	70°	B	▲

▲ ab Lager / on stock Δ 4 Wochen / 4 weeks x auf Anfrage / upon request

● empfohlen / recommended

o bedingt einsetzbar / alternative recommendation

- nicht geeignet / not suitable

■ unbeschichtete HM-Sorten / uncoated grades

■ beschichtete HM-Sorten / coated grades

■ bestückt/Cermet / brazed/Cermet

Abmessungen in mm

Dimensions in mm

P	●
M	●
K	○
N	-
S	-
H	-

HM-Sorten
Carbide grades

Einstecken/Rückwärtsdrehen

Grooving/Backturning



Wendeschneidplatte

Indexable insert

S262

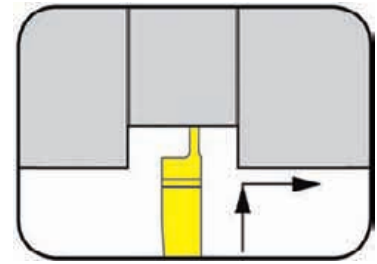

Schneidbreite Schnitttiefe bis	Width of groove Depth of cut up to	0,5-2 mm 3 mm
-----------------------------------	---------------------------------------	------------------

für Klemmhalter
for Toolholder

Typ LH262
Type

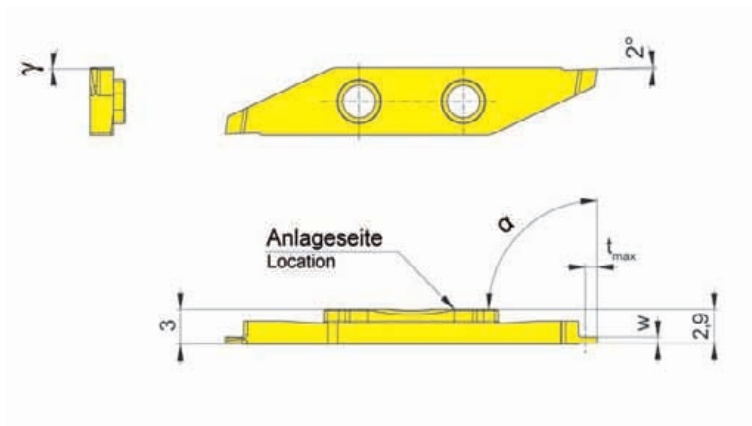

L = links wie gezeichnet
L = left hand version shown

Bestellnummer Part number	w	t _{max}	γ	α	EG35
LS262.0005.01	0,5	1	0°	90°	▲
LS262.0010.02	1,0	2	0°	90°	▲
LS262.0012.02	1,2	2	0°	90°	▲
LS262.0015.03	1,5	3	0°	90°	▲
LS262.0020.03	2,0	3	0°	90°	▲

▲ ab Lager / on stock Δ 4 Wochen / 4 weeks x auf Anfrage / upon request

● empfohlen / recommended

o bedingt einsetzbar / alternative recommendation

- nicht geeignet / not suitable

□ unbeschichtete HM-Sorten / uncoated grades

■ beschichtete HM-Sorten / coated grades

■ bestückt/Cermet / brazed/Cermet

Abmessungen in mm

Dimensions in mm

P	●
M	●
K	○
N	-
S	-
H	-

HM-Sorten
Carbide grades



Halbzeug

Semi-finished Insert



Wendeschneidplatte

Indexable insert

S262

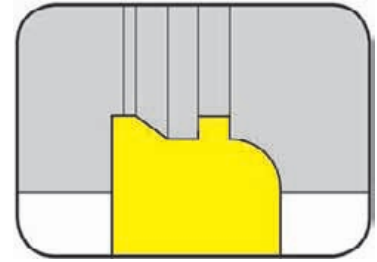

Schneidbreite Schnitttiefe bis	Width of groove Depth of cut up to	2 mm 7,5 mm
-----------------------------------	---------------------------------------	----------------

für Klemhalter
for Toolholder

Typ LH262
Type

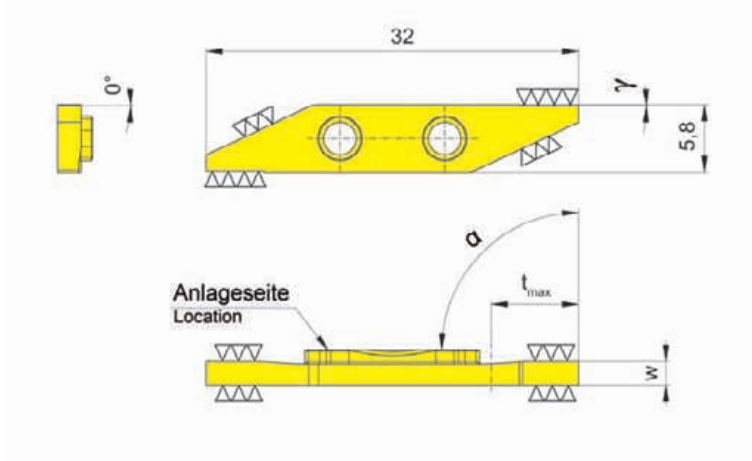

L = links wie gezeichnet
L = left hand version shown

Bestellnummer Part number	w	t _{max}	γ	α	MG12
LS262.8520.06	2	7,5	0°	90°	▲

▲ ab Lager / on stock Δ 4 Wochen / 4 weeks x auf Anfrage / upon request

● empfohlen / recommended

○ bedingt einsetzbar / alternative recommendation

- nicht geeignet / not suitable

□ unbeschichtete HM-Sorten / uncoated grades

■ beschichtete HM-Sorten / coated grades

■ bestückt/Cermet / brazed/Cermet

Abmessungen in mm

Dimensions in mm

P	○
M	●
K	●
N	●
S	●
H	-

HM-Sorten
Carbide grades

J

264



**Klemmhalter mit
Schneidplatten**

Stechbreite 1,5 - 3 mm

**Toolholder with
Inserts**

Width of groove 1,5 - 3 mm

K

Einstecken und Längsdrehen (außen)

Grooving and Side Turning (external)



Klemmhalter
Toolholder
H264

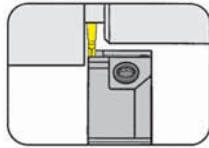

Seite/Page
K3-K6

Wendeschneidplatte
Indexable insert
264

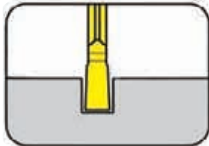

Seite/Page
K7, K9, K11



Seite/Page
K8, K10

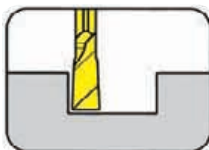

Seite/Page
K12-K13

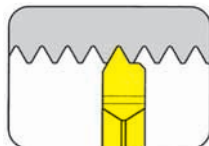

Seite/Page
K14

Einstechen und Abstechen

Grooving and Parting Off



Klemmhalter

Toolholder

H264

mit Schraubklemmung
with screwed clamping

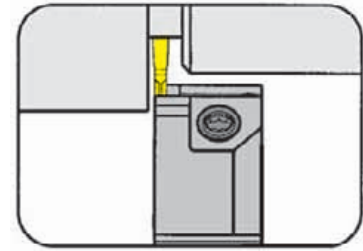

Stechtiefe bis
Stechbreite

Depth of groove up to
Width of groove

16 mm
1,5-2,0 mm

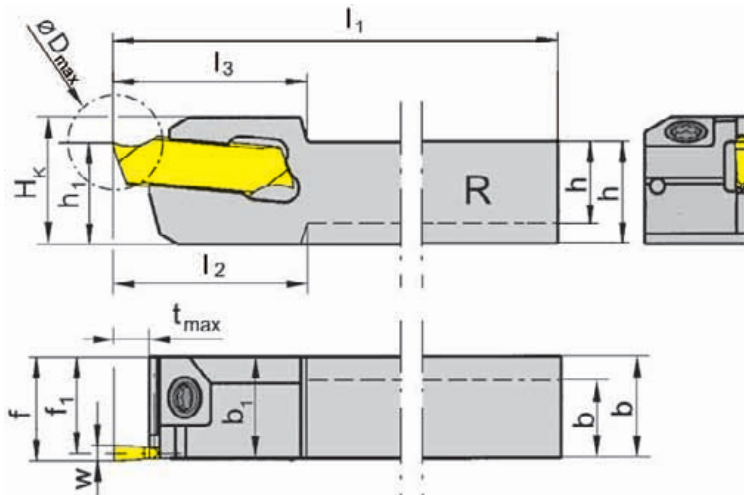

R = rechts wie gezeichnet
R = right hand version shown

L = links spiegelbildlich
L = left hand version

für Wendeschneidplatte
for Indexable insert

Typ 264
Type S264

Bestellnummer Part number	h	b	l ₁	l ₂	l ₃	h ₁	f ₁	t _{max}	D _{max}	H _K	f	b ₁	Größe Size
R/LH264.0808.01	8	8	120	17,5	17,5	8	9,25	4	22	12,5	10	10	01
R/LH264.1010.01	10	10	120	-	17,5	10	9,25	4	22	12,5	10	-	01
R/LH264.1212.01	12	12	120	-	17,5	12	11,25	4	22	14,5	12	-	01
R/LH264.1616.01	16	16	120	-	17,5	16	15,25	4	32	18,5	16	-	01
R/LH264.1010.11	10	10	120	-	19,0	10	9,25	10	20	12,5	10	-	01
R/LH264.1212.11	12	12	120	-	19,0	12	11,25	10	20	14,5	12	-	01
R/LH264.1616.11	16	16	120	-	19,0	16	15,25	10	32	18,5	16	-	01
R/LH264.1212.21	12	12	120	-	22,0	12	11,25	13	26	15,5	12	-	01
R/LH264.1616.21	16	16	120	-	22,0	16	15,25	13	32	19,5	16	-	01
R/LH264.1010.02	10	10	120	-	17,5	10	9,00	4	32	12,5	10	-	02
R/LH264.1212.02	12	12	120	-	17,5	12	11,00	4	32	14,5	12	-	02
R/LH264.1616.02	16	16	120	-	17,5	16	15,00	4	32	18,5	16	-	02
R/LH264.1010.12	10	10	120	-	19,0	10	9,00	10	32	12,5	10	-	02
R/LH264.1212.12	12	12	120	-	19,0	12	11,00	10	32	14,5	12	-	02
R/LH264.1616.12	16	16	120	-	19,0	16	15,00	10	32	18,5	16	-	02
R/LH264.1212.22	12	12	120	-	25,0	12	11,00	16	32	14,5	12	-	02
R/LH264.1616.22	16	16	120	-	25,0	16	15,00	16	32	19,5	16	-	02

Ausführung R oder L angeben
State R or L version

w siehe Schneidplatten
w see Inserts

Abmessungen in mm
Dimensions in mm

Das Anzugsdrehmoment der Schrauben finden Sie in den Technischen Hinweisen.
For torque specification of the screw, please see Technical Instructions.

Weitere Abmessungen auf Anfrage
Further sizes upon request

Ersatzteile

Spare Parts

Klemmhalter Toolholder	Spannschraube Screw	TORX PLUS®-Schlüssel TORX PLUS® Wrench
R/LH264...	3.5.12T10EP	T10PL

Einstechen und Abstechen

Grooving and Parting Off



Klemmhalter

Toolholder

H264

mit Schraubklemmung
with screwed clamping

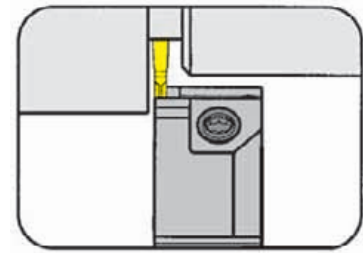

Stechtiefe bis Stechbreite	Depth of groove up to Width of groove	16 mm 2,5mm
-------------------------------	--	----------------

für Wendeschneidplatte
for Indexable insert

Typ 264
Type S264

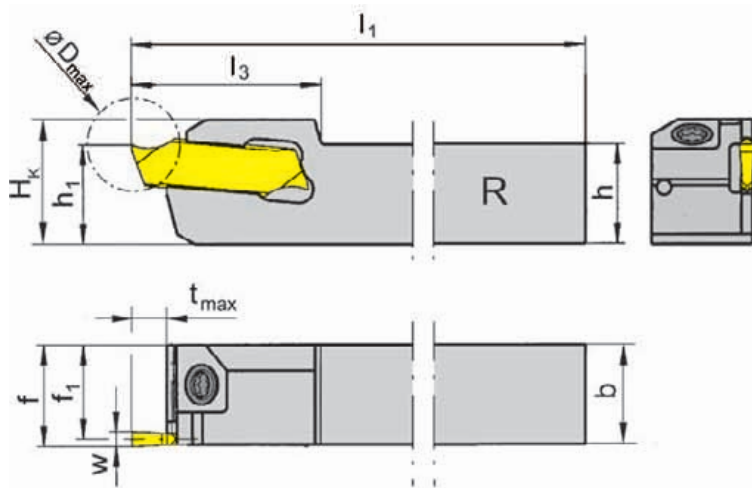

R = rechts wie gezeichnet
R = right hand version shown

L = links spiegelbildlich
L = left hand version

Bestellnummer Part number	h	b	l ₁	l ₃	h ₁	f ₁	t _{max}	D _{max}	H _k	f	Größe Size
R/LH264.1212.03	12	12	120	17,5	12	10,75	4	32	14,5	12	03
R/LH264.1616.03	16	16	120	17,5	16	14,75	4	32	18,5	16	03
R/LH264.1212.13	12	12	120	19,0	12	10,75	10	32	14,5	12	03
R/LH264.1616.13	16	16	120	19,0	16	14,75	10	32	18,5	16	03
R/LH264.1212.23	12	12	120	25,0	12	10,75	16	32	14,5	12	03
R/LH264.1616.23	16	16	120	25,0	16	14,75	16	32	18,5	16	03

Ausführung R oder L angeben
State R or L version

w siehe Schneidplatten
w see Inserts

Abmessungen in mm
Dimensions in mm

Weitere Abmessungen auf Anfrage
Further sizes upon request

Das Anzugsdrehmoment der Schrauben finden Sie in den Technischen Hinweisen.
For torque specification of the screw, please see Technical Instructions.

K

Ersatzteile

Spare Parts

Klemmhalter Toolholder	Spannschraube Screw	TORX PLUS®-Schlüssel TORX PLUS® Wrench
R/LH264...	3.5.12T10EP	T10PL

Einstechen und Abstechen

Grooving and Parting Off



Klemmhalter

Toolholder

H264

mit Schraubklemmung
with screwed clamping

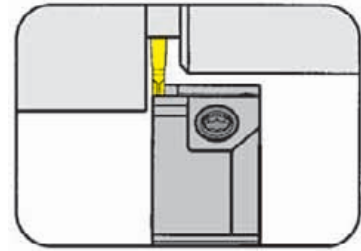

Stechtiefe bis Stechbreite	Depth of groove up to Width of groove	16 mm 3,0 mm
-------------------------------	--	-----------------

für Wendeschneidplatte
for Indexable insert

Typ 264
Type S264

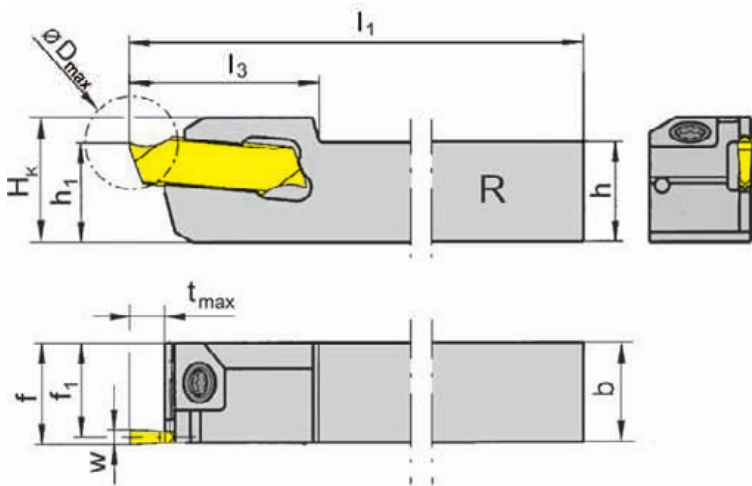

R = rechts wie gezeichnet
R = right hand version shown

L = links spiegelbildlich
L = left hand version

Bestellnummer Part number	h	b	l ₁	l ₃	h ₁	f ₁	t _{max}	D _{max}	H _K	f	Größe Size
R/LH264.1212.04	12	12	120	17,5	12	10,5	5	32	15	12	04
R/LH264.1616.04	16	16	120	17,5	16	14,5	5	32	19	16	04
R/LH264.1212.14	12	12	120	19,0	12	10,5	10	32	15	12	04
R/LH264.1616.14	16	16	120	19,0	16	14,5	10	32	19	16	04
R/LH264.1212.24	12	12	120	25,0	12	10,5	16	32	15	12	04
R/LH264.1616.24	16	16	120	25,0	16	14,5	16	32	19	16	04

Ausführung R oder L angeben
State R or L version

w siehe Schneidplatten
w see Inserts

Abmessungen in mm
Dimensions in mm

Weitere Abmessungen auf Anfrage
Further sizes upon request

Das Anzugsdrehmoment der Schrauben finden Sie in den Technischen Hinweisen.
For torque specification of the screw, please see Technical Instructions.

Ersatzteile

Spare Parts

Klemmhalter Toolholder	Spannschraube Screw	TORX PLUS®-Schlüssel TORX PLUS® Wrench
R/LH264...	3.5.12T10EP	T10PL

Einstechen und Abstechen

Grooving and Parting Off



Klemmhalter

Toolholder

H264

mit Selbstklemmung
with self clamping

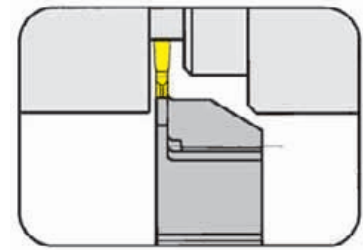

Stechtiefe bis Stechbreite	Depth of groove up to Width of groove	10 mm 1,5-3,0mm
-------------------------------	--	--------------------

für Wendeschneidplatte
for Indexable insert

Typ 264
Type S264

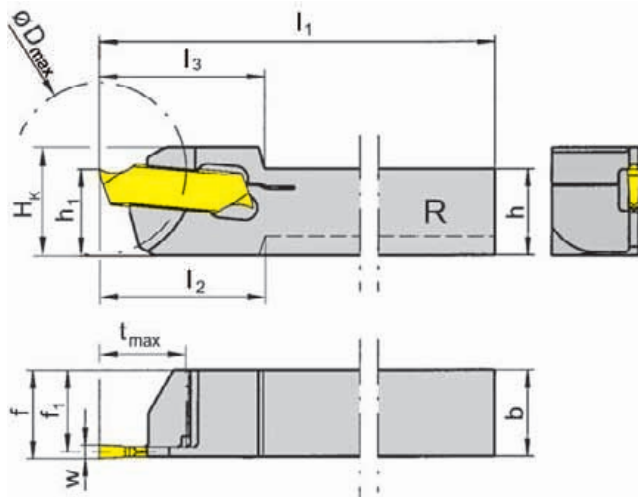

R = rechts wie gezeichnet
R = right hand version shown

L = links spiegelbildlich
L = left hand version

Bestellnummer Part number	h	b	l ₁	l ₂	l ₃	h ₁	f ₁	t _{max}	D _{max}	H _k	f	Größe Size
R/LH264.0808.51	8	8	120	18	18	10	7,25	7	20	12,5	8	01
R/LH264.1010.61	10	10	120	-	19	10	9,25	10	20	12,5	10	01
R/LH264.1010.62	10	10	120	-	19	10	9,00	10	20	12,5	10	02
R/LH264.1212.62	12	12	120	-	19	12	11,00	10	20	14,5	12	02
R/LH264.1212.63	12	12	120	-	19	12	10,75	10	32	14,5	12	03
R/LH264.1212.64	12	12	120	-	19	12	10,50	10	32	14,5	12	04

Ausführung R oder L angeben
State R or L version

w siehe Schneidplatten
w see Inserts

Abmessungen in mm
Dimensions in mm

Weitere Abmessungen auf Anfrage
Further sizes upon request

Hinweis:

Der Schlüssel **P39L** gehört nicht zum Lieferumfang des Schneidträgers R/LH100...33. Bitte separat bestellen!

Note:

Wrench **P39L** is not combined with blade R/LH100...33 - separate order required!

Einstechen und Abstechen

Grooving and Parting Off



Wendeschneidplatte

Indexable insert

264

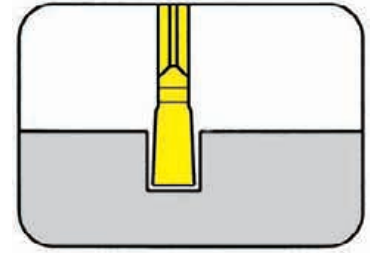

Stechtiefe bis Stechbreite	Depth of groove up to Width of groove	16 mm 1,5-3 mm
-------------------------------	--	-------------------

präzisionsgeschliffen
precision ground

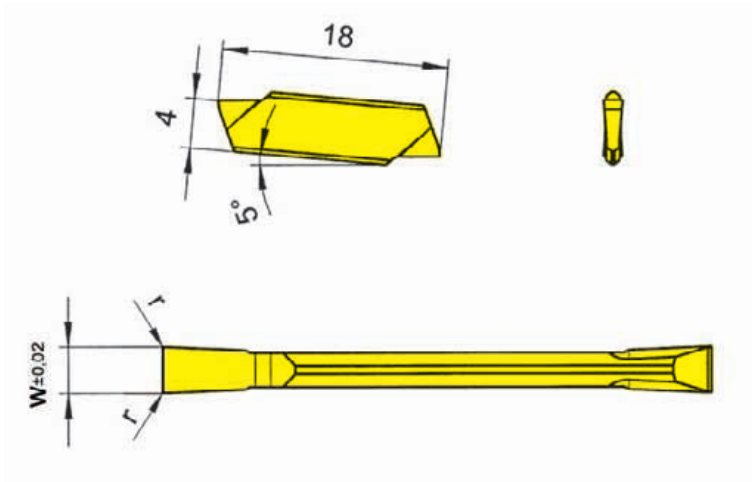

für Klemhalter
for Toolholder

Typ H264
Type

Wechselgenauigkeit
Länge ± 0,015 mm
Indexability length
± 0,015 mm

Bestellnummer Part number	w	r	Größe Size	MG12	TH35	TN35
264.0150.M0	1,5	0,05	01	▲	▲	▲
264.0200.M0	2,0	0,05	02	▲	▲	▲
264.0250.M0	2,5	0,10	03	▲	▲	▲
264.0300.M0	3,0	0,10	04	▲	▲	▲
				P	o	•
				M	•	•
				K	•	•
				N	•	•
				S	•	•
				H	-	-

- ▲ ab Lager / on stock Δ 4 Wochen / 4 weeks x auf Anfrage / upon request
- empfohlen / recommended
- o bedingt einsetzbar / alternative recommendation
- nicht geeignet / not suitable
- unbeschichtete HM-Sorten / uncoated grades
- beschichtete HM-Sorten / coated grades
- bestückt/Cermet / brazed/Cermet

Abmessungen in mm
Dimensions in mm

Wendeschneidplatten sind in rechten und linken Klemmhaltern verwendbar.
Indexable inserts can be used in right and left hand toolholders.

HM-Sorten
Carbide grades



Abstechen

Parting Off



Wendeschneidplatte

Indexable insert

264

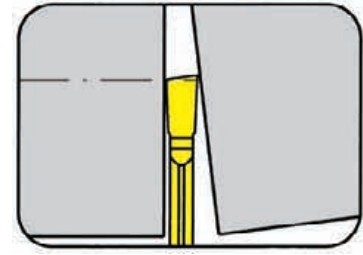

Stechtiefe bis Stechbreite	Depth of groove up to Width of groove	16 mm 1,5-3 mm
-------------------------------	--	-------------------

präzisionsgeschliffen
precision ground

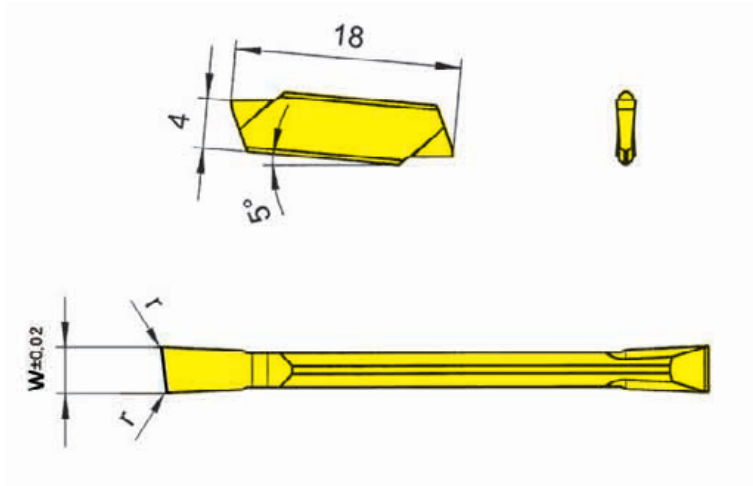

für Klemmhalter
for Toolholder

Typ H264
Type

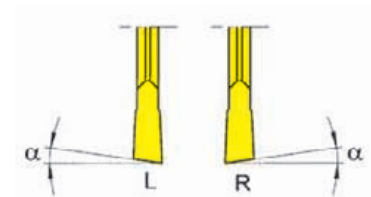

Wechselgenauigkeit
Länge ± 0,015 mm
Indexability length
± 0,015 mm

R = rechts wie gezeichnet
R = right hand version shown

L = links spiegelbildlich
L = left hand version

Bestellnummer Part number	w	r	α	Größe Size	MG12	TH35	TN35
R/L264.0815.M0	1,5	0,05	8°	01	Δ/▲	Δ/Δ	▲/Δ
R/L264.1515.M0	1,5	0,05	15°	01	▲/Δ	Δ/Δ	▲/Δ
R/L264.0820.M0	2,0	0,05	8°	02	Δ/Δ	Δ/Δ	Δ/Δ
R/L264.1520.M0	2,0	0,05	15°	02	Δ/Δ	Δ/Δ	▲/Δ
R/L264.0825.M0	2,5	0,10	8°	03	Δ/Δ	Δ/Δ	Δ/Δ
R/L264.1525.M0	2,5	0,10	15°	03	Δ/Δ	Δ/x	▲/Δ
R/L264.0830.M0	3,0	0,10	8°	04	Δ/Δ	Δ/Δ	Δ/Δ
R/L264.1530.M0	3,0	0,10	15°	04	Δ/Δ	Δ/Δ	Δ/Δ

- ▲ ab Lager / on stock Δ 4 Wochen / 4 weeks x auf Anfrage / upon request
- empfohlen / recommended
- o bedingt einsetzbar / alternative recommendation
- nicht geeignet / not suitable
- unbeschichtete HM-Sorten / uncoated grades
- beschichtete HM-Sorten / coated grades
- bestückt/Cermet / brazed/Cermet

P	○	●	●
M	●	●	●
K	●	●	●
N	●	●	●
S	●	●	●
H	-	-	-

HM-Sorten
Carbide grades

Abmessungen in mm
Dimensions in mm

Ausführung R oder L angeben
State R or L version

Wendeschneidplatten sind in rechten und linken Klemmhaltern verwendbar.
Indexable inserts can be used in right and left hand toolholders.

K

Einstechen und Abstechen

Grooving and Parting Off



Wendeschneidplatte

Indexable insert

264

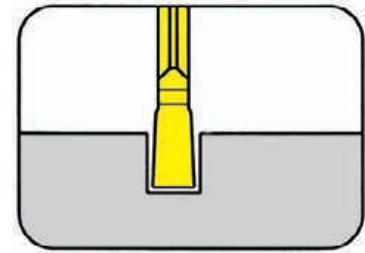

Stechtiefe bis Stechbreite	Depth of groove up to Width of groove	16 mm 1,5-3 mm
-------------------------------	--	-------------------

präzisionsgeschliffen
precision ground

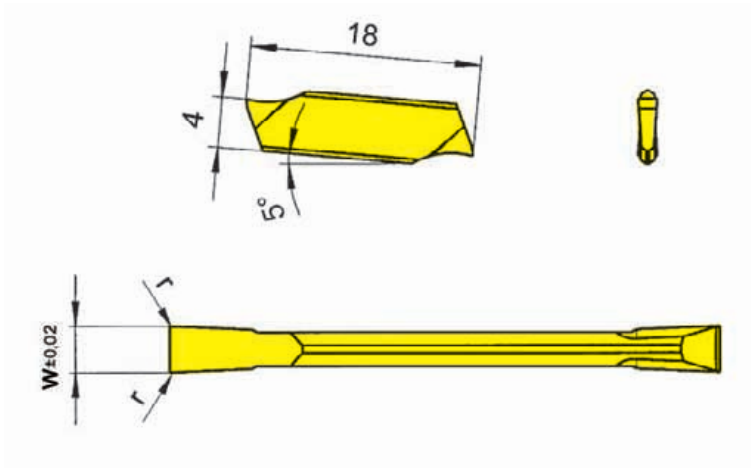

für Klemmhalter
for Toolholder

Typ H264
Type

Wechselgenauigkeit
Länge ± 0,015 mm
Indexability length
± 0,015 mm

Bestellnummer Part number	w	r	Größe Size	MG12	TH35	TI25	TN35
264.0150.10	1,5	0,05	01	▲	△	△	▲
264.0200.10	2,0	0,05	02	▲	△	△	▲
264.0250.10	2,5	0,10	03	△	△	△	▲
264.0300.10	3,0	0,10	04	△	△	△	▲
				P	o	•	•
				M	•	•	•
				K	•	•	•
				N	•	•	•
				S	•	•	•
				H	-	-	-

- ▲ ab Lager / on stock △ 4 Wochen / 4 weeks x auf Anfrage / upon request
- empfohlen / recommended
- o bedingt einsetzbar / alternative recommendation
- nicht geeignet / not suitable
- unbeschichtete HM-Sorten / uncoated grades
- beschichtete HM-Sorten / coated grades
- bestückt/Cermet / brazed/Cermet

Abmessungen in mm
Dimensions in mm

Wendeschneidplatten sind in rechten und linken Klemmhaltern verwendbar.
Indexable inserts can be used in right and left hand toolholders.

HM-Sorten
Carbide grades



Abstechen

Parting Off



Wendeschneidplatte

Indexable insert

264

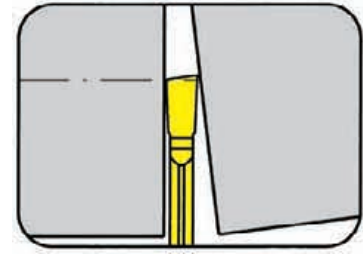

Stechtiefe bis Stechbreite	Depth of groove up to Width of groove	16 mm 1,5-3 mm
-------------------------------	--	-------------------

präzisionsgeschliffen
precision ground

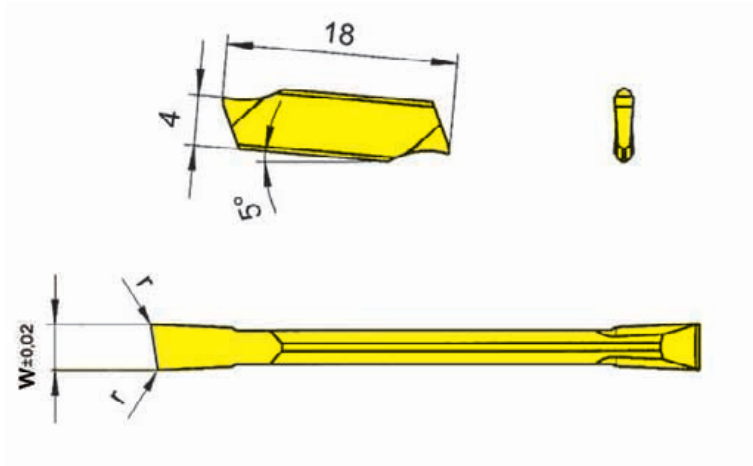

für Klemmhalter
for Toolholder

Typ H264
Type

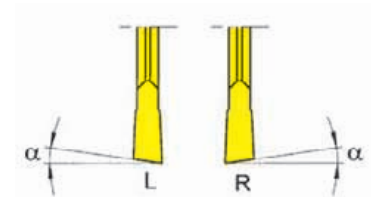

Wechselgenauigkeit
Länge ± 0,015 mm
Indexability length
± 0,015 mm

R = rechts wie gezeichnet
R = right hand version shown

L = links spiegelbildlich
L = left hand version

Bestellnummer Part number	w	r	α	Größe Size	HM-Sorten Carbide grades			
					MG12	TH35	TI25	TN35
R/L264.0815.10	1,5	0,05	8°	01	▲/Δ	Δ/Δ	Δ/Δ	▲/▲
R/L264.1515.10	1,5	0,05	15°	01	▲/▲	Δ/Δ		▲/▲
R/L264.0820.10	2,0	0,05	8°	02	▲/▲	Δ/Δ		▲/▲
R/L264.1520.10	2,0	0,05	15°	02	▲/▲	Δ/Δ		▲/▲
R/L264.0825.10	2,5	0,10	8°	03	Δ/Δ	Δ/Δ		▲/Δ
R/L264.1525.10	2,5	0,10	15°	03	Δ/Δ	Δ/Δ		▲/Δ
R/L264.0830.10	3,0	0,10	8°	04	Δ/Δ	Δ/Δ		Δ/Δ
R/L264.1530.10	3,0	0,10	15°	04	Δ/Δ	Δ/Δ		▲/▲

- ▲ ab Lager / on stock Δ 4 Wochen / 4 weeks x auf Anfrage / upon request
- empfohlen / recommended
- o bedingt einsetzbar / alternative recommendation
- nicht geeignet / not suitable
- unbeschichtete HM-Sorten / uncoated grades
- beschichtete HM-Sorten / coated grades
- bestückt/Cermet / brazed/Cermet

P	○	●	●	●
M	●	●	●	●
K	●	●	●	●
N	●	●	●	●
S	●	●	●	●
H	-	-	-	-

HM-Sorten
Carbide grades

Abmessungen in mm
Dimensions in mm

Ausführung R oder L angeben
State R or L version

Wendeschneidplatten sind in rechten und linken Klemmhaltern verwendbar.
Indexable inserts can be used in right and left hand toolholders.

K

Einstechen und Abstechen

Grooving and Parting Off



Wendeschneidplatte

Indexable insert

264

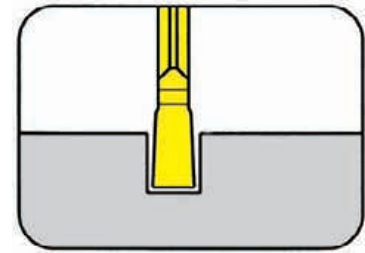

Stechtiefe bis Stechbreite	Depth of groove up to Width of groove	16 mm 1,5-3 mm
-------------------------------	--	-------------------

präzisionsgeschliffen
precision ground

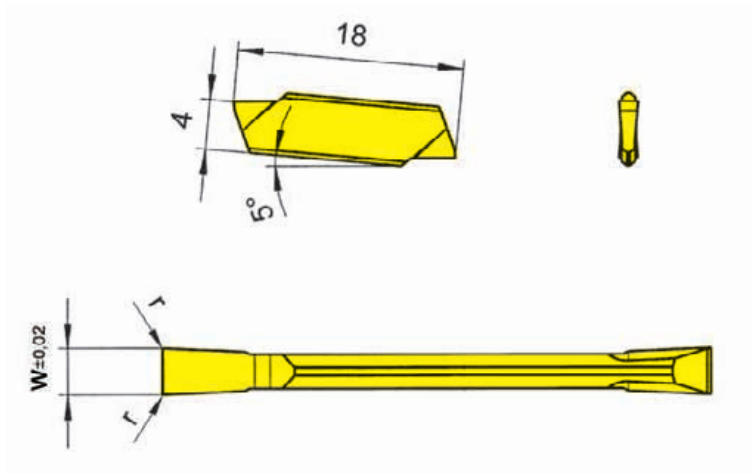

für Klemmhalter
for Toolholder

Typ H264
Type

Wechselgenauigkeit
Länge ± 0,015 mm
Indexability length
± 0,015 mm

Bestellnummer Part number	w	r	Größe Size	MG12	TH35	TI25	TN35
264.0150.20	1,5	0,05	01	Δ	Δ	Δ	▲
264.0200.20	2,0	0,05	02	Δ	Δ		▲
264.0250.20	2,5	0,10	03	Δ	Δ		▲
264.0300.20	3,0	0,10	04	Δ	Δ		▲
				P	o	•	•
				M	•	•	•
				K	•	•	•
				N	•	•	•
				S	•	•	•
				H	-	-	-

- ▲ ab Lager / on stock Δ 4 Wochen / 4 weeks x auf Anfrage / upon request
- empfohlen / recommended
- o bedingt einsetzbar / alternative recommendation
- nicht geeignet / not suitable
- unbeschichtete HM-Sorten / uncoated grades
- beschichtete HM-Sorten / coated grades
- bestückt/Cermet / brazed/Cermet

Abmessungen in mm
Dimensions in mm

Wendeschneidplatten sind in rechten und linken Klemmhaltern verwendbar.
Indexable inserts can be used in right and left hand toolholders.

HM-Sorten
Carbide grades



Einstechen und Längsdrehen

Grooving and Side Turning



Wendeschneidplatte

Indexable insert

264

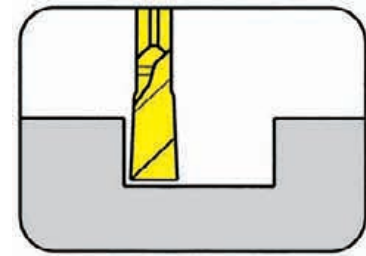

Stechtiefe bis Stechbreite	Depth of groove up to Width of groove	16 mm 1,5-3 mm
-------------------------------	--	-------------------

präzisionsgeschliffen
precision ground

für Klemhalter
for Toolholder

Typ H264
Type

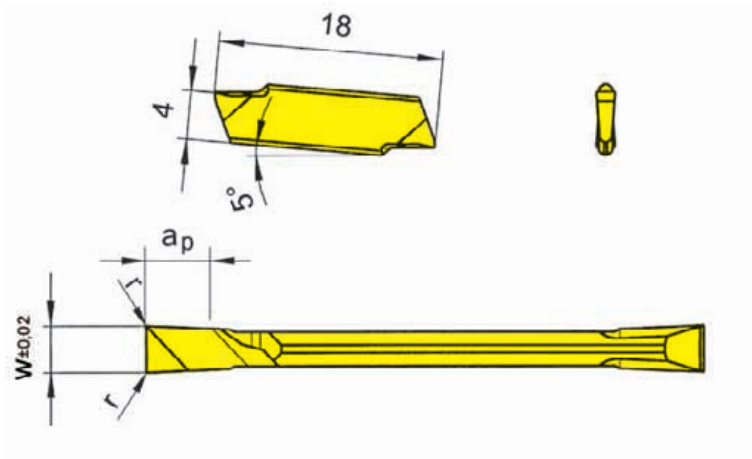

Wechselgenauigkeit
Länge ± 0,015 mm
Indexability length
± 0,015 mm

L = links wie gezeichnet
L = left hand version shown

R = rechts spiegelbildlich
R = right hand version

Bestellnummer Part number	w	r	Größe Size	MG12	TH35	TI25	TN35
R/L264.0150.P0	1,5	0,05	01	△△	△△	▲/△	▲/▲
R/L264.0200.P0	2,0	0,05	02	▲/△	△△	▲/▲	▲/△
R/L264.0200.P2	2,0	0,20	02				△△
R/L264.0250.P0	2,5	0,10	03	△△	△△	△△	▲/△
R/L264.0250.P2	2,5	0,20	03				△△
R/L264.0300.P0	3,0	0,10	04	△△	△△	▲/▲	▲/▲
R/L264.0300.P2	3,0	0,20	04				△△

- ▲ ab Lager / on stock △ 4 Wochen / 4 weeks x auf Anfrage / upon request
- empfohlen / recommended
- o bedingt einsetzbar / alternative recommendation
- nicht geeignet / not suitable
- unbeschichtete HM-Sorten / uncoated grades
- beschichtete HM-Sorten / coated grades
- bestückt/Cermet / brazed/Cermet

P	○	●	●	●
M	●	●	●	●
K	●	●	●	●
N	●	●	●	●
S	●	●	●	●
H	-	-	-	-

Abmessungen in mm
Dimensions in mm

$$a_p = 1,5 \times w$$

$$ap = 1,5 \times w$$

HM-Sorten
Carbide grades

Ausführung R oder L angeben
State R or L version

Wendeschneidplatten sind in rechten und linken Klemmaltern verwendbar.
Indexable inserts can be used in right and left hand toolholders.

K

Einstechen und Längsdrehen

Grooving and Side Turning



Wendeschneidplatte

Indexable insert

S264

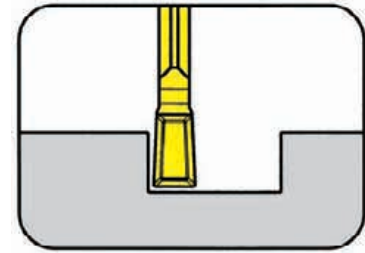

Stechtiefe bis Stechbreite	Depth of groove up to Width of groove	16 mm 1,5-3 mm
-------------------------------	--	-------------------

präzisionsgesintert
precision sintered

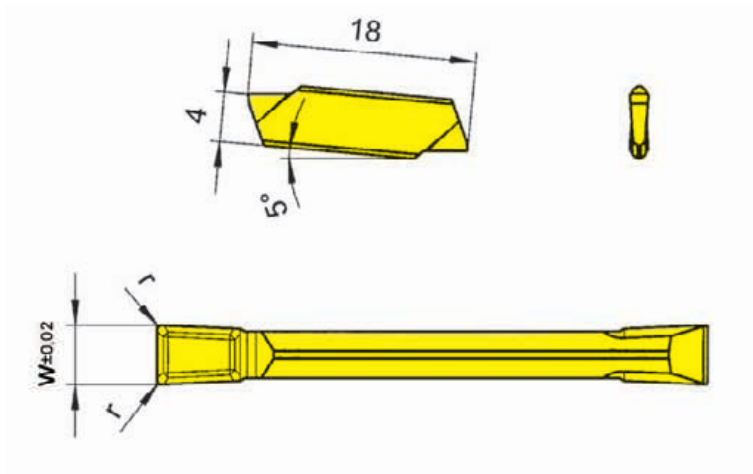

für Klemmhalter
for Toolholder

Typ H264
Type

Wechselgenauigkeit
Länge ± 0,015 mm
Indexability length
± 0,015 mm

Bestellnummer Part number	w	r	Größe Size	MG12	TN35
S264.0150.D1	1,5	0,05	01	Δ	▲
S264.0200.D1	2,0	0,05	02	Δ	▲
S264.0250.D1	2,5	0,10	03	Δ	▲
S264.0300.D1	3,0	0,10	04	Δ	▲

▲ ab Lager / on stock Δ 4 Wochen / 4 weeks x auf Anfrage / upon request

● empfohlen / recommended

o bedingt einsetzbar / alternative recommendation

- nicht geeignet / not suitable

□ unbeschichtete HM-Sorten / uncoated grades

■ beschichtete HM-Sorten / coated grades

■ bestückt/Cermet / brazed/Cermet

Abmessungen in mm

Dimensions in mm

Wendeschneidplatten sind in rechten und linken Klemmhaltern verwendbar.

Indexable inserts can be used in right and left hand toolholders.

P	○	●
M	●	●
K	●	●
N	●	●
S	●	●
H	-	-

HM-Sorten
Carbide grades

K

Gewindedrehen (außen) Vollprofil

Threading (external) Full profile



Wendeschneidplatte

Indexable insert

264

Metrisches ISO-Gewinde
Metric ISO thread

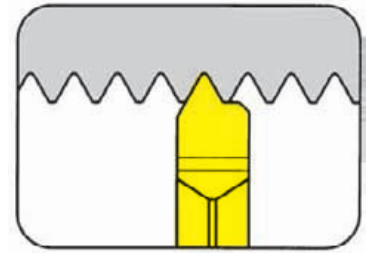

Steigung	Pitch	0,5-1,5 mm
----------	-------	------------

präzisionsgeschliffen
precision ground

für Klemhalter
for Toolholder

Typ H264
Type

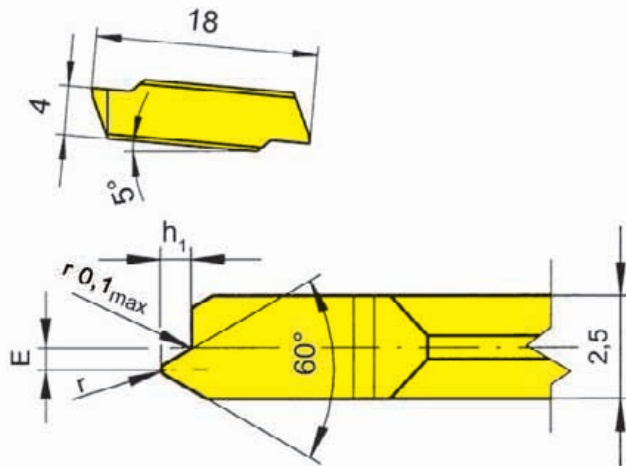

R = rechts wie gezeichnet
R = right hand version shown

L = links spiegelbildlich
L = left hand version

Wechselgenauigkeit
Länge ± 0,015 mm
Indexability length
± 0,015 mm

Bestellnummer Part number	P	E	r	h ₁	Größe Size	TF45
R/L264.0305.02	0,50	0,90	0,07	0,31	03	▲/▲
R/L264.0306.02	0,60	0,90	0,09	0,37	03	△/△
R/L264.0307.02	0,70	0,80	0,10	0,43	03	▲/△
R/L264.0407.02	0,75	0,75	0,11	0,46	03	▲/▲
R/L264.0408.02	0,80	0,70	0,12	0,49	03	▲/△
R/L264.0610.02	1,00	0,60	0,12	0,61	03	▲/▲
R/L264.0712.02	1,25	0,50	0,15	0,77	03	▲/△
R/L264.0915.02	1,50	0,40	0,20	0,92	03	▲/△

▲ ab Lager / on stock △ 4 Wochen / 4 weeks x auf Anfrage / upon request

● empfohlen / recommended

o bedingt einsetzbar / alternative recommendation

- nicht geeignet / not suitable

■ unbeschichtete HM-Sorten / uncoated grades

■ beschichtete HM-Sorten / coated grades

■ bestückt/Cermet / brazed/Cermet

P	•
M	•
K	•
N	•
S	•
H	-

HM-Sorten
Carbide grades

Abmessungen in mm

Dimensions in mm

Ausführung R oder L angeben

State R or L version

Keine Unterlegplatte erforderlich. Sämtliche HORN-Gewindeprofile sind mit einem **KEGELMANTEL-FREISCHLIFF** versehen.
No shims necessary. All HORN thread profiles are manufactured with **full ground radial clearance**.

K

274



**Klemmhalter mit
Schneidplatten**

Stechbreite 0,5 - 7,0 mm

**Toolholder with
Inserts**

Width of groove 0,5 - 7,0 mm

Einstecken und Längsdrehen

Grooving and Side Turning



Klemmhalter
Toolholder
H274/H274...E/
H274...SF/HC274

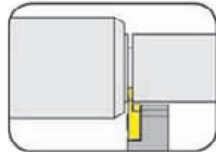

Seite/Page
L3, L6, L29, L46-L47

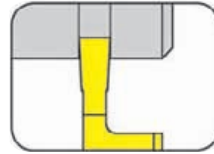

Seite/Page
L15-L17, L32-L34

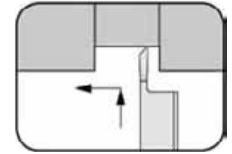

Seite/Page
L53-L54



Seite/Page
L4-L5

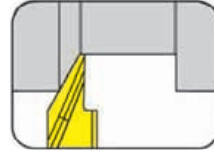

Seite/Page
L18, L35

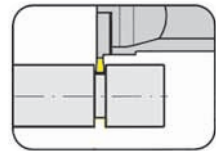

Seite/Page
L8

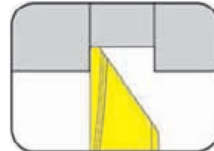

Seite/Page
L19, L36

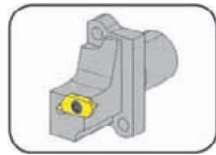

Seite/Page
L9



Seite/Page
L20-L25, L37-L42, L51-L52

Klemmhalter Graf
Toolholder Graf
974



Seite/Page
L7

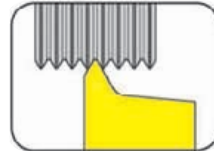

Seite/Page
L26, L43

Einbauhalter
Cartridge
KT274/KTC274

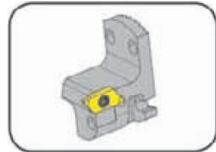

Seite/Page
L10-L11

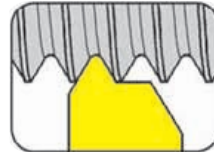

Seite/Page
L27-L28, L44-L45

Einbauhalter Graf
Cartridge Graf
64



Seite/Page
L12

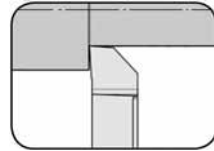

Seite/Page
L48

Wendeschneidplatte
Indexable insert
S274/S274...E/
S274...SF



Seite/Page
L13-L14, L30-L31

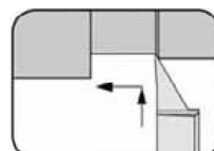

Seite/Page
L49-L50

L

Einstecken und Längsdrehen

Grooving and Side Turning



Klemmhalter

Toolholder

H274

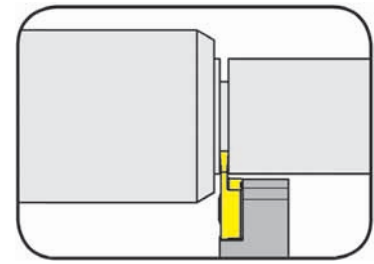

Stechtiefe	Depth of groove	6 mm
Stechbreite	Width of groove	0,5 - 3,0 mm

für Wendeschneidplatte
for Indexable insert

Typ S274
Type

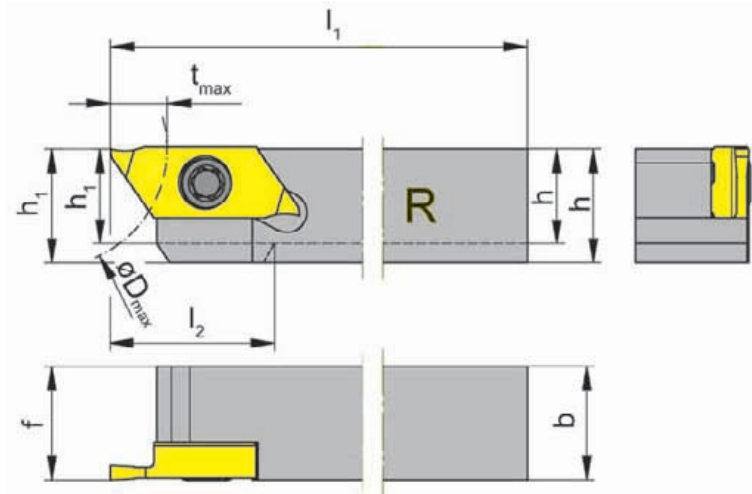

R = rechts wie gezeichnet
R = right hand version shown

L = links spiegelbildlich
L = left hand version

Bestellnummer Part number	h	b	l ₁	l ₂	h ₁	t _{max}	D _{max}	f	Größe Size
R/LH274.0808.04	8	8	100	16	8	6	25	8	04
R/LH274.1010.04	10	10	100	-	10	6	25	10	04
R/LH274.1212.04	12	12	100	-	12	6	25	12	04
R/LH274.1414.04	14	14	100	-	14	6	25	14	04
R/LH274.1616.04	16	16	125	-	16	6	25	16	04
R/LH274.2020.04	20	20	125	-	20	6	25	20	04

Ausführung R oder L angeben
State R or L version

Abmessungen in mm
Dimensions in mm

Weitere Abmessungen auf Anfrage
Further sizes upon request

Das Anzugsdrehmoment der Schrauben finden Sie in den Technischen Hinweisen.
For torque specification of the screw, please see Technical Instructions.

Ersatzteile

Ersatzteile

Klemmhalter Toolholder	Spannschraube Screw	TORX PLUS®-Schlüssel TORX PLUS® Wrench
R/LH274.0808.04	030.350P.0744	T15PQ
R/LH274...	030.3509.T15P	T15PQ



Einstecken und Drehen

Grooving and Turning



Klemmhalter

Toolholder

H274



Stechtiefe	Depth of groove	6 mm
Stechbreite	Width of groove	0,5 - 3,0 mm

für Wendeschneidplatte
for Indexable insert

Typ S274
Type

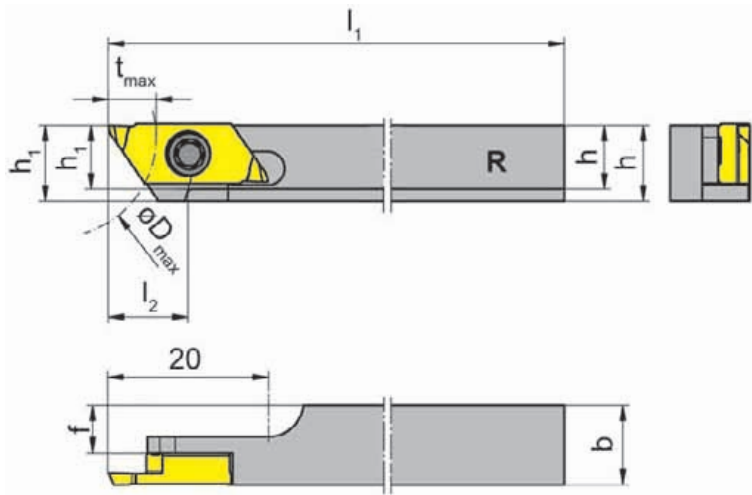

R = rechts wie gezeichnet
R = right hand version shown

Bestellnummer Part number	h	b	l ₁	l ₂	h ₁	t _{max}	D _{max}	f	Größe Size
RH274.0808.6.04	8	8	100	10	9,5	6	25	4	04
RH274.1010.6.04	10	10	100	10	9,5	6	25	6	04
RH274.1212.6.04	12	12	100	10	9,5	6	25	8	04

Abmessungen in mm
Dimensions in mm

Weitere Abmessungen auf Anfrage
Further sizes upon request

Das Anzugsdrehmoment der Schrauben finden Sie in den Technischen Hinweisen.
For torque specification of the screw, please see Technical Instructions.



Ersatzteile

Spare Parts

Klemmhalter Toolholder	Spannschraube Screw	TORX PLUS®-Schlüssel TORX PLUS® Wrench
RH274...	030.350P.0981	T15PQ

Einstecken und Drehen

Grooving and Turning



Klemmhalter

Toolholder

H274

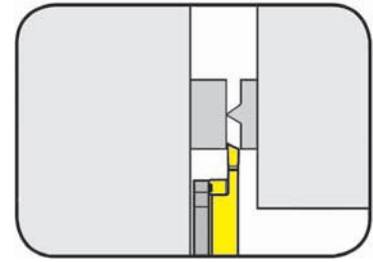

Stechtiefe
Stechbreite

Depth of groove
Width of groove

6 mm
0,5 - 3,0 mm

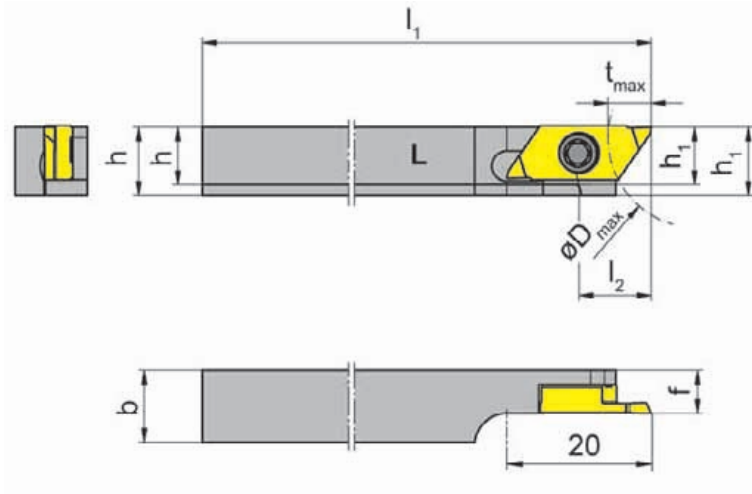

für Wendeschneidplatte
for Indexable insert

Typ S274
Type

L = links wie gezeichnet
L = left hand version shown

Bestellnummer Part number	h	b	l ₁	l ₂	h ₁	t _{max}	D _{max}	f	Größe Size
LH274.0808.6.04.M	8	8	100	10	9,5	6	25	6	04
LH274.1010.6.04.M	10	10	100	10	9,5	6	25	6	04
LH274.1212.6.04.M	12	12	100	10	9,5	6	25	6	04

Abmessungen in mm
Dimensions in mm

Weitere Abmessungen auf Anfrage
Further sizes upon request

Das Anzugsdrehmoment der Schrauben finden Sie in den Technischen Hinweisen.
For torque specification of the screw, please see Technical Instructions.

Ersatzteile

Spare Parts

Klemmhalter Toolholder	Spannschraube Screw	TORX PLUS®-Schlüssel TORX PLUS® Wrench
LH274...	030.350P.0981	T15PQ



Einstechen und Drehen

Grooving and Turning



Klemmhalter

Toolholder

H274

Stechtiefe Stechbreite bis	Depth of groove Width of groove up to	6 mm 7 mm
-------------------------------	--	--------------

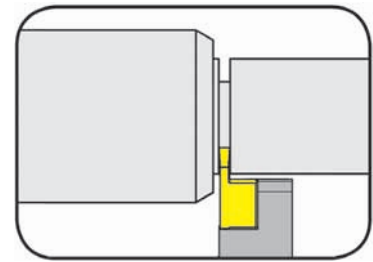

für Wendeschneidplatte
for Indexable insert

Typ S274
Type

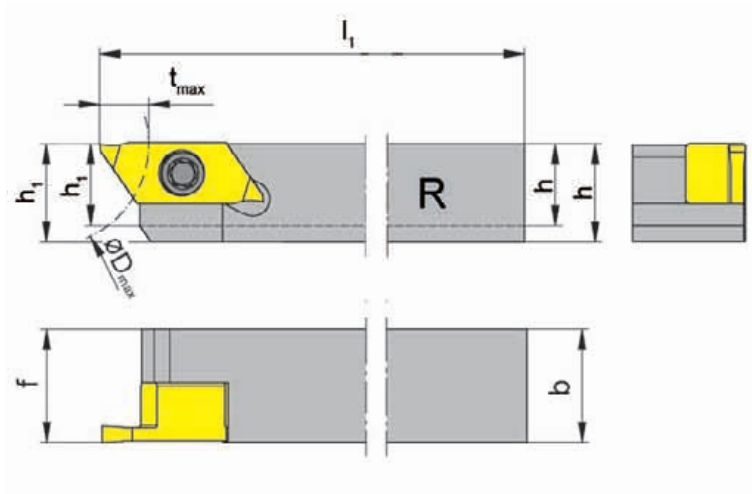

R = rechts wie gezeichnet
R = right hand version shown

L = links spiegelbildlich
L = left hand version

für Sonderbreiten
for special widths

Bestellnummer Part number	h	b	l ₁	h ₁	t _{max}	D _{max}	f	Größe Size
R/LH274.1214.07	12	14	100	12	6	25	14	07
R/LH274.1616.07	16	16	125	16	6	25	16	07

Ausführung R oder L angeben
State R or L version

Abmessungen in mm
Dimensions in mm

Weitere Abmessungen auf Anfrage
Further sizes upon request

Das Anzugsdrehmoment der Schrauben finden Sie in den Technischen Hinweisen.
For torque specification of the screw, please see Technical Instructions.

L

Ersatzteile

Spare Parts

Klemmhalter Toolholder	Spannschraube Screw	TORX PLUS®-Schlüssel TORX PLUS® Wrench
R/LH274...	030.3513.T15P	T15PQ

Einstecken und Längsdrehen

Grooving and Side Turning



Klemmhalter Graf

Toolholder Graf

974

mit innerer Kühlmittelzufuhr
with through coolant supply



Stechtiefe	Depth of groove	6,0 mm
Stechbreite	Width of groove	0,5 - 3,0 mm

für Wendeschneidplatte
for Indexable insert

Typ S274
Type

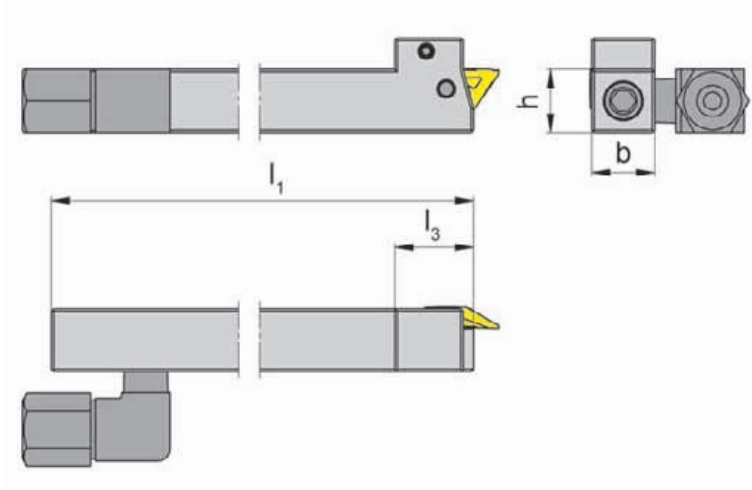

R = rechts wie gezeichnet
R = right hand version shown

L = links spiegelbildlich
L = left hand version

Bestellnummer Part number	h	b	l ₁	l ₃	Größe Size
974.L 1012.04 IK	10	12	100	15	04
974.R 1012.04 IK	10	12	100	15	04
974.L 1212.04 IK	12	12	100	15	04
974.R 1212.04 IK	12	12	100	15	04
974.L 1616.04 IK	16	16	100	15	04
974.R 1616.04 IK	16	16	100	15	04
974.L 2020.04 IK	20	20	100	15	04
974.R 2020.04 IK	20	20	100	15	04

Ausführung R oder L angeben
State R or L version

Abmessungen in mm
Dimensions in mm

Weitere Abmessungen auf Anfrage
Further sizes upon request

Das Anzugsdrehmoment der Schrauben finden Sie in den Technischen Hinweisen.
For torque specification of the screw, please see Technical Instructions.



Einstecken und Längsdrehen (außen)

Grooving and Side Turning (external)



Klemmhalter

Toolholder

HC274

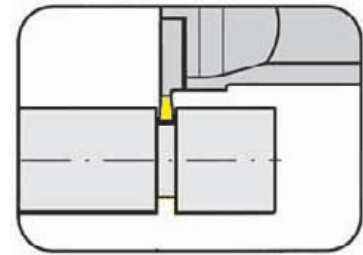

Stechtiefe bis	Depth of groove up to	4 mm
Stechbreite bis	Width of groove up to	3 mm

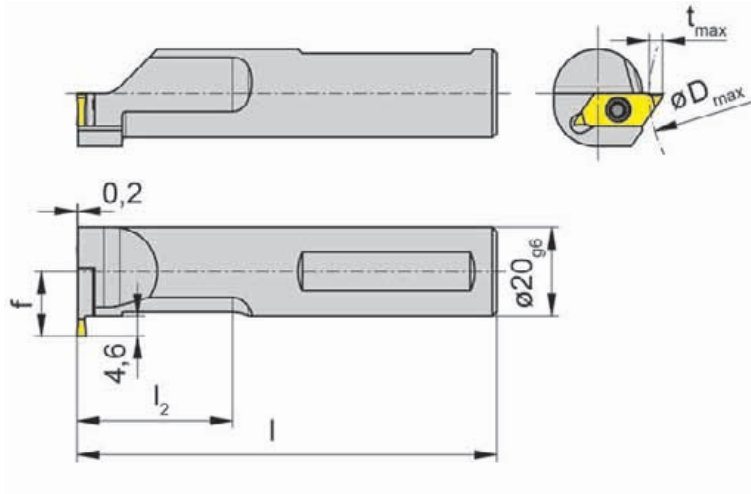

für Wendeschneidplatte
for Indexable insert

Typ LS274...
Type

Stechtiefe in Abhängigkeit des
Bohrungs-Ø
Depth of groove in relation to bore Ø

D _{max}	t _{max}
40	2,0
60	3,0
120	3,5

TRAUB TNL18 / 32
TRAUB TNL18 / 32

R = rechts wie gezeichnet
R = right hand version shown

Bestellnummer Part number	l	t _{max}	l ₂	f	Größe Size
RHC274.0020.1.04	95	4	35	14,6	04

Abmessungen in mm
Dimensions in mm

Weitere Abmessungen auf Anfrage
Further sizes upon request

Bestellhinweis:

Linke Wendeschneidplatte für rechten Klemmhalter verwenden.

Ordering note:

Use left hand insert in right hand toolholder.

Das Anzugsdrehmoment der Schrauben finden Sie in den Technischen Hinweisen.

For torque specification of the screw, please see Technical Instructions.

Ersatzteile

Spare Parts

Klemmhalter Toolholder	Schraube Screw	TORX PLUS®-Schlüssel TORX PLUS® Wrench
RHC274.0020.1.04	030.3509.T15P	T15PQ

Einstecken und Drehen

Grooving and Turning



Klemmhalter

Toolholder

H274

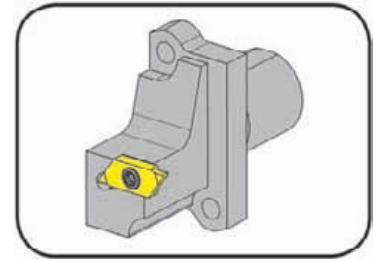

Stechtiefe bis
Stechbreite bis

Depth of groove up to
Width of groove up to

6 mm
7 mm

Lochbild 13,7 x 37,6 mm
Hole pattern 13,7 x 37,6 mm

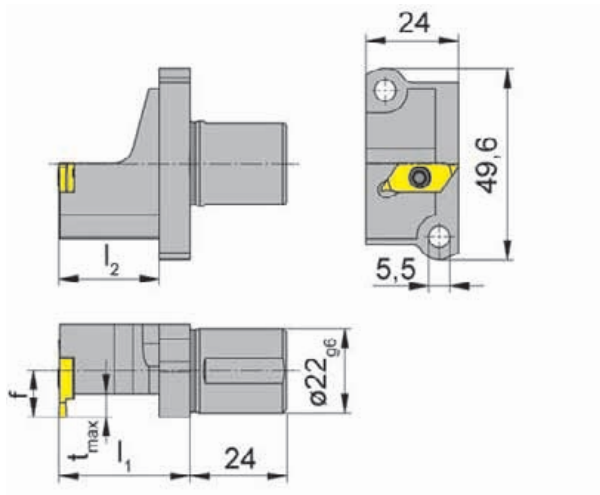

für Wendeschneidplatte
for Indexable insert

Typ S274
Type

für Star
Langdrehautomaten
for Swiss type machines Star

R = rechts wie gezeichnet
R = right hand version shown

L = links spiegelbildlich
L = left hand version

Bestellnummer Part number	f	l ₁	t _{max}	l ₂	Größe Size
R/LH274.A022.09.04	9	34	6	26	04
R/LH274.A022.12.04	12	34	6	26	04
R/LH274.A022.16.04	16	34	6	26	04
R/LH274.A022.09.07	9	34	6	26	07
R/LH274.A022.12.07	12	34	6	26	07

Ausführung R oder L angeben
State R or L version

Abmessungen in mm
Dimensions in mm

Weitere Abmessungen auf Anfrage
Further sizes upon request

Bestellhinweis:

Rechte WSP in linken, linke WSP in rechten Klemmhaltern verwenden.

Ordering note:

Use right hand inserts in left hand toolholders and left hand inserts in right hand toolholders

Das Anzugsdrehmoment der Schrauben finden Sie in den Technischen Hinweisen.

For torque specification of the screw, please see Technical Instructions.

Ersatzteile

Spare Parts

Klemmhalter Toolholder	Spannschraube Screw	TORX PLUS®-Schlüssel TORX PLUS® Wrench
R/LH274...	030.3513.T15P	T15PQ



Einstecken und Längsdrehen

Grooving and Side Turning



Einbauhalter

Cartridge

KT274

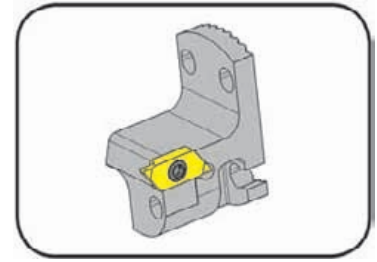

Stechtiefe bis
Stechbreite

Depth of groove up to
Width of groove

6 mm
0,5 - 3,0 mm

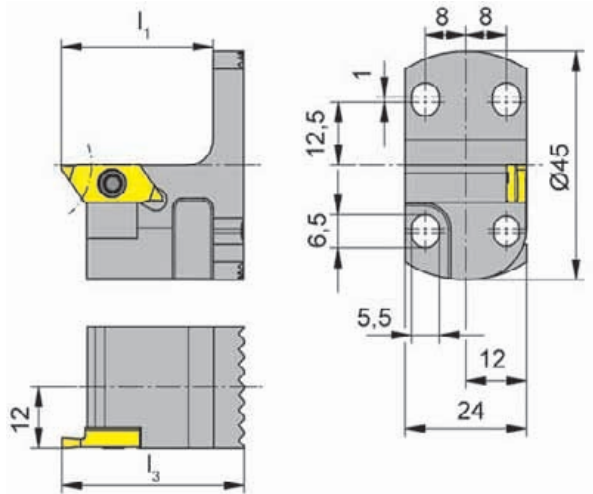

R = rechts wie gezeichnet
R = right hand version shown

L = links spiegelbildlich
L = left hand version

für Wendeschneidplatte
for Indexable insert

Typ S274
Type

Bestellnummer Part number	l_3	l_1	Größe Size
R/LKT274.2445.04	36	30	04

Ausführung R oder L angeben
State R or L version

Abmessungen in mm
Dimensions in mm

Weitere Abmessungen auf Anfrage
Further sizes upon request

Das Anzugsdrehmoment der Schrauben finden Sie in den Technischen Hinweisen.
For torque specification of the screw, please see Technical Instructions.

L

Ersatzteile

Spare Parts

Einbauhalter Cartridge	Schraube Screw	TORX PLUS®-Schlüssel TORX PLUS® Wrench
R/LKT274.2445.04	030.3509.T15P	T15PQ

Einstecken und Längsdrehen

Grooving and Side Turning



Einbauhalter

Cartridge

KTC274

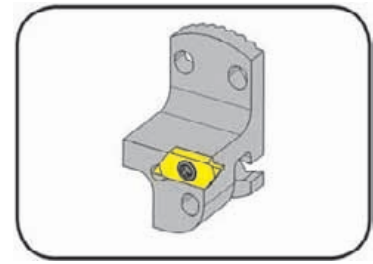

Stechtiefe bis
Stechbreite

Depth of groove up to
Width of groove

6 mm
0,5 - 3,0 mm

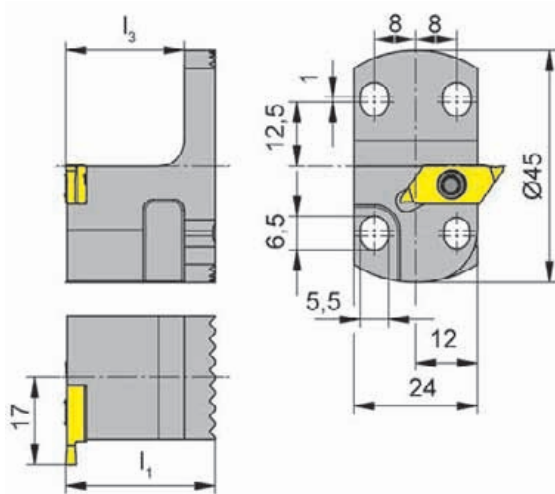

für Wendeschneidplatte
for Indexable insert

Typ S274
Type

R = rechts wie gezeichnet
R = right hand version shown

Bestellnummer Part number	l_1	l_3	Größe Size
RKTC274.2445.04	29	23	04

Weitere Abmessungen auf Anfrage
Further sizes upon request

Abmessungen in mm
Dimensions in mm

Bestellhinweis:

Linke Wendeschneidplatte für rechten Klemmhalter verwenden.

Ordering note:

Use left hand insert in right hand toolholder.

Das Anzugsdrehmoment der Schrauben finden Sie in den Technischen Hinweisen.

For torque specification of the screw, please see Technical Instructions.

Ersatzteile

Spare Parts

Einbauhalter Cartridge	Schraube Screw	TORX PLUS®-Schlüssel TORX PLUS® Wrench
RKTC274.2445.04	030.3509.T15P	T15PQ



Einbauhalter Graf

Cartridge Graf

76

mit innerer Kühlmittelzufuhr
with through coolant supply



Stechtiefe
Stechbreite

Depth of groove
Width of groove

6 mm
0,5 - 3,0 mm

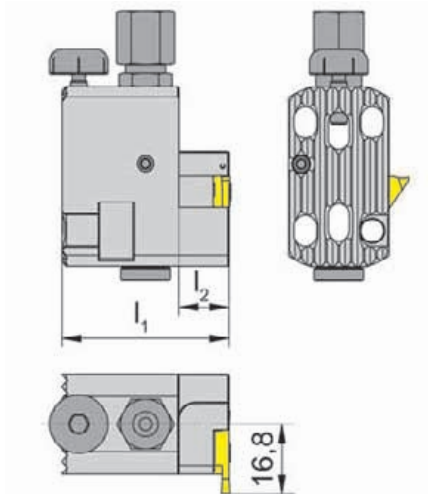

für Wendeschneidplatte
for Indexable insert

Typ S274
Type

R = rechts wie gezeichnet
R = right hand version shown

Bestellnummer Part number	l_1	l_2	Größe Size
R76IK	40	12	04

Weitere Abmessungen auf Anfrage
Further sizes upon request

Abmessungen in mm
Dimensions in mm

Bestellhinweis:

Linke Wendeschneidplatte für rechten Klemmhalter verwenden.

Ordering note:

Use left hand insert in right hand toolholder.

Das Anzugsdrehmoment der Schrauben finden Sie in den Technischen Hinweisen.

For torque specification of the screw, please see Technical Instructions.

Ersatzteile

Spare Parts

Einbauhalter Graf Cartridge Graf	Höhenverstellungsschraube Screw to adjust the height	Kühlmittelanschluss Coolant supply	Schraube Screw	TORX PLUS®-Schlüssel TORX PLUS® Wrench
R76IK	002.00.69	004.00.19	030.3509.T15P	T15PQ

Einstechen und Längsdrehen

Grooving and Side Turning



Wendeschneidplatte

Indexable insert

S274

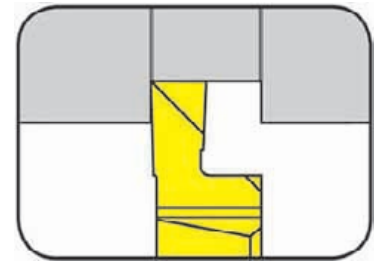

Stechtiefe bis Stechbreite	Depth of groove up to Width of groove	4,5 mm 1,5-3 mm
-------------------------------	--	--------------------

präzisionsgeschliffen
precision ground

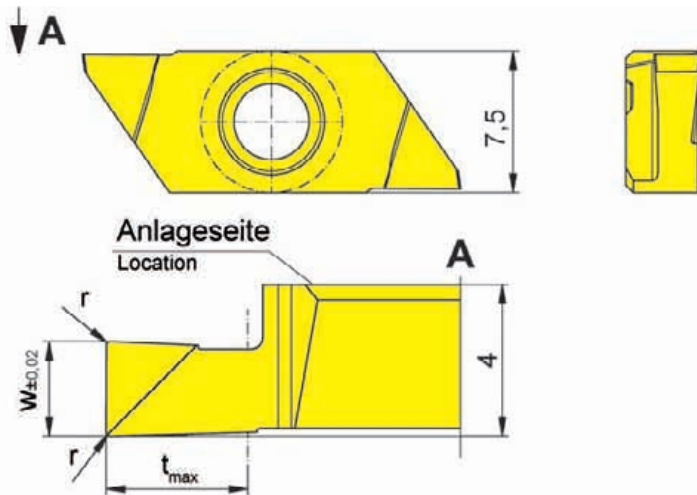

R = rechts wie gezeichnet
R = right hand version shown

L = links spiegelbildlich
L = left hand version

für Klemhalter
for Toolholder

Typ H274
Type KT274
KTC274
974
R76
H274KM
HC274KM

Wechselgenauigkeit
Länge ± 0,015 mm
Indexability length
± 0,015 mm

Bestellnummer Part number	w	r	t _{max}	Größe Size	TH35
R/LS274.0150.P0	1,5	0,05	2,25	04	▲/▲
R/LS274.0200.P0	2,0	0,05	3,00	04	▲/Δ
R/LS274.0250.P0	2,5	0,10	3,75	04	▲/▲
R/LS274.0300.P0	3,0	0,10	4,50	04	▲/Δ

▲ ab Lager / on stock Δ 4 Wochen / 4 weeks x auf Anfrage / upon request

● empfohlen / recommended

o bedingt einsetzbar / alternative recommendation

- nicht geeignet / not suitable

■ unbeschichtete HM-Sorten / uncoated grades

■ beschichtete HM-Sorten / coated grades

■ bestückt/Cermet / brazed/Cermet

Abmessungen in mm

Dimensions in mm

Ausführung R oder L angeben

State R or L version

P	•
M	•
K	•
N	•
S	•
H	-

HM-Sorten
Carbide grades



Einstechen und Längsdrehen

Grooving and Side Turning



Wendeschneidplatte

Indexable insert

S274

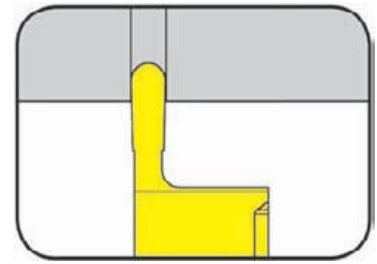

Stechtiefe bis Vollradius	Depth of groove up to Full radius	4 mm 0,25-1 mm
---------------------------	-----------------------------------	-------------------

präzisionsgeschliffen
precision ground

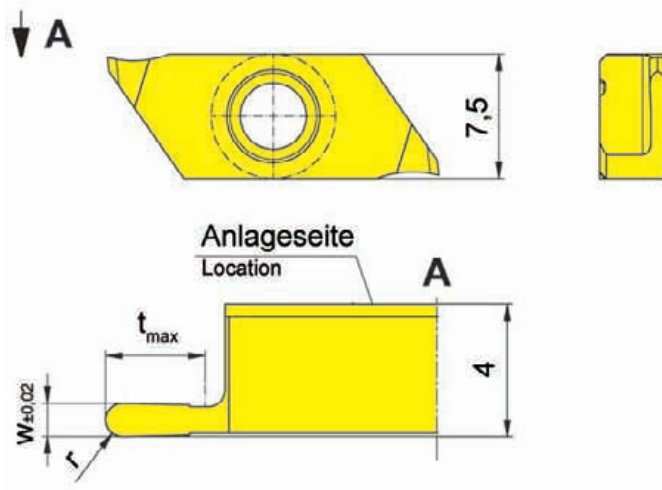

für Klemmhalter
for Toolholder

Typ H274
Type KT274
KTC274
974
R76
H274KM
HC274KM

Wechselgenauigkeit
Länge ± 0,015 mm
Indexability length
± 0,015 mm

R = rechts wie gezeichnet
R = right hand version shown

L = links spiegelbildlich
L = left hand version

Bestellnummer Part number	w	t _{max}	r	Größe Size	TH35
R/LS274.0205.01.10	0,5	1,5	0,25	04	▲/Δ
R/LS274.0510.03.10	1,0	3,0	0,50	04	▲/▲
R/LS274.1020.04.10	2,0	4,0	1,00	04	▲/Δ

▲ ab Lager / on stock Δ 4 Wochen / 4 weeks x auf Anfrage / upon request

● empfohlen / recommended

o bedingt einsetzbar / alternative recommendation

- nicht geeignet / not suitable

■ unbeschichtete HM-Sorten / uncoated grades

■ beschichtete HM-Sorten / coated grades

■ bestückt/Cermet / brazed/Cermet

Abmessungen in mm

Dimensions in mm

Ausführung R oder L angeben

State R or L version

P	•
M	•
K	•
N	•
S	•
H	-

HM-Sorten
Carbide grades



Einstechen und Abstechen

Grooving and Parting Off



Wendeschneidplatte

Indexable insert

S274

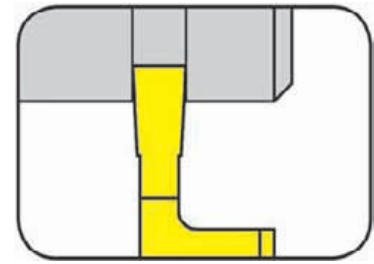

Stechtiefe bis Stechbreite	Depth of groove up to Width of groove	6 mm 0,5-2 mm
-------------------------------	--	------------------

präzisionsgeschliffen
precision ground

für Klemhalter
for Toolholder

Typ H274
Type KT274
KTC274
974
R76
H274KM
HC274KM

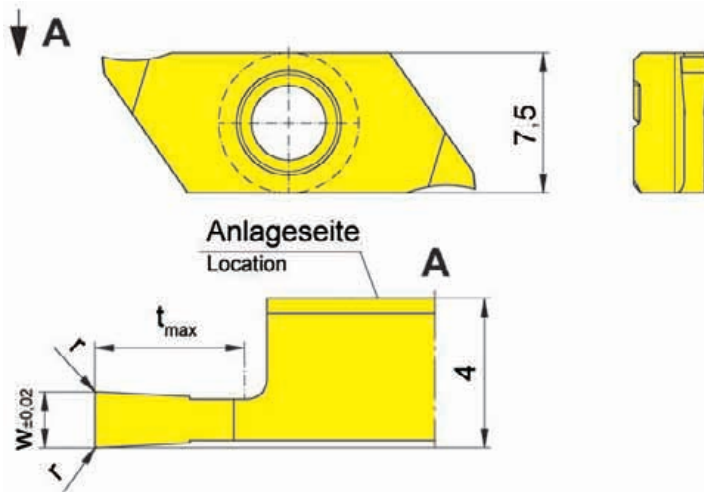

R = rechts wie gezeichnet
R = right hand version shown

L = links spiegelbildlich
L = left hand version

Wechselgenauigkeit
Länge ± 0,015 mm
Indexability length
± 0,015 mm

Bestellnummer Part number	w	r	t _{max}	Größe Size	TH35
R/LS274.0050.01.10	0,5	0,05	1,5	04	▲/▲
R/LS274.0070.02.10	0,7	0,05	2,0	04	▲/Δ
R/LS274.0080.03.10	0,8	0,05	3,0	04	▲/▲
R/LS274.0100.03.10	1,0	0,05	3,0	04	▲/▲
R/LS274.0120.03.10	1,2	0,05	3,0	04	▲/Δ
R/LS274.0150.04.10	1,5	0,05	4,0	04	▲/▲
R/LS274.0150.06.10	1,5	0,05	6,0	04	▲/▲
R/LS274.0200.04.10	2,0	0,05	4,0	04	▲/▲
R/LS274.0200.06.10	2,0	0,05	6,0	04	▲/▲

▲ ab Lager / on stock Δ 4 Wochen / 4 weeks x auf Anfrage / upon request

● empfohlen / recommended

o bedingt einsetzbar / alternative recommendation

- nicht geeignet / not suitable

■ unbeschichtete HM-Sorten / uncoated grades

■ beschichtete HM-Sorten / coated grades

■ bestückt/Cermet / brazed/Cermet

Abmessungen in mm

Dimensions in mm

Ausführung R oder L angeben

State R or L version

P	•
M	•
K	•
N	•
S	•
H	-

HM-Sorten
Carbide grades



Einstechen und Abstechen

Grooving and Parting Off



Wendeschneidplatte

Indexable insert

S274

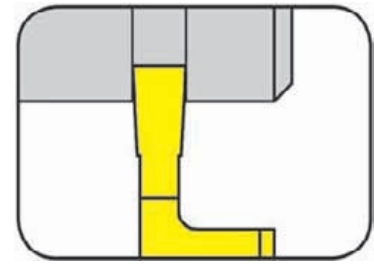

Stechtiefe bis Stechbreite	Depth of groove up to Width of groove	6 mm 0,5-2 mm
-------------------------------	--	------------------

präzisionsgeschliffen
precision ground

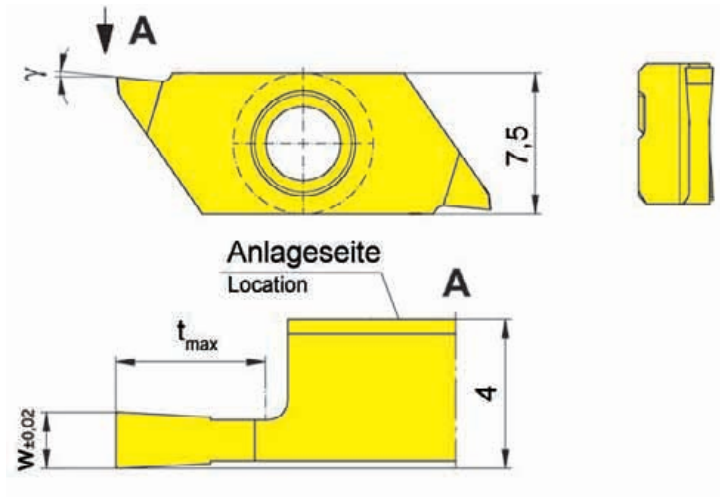

für Klemhalter
for Toolholder

Typ H274
Type KT274
KTC274
974
R76
H274KM
HC274KM

Wechselgenauigkeit
Länge ± 0,015 mm
Indexability length
± 0,015 mm

R = rechts wie gezeichnet
R = right hand version shown

L = links spiegelbildlich
L = left hand version

Bestellnummer Part number	w	t _{max}	γ	Größe Size	TH35
R/LS274.0050.01.20	0,5	1,5	5°	04	▲▲
R/LS274.0070.02.20	0,7	2,0	5°	04	▲▲
R/LS274.0080.03.20	0,8	3,0	5°	04	▲▲
R/LS274.0100.03.20	1,0	3,0	5°	04	▲▲
R/LS274.0120.03.20	1,2	3,0	5°	04	▲▲
R/LS274.0150.04.20	1,5	4,0	5°	04	▲▲
R/LS274.0150.06.20	1,5	6,0	5°	04	▲▲
R/LS274.0200.04.20	2,0	4,0	5°	04	▲▲
R/LS274.0200.06.20	2,0	6,0	5°	04	▲▲

▲ ab Lager / on stock Δ 4 Wochen / 4 weeks x auf Anfrage / upon request

● empfohlen / recommended

o bedingt einsetzbar / alternative recommendation

- nicht geeignet / not suitable

■ unbeschichtete HM-Sorten / uncoated grades

■ beschichtete HM-Sorten / coated grades

■ bestückt/Cermet / brazed/Cermet

Abmessungen in mm

Dimensions in mm

Ausführung R oder L angeben

State R or L version

P	•
M	•
K	•
N	•
S	•
H	-

HM-Sorten
Carbide grades

L

Einstechen und Abstechen

Grooving and Parting Off



Wendeschneidplatte

Indexable insert

S274

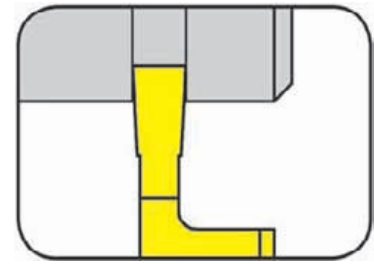

Stechtiefe bis Stechbreite	Depth of groove up to Width of groove	6 mm 0,5-2 mm
-------------------------------	--	------------------

präzisionsgeschliffen
precision ground

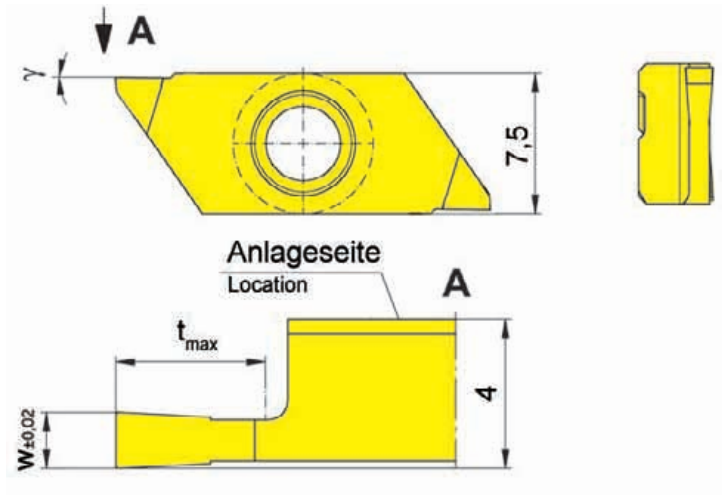

für Klemhalter
for Toolholder

Typ H274
Type KT274
KTC274
974
R76
H274KM
HC274KM

Wechselgenauigkeit
Länge ± 0,015 mm
Indexability length
± 0,015 mm

R = rechts wie gezeichnet
R = right hand version shown

L = links spiegelbildlich
L = left hand version

Bestellnummer Part number	w	t _{max}	γ	Größe Size	TH35
R/LS274.0050.01.M0	0,5	1,5	0°	04	▲▲
R/LS274.0070.02.M0	0,7	2,0	0°	04	▲▲
R/LS274.0080.03.M0	0,8	3,0	0°	04	▲▲
R/LS274.0100.03.M0	1,0	3,0	0°	04	▲▲
R/LS274.0120.03.M0	1,2	3,0	0°	04	▲▲
R/LS274.0150.04.M0	1,5	4,0	0°	04	▲▲
R/LS274.0150.06.M0	1,5	6,0	0°	04	▲▲
R/LS274.0200.04.M0	2,0	4,0	0°	04	▲▲
R/LS274.0200.06.M0	2,0	6,0	0°	04	▲▲

▲ ab Lager / on stock Δ 4 Wochen / 4 weeks x auf Anfrage / upon request

● empfohlen / recommended

o bedingt einsetzbar / alternative recommendation

- nicht geeignet / not suitable

■ unbeschichtete HM-Sorten / uncoated grades

■ beschichtete HM-Sorten / coated grades

■ bestückt/Cermet / brazed/Cermet

Abmessungen in mm

Dimensions in mm

Ausführung R oder L angeben

State R or L version

P	•
M	•
K	•
N	•
S	•
H	-

HM-Sorten
Carbide grades



Rückwärtsdrehen (außen)

Backturning (external)



Wendeschneidplatte

Indexable insert

S274

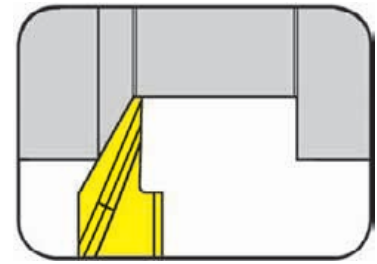

Schnitttiefe bis	Depth of cut up to	6 mm
------------------	--------------------	------

präzisionsgeschliffen
precision ground

für Klemhalter
for Toolholder

Typ H274
Type KT274
KTC274
974
R76
H274KM
HC274KM

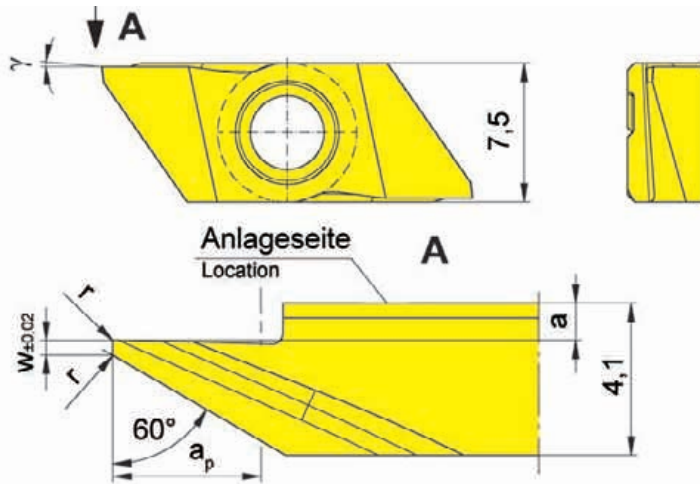

R = rechts wie gezeichnet
R = right hand version shown

L = links spiegelbildlich
L = left hand version

Wechselgenauigkeit
Länge ± 0,015 mm
Indexability length
± 0,015 mm

Bestellnummer Part number	w	r	a	γ	a _p	Größe Size	K10	TH35
R/LS274.0460.04.10	0,4	0,05	1,00	15°	4	04	▲/▲	▲/▲
R/LS274.0460.04.M0	0,4	0,05	1,00	0°	4	04	▲/Δ	Δ/Δ
R/LS274.0560.06.11	0,5	0,10	0,05	15°	6	04	▲/▲	▲/▲
R/LS274.0060.04.10	-	0,05	1,00	15°	4	04	▲/▲	▲/▲

▲ ab Lager / on stock Δ 4 Wochen / 4 weeks x auf Anfrage / upon request

● empfohlen / recommended

○ bedingt einsetzbar / alternative recommendation

- nicht geeignet / not suitable

■ unbeschichtete HM-Sorten / uncoated grades

■ beschichtete HM-Sorten / coated grades

■ bestückt/Cermet / brazed/Cermet

Abmessungen in mm

Dimensions in mm

Ausführung R oder L angeben

State R or L version

γ = Spanwinkel

γ = rake angle

P	●	●
M	○	●
K	●	●
N	●	●
S	○	●
H	-	-

HM-Sorten
Carbide grades

L

Längsdrehen

Side Turning



Wendeschneidplatte

Indexable insert

S274

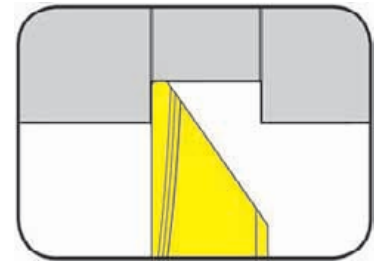

Schnitttiefe bis Depth of cut up to 6 mm

präzisionsgeschliffen
precision ground

für Klemhalter
for Toolholder

Typ H274
Type KT274
 KTC274
 974
 R76
 H274KM
 HC274KM

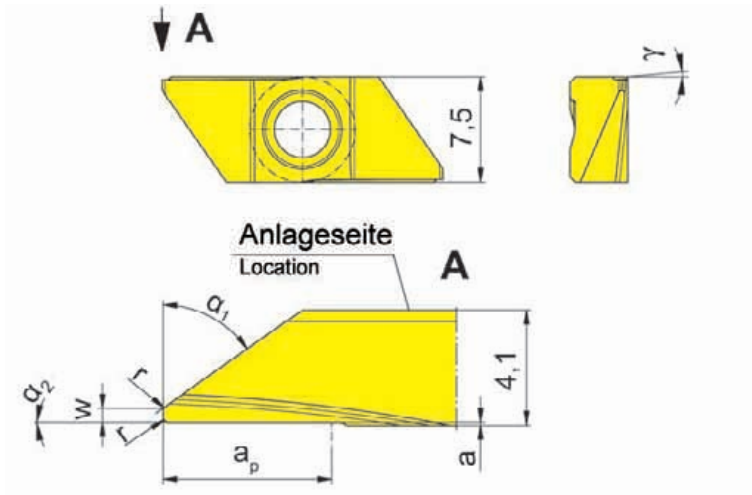

R = rechts wie gezeichnet
R = right hand version shown

L = links spiegelbildlich
L = left hand version

Wechselgenauigkeit
Länge ± 0,015 mm
Indexability length
± 0,015 mm

Bestellnummer Part number	w	r	α_1	a	γ	a_p	α_2	Größe Size	TH35
R/LS274.0035.04.20	-	0,05	35°	0,1	5°	4	0°	04	▲▲
R/LS274.0235.04.20	0,2	-	35°	0,1	5°	4	0°	04	▲▲
R/LS274.0535.06.20	0,5	0,20	35°	0,1	5°	6	0°	04	▲▲
R/LS274.0055.04.20	-	0,05	55°	0,1	5°	4	0°	04	▲▲
R/LS274.0255.04.20	0,2	-	55°	0,1	5°	4	0°	04	▲▲
R/LS274.0555.06.20	0,5	0,20	55°	0,1	5°	6	0°	04	▲▲

▲ ab Lager / on stock Δ 4 Wochen / 4 weeks x auf Anfrage / upon request

● empfohlen / recommended

o bedingt einsetzbar / alternative recommendation

- nicht geeignet / not suitable

■ unbeschichtete HM-Sorten / uncoated grades

■ beschichtete HM-Sorten / coated grades

■ bestückt/Cermet / brazed/Cermet

Abmessungen in mm

Dimensions in mm

Ausführung R oder L angeben

State R or L version

P	•
M	•
K	•
N	•
S	•
H	-

HM-Sorten
Carbide grades



Abstechen

Parting Off



Wendeschneidplatte

Indexable insert

S274

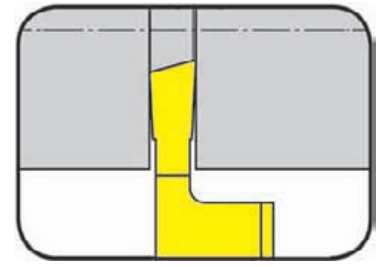

Stechtiefe bis Stechbreite	Depth of groove up to Width of groove	6 mm 0,8-2 mm
-------------------------------	--	------------------

präzisionsgeschliffen
precision ground

für Klemhalter
for Toolholder

Typ H274
Type KT274
KTC274
974
R76
H274KM
HC274KM

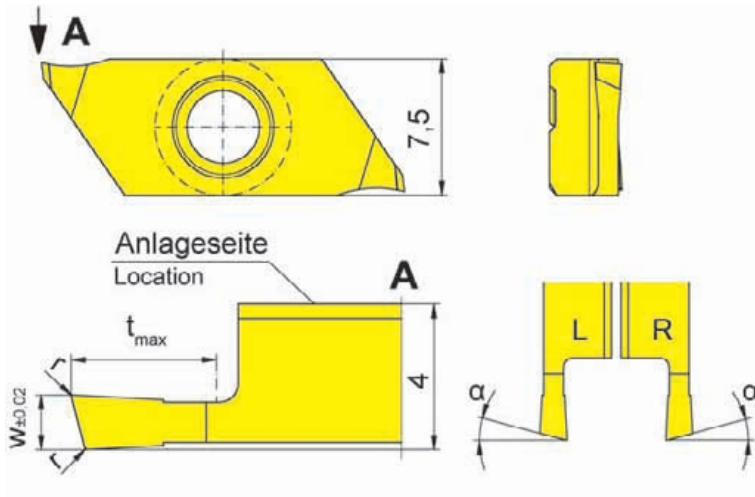

R = rechts wie gezeichnet
R = right hand version shown

L = links spiegelbildlich
L = left hand version

Wechselgenauigkeit
Länge ± 0,015 mm
Indexability length
± 0,015 mm

Bestellnummer Part number	w	r	t _{max}	α	Größe Size	TH35
R/LS274.1508.03.10	0,8	0,05	3	15°	04	▲/Δ
R/LS274.1510.03.10	1,0	0,05	3	15°	04	▲/▲
R/LS274.1515.04.10	1,5	0,05	4	15°	04	▲/▲
R/LS274.1520.06.10	2,0	0,05	6	15°	04	▲/▲

▲ ab Lager / on stock Δ 4 Wochen / 4 weeks x auf Anfrage / upon request

● empfohlen / recommended

o bedingt einsetzbar / alternative recommendation

- nicht geeignet / not suitable

■ unbeschichtete HM-Sorten / uncoated grades

■ beschichtete HM-Sorten / coated grades

■ bestückt/Cermet / brazed/Cermet

Abmessungen in mm

Dimensions in mm

Ausführung R oder L angeben

State R or L version

Hinweis:

t_{max} 6 mm nur bei Werkstück-Ø ≤ 25 mm erreichbar.

Note:

t_{max} 6 mm can be reached only with workpiece Ø ≤ 25 mm.

P	•
M	•
K	•
N	•
S	•
H	-

HM-Sorten
Carbide grades



Abstechen

Parting Off



Wendeschneidplatte

Indexable insert

S274

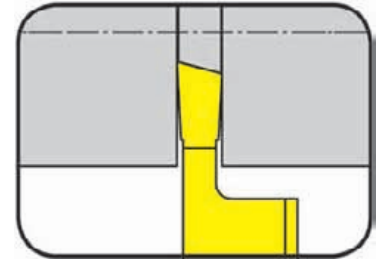

Stechtiefe bis Stechbreite	Depth of groove up to Width of groove	6 mm 0,8-2 mm
-------------------------------	--	------------------

präzisionsgeschliffen
precision ground

für Klemhalter
for Toolholder

Typ H274
Type KT274
KTC274
974
R76
H274KM
HC274KM

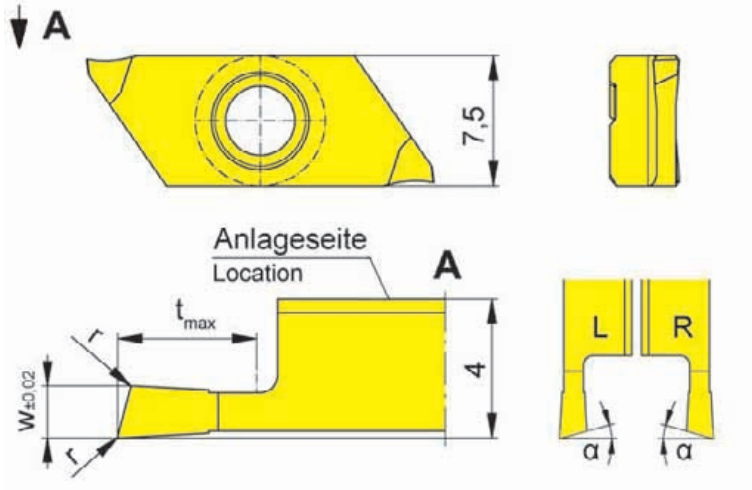

R = rechts wie gezeichnet
R = right hand version shown

L = links spiegelbildlich
L = left hand version

Wechselgenauigkeit
Länge ± 0,015 mm
Indexability length
± 0,015 mm

Bestellnummer Part number	w	r	t _{max}	α	Größe Size	TH35
LS274.1508.03.10R	0,8	0,05	3	15°	04	▲
LS274.1510.03.10R	1,0	0,05	3	15°	04	▲
LS274.1515.04.10R	1,5	0,05	4	15°	04	▲
LS274.1520.06.10R	2,0	0,05	6	15°	04	▲
RS274.1508.03.10L	0,8	0,05	3	15°	04	△
RS274.1510.03.10L	1,0	0,05	3	15°	04	△
RS274.1515.04.10L	1,5	0,05	4	15°	04	△
RS274.1520.06.10L	2,0	0,05	6	15°	04	△

- ▲ ab Lager / on stock △ 4 Wochen / 4 weeks x auf Anfrage / upon request
- empfohlen / recommended
- o bedingt einsetzbar / alternative recommendation
- nicht geeignet / not suitable
- unbeschichtete HM-Sorten / uncoated grades
- beschichtete HM-Sorten / coated grades
- bestückt/Cermet / brazed/Cermet

P	•
M	•
K	•
N	•
S	•
H	-

HM-Sorten
Carbide grades

Abmessungen in mm
Dimensions in mm

Ausführung R oder L angeben
State R or L version

Hinweis:

t_{max} 6 mm nur bei Werkstück-Ø ≤ 25 mm erreichbar.

Note:

t_{max} 6 mm can be reached only with workpiece Ø ≤ 25 mm.



Abstechen

Parting Off



Wendeschneidplatte

Indexable insert

S274

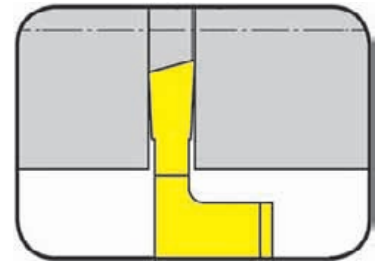

Stechtiefe bis Stechbreite	Depth of groove up to Width of groove	6 mm 1,5-2 mm
-------------------------------	--	------------------

präzisionsgeschliffen
precision ground

für Klemmhalter
for Toolholder

Typ H274
Type KT274
KTC274
974
R76
H274KM
HC274KM

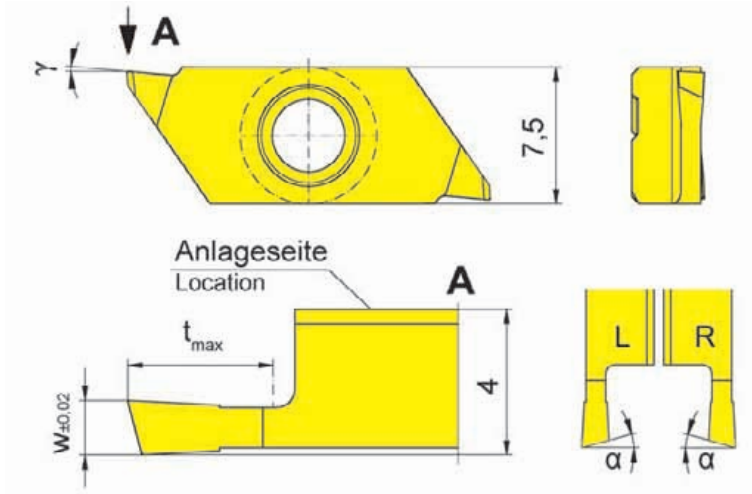

R = rechts wie gezeichnet
R = right hand version shown

L = links spiegelbildlich
L = left hand version

Wechselgenauigkeit
Länge ± 0,015 mm
Indexability length
± 0,015 mm

Bestellnummer Part number	w	t _{max}	α	γ	Größe Size	TH35
R/LS274.1515.04.20	1,5	4	15°	5°	04	▲▲▲
R/LS274.1520.06.20	2,0	6	15°	5°	04	▲▲▲

- ▲ ab Lager / on stock Δ 4 Wochen / 4 weeks x auf Anfrage / upon request
- empfohlen / recommended
- o bedingt einsetzbar / alternative recommendation
- nicht geeignet / not suitable
- unbeschichtete HM-Sorten / uncoated grades
- beschichtete HM-Sorten / coated grades
- bestückt/Cermet / brazed/Cermet

P	•
M	•
K	•
N	•
S	•
H	-

Abmessungen in mm
Dimensions in mm

HM-Sorten
Carbide grades

Ausführung R oder L angeben
State R or L version

Hinweis:

t_{max} 6 mm nur bei Werkstück-Ø ≤ 25 mm erreichbar.

Note:

t_{max} 6 mm can be reached only with workpiece Ø ≤ 25 mm.



Abstechen

Parting Off



Wendeschneidplatte

Indexable insert

S274

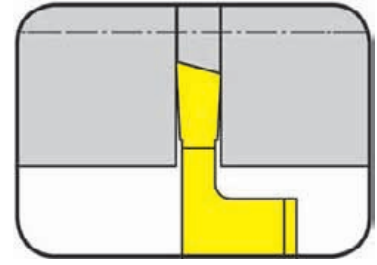

Stechtiefe bis Stechbreite	Depth of groove up to Width of groove	6 mm 1,5-2 mm
-------------------------------	--	------------------

präzisionsgeschliffen
precision ground

für Klemhalter
for Toolholder

Typ H274
Type KT274
KTC274
974
R76
H274KM
HC274KM

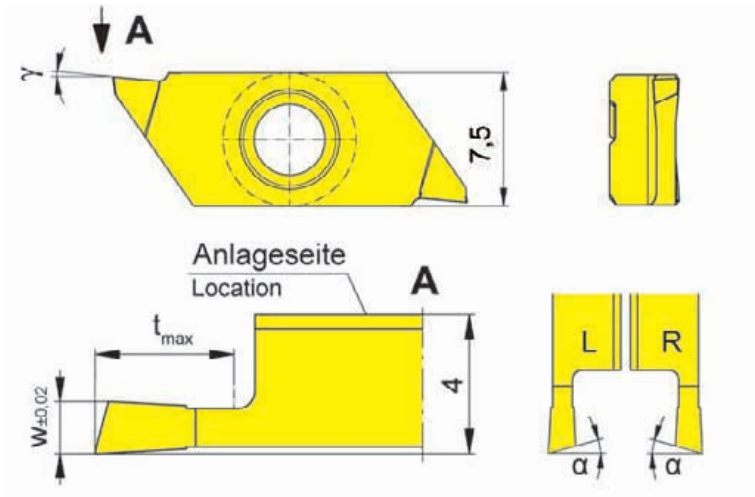

R = rechts wie gezeichnet
R = right hand version shown

L = links spiegelbildlich
L = left hand version

Wechselgenauigkeit
Länge ± 0,015 mm
Indexability length
± 0,015 mm

Bestellnummer Part number	w	t _{max}	α	γ	Größe Size	TH35
LS274.1515.04.20R	1,5	4	15°	5°	04	▲
LS274.1520.06.20R	2,0	6	15°	5°	04	▲
RS274.1515.04.20L	1,5	4	15°	5°	04	▲
RS274.1520.06.20L	2,0	6	15°	5°	04	▲

▲ ab Lager / on stock Δ 4 Wochen / 4 weeks x auf Anfrage / upon request

● empfohlen / recommended

o bedingt einsetzbar / alternative recommendation

- nicht geeignet / not suitable

■ unbeschichtete HM-Sorten / uncoated grades

■ beschichtete HM-Sorten / coated grades

■ bestückt/Cermet / brazed/Cermet

Abmessungen in mm

Dimensions in mm

Ausführung R oder L angeben

State R or L version

Hinweis:

t_{max} 6 mm nur bei Werkstück-Ø ≤ 25 mm erreichbar.

Note:

t_{max} 6 mm can be reached only with workpiece Ø ≤ 25 mm.

P	•
M	•
K	•
N	•
S	•
H	-

HM-Sorten
Carbide grades



Wendeschneidplatte

Indexable insert

S274



Stechtiefe bis Stechbreite	Depth of groove up to Width of groove	6 mm 0,8-2 mm
----------------------------	---------------------------------------	------------------

präzisionsgeschliffen
precision ground

für Klemhalter
for Toolholder

Typ H274
Type KT274
KTC274
974
R76
H274KM
HC274KM

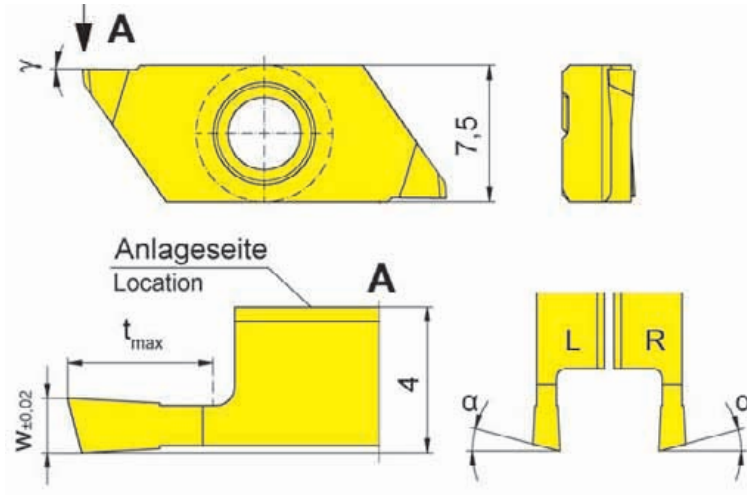

R = rechts wie gezeichnet
R = right hand version shown

L = links spiegelbildlich
L = left hand version

Wechselgenauigkeit
Länge $\pm 0,015$ mm
Indexability length
 $\pm 0,015$ mm

Bestellnummer Part number	w	t _{max}	α	γ	Größe Size	TH35
R/LS274.1508.03.M0	0,8	3	15°	0°	04	▲▲
R/LS274.1510.03.M0	1,0	3	15°	0°	04	▲▲
R/LS274.1515.04.M0	1,5	4	15°	0°	04	▲▲
R/LS274.1520.06.M0	2,0	6	15°	0°	04	▲▲

▲ ab Lager / on stock Δ 4 Wochen / 4 weeks x auf Anfrage / upon request

● empfohlen / recommended

o bedingt einsetzbar / alternative recommendation

- nicht geeignet / not suitable

■ unbeschichtete HM-Sorten / uncoated grades

■ beschichtete HM-Sorten / coated grades

■ bestückt/Cermet / brazed/Cermet

Abmessungen in mm

Dimensions in mm

Ausführung R oder L angeben

State R or L version

Hinweis:

t_{max} 6 mm nur bei Werkstück-Ø ≤ 25 mm erreichbar.

Note:

t_{max} 6 mm can be reached only with workpiece Ø ≤ 25 mm.

P	•
M	•
K	•
N	•
S	•
H	-

HM-Sorten
Carbide grades



Abstechen

Parting Off



Wendeschneidplatte

Indexable insert

S274

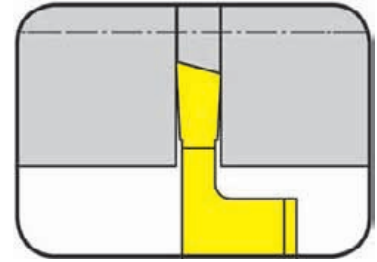

Stechtiefe bis Stechbreite	Depth of groove up to Width of groove	6 mm 0,8-2 mm
-------------------------------	--	------------------

präzisionsgeschliffen
precision ground

für Klemhalter
for Toolholder

Typ H274
Type KT274
KTC274
974
R76
H274KM
HC274KM

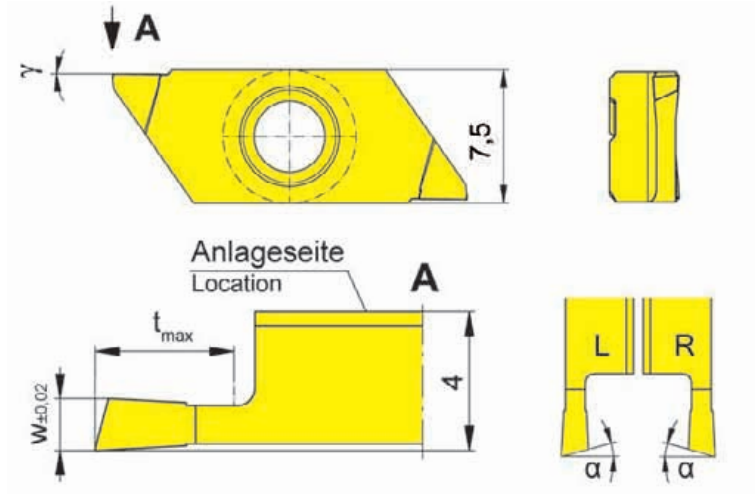

R = rechts wie gezeichnet
R = right hand version shown

L = links spiegelbildlich
L = left hand version

Wechselgenauigkeit
Länge ± 0,015 mm
Indexability length
± 0,015 mm

Bestellnummer Part number	w	t _{max}	α	γ	Größe Size	TH35
LS274.1508.03.M0R	0,8	3	15°	0°	04	▲
LS274.1510.03.M0R	1,0	3	15°	0°	04	▲
LS274.1515.04.M0R	1,5	4	15°	0°	04	▲
LS274.1520.06.M0R	2,0	6	15°	0°	04	▲
RS274.1508.03.M0L	0,8	3	15°	0°	04	▲
RS274.1510.03.M0L	1,0	3	15°	0°	04	▲
RS274.1515.04.M0L	1,5	4	15°	0°	04	▲
RS274.1520.06.M0L	2,0	6	15°	0°	04	▲

- ▲ ab Lager / on stock Δ 4 Wochen / 4 weeks x auf Anfrage / upon request
- empfohlen / recommended
- o bedingt einsetzbar / alternative recommendation
- nicht geeignet / not suitable
- unbeschichtete HM-Sorten / uncoated grades
- beschichtete HM-Sorten / coated grades
- bestückt/Cermet / brazed/Cermet

P	•
M	•
K	•
N	•
S	•
H	-

HM-Sorten
Carbide grades

Abmessungen in mm
Dimensions in mm

Ausführung R oder L angeben
State R or L version

Hinweis:

t_{max} 6 mm nur bei Werkstück-Ø ≤ 25 mm erreichbar.

Note:

t_{max} 6 mm can be reached only with workpiece Ø ≤ 25 mm.



Gewindedrehen (außen) Teilprofil

Threading (external) Partial profile



Wendeschneidplatte

Indexable insert

274

Metrisches ISO-Gewinde
Metric ISO thread

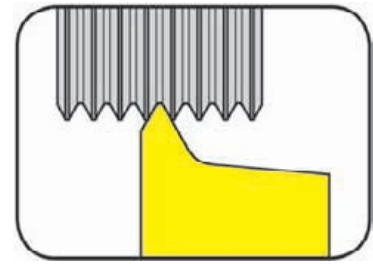

Steigung	Pitch	0,25-0,4 mm
----------	-------	-------------

präzisionsgeschliffen
precision ground

für Klemhalter
for Toolholder

- Typ H274
Type KT274
KTC274
974
R76
H274KM
HC274KM

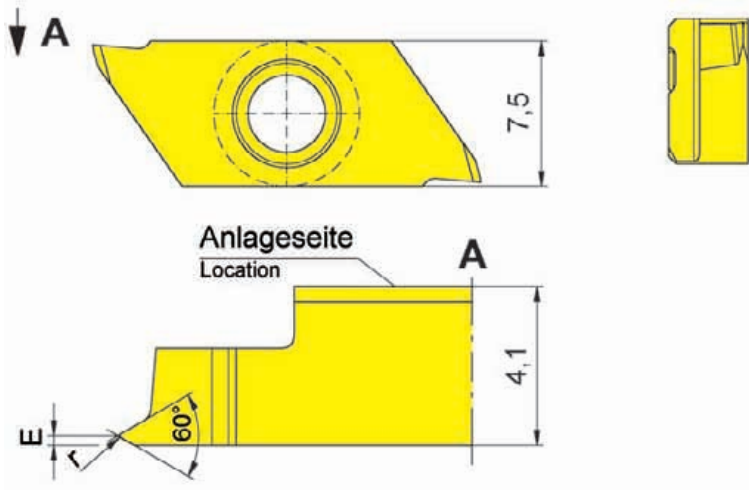

R = rechts wie gezeichnet
R = right hand version shown

Wechselgenauigkeit
Länge ± 0,015 mm
Indexability length
± 0,015 mm

Bestellnummer Part number	P	E	r	Größe Size	TH35
RS274.0102.01	0,25	0,20	0,04	04	▲
RS274.0203.01	0,35	0,25	0,05	04	▲
RS274.0204.01	0,40	0,30	0,06	04	▲

▲ ab Lager / on stock Δ 4 Wochen / 4 weeks x auf Anfrage / upon request

● empfohlen / recommended

o bedingt einsetzbar / alternative recommendation

- nicht geeignet / not suitable

■ unbeschichtete HM-Sorten / uncoated grades

■ beschichtete HM-Sorten / coated grades

■ bestückt/Cermet / brazed/Cermet

Abmessungen in mm

Dimensions in mm

HM-Sorten
Carbide grades

Keine Unterlegplatte erforderlich. Sämtliche HORN-Gewindeprofile sind mit einem **KEGELMANTEL-FREISCHLIFF** versehen.

No shims necessary. All HORN thread profiles are manufactured with **full ground radial clearance**.

P	•
M	•
K	•
N	•
S	•
H	-

Gewindedrehen (außen) Vollprofil

Threading (external) Full profile



Wendeschneidplatte

Indexable insert

274

Metrisches ISO-Gewinde
Metric ISO thread

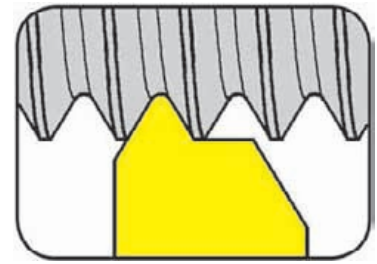

Steigung	Pitch	0,5-1,5 mm
----------	-------	------------

präzisionsgeschliffen
precision ground

für Klemmhalter
for Toolholder

Typ H274
Type KT274
KTC274
974
R76
H274KM
HC274KM

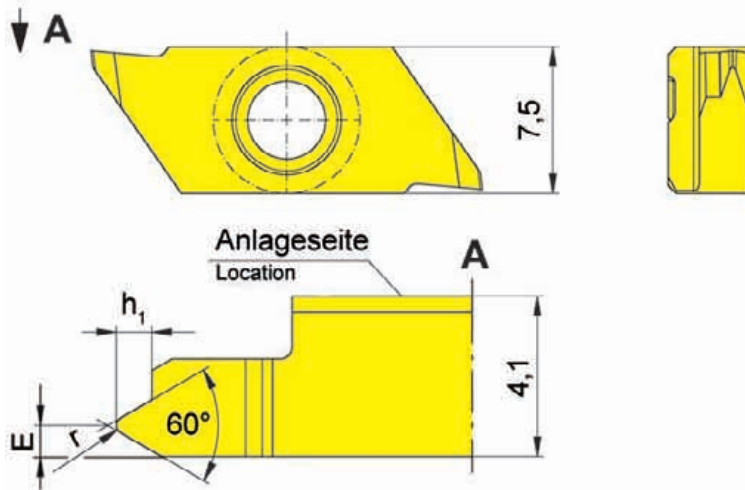

R = rechts wie gezeichnet
R = right hand version shown

L = links spiegelbildlich
L = left hand version

Wechselgenauigkeit
Länge ± 0,015 mm
Indexability length
± 0,015 mm

Bestellnummer Part number	P	E	r	h ₁	Größe Size	TH35
R/LS274.0305.02	0,50	0,40	0,07	0,31	04	▲/△
R/LS274.0306.02	0,60	0,45	0,09	0,37	04	▲/△
R/LS274.0307.02	0,70	0,50	0,10	0,43	04	▲/△
R/LS274.0407.02	0,75	0,50	0,11	0,46	04	▲/▲
R/LS274.0408.02	0,80	0,55	0,12	0,49	04	▲/△
R/LS274.0610.02	1,00	0,60	0,14	0,61	04	▲/▲
R/LS274.0712.02	1,25	0,70	0,15	0,77	04	▲/▲
R/LS274.0915.02	1,50	0,80	0,20	0,92	04	▲/△

▲ ab Lager / on stock Δ 4 Wochen / 4 weeks x auf Anfrage / upon request

● empfohlen / recommended

o bedingt einsetzbar / alternative recommendation

- nicht geeignet / not suitable

■ unbeschichtete HM-Sorten / uncoated grades

■ beschichtete HM-Sorten / coated grades

■ bestückt/Cermet / brazed/Cermet

P	•
M	•
K	•
N	•
S	•
H	-

Abmessungen in mm

Dimensions in mm

Ausführung R oder L angeben

State R or L version

Keine Unterlegplatte erforderlich. Sämtliche HORN-Gewindeprofile sind mit einem **KEGELMANTEL-FREISCHLIFF** versehen.

No shims necessary. All HORN thread profiles are manufactured with **full ground radial clearance**.

HM-Sorten
Carbide grades



Gewindedrehen (außen) Vollprofil

Threading (external) Full profile



Wendeschneidplatte

Indexable insert

274

Metrisches ISO-Gewinde
Metric ISO thread

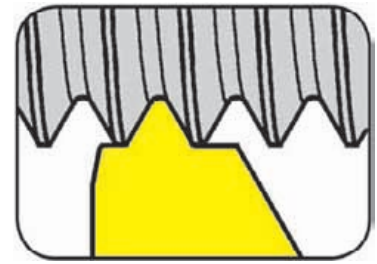

Steigung	Pitch	0,5-1,5 mm
----------	-------	------------

präzisionsgeschliffen
precision ground

für Klemmhalter
for Toolholder

Typ H274
Type KT274
KTC274
974
R76
H274KM
HC274KM

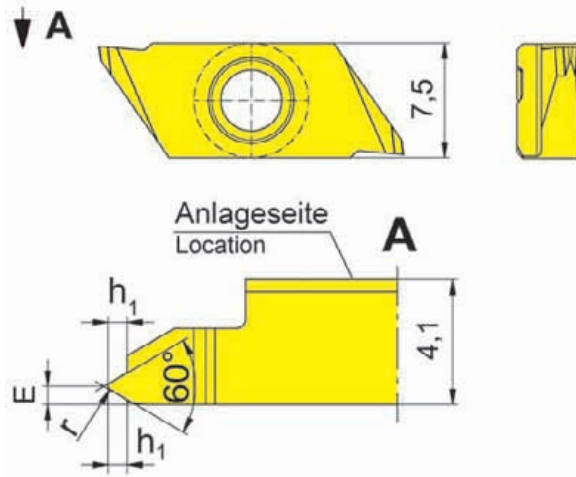

R = rechts wie gezeichnet
R = right hand version shown

L = links spiegelbildlich
L = left hand version

Wechselgenauigkeit
Länge ± 0,015 mm
Indexability length
± 0,015 mm

Bestellnummer Part number	P	E	r	h ₁	Größe Size	TH35
R/LS274.0305.03	0,50	0,40	0,07	0,31	04	▲▲
R/LS274.0306.03	0,60	0,45	0,09	0,37	04	▲▲
R/LS274.0307.03	0,70	0,50	0,10	0,43	04	▲▲
R/LS274.0407.03	0,75	0,50	0,11	0,46	04	▲▲
R/LS274.0408.03	0,80	0,55	0,12	0,49	04	▲▲
R/LS274.0610.03	1,00	0,60	0,14	0,61	04	▲▲
R/LS274.0712.03	1,25	0,70	0,15	0,77	04	▲▲
R/LS274.0915.03	1,50	0,80	0,20	0,92	04	▲▲

- ▲ ab Lager / on stock Δ 4 Wochen / 4 weeks x auf Anfrage / upon request
- empfohlen / recommended
- o bedingt einsetzbar / alternative recommendation
- nicht geeignet / not suitable
- unbeschichtete HM-Sorten / uncoated grades
- beschichtete HM-Sorten / coated grades
- bestückt/Cermet / brazed/Cermet

P	•
M	•
K	•
N	•
S	•
H	-

Abmessungen in mm
Dimensions in mm

HM-Sorten
Carbide grades

Ausführung R oder L angeben
State R or L version

Keine Unterlegplatte erforderlich. Sämtliche HORN-Gewindeprofile sind mit einem **KEGELMANTEL-FREISCHLIFF** versehen.
No shims necessary. All HORN thread profiles are manufactured with **full ground radial clearance**.



Einstechen und Drehen

Grooving and Turning



Klemmhalter

Toolholder

H274...E

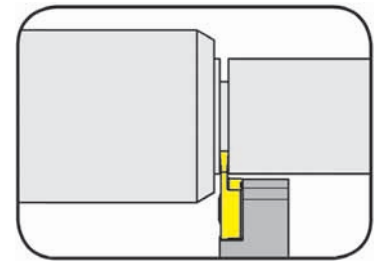

Stechtiefe	Depth of groove	6 mm
Stechbreite	Width of groove	0,5-3,0 mm

für Wendeschneidplatte
for Indexable insert

Typ S274...E
Type

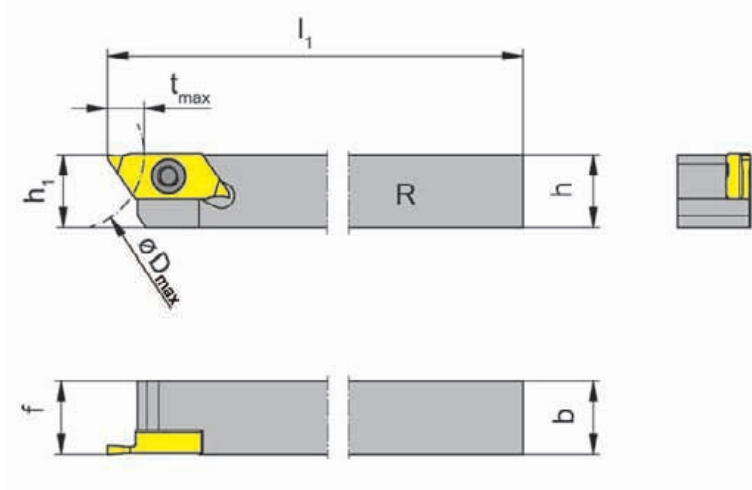

R = rechts wie gezeichnet
R = right hand version shown

L = links spiegelbildlich
L = left hand version

Bestellnummer Part number	h	b	l ₁	h ₁	t _{max}	D _{max}	f	Größe Size
R/LH274.1010.04.E	10	10	100	10	6	25	10	04
R/LH274.1212.04.E	12	12	100	12	6	25	12	04
R/LH274.1616.04.E	16	16	125	16	6	25	16	04
R/LH274.2020.04.E	20	20	125	20	6	25	20	04

Ausführung R oder L angeben
State R or L version

Abmessungen in mm
Dimensions in mm

Weitere Abmessungen auf Anfrage
Further sizes upon request

Das Anzugsdrehmoment der Schrauben finden Sie in den Technischen Hinweisen.
For torque specification of the screw, please see Technical Instructions.

Ersatzteile

Spare Parts

Klemmhalter Toolholder	Schraube Screw	TORX PLUS®-Schlüssel TORX PLUS® Wrench
R/LH274...	030.3509.T15P	T15PQ



Einstecken und Längsdrehen

Grooving and Side Turning



Wendeschneidplatte

Indexable insert

S274...E

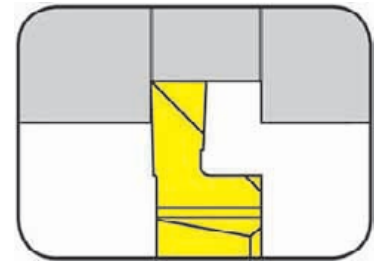

Stechtiefe bis Stechbreite	Depth of groove up to Width of groove	4,5 mm 1,5-3 mm
-------------------------------	--	--------------------

präzisionsgeschliffen
precision ground

für Klemhalter
for Toolholder

Typ H274...E
Type

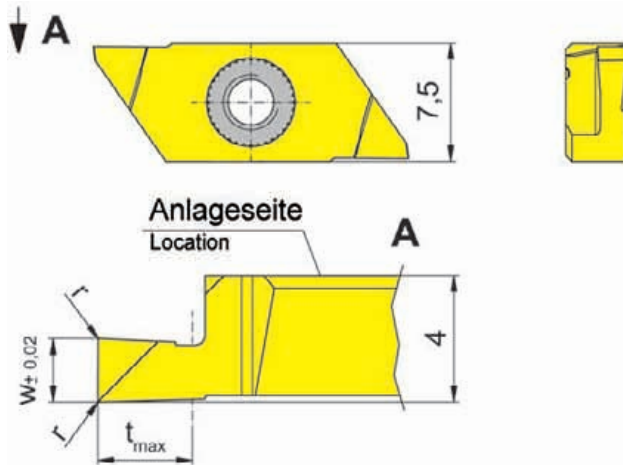

R = rechts wie gezeichnet
R = right hand version shown

L = links spiegelbildlich
L = left hand version

Wechselgenauigkeit
Länge ± 0,015 mm
Indexability length
± 0,015 mm

Bestellnummer Part number	w	r	t _{max}	Größe Size	TH35
R/LS274.0150.P0.E	1,5	0,05	2,25	04	ΔΔ
R/LS274.0200.P0.E	2,0	0,05	3,00	04	ΔΔ
R/LS274.0250.P0.E	2,5	0,10	3,75	04	ΔΔ
R/LS274.0300.P0.E	3,0	0,10	4,50	04	ΔΔ

▲ ab Lager / on stock Δ 4 Wochen / 4 weeks x auf Anfrage / upon request

● empfohlen / recommended

o bedingt einsetzbar / alternative recommendation

- nicht geeignet / not suitable

■ unbeschichtete HM-Sorten / uncoated grades

■ beschichtete HM-Sorten / coated grades

■ bestückt/Cermet / brazed/Cermet

Abmessungen in mm

Dimensions in mm

Ausführung R oder L angeben

State R or L version

P	•
M	•
K	•
N	•
S	•
H	-

HM-Sorten
Carbide grades

Einstechen und Längsdrehen

Grooving and Side Turning



Wendeschneidplatte

Indexable insert

S274...E

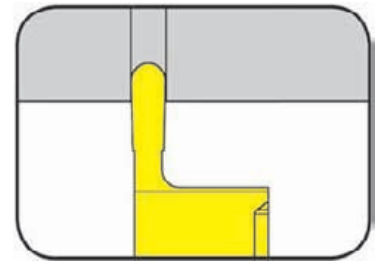

Stechtiefe bis Vollradius	Depth of groove up to Full radius	4 mm 0,25-1 mm
---------------------------	-----------------------------------	-------------------

präzisionsgeschliffen
precision ground

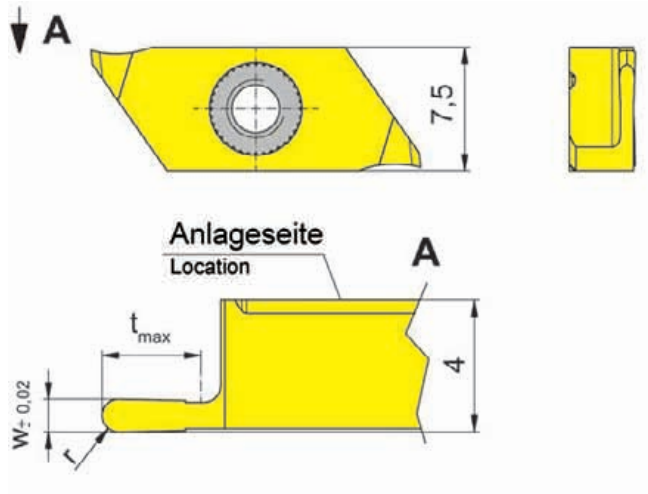

für Klemhalter
for Toolholder

Typ H274...E
Type

R = rechts wie gezeichnet
R = right hand version shown

L = links spiegelbildlich
L = left hand version

Wechselgenauigkeit
Länge $\pm 0,015$ mm
Indexability length
 $\pm 0,015$ mm

Bestellnummer Part number	w	t _{max}	r	Größe Size	TH35
R/LS274.0205.01.10.E	0,5	1,5	0,25	04	ΔΔ
R/LS274.0510.03.10.E	1,0	3,0	0,50	04	ΔΔ
R/LS274.1020.04.10.E	2,0	4,0	1,00	04	ΔΔ

▲ ab Lager / on stock Δ 4 Wochen / 4 weeks x auf Anfrage / upon request

● empfohlen / recommended

o bedingt einsetzbar / alternative recommendation

- nicht geeignet / not suitable

■ unbeschichtete HM-Sorten / uncoated grades

■ beschichtete HM-Sorten / coated grades

■ bestückt/Cermet / brazed/Cermet

Abmessungen in mm

Dimensions in mm

Ausführung R oder L angeben

State R or L version

P	•
M	•
K	•
N	•
S	•
H	-

HM-Sorten
Carbide grades



Einstechen und Abstechen

Grooving and Parting Off



Wendeschneidplatte

Indexable insert

S274...E

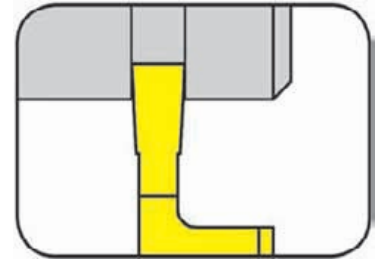

Stechtiefe bis Stechbreite	Depth of groove up to Width of groove	6 mm 0,5-2 mm
-------------------------------	--	------------------

präzisionsgeschliffen
precision ground

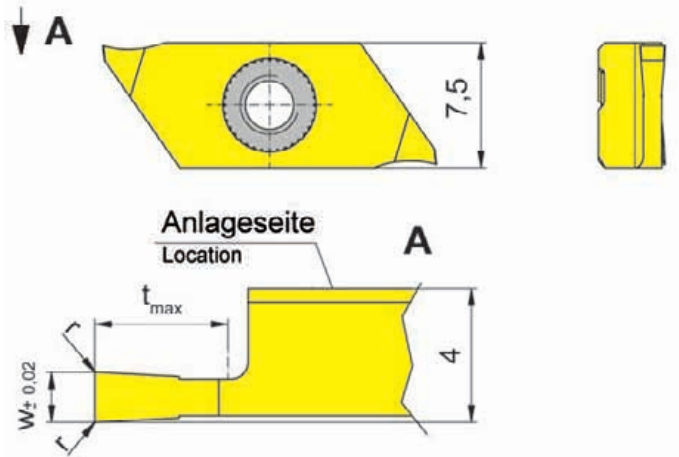

für Klemhalter
for Toolholder

Typ H274...E
Type

R = rechts wie gezeichnet
R = right hand version shown

L = links spiegelbildlich
L = left hand version

Wechselgenauigkeit
Länge ± 0,015 mm
Indexability length
± 0,015 mm

Bestellnummer Part number	w	r	t _{max}	Größe Size	TH35
R/LS274.0120.03.10.E	1,2	0,05	3,0	04	ΔΔ
R/LS274.0050.01.10.E	0,5	0,05	1,5	04	ΔΔ
R/LS274.0070.02.10.E	0,7	0,05	2,0	04	ΔΔ
R/LS274.0080.03.10.E	0,8	0,05	3,0	04	ΔΔ
R/LS274.0100.03.10.E	1,0	0,05	3,0	04	ΔΔ
R/LS274.0150.04.10.E	1,5	0,05	4,0	04	ΔΔ
R/LS274.0150.06.10.E	1,5	0,05	6,0	04	ΔΔ
R/LS274.0200.04.10.E	2,0	0,05	4,0	04	ΔΔ
R/LS274.0200.06.10.E	2,0	0,05	6,0	04	ΔΔ

▲ ab Lager / on stock Δ 4 Wochen / 4 weeks x auf Anfrage / upon request

● empfohlen / recommended

o bedingt einsetzbar / alternative recommendation

- nicht geeignet / not suitable

■ unbeschichtete HM-Sorten / uncoated grades

■ beschichtete HM-Sorten / coated grades

■ bestückt/Cermet / brazed/Cermet

Abmessungen in mm

Dimensions in mm

Ausführung R oder L angeben

State R or L version

P	•
M	•
K	•
N	•
S	•
H	-

HM-Sorten
Carbide grades



Einstechen und Abstechen

Grooving and Parting Off



Wendeschneidplatte

Indexable insert

S274...E

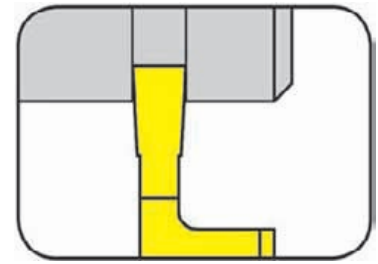

Stechtiefe bis Stechbreite	Depth of groove up to Width of groove	6 mm 0,5-2 mm
-------------------------------	--	------------------

präzisionsgeschliffen
precision ground

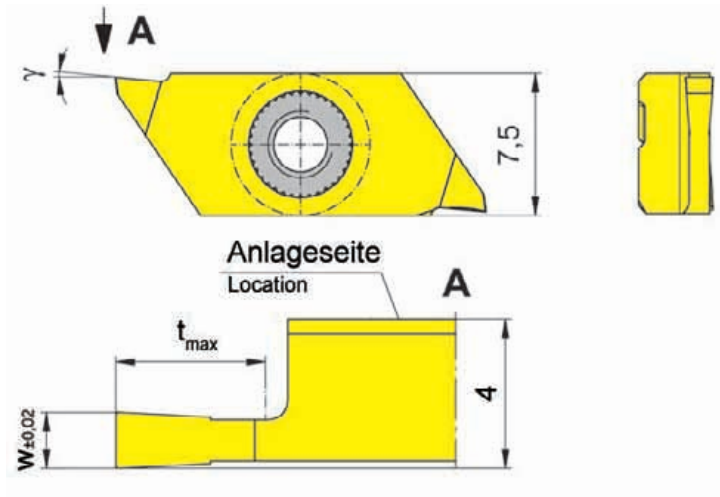

für Klemhalter
for Toolholder

Typ H274...E
Type

Wechselgenauigkeit
Länge ± 0,015 mm
Indexability length
± 0,015 mm

R = rechts wie gezeichnet
R = right hand version shown

L = links spiegelbildlich
L = left hand version

Bestellnummer Part number	w	t _{max}	γ	Größe Size	TH35
R/LS274.0050.01.20.E	0,5	1,5	5°	04	ΔΔ
R/LS274.0070.02.20.E	0,7	2,0	5°	04	ΔΔ
R/LS274.0080.03.20.E	0,8	3,0	5°	04	ΔΔ
R/LS274.0100.03.20.E	1,0	3,0	5°	04	ΔΔ
R/LS274.0120.03.20.E	1,2	3,0	5°	04	ΔΔ
R/LS274.0150.04.20.E	1,5	4,0	5°	04	ΔΔ
R/LS274.0150.06.20.E	1,5	6,0	5°	04	ΔΔ
R/LS274.0200.04.20.E	2,0	4,0	5°	04	ΔΔ
R/LS274.0200.06.20.E	2,0	6,0	5°	04	ΔΔ

▲ ab Lager / on stock Δ 4 Wochen / 4 weeks x auf Anfrage / upon request

● empfohlen / recommended

o bedingt einsetzbar / alternative recommendation

- nicht geeignet / not suitable

■ unbeschichtete HM-Sorten / uncoated grades

■ beschichtete HM-Sorten / coated grades

■ bestückt/Cermet / brazed/Cermet

Abmessungen in mm

Dimensions in mm

Ausführung R oder L angeben

State R or L version

P	•
M	•
K	•
N	•
S	•
H	-

HM-Sorten
Carbide grades



Einstechen und Abstechen

Grooving and Parting Off



Wendeschneidplatte

Indexable insert

S274...E

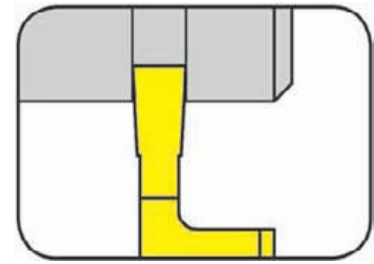

Stechtiefe bis Stechbreite	Depth of groove up to Width of groove	6 mm 0,5-2 mm
-------------------------------	--	------------------

präzisionsgeschliffen
precision ground

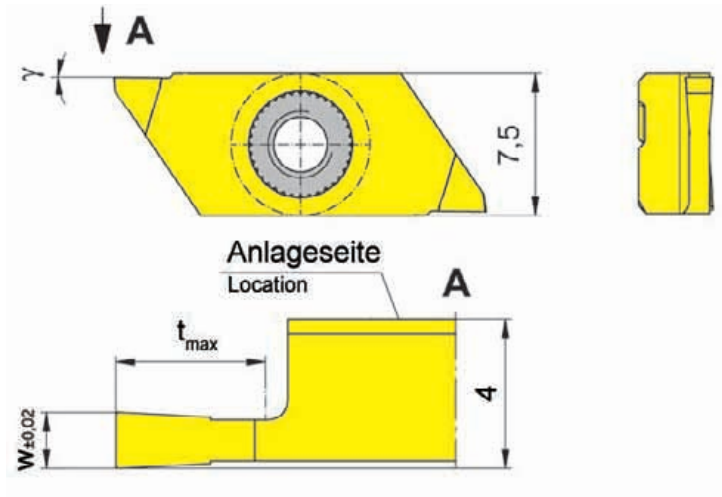

für Klemhalter
for Toolholder

Typ H274...E
Type

Wechselgenauigkeit
Länge $\pm 0,015$ mm
Indexability length
 $\pm 0,015$ mm

R = rechts wie gezeichnet
R = right hand version shown

L = links spiegelbildlich
L = left hand version

Bestellnummer Part number	w	t _{max}	γ	Größe Size	TH35
R/LS274.0050.01.M0.E	0,5	1,5	0°	04	ΔΔ
R/LS274.0070.02.M0.E	0,7	2,0	0°	04	ΔΔ
R/LS274.0080.03.M0.E	0,8	3,0	0°	04	ΔΔ
R/LS274.0100.03.M0.E	1,0	3,0	0°	04	ΔΔ
R/LS274.0120.03.M0.E	1,2	3,0	0°	04	ΔΔ
R/LS274.0150.04.M0.E	1,5	4,0	0°	04	ΔΔ
R/LS274.0150.06.M0.E	1,5	6,0	0°	04	ΔΔ
R/LS274.0200.04.M0.E	2,0	4,0	0°	04	ΔΔ
R/LS274.0200.06.M0.E	2,0	6,0	0°	04	ΔΔ

▲ ab Lager / on stock Δ 4 Wochen / 4 weeks x auf Anfrage / upon request

● empfohlen / recommended

o bedingt einsetzbar / alternative recommendation

- nicht geeignet / not suitable

■ unbeschichtete HM-Sorten / uncoated grades

■ beschichtete HM-Sorten / coated grades

■ bestückt/Cermet / brazed/Cermet

Abmessungen in mm

Dimensions in mm

Ausführung R oder L angeben

State R or L version

P	•
M	•
K	•
N	•
S	•
H	-

HM-Sorten
Carbide grades

L

Rückwärtsdrehen (außen)

Backturning (external)



Wendeschneidplatte

Indexable insert

S274...E

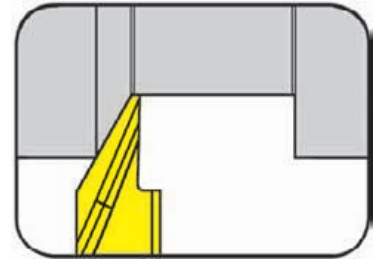

Schnitttiefe bis	Depth of cut up to	6 mm
------------------	--------------------	------

präzisionsgeschliffen
precision ground

für Klemhalter
for Toolholder

Typ H274...E
Type

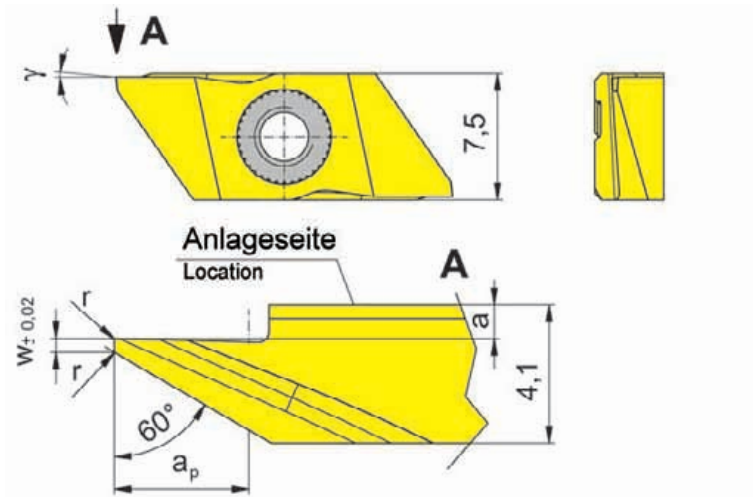

R = rechts wie gezeichnet
R = right hand version shown

L = links spiegelbildlich
L = left hand version

Wechselgenauigkeit
Länge ± 0,015 mm
Indexability length
± 0,015 mm

Bestellnummer Part number	w	r	a	γ	a _p	Größe Size	K10	TH35
R/LS274.0060.04.10.E	-	0,05	1,00	15°	4	04		ΔΔ
R/LS274.0460.04.10.E	0,4	0,05	1,00	15°	4	04		ΔΔ
R/LS274.0460.04.M0.E	0,4	0,05	1,00	0°	4	04	ΔΔ	ΔΔ
R/LS274.0560.06.11.E	0,5	0,10	0,05	15°	6	04		ΔΔ

▲ ab Lager / on stock Δ 4 Wochen / 4 weeks x auf Anfrage / upon request

● empfohlen / recommended

o bedingt einsetzbar / alternative recommendation

- nicht geeignet / not suitable

■ unbeschichtete HM-Sorten / uncoated grades

■ beschichtete HM-Sorten / coated grades

■ bestückt/Cermet / brazed/Cermet

Abmessungen in mm

Dimensions in mm

Ausführung R oder L angeben

State R or L version

P	●	●
M	○	●
K	●	●
N	●	●
S	○	●
H	-	-

HM-Sorten
Carbide grades



Längsdrehen

Side Turning



Wendeschneidplatte

Indexable insert

S274...E

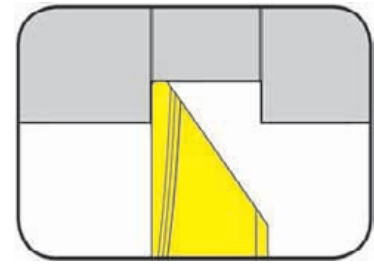

Schnitttiefe bis	Depth of cut up to	6 mm
------------------	--------------------	------

präzisionsgeschliffen
precision ground

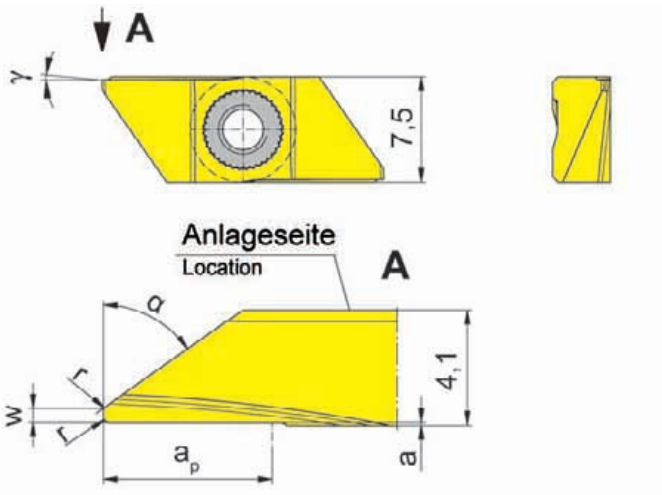

für Klemhalter
for Toolholder

Typ H274...E
Type

R = rechts wie gezeichnet
R = right hand version shown

L = links spiegelbildlich
L = left hand version

Wechselgenauigkeit
Länge ± 0,015 mm
Indexability length
± 0,015 mm

Bestellnummer Part number	w	r	a	γ	a _p	α	Größe Size	TH35
R/LS274.0035.04.20.E	-	0,05	0,1	5°	4	35°	04	ΔΔ
R/LS274.0235.04.20.E	0,2	-	0,1	5°	4	35°	04	ΔΔ
R/LS274.0535.06.20.E	0,5	0,20	0,1	5°	6	35°	04	ΔΔ
R/LS274.0055.04.20.E	-	0,05	0,1	5°	4	55°	04	ΔΔ
R/LS274.0255.04.20.E	0,2	-	0,1	5°	4	55°	04	ΔΔ
R/LS274.0555.06.20.E	0,5	0,20	0,1	5°	6	55°	04	ΔΔ

▲ ab Lager / on stock Δ 4 Wochen / 4 weeks x auf Anfrage / upon request

● empfohlen / recommended

o bedingt einsetzbar / alternative recommendation

- nicht geeignet / not suitable

□ unbeschichtete HM-Sorten / uncoated grades

■ beschichtete HM-Sorten / coated grades

■ bestückt/Cermet / brazed/Cermet

Abmessungen in mm

Dimensions in mm

Ausführung R oder L angeben

State R or L version

P	•
M	•
K	•
N	•
S	•
H	-

HM-Sorten
Carbide grades

L

Abstechen

Parting Off



Wendeschneidplatte

Indexable insert

S274...E



Stechtiefe bis Stechbreite	Depth of groove up to Width of groove	6 mm 0,8-2 mm
-------------------------------	--	------------------

präzisionsgeschliffen
precision ground

für Klemhalter
for Toolholder

Typ H274...E
Type

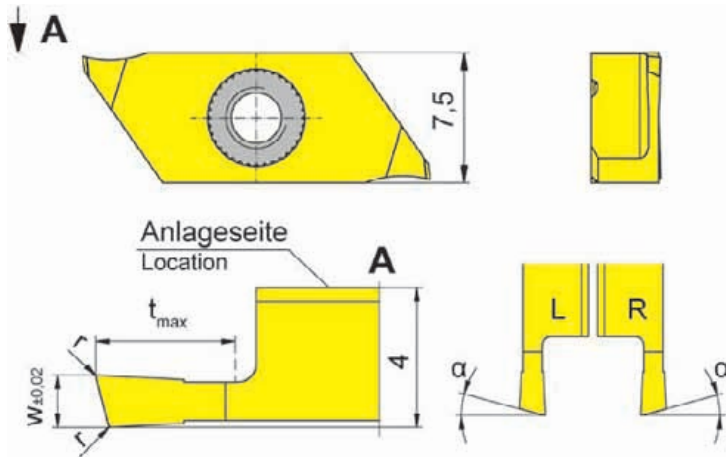

R = rechts wie gezeichnet
R = right hand version shown

L = links spiegelbildlich
L = left hand version

Wechselgenauigkeit
Länge ± 0,015 mm
Indexability length
± 0,015 mm

Bestellnummer Part number	w	r	t _{max}	α	Größe Size	TH35
R/LS274.1508.03.10.E	0,8	0,05	3	15°	04	ΔΔ
R/LS274.1510.03.10.E	1,0	0,05	3	15°	04	ΔΔ
R/LS274.1515.04.10.E	1,5	0,05	4	15°	04	ΔΔ
R/LS274.1520.06.10.E	2,0	0,05	6	15°	04	ΔΔ

▲ ab Lager / on stock Δ 4 Wochen / 4 weeks x auf Anfrage / upon request

● empfohlen / recommended

o bedingt einsetzbar / alternative recommendation

- nicht geeignet / not suitable

■ unbeschichtete HM-Sorten / uncoated grades

■ beschichtete HM-Sorten / coated grades

■ bestückt/Cermet / brazed/Cermet

Abmessungen in mm

Dimensions in mm

Ausführung R oder L angeben

State R or L version

Hinweis:

t_{max} 6 mm nur bei Werkstück-Ø ≤ 25 mm erreichbar.

Note:

t_{max} 6 mm can be reached only with workpiece Ø ≤ 25 mm.

P	•
M	•
K	•
N	•
S	•
H	-

HM-Sorten
Carbide grades



Abstechen

Parting Off



Wendeschneidplatte

Indexable insert

S274...E

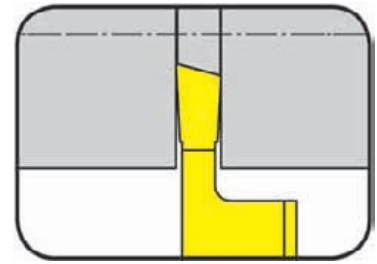

Stechtiefe bis Stechbreite	Depth of groove up to Width of groove	6 mm 0,8-2 mm
-------------------------------	--	------------------

präzisionsgeschliffen
precision ground

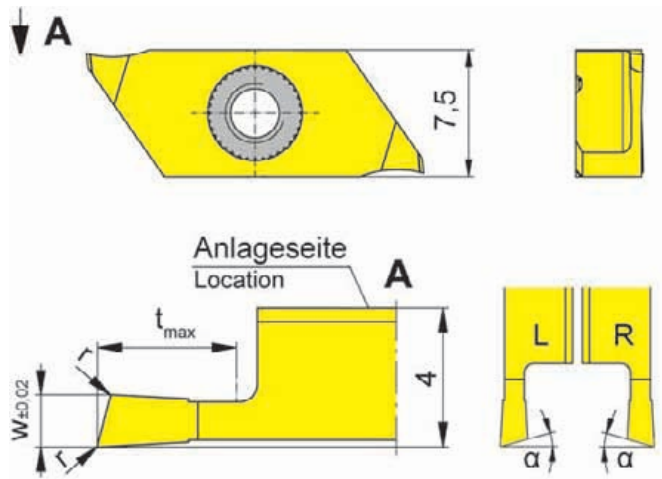

für Klemhalter
for Toolholder

Typ H274...E
Type

R = rechts wie gezeichnet
R = right hand version shown

L = links spiegelbildlich
L = left hand version

Wechselgenauigkeit
Länge ± 0,015 mm
Indexability length
± 0,015 mm

Bestellnummer Part number	w	r	t _{max}	α	Größe Size	TH35
LS274.1508.03.1R.E	0,8	0,05	3	15°	04	Δ
LS274.1510.03.1R.E	1,0	0,05	3	15°	04	Δ
LS274.1515.04.1R.E	1,5	0,05	4	15°	04	Δ
LS274.1520.06.1R.E	2,0	0,05	6	15°	04	Δ
RS274.1508.03.1L.E	0,8	0,05	3	15°	04	Δ
RS274.1510.03.1L.E	1,0	0,05	3	15°	04	Δ
RS274.1515.04.1L.E	1,5	0,05	4	15°	04	Δ
RS274.1520.06.1L.E	2,0	0,05	6	15°	04	Δ

▲ ab Lager / on stock Δ 4 Wochen / 4 weeks x auf Anfrage / upon request

● empfohlen / recommended

o bedingt einsetzbar / alternative recommendation

- nicht geeignet / not suitable

■ unbeschichtete HM-Sorten / uncoated grades

■ beschichtete HM-Sorten / coated grades

■ bestückt/Cermet / brazed/Cermet

Abmessungen in mm

Dimensions in mm

Ausführung R oder L angeben

State R or L version

Hinweis:

t_{max} 6 mm nur bei Werkstück-Ø ≤ 25 mm erreichbar.

Note:

t_{max} 6 mm can be reached only with workpiece Ø ≤ 25 mm.

P	•
M	•
K	•
N	•
S	•
H	-

HM-Sorten
Carbide grades

L

Abstechen

Parting Off



Wendeschneidplatte

Indexable insert

S274...E

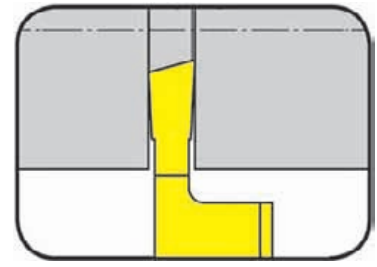

Stechtiefe bis Stechbreite	Depth of groove up to Width of groove	6 mm 1,5-2 mm
-------------------------------	--	------------------

präzisionsgeschliffen
precision ground

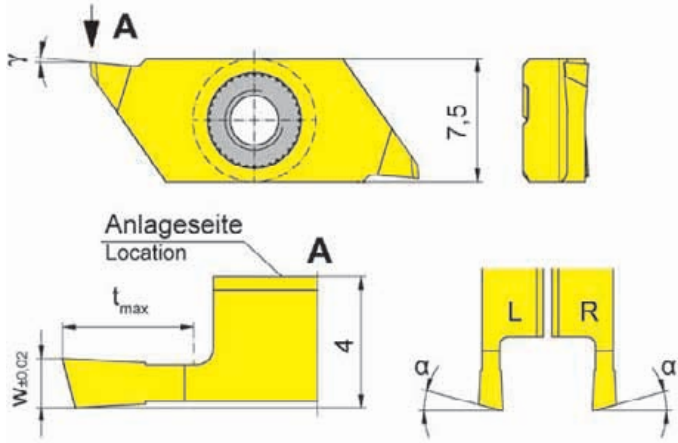

für Klemhalter
for Toolholder

Typ H274...E
Type

Wechselgenauigkeit
Länge ± 0,015 mm
Indexability length
± 0,015 mm

R = rechts wie gezeichnet
R = right hand version shown

L = links spiegelbildlich
L = left hand version

Bestellnummer Part number	w	t _{max}	α	γ	Größe Size	TH35
R/LS274.1515.04.20.E	1,5	4	15°	5°	04	ΔΔ
R/LS274.1520.06.20.E	2,0	6	15°	5°	04	ΔΔ

- ▲ ab Lager / on stock Δ 4 Wochen / 4 weeks x auf Anfrage / upon request
- empfohlen / recommended
- o bedingt einsetzbar / alternative recommendation
- nicht geeignet / not suitable
- unbeschichtete HM-Sorten / uncoated grades
- beschichtete HM-Sorten / coated grades
- bestückt/Cermet / brazed/Cermet

Abmessungen in mm
Dimensions in mm

Ausführung R oder L angeben
State R or L version

Hinweis:

t_{max} 6 mm nur bei Werkstück-Ø ≤ 25 mm erreichbar.

Note:

t_{max} 6 mm can be reached only with workpiece Ø ≤ 25 mm.

P	•
M	•
K	•
N	•
S	•
H	-

HM-Sorten
Carbide grades



Abstechen

Parting Off



Wendeschneidplatte

Indexable insert

S274...E

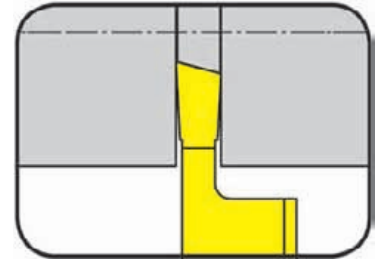

Stechtiefe bis Stechbreite	Depth of groove up to Width of groove	6 mm 1,5-2 mm
-------------------------------	--	------------------

präzisionsgeschliffen
precision ground

für Klemmhalter
for Toolholder

Typ H274...E
Type

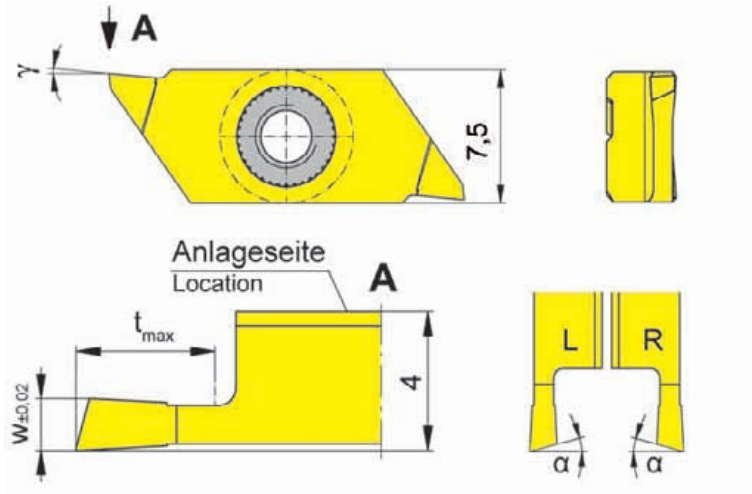

R = rechts wie gezeichnet
R = right hand version shown

L = links spiegelbildlich
L = left hand version

Wechselgenauigkeit
Länge $\pm 0,015$ mm
Indexability length
 $\pm 0,015$ mm

Bestellnummer Part number	w	t _{max}	α	γ	Größe Size	TH35
LS274.1515.04.2R.E	1,5	4	15°	5°	04	Δ
LS274.1520.06.2R.E	2,0	6	15°	5°	04	Δ
RS274.1515.04.2L.E	1,5	4	15°	5°	04	Δ
RS274.1520.06.2L.E	2,0	6	15°	5°	04	Δ

▲ ab Lager / on stock Δ 4 Wochen / 4 weeks x auf Anfrage / upon request

● empfohlen / recommended

o bedingt einsetzbar / alternative recommendation

- nicht geeignet / not suitable

■ unbeschichtete HM-Sorten / uncoated grades

■ beschichtete HM-Sorten / coated grades

■ bestückt/Cermet / brazed/Cermet

Abmessungen in mm

Dimensions in mm

Ausführung R oder L angeben

State R or L version

Hinweis:

t_{max} 6 mm nur bei Werkstück-Ø ≤ 25 mm erreichbar.

Note:

t_{max} 6 mm can be reached only with workpiece Ø ≤ 25 mm.

P	•
M	•
K	•
N	•
S	•
H	-

HM-Sorten
Carbide grades



Abstechen

Parting Off



Wendeschneidplatte

Indexable insert

S274...E

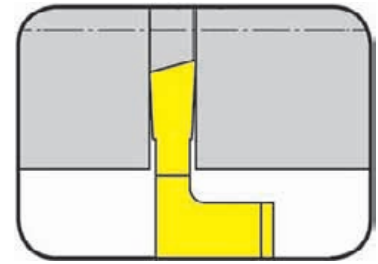

Stechtiefe bis Stechbreite	Depth of groove up to Width of groove	6 mm 0,8-2 mm
-------------------------------	--	------------------

präzisionsgeschliffen
precision ground

für Klemhalter
for Toolholder

Typ H274...E
Type

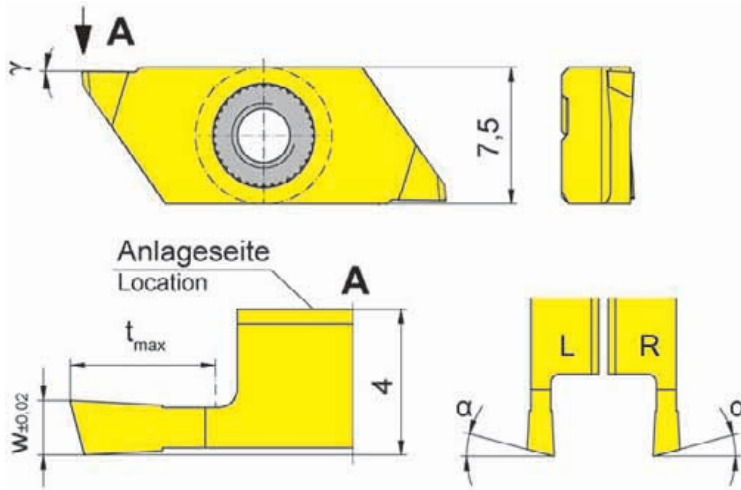

R = rechts wie gezeichnet
R = right hand version shown

L = links spiegelbildlich
L = left hand version

Wechselgenauigkeit
Länge ± 0,015 mm
Indexability length
± 0,015 mm

Bestellnummer Part number	w	t _{max}	α	γ	Größe Size	TH35
R/LS274.1508.03.M0.E	0,8	3	15°	0°	04	ΔΔ
R/LS274.1510.03.M0.E	1,0	3	15°	0°	04	ΔΔ
R/LS274.1515.04.M0.E	1,5	4	15°	0°	04	ΔΔ
R/LS274.1520.06.M0.E	2,0	6	15°	0°	04	ΔΔ

▲ ab Lager / on stock Δ 4 Wochen / 4 weeks x auf Anfrage / upon request

● empfohlen / recommended

o bedingt einsetzbar / alternative recommendation

- nicht geeignet / not suitable

■ unbeschichtete HM-Sorten / uncoated grades

■ beschichtete HM-Sorten / coated grades

■ bestückt/Cermet / brazed/Cermet

Abmessungen in mm

Dimensions in mm

Ausführung R oder L angeben

State R or L version

Hinweis:

t_{max} 6 mm nur bei Werkstück-Ø ≤ 25 mm erreichbar.

Note:

t_{max} 6 mm can be reached only with workpiece Ø ≤ 25 mm.

P	•
M	•
K	•
N	•
S	•
H	-

HM-Sorten
Carbide grades



Abstechen

Parting Off



Wendeschneidplatte

Indexable insert

S274...E

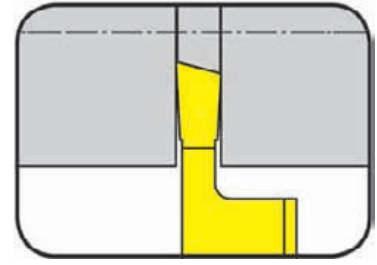

Stechtiefe bis Stechbreite	Depth of groove up to Width of groove	6 mm 0,8-2 mm
-------------------------------	--	------------------

präzisionsgeschliffen
precision ground

für Klemhalter
for Toolholder

Typ H274...E
Type

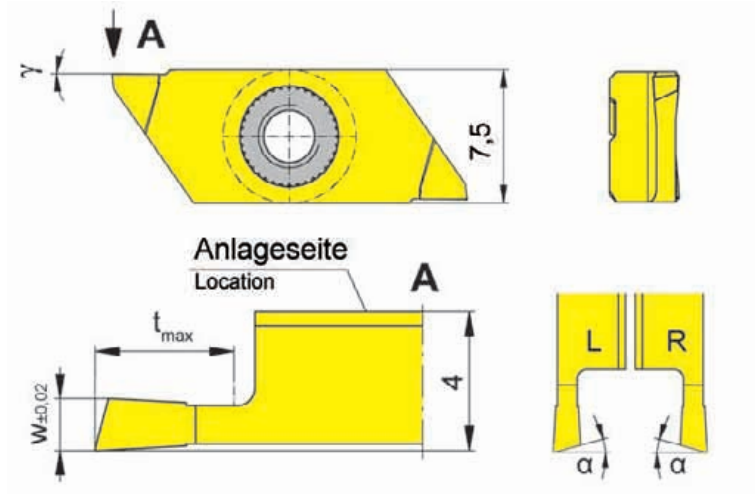

R = rechts wie gezeichnet
R = right hand version shown

L = links spiegelbildlich
L = left hand version

Wechselgenauigkeit
Länge ± 0,015 mm
Indexability length
± 0,015 mm

Bestellnummer Part number	w	t _{max}	α	γ	Größe Size	TH35
LS274.1508.03.MR.E	0,8	3	15°	0°	04	Δ
LS274.1510.03.MR.E	1,0	3	15°	0°	04	Δ
LS274.1515.04.MR.E	1,5	4	15°	0°	04	Δ
LS274.1520.06.MR.E	2,0	6	15°	0°	04	Δ
RS274.1508.03.ML.E	0,8	3	15°	0°	04	Δ
RS274.1510.03.ML.E	1,0	3	15°	0°	04	Δ
RS274.1515.04.ML.E	1,5	4	15°	0°	04	Δ
RS274.1520.06.ML.E	2,0	6	15°	0°	04	Δ

- ▲ ab Lager / on stock Δ 4 Wochen / 4 weeks x auf Anfrage / upon request
- empfohlen / recommended
- o bedingt einsetzbar / alternative recommendation
- nicht geeignet / not suitable
- unbeschichtete HM-Sorten / uncoated grades
- beschichtete HM-Sorten / coated grades
- bestückt/Cermet / brazed/Cermet

P	•
M	•
K	•
N	•
S	•
H	-

HM-Sorten
Carbide grades

Abmessungen in mm
Dimensions in mm

Ausführung R oder L angeben
State R or L version

Hinweis:

t_{max} 6 mm nur bei Werkstück-Ø ≤ 25 mm erreichbar.

Note:

t_{max} 6 mm can be reached only with workpiece Ø ≤ 25 mm.



Gewindedrehen (außen) Teilprofil

Threading (external) Partial profile



Wendeschneidplatte

Indexable insert

S274...E

Metrisches ISO-Gewinde
Metric ISO thread

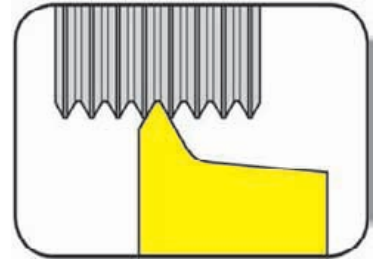

Steigung	Pitch	0,25-0,4 mm
----------	-------	-------------

präzisionsgeschliffen
precision ground

für Klemhalter
for Toolholder

Typ H274...E
Type

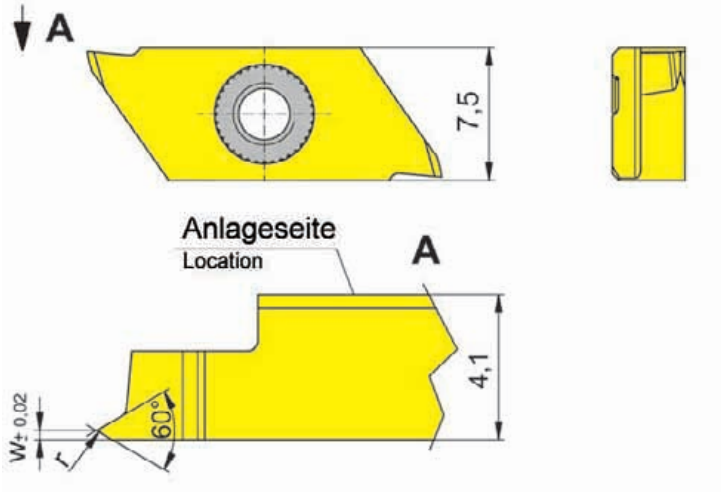

R = rechts wie gezeichnet
R = right hand version shown

Wechselgenauigkeit
Länge ± 0,015 mm
Indexability length
± 0,015 mm

Bestellnummer Part number	P	E	r	Größe Size	TH35
RS274.0102.01.E	0,25	0,20	0,04	04	Δ
RS274.0203.01.E	0,35	0,25	0,05	04	Δ
RS274.0204.01.E	0,40	0,30	0,06	04	Δ

▲ ab Lager / on stock Δ 4 Wochen / 4 weeks x auf Anfrage / upon request

● empfohlen / recommended

o bedingt einsetzbar / alternative recommendation

- nicht geeignet / not suitable

■ unbeschichtete HM-Sorten / uncoated grades

■ beschichtete HM-Sorten / coated grades

■ bestückt/Cermet / brazed/Cermet

Abmessungen in mm

Dimensions in mm

Keine Unterlegplatte erforderlich. Sämtliche HORN-Gewindeprofile sind mit einem **KEGELMANTEL-FREISCHLIFF** versehen.

No shims necessary. All HORN thread profiles are manufactured with **full ground radial clearance**.

P	•
M	•
K	•
N	•
S	•
H	-

HM-Sorten
Carbide grades



Gewindedrehen (außen) Vollprofil

Threading (external) Full profile



Wendeschneidplatte

Indexable insert

S274...E

Metrisches ISO-Gewinde
Metric ISO thread

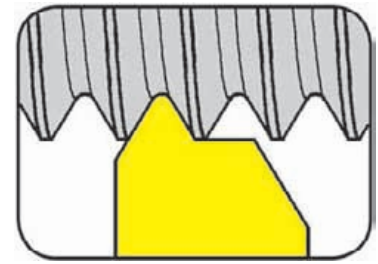

Steigung	Pitch	0,5-1,5 mm
----------	-------	------------

präzisionsgeschliffen
precision ground

für Klemmhalter
for Toolholder

Typ H274...E
Type

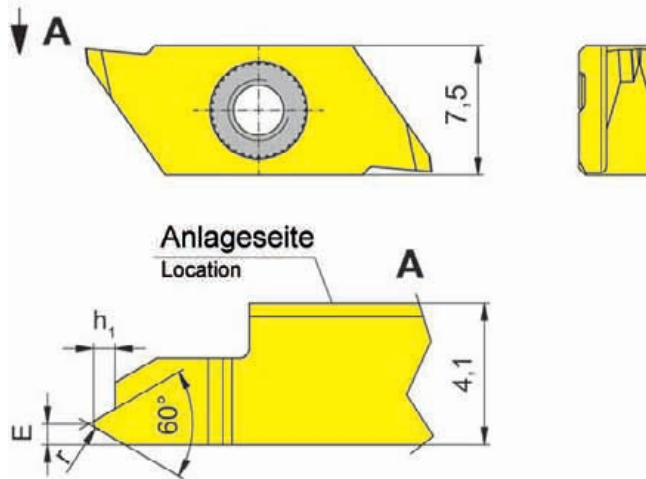

R = rechts wie gezeichnet
R = right hand version shown

L = links spiegelbildlich
L = left hand version

Wechselgenauigkeit
Länge $\pm 0,015$ mm
Indexability length
 $\pm 0,015$ mm

Bestellnummer Part number	P	E	r	h_1	Größe Size	TH35
R/LS274.0305.02.E	0,50	0,40	0,07	0,31	04	ΔΔ
R/LS274.0306.02.E	0,60	0,45	0,09	0,37	04	ΔΔ
R/LS274.0307.02.E	0,70	0,50	0,10	0,43	04	ΔΔ
R/LS274.0407.02.E	0,75	0,50	0,11	0,46	04	ΔΔ
R/LS274.0408.02.E	0,80	0,55	0,12	0,49	04	ΔΔ
R/LS274.0610.02.E	1,00	0,60	0,14	0,61	04	ΔΔ
R/LS274.0712.02.E	1,25	0,70	0,15	0,77	04	ΔΔ
R/LS274.0915.02.E	1,50	0,80	0,20	0,92	04	ΔΔ

▲ ab Lager / on stock Δ 4 Wochen / 4 weeks x auf Anfrage / upon request

● empfohlen / recommended

o bedingt einsetzbar / alternative recommendation

- nicht geeignet / not suitable

■ unbeschichtete HM-Sorten / uncoated grades

■ beschichtete HM-Sorten / coated grades

■ bestückt/Cermet / brazed/Cermet

Abmessungen in mm

Dimensions in mm

Ausführung R oder L angeben

State R or L version

Keine Unterlegplatte erforderlich. Sämtliche HORN-Gewindeprofile sind mit einem **KEGELMANTEL-FREISCHLIFF** versehen.
No shims necessary. All HORN thread profiles are manufactured with **full ground radial clearance**.

P	•
M	•
K	•
N	•
S	•
H	-

HM-Sorten
Carbide grades

Gewindedrehen (außen) Vollprofil

Threading (external) Full profile



Wendeschneidplatte

Indexable insert

S274...E

Metrisches ISO-Gewinde
Metric ISO thread

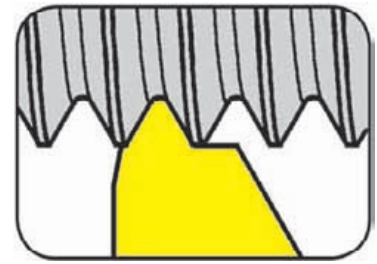

Steigung	Pitch	0,5-1,5 mm
----------	-------	------------

präzisionsgeschliffen
precision ground

für Klemhalter
for Toolholder

Typ H274...E
Type

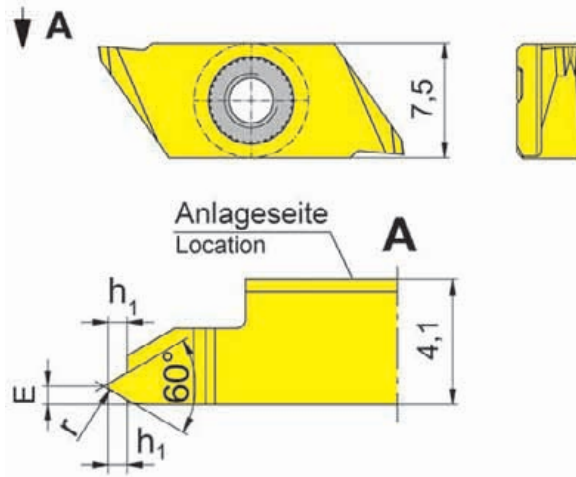

R = rechts wie gezeichnet
R = right hand version shown

L = links spiegelbildlich
L = left hand version

Wechselgenauigkeit
Länge ± 0,015 mm
Indexability length
± 0,015 mm

Bestellnummer Part number	P	E	r	h ₁	Größe Size	TH35
R/LS274.0305.03.E	0,50	0,40	0,07	0,31	04	ΔΔ
R/LS274.0306.03.E	0,60	0,45	0,09	0,37	04	ΔΔ
R/LS274.0307.03.E	0,70	0,50	0,10	0,43	04	ΔΔ
R/LS274.0407.03.E	0,75	0,50	0,11	0,46	04	ΔΔ
R/LS274.0408.03.E	0,80	0,55	0,12	0,49	04	ΔΔ
R/LS274.0610.03.E	1,00	0,60	0,14	0,61	04	ΔΔ
R/LS274.0712.03.E	1,25	0,70	0,15	0,77	04	ΔΔ
R/LS274.0915.03.E	1,50	0,80	0,20	0,92	04	ΔΔ

- ▲ ab Lager / on stock Δ 4 Wochen / 4 weeks x auf Anfrage / upon request
- empfohlen / recommended
- o bedingt einsetzbar / alternative recommendation
- nicht geeignet / not suitable
- unbeschichtete HM-Sorten / uncoated grades
- beschichtete HM-Sorten / coated grades
- bestückt/Cermet / brazed/Cermet

P	•
M	•
K	•
N	•
S	•
H	-

Abmessungen in mm
Dimensions in mm

HM-Sorten
Carbide grades

Ausführung R oder L angeben
State R or L version

Keine Unterlegplatte erforderlich. Sämtliche HORN-Gewindeprofile sind mit einem **KEGELMANTEL-FREISCHLIFF** versehen.
No shims necessary. All HORN thread profiles are manufactured with **full ground radial clearance**.



Einstecken und Drehen

Grooving and Turning



Klemmhalter

Toolholder

H274...SF

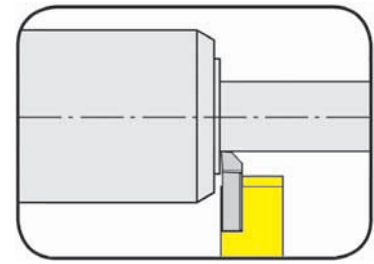

Stechtiefe bis
Stechbreite

Depth of groove up to
Width of groove

6 mm
0,5 - 2,0 mm

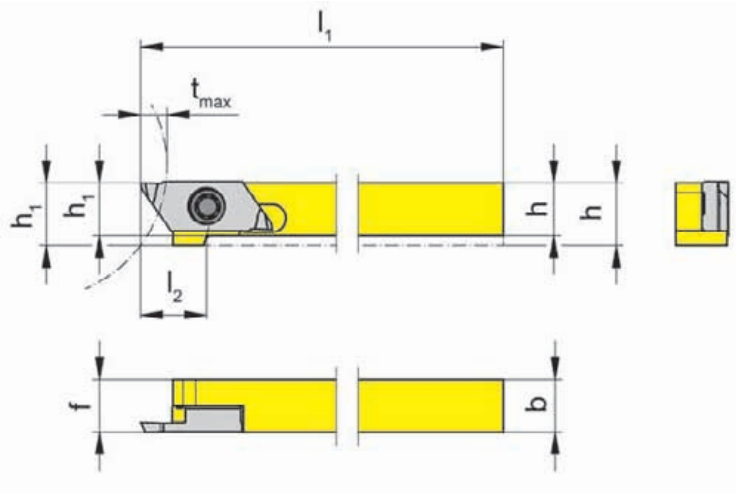

für Klemmhalter
for Toolholder

Typ S274...SF
Type

R = rechts wie gezeichnet
R = right hand version shown

L = links spiegelbildlich
L = left hand version

Bestellnummer Part number	h	b	l ₁	l ₂	h ₁	t _{max}	f	Größe Size
RH274.0808.SF.04	8	8	100	10	9,5	6	8	04
RH274.1010.SF.04	10	10	100	-	10,0	6	10	04
RH274.1212.SF.04	12	12	100	-	12,0	6	12	04

Weitere Abmessungen auf Anfrage
Further sizes upon request

Abmessungen in mm
Dimensions in mm

t_{max} 6 mm nur bei Werkstück-Ø ≤ 25 mm erreichbar.
t_{max} 6 mm can be reached only with workpiece Ø ≤ 25 mm.

Das Anzugsdrehmoment der Schrauben finden Sie in den Technischen Hinweisen.
For torque specification of the screw, please see Technical Instructions.

L

Ersatzteile

Spare Parts

Klemmhalter Toolholder	Spannschraube Screw	TORX PLUS®-Schlüssel TORX PLUS® Wrench
RH274...	030.350P.0852	T15PQ

Einstecken und Drehen

Grooving and Turning



Klemmhalter

Toolholder

H274...SF

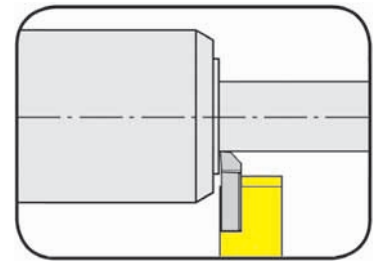

Stechtiefe	Depth of groove	6 mm
Stechbreite	Width of groove	0,5 - 2,0 mm

Schaftmaterial: Schwermetall (schwingungsarm)
 Material of shank: tungsten alloy (giving good vibration resistance)

für Klemmhalter
 for Toolholder

Typ S274...SF
 Type

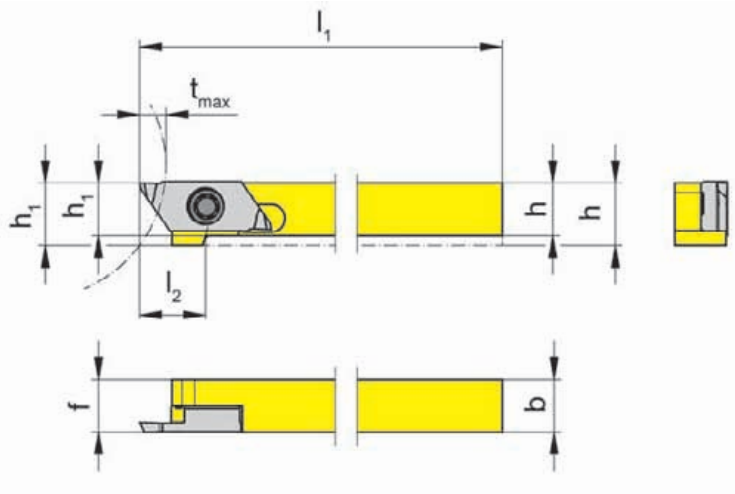

R = rechts wie gezeichnet
 R = right hand version shown

L = links spiegelbildlich
 L = left hand version

Bestellnummer Part number	h	b	l ₁	l ₂	h ₁	t _{max}	f	Größe Size
RH274.0808.SF.S4	8	8	100	10	9,5	6	8	04
RH274.1010.SF.S4	10	10	100	-	10,0	6	10	04
RH274.1212.SF.S4	12	12	100	-	12,0	6	12	04

Weitere Abmessungen auf Anfrage
 Further sizes upon request

Abmessungen in mm
 Dimensions in mm

t_{max} 6 mm nur bei Werkstück-Ø ≤ 25 mm erreichbar.
 t_{max} 6 mm can be reached only with workpiece Ø ≤ 25 mm.

Das Anzugsdrehmoment der Schrauben finden Sie in den Technischen Hinweisen.
 For torque specification of the screw, please see Technical Instructions.

Ersatzteile

Spare Parts

Klemmhalter Toolholder	Spannschraube Screw	TORX PLUS®-Schlüssel TORX PLUS® Wrench
RH274...	030.350P.0852	T15PQ



Längsdrehen

Side Turning



Wendeschneidplatte

Indexable insert

S274

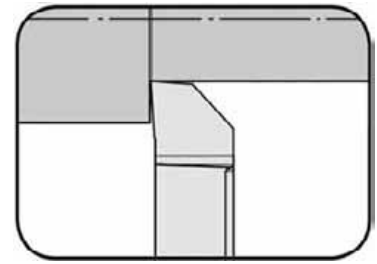

Schnitttiefe bis	Depth of cut up to	2,5 mm
------------------	--------------------	--------

präzisionsgeschliffen
precision ground

für Klemhalter
for Toolholder

Typ H274...SF
Type

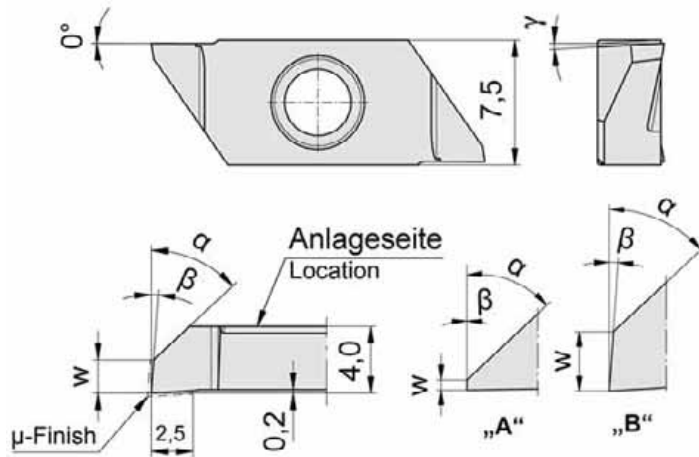

R = rechts wie gezeichnet
R = right hand version shown

L = links spiegelbildlich
L = left hand version

Wechselgenauigkeit
Länge ± 0,015 mm
Indexability length
± 0,015 mm

Bestellnummer Part number	w	γ	α	Form Form	β	Größe Size	MG12	AC25	AC2P
RS274.0547.04.SF	0,05	0°	47°	A	0°	04	○	●	●
R/LS274.2047.03.SF	2,00	3°	47°	B	4°	04	▲/△	▲/▲	▲/▲

▲ ab Lager / on stock Δ 4 Wochen / 4 weeks x auf Anfrage / upon request

● empfohlen / recommended

○ bedingt einsetzbar / alternative recommendation

- nicht geeignet / not suitable

□ unbeschichtete HM-Sorten / uncoated grades

■ beschichtete HM-Sorten / coated grades

■ bestückt/Cermet / brazed/Cermet

Abmessungen in mm

Dimensions in mm

P	○	●	●
M	●	●	○
K	●	●	-
N	●	○	-
S	●	●	-
H	-	-	-

HM-Sorten
Carbide grades

Kopierdrehen (Schlichten)

Copy Turning (Finishing)



Wendeschneidplatte

Indexable insert

S274...SF

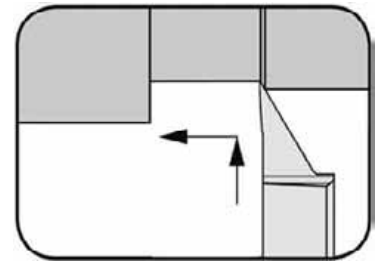

Schnitttiefe bis	Depth of cut up to	2,5 mm
------------------	--------------------	--------

präzisionsgeschliffen
precision ground

für Klemhalter
for Toolholder

Typ H274...SF
Type

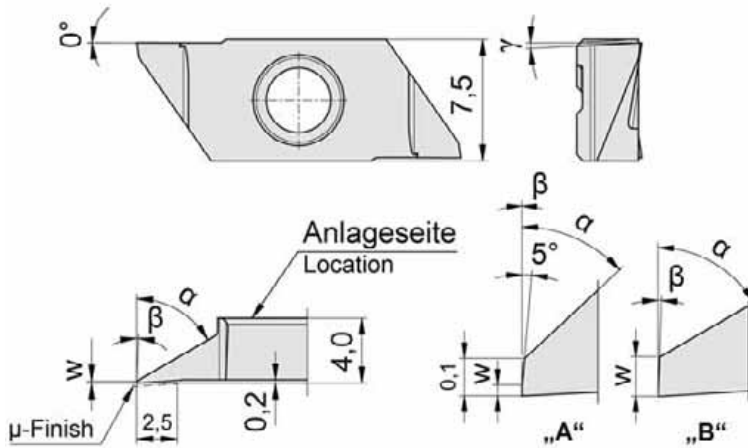

R = rechts wie gezeichnet
R = right hand version shown

L = links spiegelbildlich
L = left hand version

Wechselgenauigkeit
Länge ± 0,015 mm
Indexability length
± 0,015 mm

Bestellnummer Part number	w	γ	α	Form Form	β	Größe Size	MG12	AC25	AC2P
RS274.0147.04.SF	0,030	0°	47°	A	0°	04	○	●	●
R/LS274.0160.03.SF	0,105	3°	60°	B	2°	04	▲/△	▲/△	▲/▲

▲ ab Lager / on stock Δ 4 Wochen / 4 weeks x auf Anfrage / upon request

● empfohlen / recommended

○ bedingt einsetzbar / alternative recommendation

- nicht geeignet / not suitable

□ unbeschichtete HM-Sorten / uncoated grades

■ beschichtete HM-Sorten / coated grades

■ bestückt/Cermet / brazed/Cermet

Abmessungen in mm

Dimensions in mm

	MG12	AC25	AC2P
P	○	●	●
M	●	●	○
K	●	●	-
N	●	○	-
S	●	●	-
H	-	-	-

HM-Sorten
Carbide grades



Kopierdrehen (Schlichten)

Copy Turning (Finishing)



Wendeschneidplatte

Indexable insert

S274...SF

Schnitttiefe bis	Depth of cut up to	4 mm
------------------	--------------------	------

präzisionsgeschliffen
precision ground

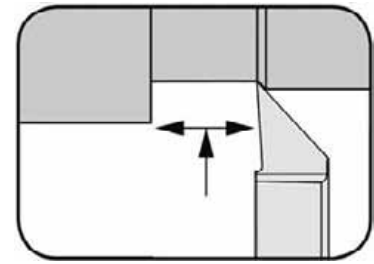

für Klemhalter
for Toolholder

Typ H274...SF
Type

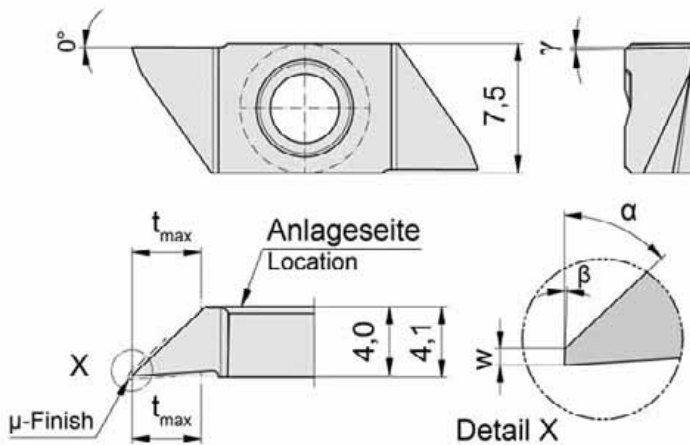

R = rechts wie gezeichnet
R = right hand version shown

Wechselgenauigkeit
Länge ± 0,015 mm
Indexability length
± 0,015 mm

Bestellnummer Part number	w	t _{max}	γ	α	β	Größe Size	AC25	AC2P
RS274.0247.04.SF	0,025	4	1,5°	47°	2°	04	▲	▲

▲ ab Lager / on stock Δ 4 Wochen / 4 weeks x auf Anfrage / upon request

● empfohlen / recommended

o bedingt einsetzbar / alternative recommendation

- nicht geeignet / not suitable

■ unbeschichtete HM-Sorten / uncoated grades

■ beschichtete HM-Sorten / coated grades

■ bestückt/Cermet / brazed/Cermet

Abmessungen in mm

Dimensions in mm

P	●	●
M	●	o
K	●	-
N	o	-
S	●	-
H	-	-

HM-Sorten
Carbide grades

Abstechen

Parting Off



Wendeschneidplatte

Indexable insert

S274...SF

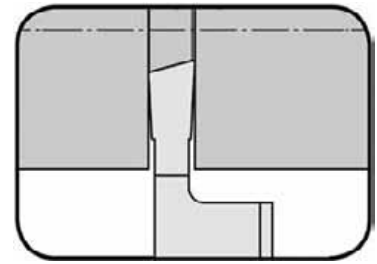

Stechtiefe bis Stechbreite	Depth of groove up to Width of groove	6 mm 0,8-1,5 mm
-------------------------------	--	--------------------

präzisionsgeschliffen
precision ground

für Klemhalter
for Toolholder

Typ H274...SF
Type

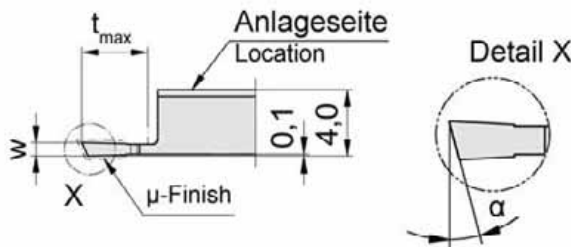
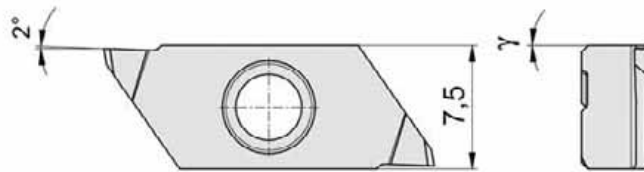

R = rechts wie gezeichnet
R = right hand version shown

L = links spiegelbildlich
L = left hand version

Wechselgenauigkeit
Länge ± 0,015 mm
Indexability length
± 0,015 mm

Bestellnummer Part number	w	t _{max}	α	γ	Größe Size	MG12	AC25	AC2P
R/LS274.2508.04.SF	0,8	4	25°	0°	04	▲/Δ	▲/Δ	▲/▲
RS274.2509.04.SF	0,9	4	25°	0°	04		▲	▲
RS274.2510.04.SF	1,0	4	25°	0°	04		▲	▲
RS274.2510.06.SF	1,0	6	25°	0°	04		▲	▲
RS274.2512.06.SF	1,2	6	25°	0°	04		▲	▲
RS274.2515.06.SF	1,5	6	25°	0°	04		▲	▲

▲ ab Lager / on stock Δ 4 Wochen / 4 weeks x auf Anfrage / upon request

● empfohlen / recommended

o bedingt einsetzbar / alternative recommendation

- nicht geeignet / not suitable

■ unbeschichtete HM-Sorten / uncoated grades

■ beschichtete HM-Sorten / coated grades

■ bestückt/Cermet / brazed/Cermet

Abmessungen in mm

Dimensions in mm

t_{max} 6 mm nur bei Werkstück-Ø ≤ 25 mm erreichbar.

t_{max} 6 mm can be reached only with workpiece Ø ≤ 25 mm.

P	o	•	•
M	•	•	o
K	•	•	-
N	•	o	-
S	•	•	-
H	-	-	-

HM-Sorten
Carbide grades



Abstechen

Parting Off



Wendeschneidplatte

Indexable insert

S274...SF

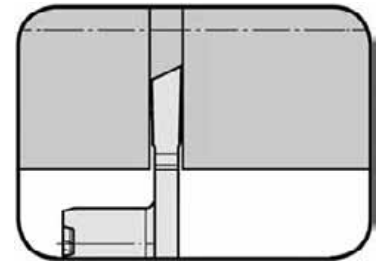

Stechtiefe bis Stechbreite	Depth of groove up to Width of groove	6 mm 0,8-1,5 mm
-------------------------------	--	--------------------

präzisionsgeschliffen
precision ground

für Klemmhalter
for Toolholder

Typ H274...SF
Type

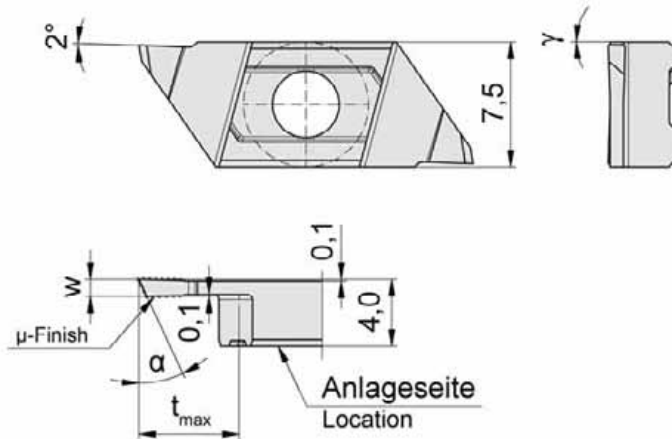

L = links wie gezeichnet
L = left hand version shown

Wechselgenauigkeit
Länge ± 0,015 mm
Indexability length
± 0,015 mm

Bestellnummer Part number	w	t _{max}	α	γ	Größe Size	AC25	AC2P
LS274.2508.04.SF.R	0,8	4	25°	0°	04	▲	▲
LS274.2509.04.SF.R	0,9	4	25°	0°	04	▲	▲
LS274.2510.06.SF.R	1,0	6	25°	0°	04	▲	▲
LS274.2512.06.SF.R	1,2	6	25°	0°	04	▲	▲
LS274.2515.06.SF.R	1,5	6	25°	0°	04	▲	▲

▲ ab Lager / on stock Δ 4 Wochen / 4 weeks x auf Anfrage / upon request

● empfohlen / recommended

o bedingt einsetzbar / alternative recommendation

- nicht geeignet / not suitable

■ unbeschichtete HM-Sorten / uncoated grades

■ beschichtete HM-Sorten / coated grades

■ bestückt/Cermet / brazed/Cermet

Abmessungen in mm

Dimensions in mm

t_{max} 6 mm nur bei Werkstück-Ø ≤ 25 mm erreichbar.

t_{max} 6 mm can be reached only with workpiece Ø ≤ 25 mm.

P	●	●
M	●	○
K	●	-
N	○	-
S	●	-
H	-	-

HM-Sorten
Carbide grades

Einstecken/Rückwärtsdrehen

Grooving/Backturning



Wendeschneidplatte

Indexable insert

S274...SF

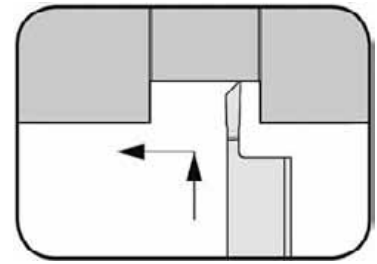

Stechtiefe bis Stechbreite	Depth of groove up to Width of groove	6 mm 0,8-1,8 mm
-------------------------------	--	--------------------

präzisionsgeschliffen
precision ground

für Klemhalter
for Toolholder

Typ H274...SF
Type

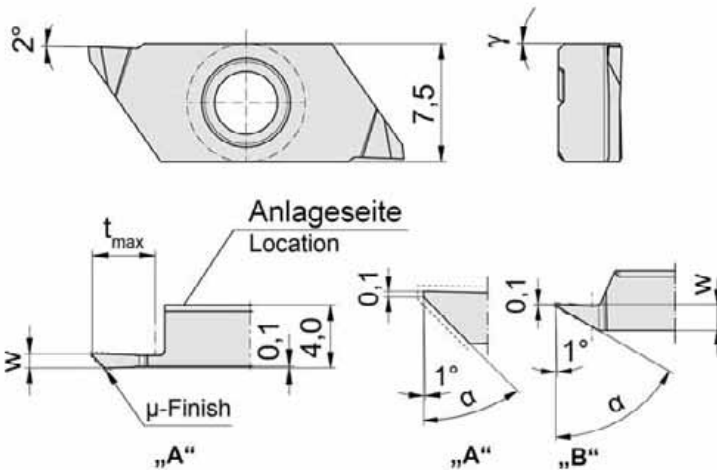

R = rechts wie gezeichnet
R = right hand version shown

L = links spiegelbildlich
L = left hand version

Wechselgenauigkeit
Länge ± 0,015 mm
Indexability length
± 0,015 mm

Bestellnummer Part number	w	t _{max}	α	γ	Form Form	Größe Size	MG12	AC25	AC2P
RS274.4508.04.SF	0,8	4,0	45°	0°	A	04		▲	▲
R/LS274.4509.04.SF	0,9	4,0	45°	0°	A	04	▲/▲	▲/▲	▲/▲
RS274.4510.06.SF	1,0	6,0	45°	0°	A	04		▲	▲
RS274.4512.06.SF	1,2	6,0	45°	0°	A	04		▲	▲
RS274.6015.02.SF	1,8	2,5	60°	0°	B	04		▲	▲
RS274.7010.02.SF	1,2	2,5	70°	0°	B	04		▲	▲

▲ ab Lager / on stock Δ 4 Wochen / 4 weeks x auf Anfrage / upon request

● empfohlen / recommended

o bedingt einsetzbar / alternative recommendation

- nicht geeignet / not suitable

■ unbeschichtete HM-Sorten / uncoated grades

■ beschichtete HM-Sorten / coated grades

■ bestückt/Cermet / brazed/Cermet

Abmessungen in mm

Dimensions in mm

t_{max} 6 mm nur bei Werkstück-Ø ≤ 25 mm erreichbar.

t_{max} 6 mm can be reached only with workpiece Ø ≤ 25 mm.

P	○	●	●
M	●	●	○
K	●	●	-
N	●	○	-
S	●	●	-
H	-	-	-

HM-Sorten
Carbide grades



Einstecken/Rückwärtsdrehen

Grooving/Backturning



Wendeschneidplatte

Indexable insert

S274...SF

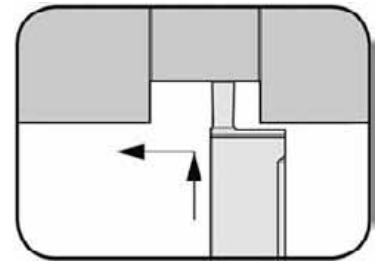

Stechtiefe bis Stechbreite	Depth of groove up to Width of groove	3 mm 0,5-2 mm
-------------------------------	--	------------------

präzisionsgeschliffen
precision ground

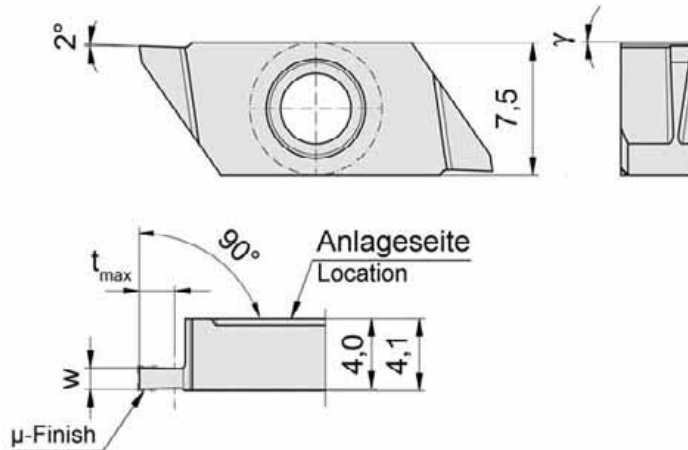

für Klemhalter
for Toolholder

Typ H274...SF
Type

Wechselgenauigkeit
Länge ± 0,015 mm
Indexability length
± 0,015 mm

R = rechts wie gezeichnet
R = right hand version shown

Bestellnummer Part number	w	t _{max}	γ	Größe Size	AC25	AC2P
RS274.0005.01.SF	0,5	1	0°	04	▲	▲
RS274.0010.02.SF	1,0	2	0°	04	▲	▲
RS274.0012.02.SF	1,2	2	0°	04	▲	▲
RS274.0015.03.SF	1,5	3	0°	04	▲	▲
RS274.0020.03.SF	2,0	3	0°	04	▲	▲

▲ ab Lager / on stock Δ 4 Wochen / 4 weeks x auf Anfrage / upon request

● empfohlen / recommended

o bedingt einsetzbar / alternative recommendation

- nicht geeignet / not suitable

■ unbeschichtete HM-Sorten / uncoated grades

■ beschichtete HM-Sorten / coated grades

■ bestückt/Cermet / brazed/Cermet

Abmessungen in mm

Dimensions in mm

P	●	●
M	●	o
K	●	-
N	o	-
S	●	-
H	-	-

HM-Sorten
Carbide grades

34T



**Klemmhalter mit
Schneidplatten**

Stechbreite 2 - 5 mm

**Toolholder with
Inserts**

Width of groove 2 - 5 mm

Klemmhalter
Toolholder
H34T

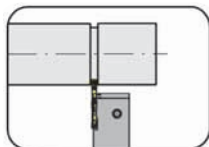

Seite/Page
M3

Wendeschneidplatte
Indexable insert
S34T

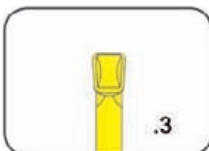

Seite/Page
M4

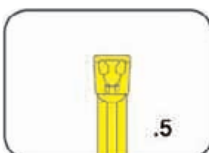

Seite/Page
M5

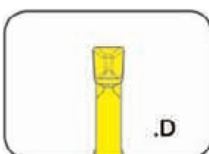

Seite/Page
M6

Einstecken (außen)

Grooving (external)



Klemmhalter

Toolholder

H34T

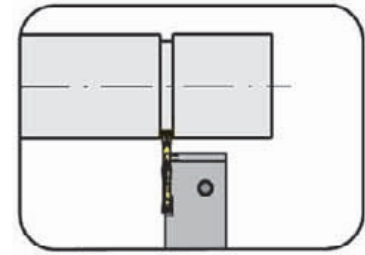

Stechtiefe bis
Spannbereich

Depth of groove up to
Clamping range

6,5 mm
2,00 - 4,01 mm

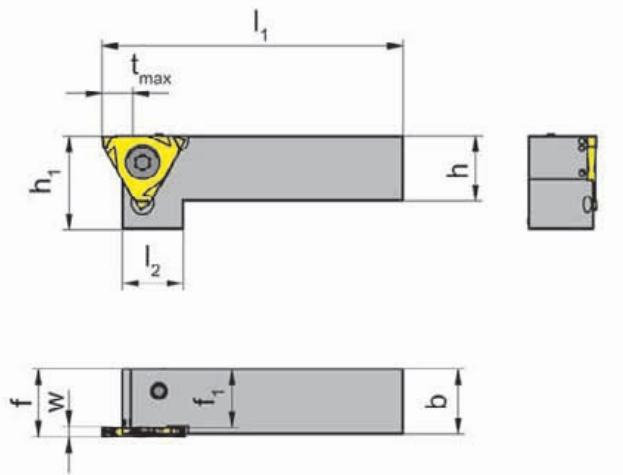

R = rechts wie gezeichnet
R = right hand version shown

L = links spiegelbildlich
L = left hand version

für Wendeschneidplatte
for Indexable insert

Typ S34T
Type

mit innerer
Kühlmittelzufuhr
with through coolant supply

Bestellnummer Part number	h	b	l ₁	l ₂	h ₁	f	f ₁	t _{max}	Größe Size	Spannbereich Clamping range
R/LH34T.1616.4.10.IK	16	16	69	15	21	f ₁ +w-a ₁	14,5	6,5	01	2,00-2,00
R/LH34T.2020.4.10.IK	20	20	84	15	25	f ₁ +w-a ₁	18,5	6,5	01	2,00-2,00
R/LH34T.2525.4.10.IK	25	25	99	15	30	f ₁ +w-a ₁	23,5	6,5	01	2,00-2,00
R/LH34T.1616.4.20.IK	16	16	69	15	21	f ₁ +w-a ₁	13,5	6,5	02	2,01-3,00
R/LH34T.2020.4.20.IK	20	20	84	15	25	f ₁ +w-a ₁	17,5	6,5	02	2,01-3,00
R/LH34T.2525.4.20.IK	25	25	99	15	30	f ₁ +w-a ₁	22,5	6,5	02	2,01-3,00
R/LH34T.2020.4.30.IK	20	20	84	15	25	f ₁ +w-a ₁	16,5	6,5	03	3,01-4,00
R/LH34T.2525.4.30.IK	25	25	99	15	30	f ₁ +w-a ₁	21,5	6,5	03	3,01-4,00
R/LH34T.2020.4.40.IK	20	20	84	15	25	f ₁ +w-a ₁	15,5	6,5	04	4,01-4,01
R/LH34T.2525.4.40.IK	25	25	99	15	30	f ₁ +w-a ₁	20,5	6,5	04	4,01-4,01

Ausführung R oder L angeben
State R or L version

w siehe WSP
w see indexable inserts

Abmessungen in mm
Dimensions in mm

Das Anzugsdrehmoment der Schrauben finden Sie in den Technischen Hinweisen.
For torque specification of the screw, please see Technical Instructions.

Ersatzteile

Spare Parts

Klemmhalter Toolholder	Spannschraube Screw	TORX PLUS®-Schlüssel TORX PLUS® Wrench
R/LH34T...10.IK	030.4093.T15P	T15PQ
R/LH34T...20.IK	030.4010.T15P	T15PQ
R/LH34T...30.IK	030.5012.T15P	T15PQ
R/LH34T...40.IK	030.5012.T20P	T20PQ

Einstechen und Abstechen

Grooving and Parting Off



Wendeschneidplatte

Indexable insert

S34T

mit gesinterter Geometrie
with sintered geometries

Stechbreite	Width of groove	2-5 mm
-------------	-----------------	--------

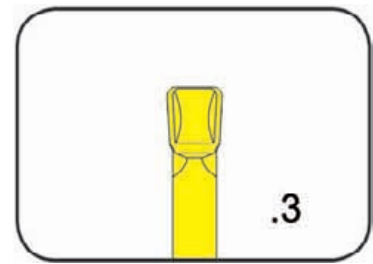

für Klemmhalter
for Toolholder

Typ H34T
Type

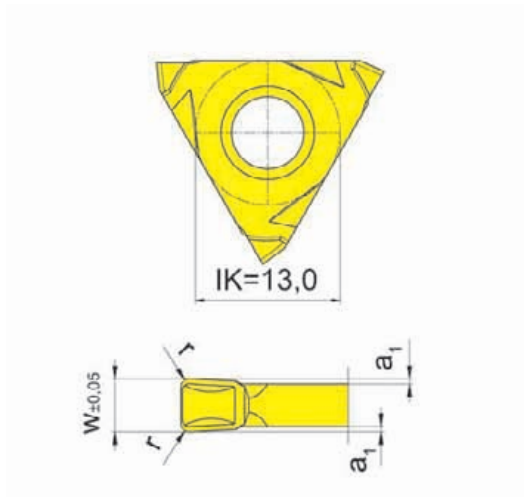

Geometrie .3
Geometry .3

Bestellnummer Part number	w	r	a ₁	Größe Size	AS45
S34T.0200.32	2,0	0,2	0,25	01	▲
S34T.0200.34	2,0	0,4	0,25	01	▲
S34T.0250.32	2,5	0,2	0,25	02	▲
S34T.0250.34	2,5	0,4	0,25	02	▲
S34T.0300.32	3,0	0,2	0,25	02	▲
S34T.0300.34	3,0	0,4	0,25	02	▲
S34T.0400.32	4,0	0,2	0,25	03	▲
S34T.0500.32	5,0	0,2	0,25	04	▲
S34T.0500.34	5,0	0,4	0,25	04	▲

▲ ab Lager / on stock Δ 4 Wochen / 4 weeks x auf Anfrage / upon request

● empfohlen / recommended

o bedingt einsetzbar / alternative recommendation

- nicht geeignet / not suitable

■ unbeschichtete HM-Sorten / uncoated grades

■ beschichtete HM-Sorten / coated grades

■ bestückt/Cermet / brazed/Cermet

Abmessungen in mm

Dimensions in mm

Wendeschneidplatten sind in rechten und linken Klemmhaltern verwendbar.

Indexable inserts can be used in right and left hand toolholders.

P	•
M	•
K	•
N	o
S	•
H	-

HM-Sorten
Carbide grades

Einstechen und Abstechen

Grooving and Parting Off



Wendeschneidplatte

Indexable insert

S34T

mit gesinterter Geometrie
with sintered geometries

Stechbreite	Width of groove	2,5-5 mm
-------------	-----------------	----------

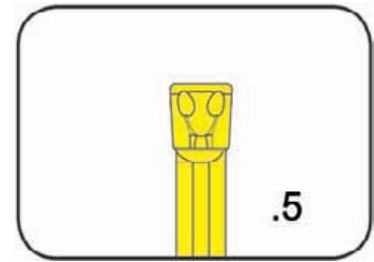

für Klemmhalter
for Toolholder

Typ H34T
Type

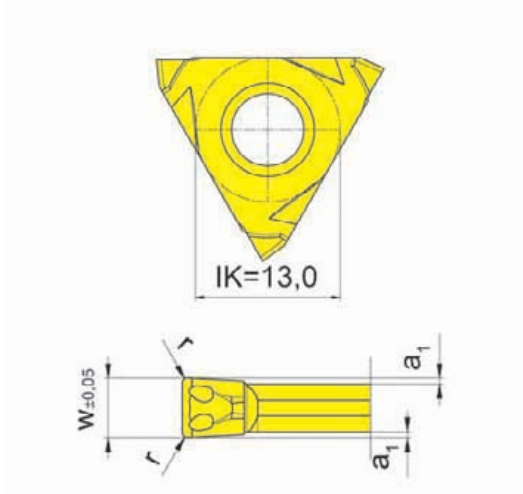

Geometrie .5
Geometry .5

Bestellnummer Part number	w	r	a ₁	Größe Size	AS45
S34T.0250.52	2,5	0,2	0,25	02	▲
S34T.0250.54	2,5	0,4	0,25	02	▲
S34T.0300.52	3,0	0,2	0,25	02	▲
S34T.0300.54	3,0	0,4	0,25	02	▲
S34T.0400.52	4,0	0,2	0,25	03	▲
S34T.0400.54	4,0	0,4	0,25	03	▲
S34T.0500.52	5,0	0,2	0,25	04	▲
S34T.0500.54	5,0	0,4	0,25	04	▲

▲ ab Lager / on stock Δ 4 Wochen / 4 weeks x auf Anfrage / upon request

● empfohlen / recommended

o bedingt einsetzbar / alternative recommendation

- nicht geeignet / not suitable

■ unbeschichtete HM-Sorten / uncoated grades

■ beschichtete HM-Sorten / coated grades

■ bestückt/Cermet / brazed/Cermet

Abmessungen in mm

Dimensions in mm

Wendeschneidplatten sind in rechten und linken Klemmhaltern verwendbar.

Indexable inserts can be used in right and left hand toolholders.

P	●
M	●
K	●
N	○
S	●
H	-

HM-Sorten
Carbide grades

Einstechen und Abstechen

Grooving and Parting Off



Wendeschneidplatte

Indexable insert

S34T

mit gesinterter Geometrie
with sintered geometries

Stechbreite	Width of groove	2-3 mm
-------------	-----------------	--------

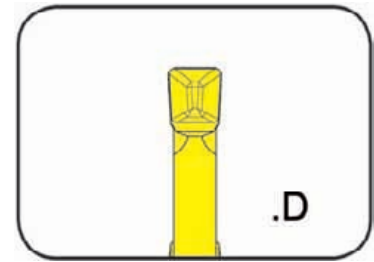

für Klemmhalter
for Toolholder

Typ H34T
Type

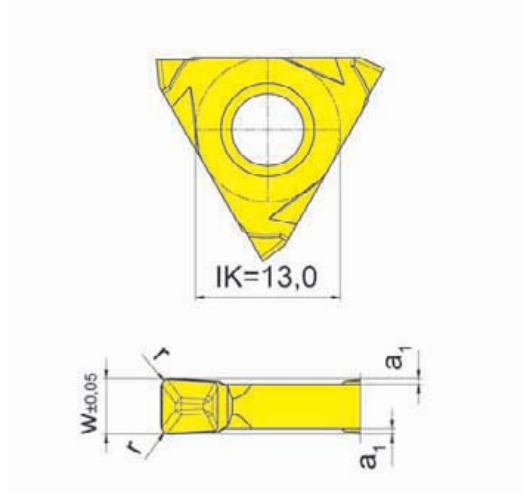

Geometrie .D
Geometry .D

Bestellnummer Part number	w	r	a ₁	Größe Size	AS45
S34T.0200.D2	2,0	0,2	0,25	01	▲
S34T.0200.D4	2,0	0,4	0,25	01	▲
S34T.0250.D2	2,5	0,2	0,25	02	▲
S34T.0250.D4	2,5	0,4	0,25	02	▲
S34T.0300.D2	3,0	0,2	0,25	02	▲
S34T.0300.D4	3,0	0,4	0,25	02	▲

▲ ab Lager / on stock Δ 4 Wochen / 4 weeks x auf Anfrage / upon request

● empfohlen / recommended

o bedingt einsetzbar / alternative recommendation

- nicht geeignet / not suitable

■ unbeschichtete HM-Sorten / uncoated grades

■ beschichtete HM-Sorten / coated grades

■ bestückt/Cermet / brazed/Cermet

Abmessungen in mm

Dimensions in mm

Wendeschneidplatten sind in rechten und linken Klemmhaltern verwendbar.

Indexable inserts can be used in right and left hand toolholders.

P	●
M	●
K	●
N	○
S	●
H	-

HM-Sorten
Carbide grades

312



**Klemmhalter mit
Schneidplatten**

Stechbreite 0,5 - 6,3 mm

**Toolholder with
Inserts**

Width of groove 0,5 - 6,3 mm

Klemmhalter
Toolholder
360/361/369/390/
391/368/309/340

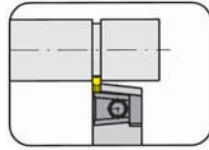

Seite/Page
N4-N8, N18-N19

Einstellbare Halter
Adjustable holder
N67/N68/N69



Seite/Page
N17

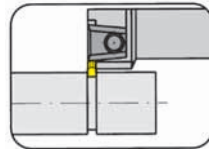

Seite/Page
N13

Grundhalter
Basic toolholder
330

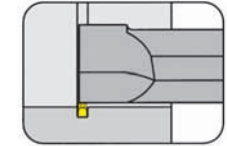

Seite/Page
N23

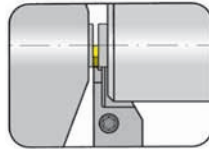

Seite/Page
N9-N10

Wendeschneidplatte
Indexable insert
S312/312

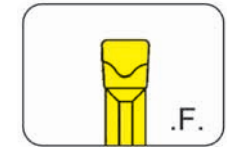

Seite/Page
N24

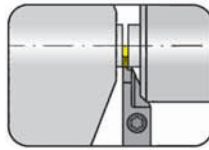

Seite/Page
N11-N12

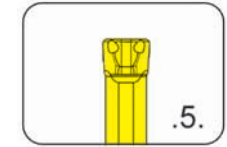

Seite/Page
N25



Seite/Page
N14

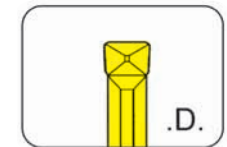

Seite/Page
N26

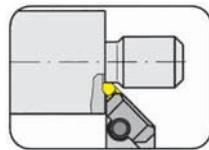

Seite/Page
N20

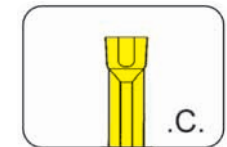

Seite/Page
N27

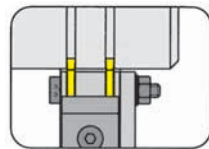

Seite/Page
N21-N22

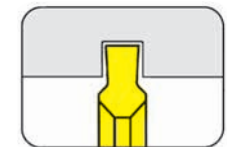

Seite/Page
N28-N32

Einbauhalter Graf
Cartridge Graf
64/65/99



Seite/Page
N15-N16

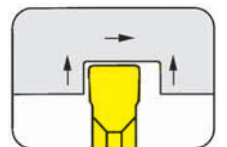

Seite/Page
N33

Wendeschneidplatte
Indexable insert
S312/312

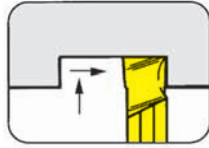

Seite/Page
N34

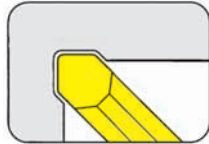

Seite/Page
N35-N36

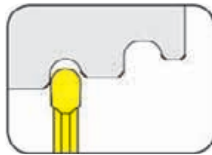

Seite/Page
N37

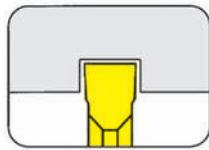

Seite/Page
N38-N39

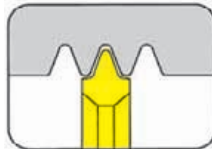

Seite/Page
N40

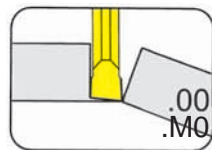

Seite/Page
N41-N44

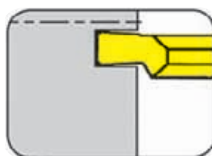

Seite/Page
N45

Einstecken und Abstecken

Grooving and Parting Off



Klemmhalter

Toolholder

360

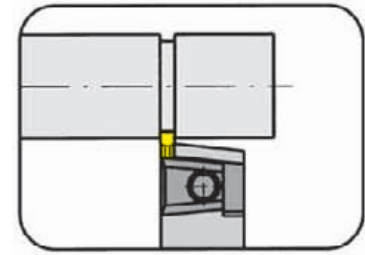

Stechtiefe bis
Spannbereich

Depth of groove up to
Clamping range

6 mm
0,5 - 2,9 mm

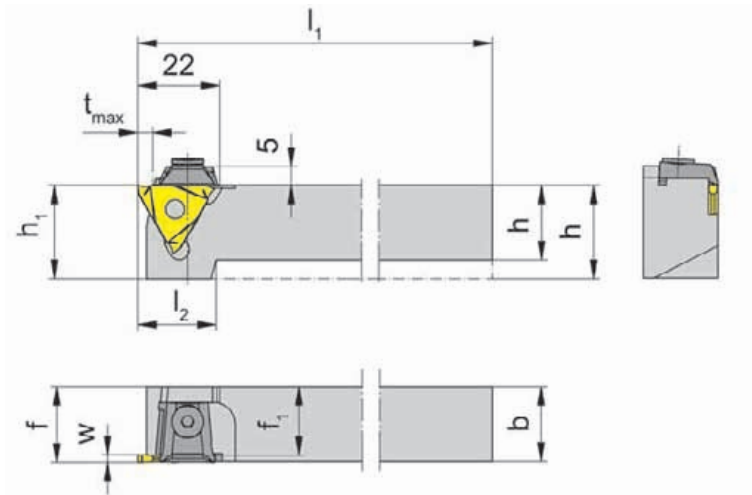

für Wendeschneidplatte
for Indexable insert

Typ 312
Type S312
N312

R = rechts wie gezeichnet
R = right hand version shown

L = links spiegelbildlich
L = left hand version

Bestellnummer Part number	h	b	l ₁	l ₂	h ₁	f	f ₁	t _{max}	Größe Size	Spannbereich Clamping range
R/L360.1212.01	12	12	100	24	25	f ₁ +w-a ₁	10,5	4	01	0,5-1,9
R/L360.1616.01	16	16	125	22	25	f ₁ +w-a ₁	14,5	4	01	0,5-1,9
R/L360.2020.01	20	20	125	21	25	f ₁ +w-a ₁	18,5	4	01	0,5-1,9
R/L360.2525.01	25	25	150	-	25	f ₁ +w-a ₁	23,5	4	01	0,5-1,9
R/L360.3232.01	32	32	170	-	32	f ₁ +w-a ₁	30,5	4	01	0,5-1,9
R/L360.1212.02	12	12	100	24	25	f ₁ +w-a ₁	9,5	6	02	1,9-2,9
R/L360.1616.02	16	16	125	22	25	f ₁ +w-a ₁	13,5	6	02	1,9-2,9
R/L360.2020.02	20	20	125	21	25	f ₁ +w-a ₁	17,5	6	02	1,9-2,9
R/L360.2525.02	25	25	150	-	25	f ₁ +w-a ₁	22,5	6	02	1,9-2,9
R/L360.3232.02	32	32	170	-	32	f ₁ +w-a ₁	29,5	6	02	1,9-2,9

Ausführung R oder L angeben
State R or L version

w, a₁ siehe WSP
w, a₁ see indexable inserts

Abmessungen in mm
Dimensions in mm

Weitere Abmessungen auf Anfrage
Further sizes upon request

t_{max} nur bei Werkstück-Ø ≤ 40 mm erreichbar.
t_{max} can be reached only with workpiece Ø ≤ 40 mm

Das Anzugsdrehmoment der Schrauben finden Sie in den Technischen Hinweisen.
For torque specification of the screw, please see Technical Instructions.

Ersatzteile

Spare Parts

Klemmhalter Toolholder	Inbus-Schlüssel Wrench	Spannelement Clamping element
R/L360.1...	SW3,0 DIN911	11.3
R/L360...	SW3,0 DIN911	16.4

Einstecken und Abstechen

Grooving and Parting Off



N

Klemmhalter

Toolholder

360

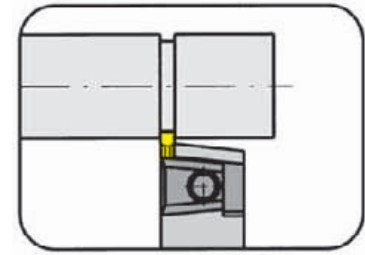

Stechtiefe bis
Spannbereich

Depth of groove up to
Clamping range

6 mm
0,5 - 2,9 mm

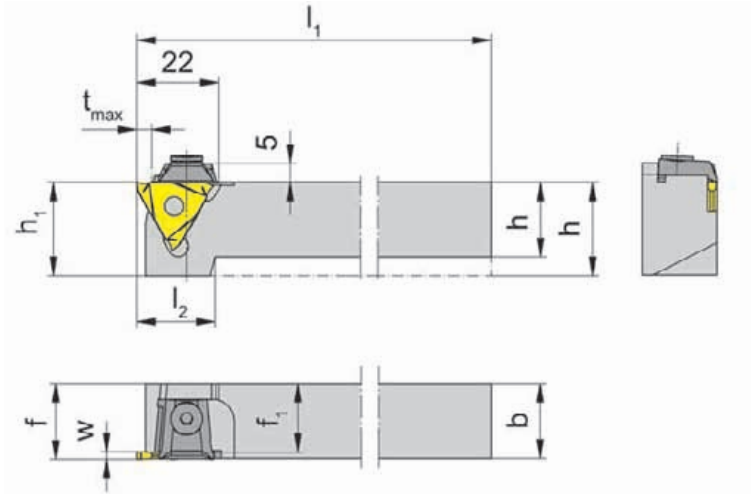

für Wendeschneidplatte
for Indexable insert

Typ 312
Type S312
N312

R = rechts wie gezeichnet
R = right hand version shown

L = links spiegelbildlich
L = left hand version

Bestellnummer Part number	h	b	l ₁	l ₂	h ₁	f	f ₁	t _{max}	Größe Size	Spannbereich Clamping range
R/L360.1212.03	12	12	100	24	25	f ₁ +w-a ₁	8,5	6	03	2,9-3,9
R/L360.1616.03	16	16	125	22	25	f ₁ +w-a ₁	12,5	6	03	2,9-3,9
R/L360.2020.03	20	20	125	21	25	f ₁ +w-a ₁	16,5	6	03	2,9-3,9
R/L360.2525.03	25	25	150	-	25	f ₁ +w-a ₁	21,5	6	03	2,9-3,9
R/L360.3232.03	32	32	170	-	32	f ₁ +w-a ₁	28,5	6	03	2,9-3,9
R/L360.1616.04	16	16	125	22	25	f ₁ +w-a ₁	10,8	6	04	3,9-6,3
R/L360.2020.04	20	20	125	21	25	f ₁ +w-a ₁	14,8	6	04	3,9-6,3
R/L360.2525.04	25	25	150	-	25	f ₁ +w-a ₁	19,8	6	04	3,9-6,3
R/L360.3232.04	32	32	170	-	32	f ₁ +w-a ₁	26,8	6	04	3,9-6,3

Ausführung R oder L angeben
State R or L version

w, a₁ siehe WSP
w, a₁ see indexable inserts

Abmessungen in mm
Dimensions in mm

Weitere Abmessungen auf Anfrage
Further sizes upon request

t_{max} nur bei Werkstück-Ø ≤ 40 mm erreichbar.
t_{max} can be reached only with workpiece Ø ≤ 40 mm

Das Anzugsdrehmoment der Schrauben finden Sie in den Technischen Hinweisen.
For torque specification of the screw, please see Technical Instructions.

Ersatzteile

Spare Parts

Klemmhalter Toolholder	Inbus-Schlüssel Wrench	Spannelement Clamping element
R/L360.1...03	SW3,0 DIN911	11.3
R/L360.1616..	SW3,0 DIN911	16.4
R/L360.1616.04	SW3,0 DIN911	13.4

Einstechen und Abstechen

Grooving and Parting Off



Klemmhalter

Toolholder

360

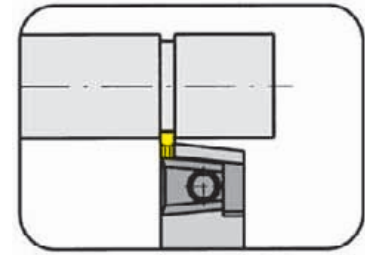

Stechtiefe bis
Spannbereich

Depth of groove up to
Clamping range

6 mm
0,5 - 2,9 mm

für Wendeschneidplatte
for Indexable insert

Typ 312
Type S312
N312

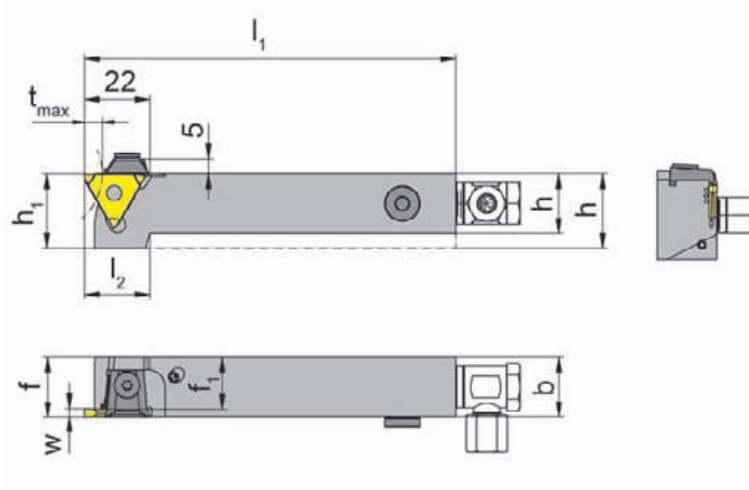

R = rechts wie gezeichnet
R = right hand version shown

L = links spiegelbildlich
L = left hand version

mit innerer
Kühlmittelzufuhr
with through coolant supply

Bestellnummer Part number	h	b	l ₁	l ₂	h ₁	f	f ₁	t _{max}	Größe Size	Spannbereich Clamping range
R/L360.1212.01.IK	12	12	100	24	25	f ₁ +w-a ₁	10,5	4	01	0,5-1,9
R/L360.1616.01.IK	16	16	125	22	25	f ₁ +w-a ₁	14,5	4	01	0,5-1,9
R/L360.2020.01.IK	20	20	125	21	25	f ₁ +w-a ₁	18,5	4	01	0,5-1,9
R/L360.2525.01.IK	25	25	150	-	25	f ₁ +w-a ₁	23,5	4	01	0,5-1,9
R/L360.1212.02.IK	12	12	100	24	25	f ₁ +w-a ₁	9,5	6	02	1,9-2,9
R/L360.1616.02.IK	16	16	125	22	25	f ₁ +w-a ₁	13,5	6	02	1,9-2,9
R/L360.2020.02.IK	20	20	125	21	25	f ₁ +w-a ₁	17,5	6	02	1,9-2,9
R/L360.2525.02.IK	25	25	150	-	25	f ₁ +w-a ₁	22,5	6	02	1,9-2,9

Ausführung R oder L angeben
State R or L version

w, a₁ siehe WSP
w, a₁ see indexable inserts

Abmessungen in mm
Dimensions in mm

t_{max} nur bei Werkstück-Ø ≤ 40 mm erreichbar.
t_{max} can be reached only with workpiece Ø ≤ 40 mm

Das Anzugsdrehmoment der Schrauben finden Sie in den Technischen Hinweisen.
For torque specification of the screw, please see Technical Instructions.

Ersatzteile

Spare Parts

Klemmhalter Toolholder	Inbus-Schlüssel Wrench	Kühlmittelanschluss Coolant supply	Spannelement Clamping element	Dichtstopfen Sealing plug
R/L360.1212.01.IK	SW2,0 DIN911	004.00.61	11.3	
R/L360.1616.01.IK	SW3,0 DIN911	004.00.16	11.3	004.00.26
R/L360....	SW3,0 DIN911	004.00.16	16.4	

Einstechen und Abstechen

Grooving and Parting Off



N

Klemmhalter

Toolholder

360

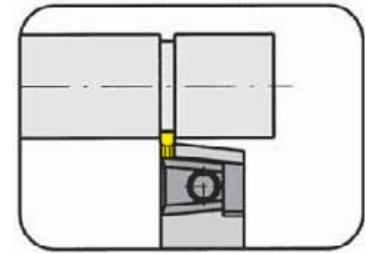

Stechtiefe bis
Spannbereich

Depth of groove up to
Clamping range

6 mm
2,9 - 3,9 mm

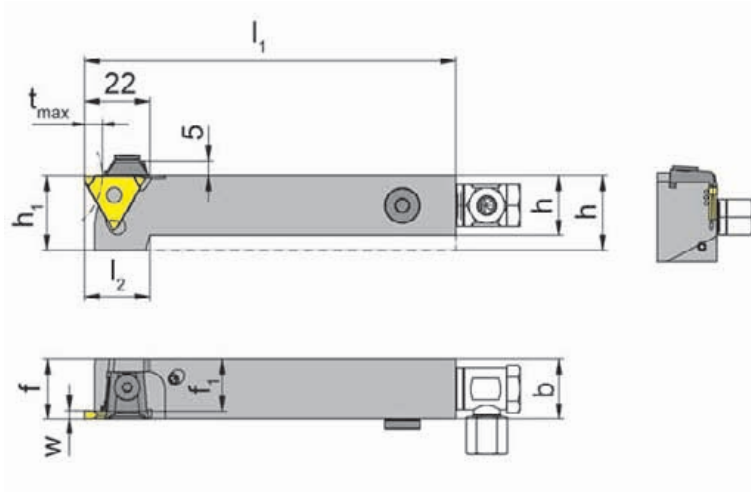

für Wendeschneidplatte
for Indexable insert

Typ 312
Type S312
N312

mit innerer
Kühlmittelzufuhr
with through coolant supply

R = rechts wie gezeichnet
R = right hand version shown

L = links spiegelbildlich
L = left hand version

Bestellnummer Part number	h	b	l ₁	l ₂	h ₁	f	f ₁	t _{max}	Größe Size	Spannbereich Clamping range
R/L360.1212.03.IK	12	12	100	24	25	f ₁ +w-a ₁	8,5	6	03	2,9-3,9
R/L360.1616.03.IK	16	16	125	22	25	f ₁ +w-a ₁	12,5	6	03	2,9-3,9
R/L360.2020.03.IK	20	20	125	21	25	f ₁ +w-a ₁	16,5	6	03	2,9-3,9
R/L360.2525.03.IK	25	25	150	-	25	f ₁ +w-a ₁	21,5	6	03	2,9-3,9

Ausführung R oder L angeben
State R or L version

w, a₁ siehe WSP
w, a₁ see indexable inserts

Abmessungen in mm
Dimensions in mm

t_{max} nur bei Werkstück-Ø ≤ 40 mm erreichbar.
t_{max} can be reached only with workpiece Ø ≤ 40 mm

Das Anzugsdrehmoment der Schrauben finden Sie in den Technischen Hinweisen.
For torque specification of the screw, please see Technical Instructions.

Ersatzteile

Spare Parts

Klemmhalter Toolholder	Inbus-Schlüssel Wrench	Kühlmittelanschluss Coolant supply	Spannelement Clamping element	Dichtstopfen Sealing plug
R/L360.1212.03.IK	SW2,0 DIN911	004.00.61	11.3	
R/L360.1616.03.IK	SW3,0 DIN911	004.00.16	11.3	004.00.26
R/L360....	SW3,0 DIN911	004.00.16	16.4	

Einstecken (außen)

Grooving (external)



Klemmhalter

Toolholder

361

verringerte Kopfgröße
reduced head size

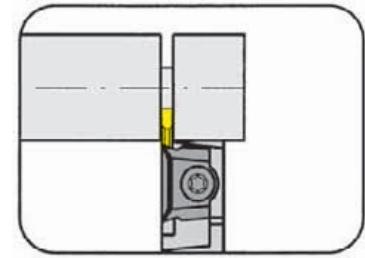

Stechtiefe bis
Spannbereich

Depth of groove up to
Clamping range

6 mm
0,5 - 3,9 mm

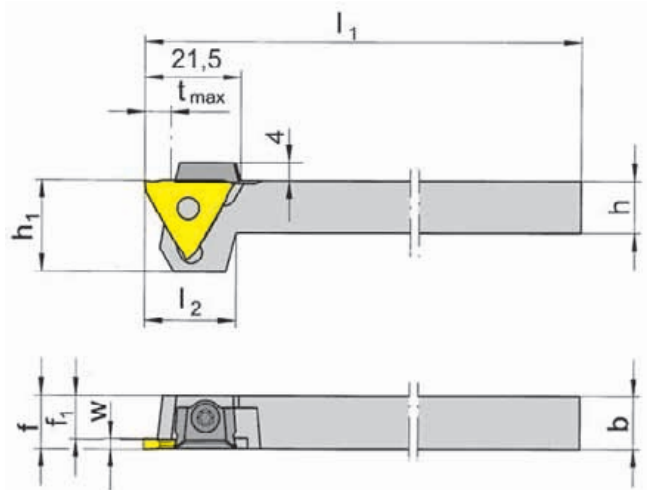

R = rechts wie gezeichnet
R = right hand version shown

L = links spiegelbildlich
L = left hand version

für Wendeschneidplatte
for Indexable insert

Typ 312
Type S312
N312

Bestellnummer Part number	h	b	l ₁	l ₂	h ₁	f ₁	f	t _{max}	Größe Size	Spannbereich Clamping range
R/L361.1212.01	12	12	100	17	19	10,5	f ₁ +w-a ₁	4	01	0,5-1,9
R/L361.1212.02	12	12	100	17	19	9,5	f ₁ +w-a ₁	6	02	1,9-2,9
R/L361.1212.03	12	12	100	21	21	8,5	f ₁ +w-a ₁	6	03	2,9-3,9

Ausführung R oder L angeben
State R or L version

w, a₁ siehe WSP
w, a₁ see indexable inserts

Abmessungen in mm
Dimensions in mm

Weitere Abmessungen auf Anfrage
Further sizes upon request

t_{max} nur bei Werkstück-Ø ≤ 40 mm erreichbar.
t_{max} can be reached only with workpiece Ø ≤ 40 mm

Das Anzugsdrehmoment der Schrauben finden Sie in den Technischen Hinweisen.
For torque specification of the screw, please see Technical Instructions.

Ersatzteile

Ersatzteile

Klemmhalter Toolholder	Spannelement Clamping element	Spannschraube Screw	TORX PLUS®-Schlüssel TORX PLUS® Wrench
R/L361...	12.3	030.0422.T10P	T10PL

Abstechen

Parting Off



N

Klemmhalter

Toolholder

368

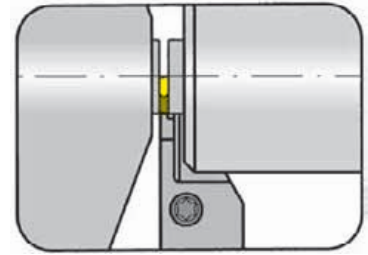

Stechtiefe bis Stechbreite	Depth of groove up to Width of groove	8 mm 0,5 - 1,5 mm
-------------------------------	--	----------------------

für TRAUB-Maschinen (TNL12/7)
for machines TRAUB (TNL12/7)

für Wendeschneidplatte
for Indexable insert

Typ 312"G"
Type

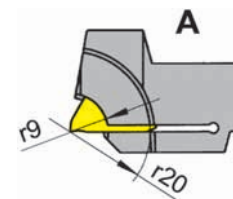
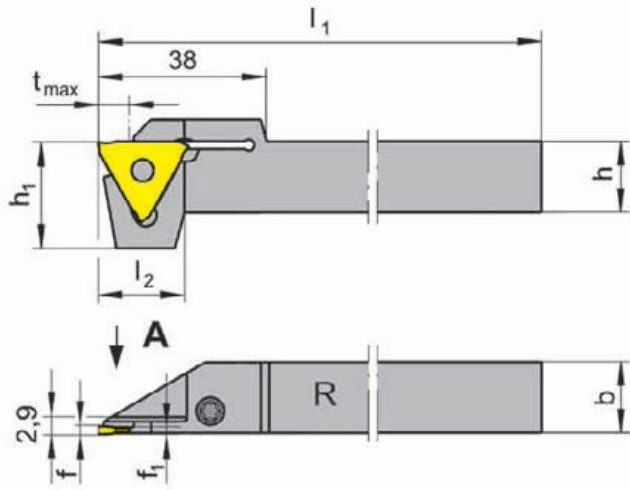

nur für umfangs-
geschliffene Form-WSP
only for periferal grounded
profiled inserts

R = rechts wie gezeichnet
R = right hand version shown

L = links spiegelbildlich
L = left hand version

Bestellnummer Part number	h	b	l ₁	l ₂	h ₁	f	f ₁	t _{max}
R/L368.1212.08	12	12	95	19,5	24	f ₁ +a ₁	1,0	8
R/L368.1616.08	16	16	95	19,5	24	f ₁ +a ₁	1,0	8
R/L368.1212.11	12	12	95	19,5	24	f ₁ +a ₁	1,3	8
R/L368.1616.11	16	16	95	19,5	24	f ₁ +a ₁	1,3	8

Ausführung R oder L angeben
State R or L version

a₁ siehe WSP
a₁ see indexable inserts

Abmessungen in mm
Dimensions in mm

Halter R/L368...08 für WSP:

R/L312.0805... / R/L312.0808... / R/L312.0510... R/L312.0512... / R/L312.1210... / R/L312.0012...

Toolholder R/L368...08 for indexable inserts:

R/L312.0805... / R/L312.0808... / R/L312.0510... R/L312.0512... / R/L312.1210... / R/L312.0012...

Halter R/L368...11 für WSP:

R/L312.0515... / R/L312.0015...

Toolholder R/L368...11 for indexable inserts:

R/L312.0515... / R/L312.0015...

Das Anzugsdrehmoment der Schrauben finden Sie in den Technischen Hinweisen.
For torque specification of the screw, please see Technical Instructions.

Ersatzteile

Spare Parts

Klemmhalter Toolholder	Spannschraube Screw	TORX PLUS®-Schlüssel TORX PLUS® Wrench
R/L368...	4.15T15P	T15PQ

Klemmhalter

Toolholder

368

mit innerer Kühlmittelzufuhr
with through coolant supply

Stechtiefe bis
Stechbreite

Depth of groove up to
Width of groove

8 mm
0,5 - 1,5 mm

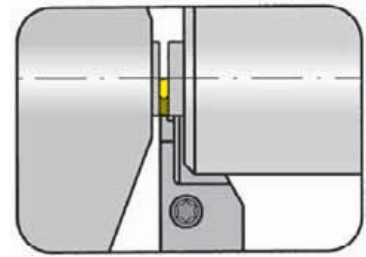

für TRAUB-Maschinen (TNL12/7)
for machines TRAUB (TNL12/7)

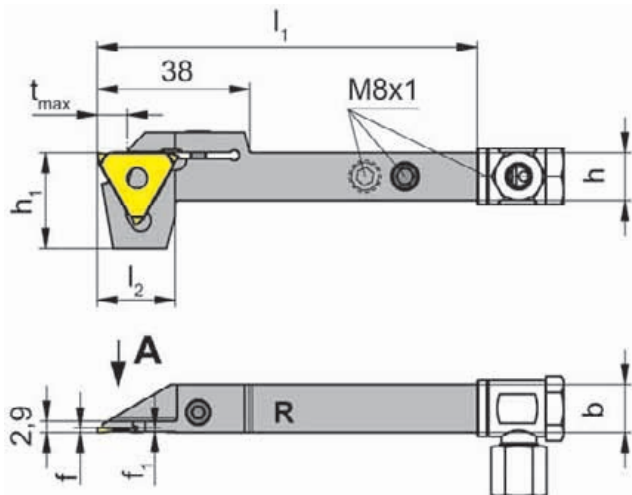

R = rechts wie gezeichnet
R = right hand version shown

L = links spiegelbildlich
L = left hand version

für Wendeschneidplatte
for Indexable insert

Typ 312"G"
Type

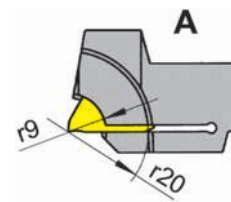

nur für umfangs-
geschliffene Form-WSP
only for periferal grounded
profiled inserts

Bestellnummer Part number	h	b	l ₁	l ₂	h ₁	f	f ₁	t _{max}
R/L368.1212.08.IK	12	12	95	19,5	24	f ₁ +a ₁	1,0	8
R/L368.1616.08.IK	16	16	95	19,5	24	f ₁ +a ₁	1,0	8
R/L368.1212.11.IK	12	12	95	19,5	24	f ₁ +a ₁	1,3	8
R/L368.1616.11.IK	16	16	95	19,5	24	f ₁ +a ₁	1,3	8

Ausführung R oder L angeben
State R or L version

a₁ siehe WSP
a₁ see indexable inserts

Abmessungen in mm
Dimensions in mm

Halter R/L368...08.IK für WSP:

R/L312.0805... / R/L312.0808... / R/L312.0510... R/L312.0512... / R/L312.1210... / R/L312.0012...

Toolholder R/L368...08.IK for indexable inserts:

R/L312.0805... / R/L312.0808... / R/L312.0510... R/L312.0512... / R/L312.1210... / R/L312.0012...

Halter R/L368...11.IK für WSP:

R/L312.0515... / R/L312.0015...

Toolholder R/L368...11.IK for indexable inserts

R/L312.0515... / R/L312.0015...

Das Anzugsdrehmoment der Schrauben finden Sie in den Technischen Hinweisen.

For torque specification of the screw, please see Technical Instructions.

Ersatzteile

Spare Parts

Klemmhalter Toolholder	Spannschraube Screw	Kühlmittelanschluss Coolant supply	TORX PLUS®-Schlüssel TORX PLUS® Wrench
R/L368.1212...	4.15T15P	004.00.61	T15PQ
R/L368.1616...	4.15T15P	004.00.16	T15PQ

Abstechen

Parting Off



N

Klemmhalter

Toolholder

368

verstärkte Ausführung
reinforced version

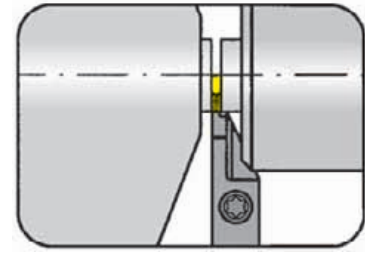

Stechtiefe bis Stechbreite	Depth of groove up to Width of groove	8 mm 0,5 - 1,5 mm
-------------------------------	--	----------------------

für Wendeschneidplatte
for Indexable insert

Typ 312"G"
Type

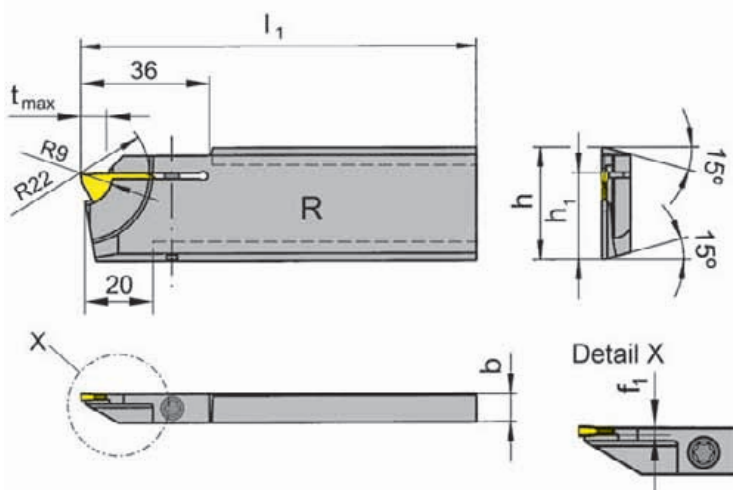

R = rechts wie gezeichnet
R = right hand version shown

L = links spiegelbildlich
L = left hand version

nur für umfangs-
geschliffene Form-WSP
only for periferal grounded
profiled inserts

Bestellnummer Part number	h	b	l ₁	h ₁	f ₁	t _{max}
R/L368.2608.08	26	8	110	21,4	1,0	8
R/L368.3208.08	32	8	110	24,8	1,0	8
R/L368.2608.11	26	8	110	21,4	1,3	8
R/L368.3208.11	32	8	110	24,8	1,3	8

Ausführung R oder L angeben
State R or L version

Abmessungen in mm
Dimensions in mm

Halter R/L368...08 für WSP:

R/L312.0805... / R/L312.0808... / R/L312.0510... R/L312.0512... / R/L312.1210... / R/L312.0012...

Toolholder R/L368...08 for indexable inserts:

R/L312.0805... / R/L312.0808... / R/L312.0510... R/L312.0512... / R/L312.1210... / R/L312.0012...

Halter R/L368...11 für WSP:

R/L312.0515... / R/L312.0015...

Toolholder R/L368...11 for indexable inserts:

R/L312.0515... / R/L312.0015...

Das Anzugsdrehmoment der Schrauben finden Sie in den Technischen Hinweisen.

For torque specification of the screw, please see Technical Instructions.

Ersatzteile

Spare Parts

Klemmhalter Toolholder	Spannschraube Screw	TORX PLUS®-Schlüssel TORX PLUS® Wrench
R/L368...	4.15T15P	T15PQ

Abstechen

Parting Off

Klemmhalter

Toolholder

368

verstärkte Ausführung
reinforced version

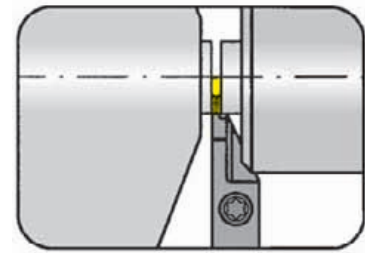

Stechtiefe bis
Stechbreite

Depth of groove up to
Width of groove

8 mm
1,1 - 2,0 mm

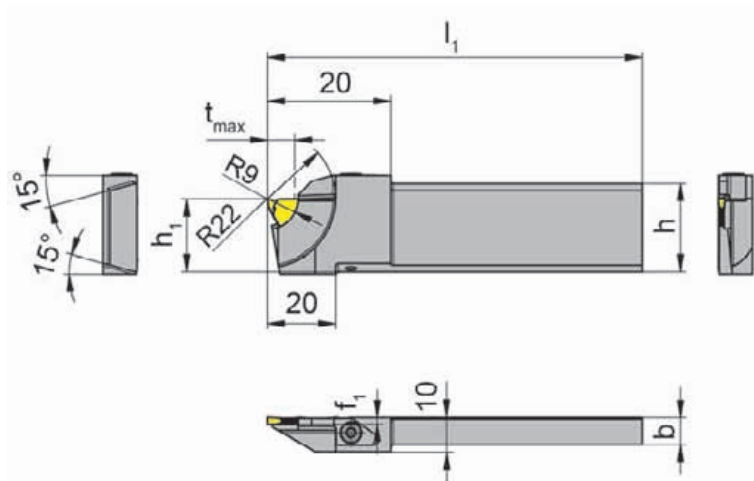

R = rechts wie gezeichnet
R = right hand version shown

L = links spiegelbildlich
L = left hand version

für Wendeschneidplatte
for Indexable insert

Typ 312
Type S312
N312

Bestellnummer Part number	h	b	l ₁	h ₁	f ₁	t _{max}
R/L368.2608.10.01	26	8	110	21,2	1	8

Ausführung R oder L angeben
State R or L version

Abmessungen in mm
Dimensions in mm

Das Anzugsdrehmoment der Schrauben finden Sie in den Technischen Hinweisen.
For torque specification of the screw, please see Technical Instructions.

Ersatzteile

Spare Parts

Klemmhalter Toolholder	Spannelement Clamping element	TORX PLUS®-Schlüssel TORX PLUS® Wrench
R/L368.2608.10.01	010.0004.0536	T10PL

Einstecken (außen)

Grooving (external)



N

Klemmhalter

Toolholder

369

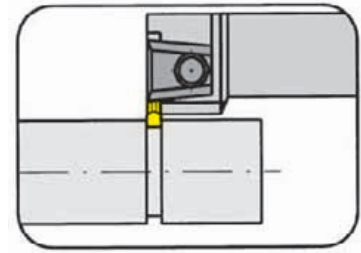

Stechtiefe bis
Spannbereich

Depth of groove up to
Clamping range

6 mm
0,5 - 6,3 mm

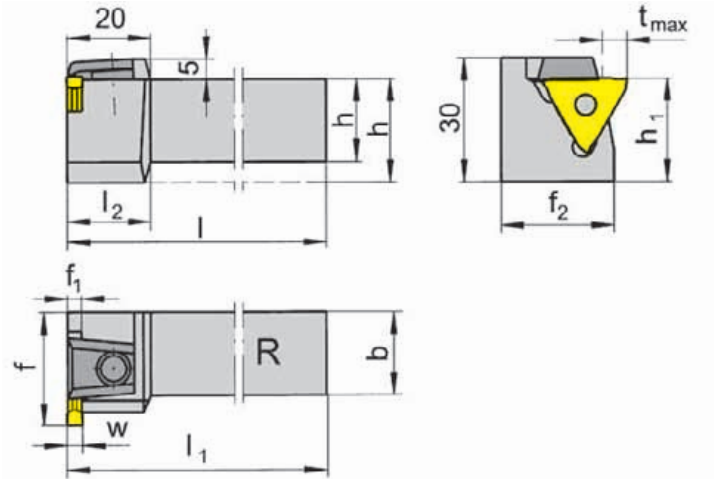

für Wendeschneidplatte
for Indexable insert

Typ 312
Type S312
N312

R = rechts wie gezeichnet
R = right hand version shown

L = links spiegelbildlich
L = left hand version

Bestellnummer Part number	h	b	l ₂	h ₁	f	t _{max}	l ₁	l	f ₁	f ₂	Größe Size	Spannbereich Clamping range
R/L369.2020.01	20	20	20	25	27	4	l-f ₁ +w-a ₁	125	1,5	23,5	01	0,5-1,9
R/L369.2525.01	25	25	-	25	32	4	l-f ₁ +w-a ₁	150	1,5	28,5	01	0,5-1,9
R/L369.2020.02	20	20	20	25	27	6	l-f ₁ +w-a ₁	125	2,5	23,5	02	1,9-2,9
R/L369.2525.02	25	25	-	25	32	6	l-f ₁ +w-a ₁	150	2,5	28,5	02	1,9-2,9
R/L369.2020.03	20	20	20	25	27	6	l-f ₁ +w-a ₁	125	3,5	23,5	03	2,9-3,9
R/L369.2525.03	25	25	-	25	32	6	l-f ₁ +w-a ₁	150	3,5	28,5	03	2,9-3,9
R/L369.2020.04	20	20	20	25	27	6	l-f ₁ +w-a ₁	125	4,5	23,5	04	3,9-6,3
R/L369.2525.04	25	25	-	25	32	6	l-f ₁ +w-a ₁	150	4,5	28,5	04	3,9-6,3

Ausführung R oder L angeben
State R or L version

w, a₁ siehe WSP
w, a₁ see indexable inserts

Abmessungen in mm
Dimensions in mm

Weitere Abmessungen auf Anfrage
Further sizes upon request

t_{max} nur bei Werkstück-Ø ≤ 40 mm erreichbar.
t_{max} can be reached only with workpiece Ø ≤ 40 mm

Das Anzugsdrehmoment der Schrauben finden Sie in den Technischen Hinweisen.
For torque specification of the screw, please see Technical Instructions.

Ersatzteile

Spare Parts

Klemmhalter Toolholder	Inbus-Schlüssel Wrench	Spannelement Clamping element
R/L369...	SW3,0 DIN911	16.4

Klemmhalter

Toolholder

369

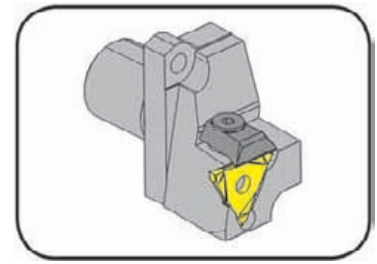

Stechtiefe
Spannbereich

Depth of groove
Clamping range

4 - 6 mm
0,5 - 2,9 mm

Lochbild 13,7 x 37,6 mm
Hole pattern 13,7 x 37,6 mm

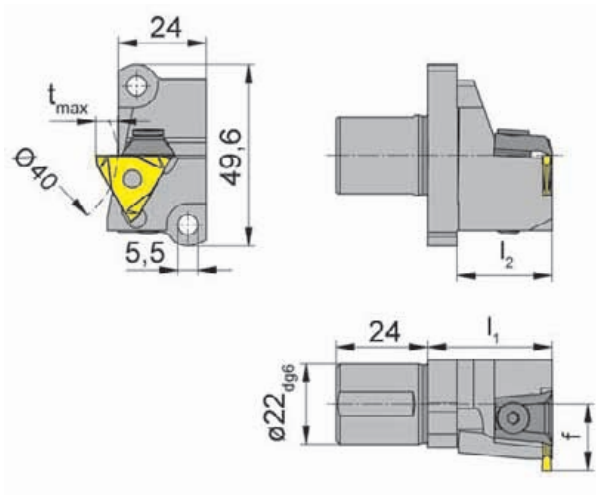

für Wendeschneidplatte
for Indexable insert

Typ 312
Type S312
N312

für Star
Langdrehautomaten
for Swiss type machines Star

L = links wie gezeichnet
L = left hand version shown

Bestellnummer Part number	l_2	f	t_{max}	l_1	Größe Size	Spannbereich Clamping range
L369.A022.18.01	26	18,2	4	34	01	0,5-1,9
L369.A022.18.02	26	18,2	6	34	02	1,9-2,9

Weitere Abmessungen auf Anfrage
Further sizes upon request

Abmessungen in mm
Dimensions in mm

Das Anzugsdrehmoment der Schrauben finden Sie in den Technischen Hinweisen.
For torque specification of the screw, please see Technical Instructions.

Star Langdrehautomaten: ECAS-12/20, SB16D/E, SR-20, SR20J/JN, RS-20RII, RS-20RIII, RS-20RIV, RS-32J/JN, SW-12RIII

Swiss Type Machines Star: ECAS-12/20, SB16D/E, SR-20, SR20J/JN, RS-20RII, RS-20RIII, RS-20RIV, RS-32J/JN, SW-12RII

Ersatzteile

Spare Parts

Klemmhalter Toolholder	Inbus-Schlüssel Wrench	Spannelement Clamping element
L369...	SW3,0 DIN911	16.4

Einstecken und Drehen

Grooving and Turning



N

Einbauhalter Graf

Cartridge Graf

64/65

mit innerer Kühlmittelzufuhr
with through coolant supply

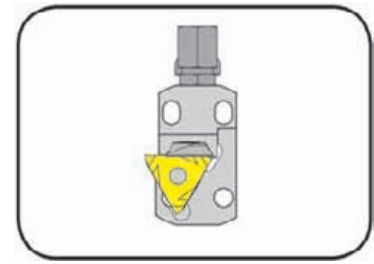

Stechtiefe
Spannbereich

Depth of groove
Clamping range

4 mm
0,5 - 2,9 mm

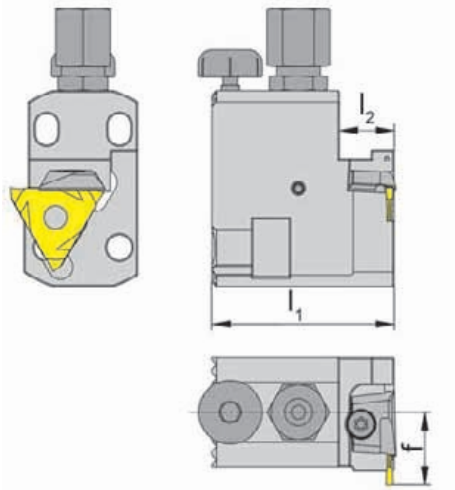

für Wendeschneidplatte
for Indexable insert

Typ 312
Type S312
N312

R = rechts wie gezeichnet
R = right hand version shown

L = links spiegelbildlich
L = left hand version

Bestellnummer Part number	l_1	l_2	f	Größe Size	Spannbereich Clamping range
R/L64IK	40	12	16	01	0,5-1,9
R/L65IK	40	12	16	02	1,9-2,9

Ausführung R oder L angeben
State R or L version

Weitere Abmessungen auf Anfrage
Further sizes upon request

Abmessungen in mm
Dimensions in mm

Ersatzteile

Spare Parts

Einbauhalter Graf Cartridge Graf	Höhenverstellungsschraube Screw to adjust the height	Kühlmittelanschluss Coolant supply	Spannelement Clamping element
L6...	002.00.69	004.00.19	4.082L
R6...	002.00.69	004.00.19	4.081R

Einbauhalter Graf

Cartridge Graf

64/65/99

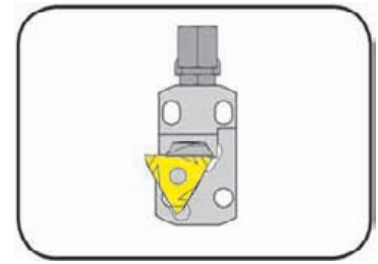
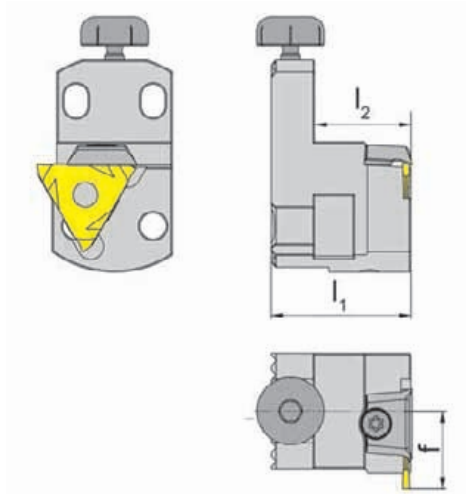
Stechtiefe
SpannbereichDepth of groove
Clamping range4,0 mm
0,5 - 3,9 mmfür Wendeschneidplatte
for Indexable insertTyp 312
Type S312
N312R = rechts wie gezeichnet
R = right hand version shownL = links spiegelbildlich
L = left hand version

Bestellnummer Part number	l_1	l_2	f	Größe Size	Spannbereich Clamping range
R/L64	29	20	16	01	0,5-1,9
R/L65	29	20	16	02	1,9-2,9
R/L99	29	20	16	03	2,9-3,9

Ausführung R oder L angeben
State R or L versionAbmessungen in mm
Dimensions in mmWeitere Abmessungen auf Anfrage
Further sizes upon request

Ersatzteile

Spare Parts

Einbauhalter Graf Cartridge Graf	Höhenverstellungsschraube Screw to adjust the height	Spannelement Clamping element
R/L...	002.00.69	4.078

Einstecken und Drehen

Grooving and Turning



N

Einstellbare Halter

Adjustable holder

N67/N68/N98

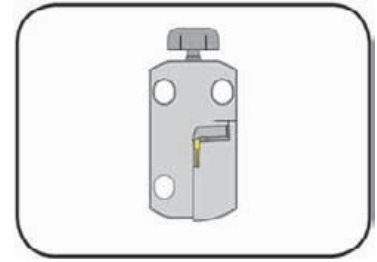

Stechtiefe Spannbereich	Depth of groove Clamping range	4,0 mm 0,5 - 3,9 mm
----------------------------	-----------------------------------	------------------------

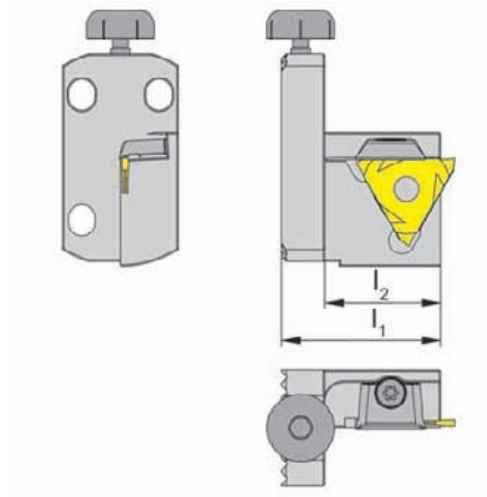

für Wendeschneidplatte
for Indexable insert

Typ 312
Type S312
N312

Bestellnummer Part number	l_1	l_2	Größe Size	Spannbereich Clamping range
N67	33	29	01	0,5-1,9
N68	33	29	02	1,9-2,9
N98	33	29	02	2,9-3,9

Weitere Abmessungen auf Anfrage
Further sizes upon request

Abmessungen in mm
Dimensions in mm

Ersatzteile

Spare Parts

Einstellbare Halter Adjustable holder	Höhenverstellungsschraube Screw to adjust the height	Spannelement Clamping element
N67	002.00.69	4.078

Einstecken (außen)

Grooving (external)



Klemmhalter

Toolholder

390

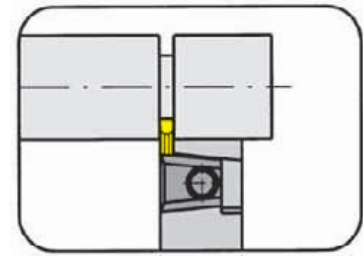

Stechtiefe bis
Spannbereich

Depth of groove up to
Clamping range

8,0 mm
1,4 - 5,3 mm

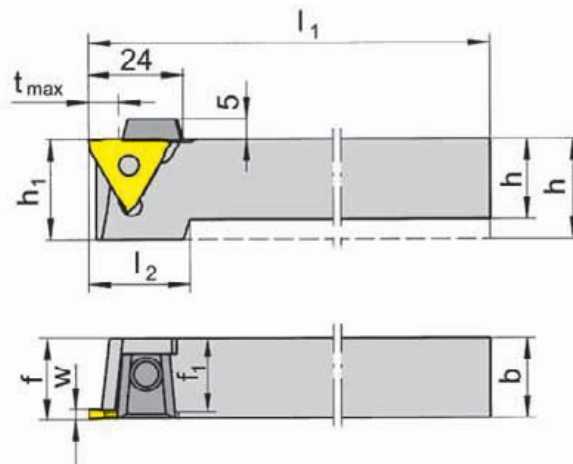

für Wendeschneidplatte
for Indexable insert

Typ 312
Type S312
N312

R = rechts wie gezeichnet
R = right hand version shown

L = links spiegelbildlich
L = left hand version

Bestellnummer Part number	h	b	l ₁	l ₂	h ₁	f	f ₁	t _{max}	Größe Size	Spannbereich Clamping range
R/L390.2020.01	20	20	125	22	25	f ₁ +w-a ₁	18,5	8	01	1,4-1,9
R/L390.2525.01	25	25	150	-	25	f ₁ +w-a ₁	23,5	8	01	1,4-1,9
R/L390.2020.02	20	20	125	22	25	f ₁ +w-a ₁	17,5	8	02	1,9-2,9
R/L390.2525.02	25	25	150	-	25	f ₁ +w-a ₁	22,5	8	02	1,9-2,9
R/L390.3232.02	32	32	170	-	32	f ₁ +w-a ₁	29,5	8	02	1,9-2,9
R/L390.2020.03	20	20	125	22	25	f ₁ +w-a ₁	16,5	8	03	2,9-3,9
R/L390.2525.03	25	25	150	-	25	f ₁ +w-a ₁	21,5	8	03	2,9-3,9
R/L390.3232.03	32	32	170	-	32	f ₁ +w-a ₁	28,5	8	03	2,9-3,9
R/L390.2020.04	20	20	125	22	25	f ₁ +w-a ₁	14,8	8	04	3,9-5,3
R/L390.2525.04	25	25	150	-	25	f ₁ +w-a ₁	19,8	8	04	3,9-5,3
R/L390.3232.04	32	32	170	-	32	f ₁ +w-a ₁	26,8	8	04	3,9-5,3

Ausführung R oder L angeben
State R or L version

w, a₁ siehe WSP
w, a₁ see indexable inserts

Abmessungen in mm
Dimensions in mm

Weitere Abmessungen auf Anfrage
Further sizes upon request

t_{max} nur bei Werkstück-Ø ≤ 125 mm erreichbar.
t_{max} can be reached only with workpiece Ø ≤ 125 mm

Das Anzugsdrehmoment der Schrauben finden Sie in den Technischen Hinweisen.
For torque specification of the screw, please see Technical Instructions.

Ersatzteile

Spare Parts

Klemmhalter Toolholder	Inbus-Schlüssel Wrench	Spannelement Clamping element
R/L390...	SW3,0 DIN911	16.4

Einstecken (außen)

Grooving (external)



N

Klemmhalter

Toolholder

391

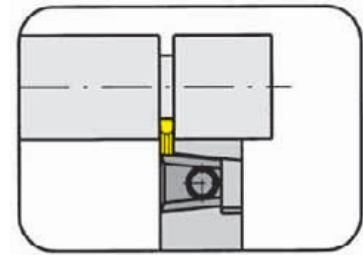

Stechtiefe bis Spannbereich	Depth of groove up to Clamping range	8,0 mm 0,5 - 1,9 mm
--------------------------------	---	------------------------

für Wendeschneidplatte
for Indexable insert

Typ 312
Type S312
N312

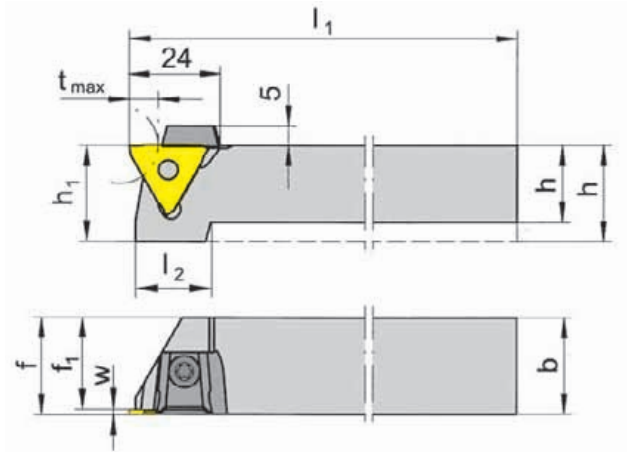

R = rechts wie gezeichnet
R = right hand version shown

L = links spiegelbildlich
L = left hand version

Bestellnummer Part number	h	b	l ₁	l ₂	h ₁	f	f ₁	t _{max}	Größe Size	Spannbereich Clamping range
R/L391.1212.01	12	12	100	21	21	f ₁ +w-a ₁	10,5	8	01	0,5-1,9
R/L391.1616.01	16	16	125	21	21	f ₁ +w-a ₁	14,5	8	01	0,5-1,9
R/L391.2020.01	20	20	125	21	21	f ₁ +w-a ₁	18,5	8	01	0,5-1,9
R/L391.2525.01	25	25	150	-	25	f ₁ +w-a ₁	23,8	8	01	0,5-1,9

Ausführung R oder L angeben
State R or L version

w, a₁ siehe WSP
w, a₁ see indexable inserts

Abmessungen in mm
Dimensions in mm

Weitere Abmessungen auf Anfrage
Further sizes upon request

t_{max} nur bei Werkstück-Ø ≤ 20 mm erreichbar.
t_{max} can be reached only with workpiece Ø ≤ 20 mm

Das Anzugsdrehmoment der Schrauben finden Sie in den Technischen Hinweisen.
For torque specification of the screw, please see Technical Instructions.

Ersatzteile

Spare Parts

Klemmhalter Toolholder	Spannelement Clamping element	TORX PLUS®-Schlüssel TORX PLUS® Wrench	Inbus-Schlüssel Wrench
R/L391.1212.01	12.3	T10PL	
R/L391.1616.01	14.4	T15PQ	
R/L391....	16.4		SW3,0 DIN911

Eckenfreistechen (außen)

Grooving Corner Reliefs (external)



Klemmhalter

Toolholder

309

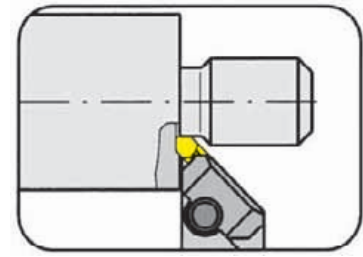

Eckenfreistechen ähnlich DIN 509 Form „F“
Corner reliefs similar to DIN 509 form „F“

für Wendeschneidplatte
for Indexable insert

Typ 312
Type S312
N312

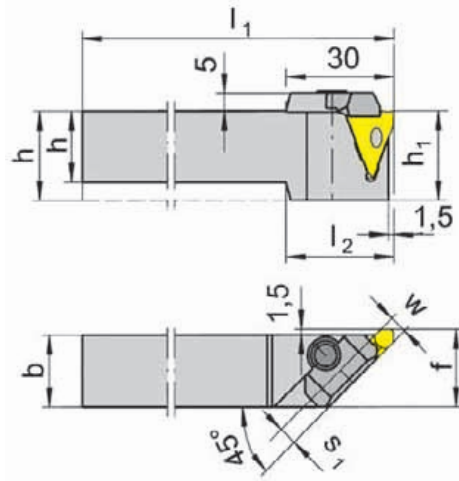

R = rechts wie gezeichnet
R = right hand version shown

L = links spiegelbildlich
L = left hand version

Bestellnummer Part number	h	b	l ₁	l ₂	h ₁	f	s ₁	Größe Size	Spannbereich Clamping range
R/L309.1616.01	16	16	125	30	25	21,5	1,5	01	0,5-1,9
R/L309.2020.02	20	20	125	30	25	21,5	2,5	02	1,9-2,9
R/L309.2525.02	25	25	150	-	25	26,5	2,5	02	1,9-2,9
R/L309.3232.02	32	32	170	-	32	33,5	2,5	02	1,9-2,9
R/L309.2020.03	20	20	125	30	25	21,5	3,5	03	2,9-3,9
R/L309.2525.03	25	25	150	-	25	26,5	3,5	03	2,9-3,9
R/L309.3232.03	32	32	170	-	32	33,5	3,5	03	2,9-3,9
R/L309.2020.04	20	20	125	30	25	21,5	5,2	04	3,9-5,3
R/L309.2525.04	25	25	150	-	25	26,5	5,2	04	3,9-5,3
R/L309.3232.04	32	32	170	-	32	33,5	5,2	04	3,9-5,3

Ausführung R oder L angeben
State R or L version

w siehe WSP
w see indexable inserts

Abmessungen in mm
Dimensions in mm

Das Anzugsdrehmoment der Schrauben finden Sie in den Technischen Hinweisen.
For torque specification of the screw, please see Technical Instructions.

Ersatzteile

Spare Parts

Klemmhalter Toolholder	Inbus-Schlüssel Wrench	Spannelement Clamping element
R/L309...	SW3,0 DIN911	21.4

Einstechen (außen)

Grooving (external)



N

Klemmhalter

Toolholder

340

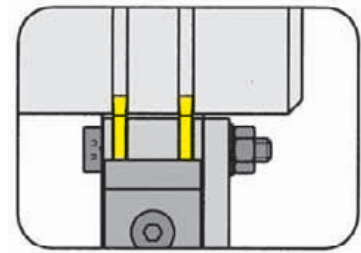

Mehrere Nuten gleichzeitig
Multi grooving

für Wendeschneidplatte
for Indexable insert

Typ 312"G"
Type

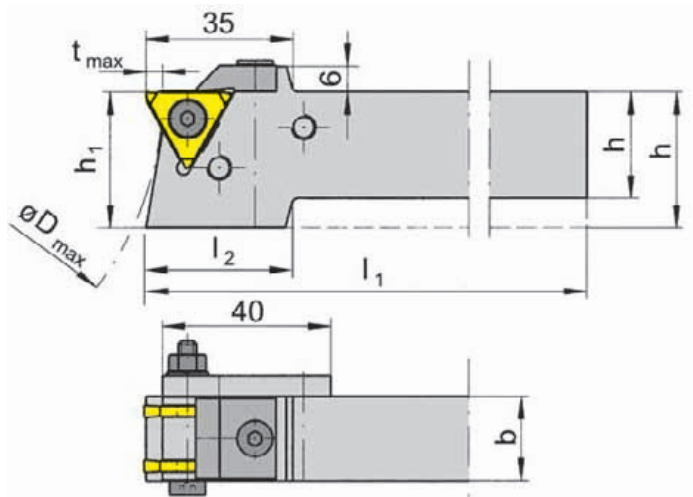

nur umfanggeschliffene WSP
verwendbar, Ausführung „G“
use only with special inserts
ground periphery type „G“

Bestellnummer Part number	h	b	l ₁	l ₂	h ₁	D _{max}	t _{max}	Größe Size
340.2020.01	20	20	170	35	32	160	4	01
340.2520.01	25	20	170	35	32	160	4	01
340.3220.01	32	20	170	-	32	160	4	01

Weitere Abmessungen auf Anfrage
Further sizes upon request

Abmessungen in mm
Dimensions in mm

Das Anzugsdrehmoment der Schrauben finden Sie in den Technischen Hinweisen.
For torque specification of the screw, please see Technical Instructions.

Rohr zur individuellen Herstellung von Distanzringen Best.Nr. 340.0012.50
Tube for producing spacing rings Part number 340.0012.50 separate order required

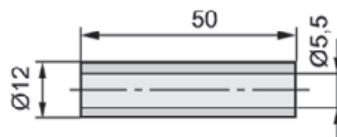

Ersatzteile

Spare Parts

Klemmhalter Toolholder	Schraube Screw	Federscheibe Spring plate	Flanschplatte Flange	Gewinding Thread-Ring	Inbus-Schlüssel Wrench	Spannelement Clamping element	Unterlegscheibe Washer
340...	5.30.7984	5.12.03	24.40	12.3.8.5	SW3,0 DIN911	340.0200	B5.3 DIN 125-St

Einstecken (außen)

Grooving (external)



Klemmhalter

Toolholder

340

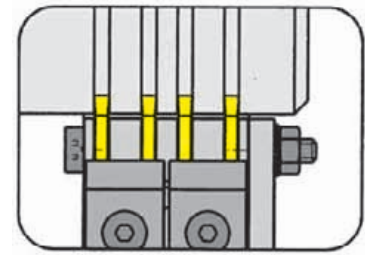

Mehrere Nuten gleichzeitig
Multi grooving

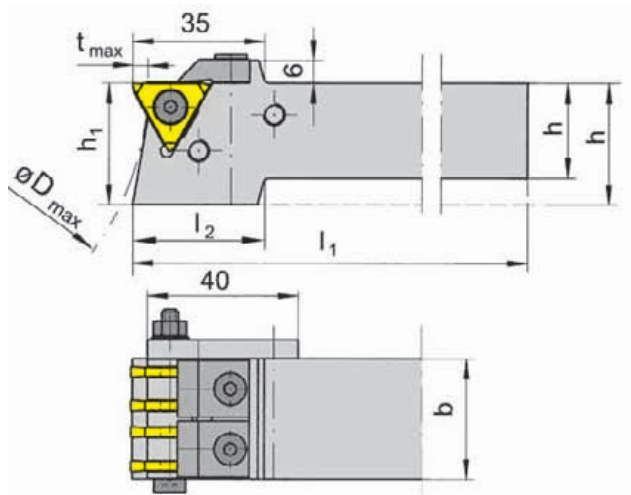

Lieferzustand **rechts** montiert
Right hand mounted

für Wendeschneidplatte
for Indexable insert

Typ 312"G"
Type

nur umfanggeschliffene WSP
verwendbar, Ausführung „G“
use only with special inserts
ground periphery type „G“

Bestellnummer Part number	h	b	l ₁	l ₂	D _{max}	h ₁	t _{max}	Größe Size
340.2532.02	25	32	170	35	160	32	4	02
340.3232.02	32	32	170	-	160	32	4	02

Weitere Abmessungen auf Anfrage
Further sizes upon request

Abmessungen in mm
Dimensions in mm

Das Anzugsdrehmoment der Schrauben finden Sie in den Technischen Hinweisen.
For torque specification of the screw, please see Technical Instructions.

Rohr zur individuellen Herstellung von Distanzringen Best.Nr. 340.0012.50
Tube for producing spacing rings Part number 340.0012.50 separate order required

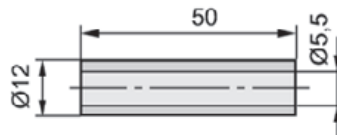

Ersatzteile

Spare Parts

Klemmhalter Toolholder	Schraube Screw	Federscheibe Spring plate	Flanschplatte Flange	Gewinde-Ring Thread-Ring	Inbus-Schlüssel Wrench	Paketschraube Package screw
340...	6.16.7991	5.12.03	24.40	12.3.8.5	SW3,0 DIN911	5.40.7984

Klemmhalter Toolholder	Spannelement Clamping element	Unterlegscheibe Washer
340...	22.16	B5.3 DIN 125-St

Einstecken (innen)

Grooving (internal)



N

Grundhalter

Basic toolholder

330

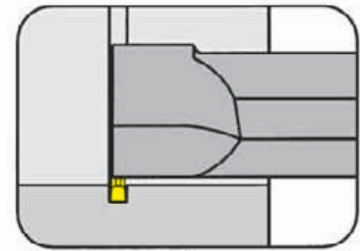

Bohrungs-Ø ab Spannbereich Bore Ø from Clamping range 46 mm
1,9 - 6,3 mm

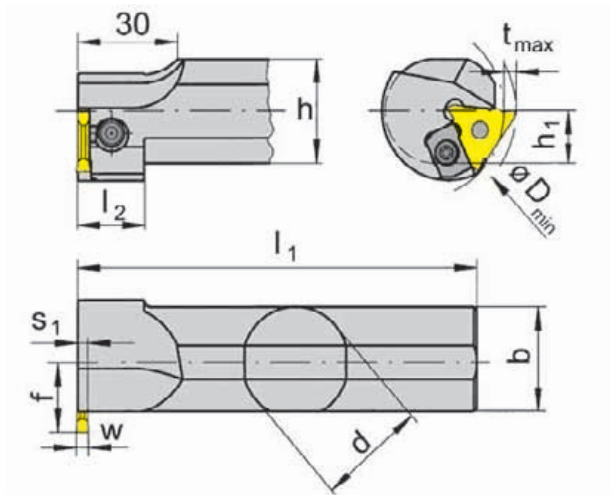

für Wendeschneidplatte
for Indexable insert

Typ 312
Type S312
N312

Stechtiefe in Abhängigkeit des Bohrungs-Ø
Depth of groove in relation to bore Ø

D _{min}	t _{max}
46	2,0
50	3,0
60	4,0
80	4,5
100	5,0

R = rechts wie gezeichnet
R = right hand version shown

L = links spiegelbildlich
L = left hand version

Bestellnummer Part number	d	l ₁	h	s ₁	h ₁	l ₂	D _{min}	b	f	Größe Size	Spannbereich Clamping range
R/L330.0025.K2	25	170	23	2,5	11,5	20	46	25	20	02	1,9-2,9
R/L330.0032.K2	32	200	30	2,5	15,0	20	46	30	20	02	1,9-2,9
R/L330.0040.K2	40	250	38	2,5	19,0	-	46	38	24	02	1,9-2,9
R/L330.0025.K3	25	170	23	3,5	11,5	20	46	25	20	03	2,9-3,9
R/L330.0032.K3	32	200	30	3,5	15,0	20	46	30	20	03	2,9-3,9
R/L330.0040.K3	40	250	38	3,5	19,0	-	46	38	24	03	2,9-3,9
R/L330.0025.K4	25	170	23	5,5	11,5	20	46	25	20	04	3,9-6,3
R/L330.0032.K4	32	200	30	5,5	15,0	20	46	30	20	04	3,9-6,3
R/L330.0040.K4	40	250	38	5,5	19,0	20	46	38	24	04	3,9-6,3

Ausführung R oder L angeben
State R or L version

w siehe WSP
w see indexable inserts

Abmessungen in mm
Dimensions in mm

Weitere Abmessungen auf Anfrage
Further sizes upon request

Das Anzugsdrehmoment der Schrauben finden Sie in den Technischen Hinweisen.
For torque specification of the screw, please see Technical Instructions.

Ersatzteile

Spare Parts

Grundhalter Basic toolholder	Anlageleiste Attachment bar	Spannschraube Screw	Inbus-Schlüssel Wrench	Spannelement Clamping element	TORX PLUS®-Schlüssel TORX PLUS® Wrench
R/L330...	020.1025.0170	5.12T20P	SW3,0 DIN911	15.4	T20PQ

Wendeschneidplatte

Indexable insert

S312

mit gesinterter Geometrie
with sintered geometries

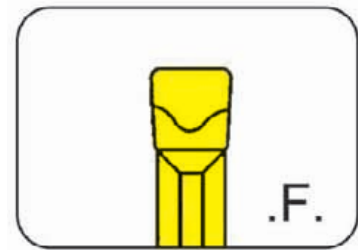

Stechbreite	Width of groove	2-5 mm
-------------	-----------------	--------

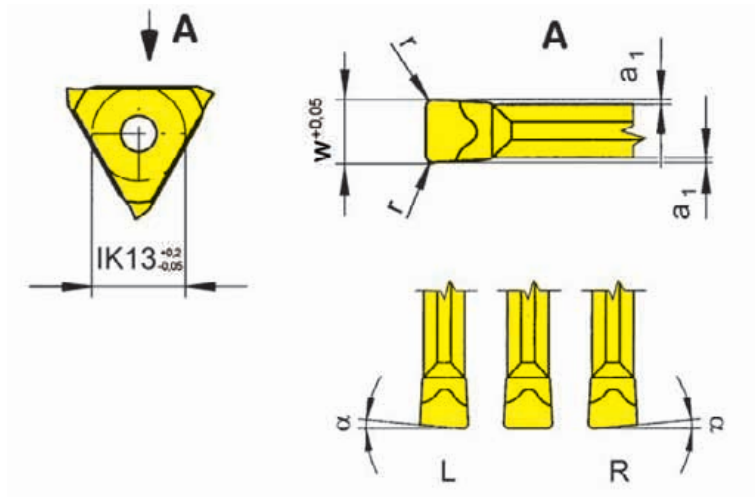

R = rechts wie gezeichnet
R = right hand version shown

L = links spiegelbildlich
L = left hand version

für Klemmhalter
for Toolholder

- Typ 309
- Type 340
- 360
- 361
- 368
- 390
- 369
- 330
- 360C
- 360TS
- N68
- 65

Geometrie .F
Geometry .F

Bestellnummer Part number	w	r	α	a ₁	Größe Size	AL96	EG56	TC92	TF45	TF46	TI25
R/LS312.0520.F2	2,0	0,2	5°	0,25	02		Δ/Δ			▲/Δ	▲/▲
S312.0200.F2	2,0	0,2	0°	0,25	02	Δ	▲	Δ	Δ	▲	▲
R/LS312.0525.F2	2,5	0,2	5°	0,25	02		▲/Δ			▲/Δ	▲/▲
S312.0250.F2	2,5	0,2	0°	0,25	02	Δ	Δ	Δ	Δ	▲	▲
S312.0400.F2	4,0	0,2	0°	0,25	04		Δ			▲	Δ
S312.0400.F4	4,0	0,4	0°	0,25	04		▲			▲	▲
S312.0500.F2	5,0	0,2	0°	0,25	04		▲			▲	
S312.0500.F4	5,0	0,4	0°	0,25	04		Δ			▲	

- ▲ ab Lager / on stock Δ 4 Wochen / 4 weeks x auf Anfrage / upon request
- empfohlen / recommended
- o bedingt einsetzbar / alternative recommendation
- nicht geeignet / not suitable
- unbeschichtete HM-Sorten / uncoated grades
- beschichtete HM-Sorten / coated grades
- bestückt/Cermet / brazed/Cermet

Abmessungen in mm
Dimensions in mm

Ausführung R oder L angeben
State R or L version

Wendeschneidplatten sind in rechten und linken Klemmhaltern verwendbar.
Indexable inserts can be used in right and left hand toolholders.

P	●	●	●	●	●	●
M	-	o	-	●	o	●
K	●	o	-	●	●	●
N	●	-	-	●	●	●
S	-	-	-	●	o	●
H	-	-	-	-	-	-

HM-Sorten
Carbide grades

Einstechen (außen und innen)

Grooving (external and internal)



N

Wendeschneidplatte

Indexable insert

S312

mit gesinterter Geometrie
with sintered geometries

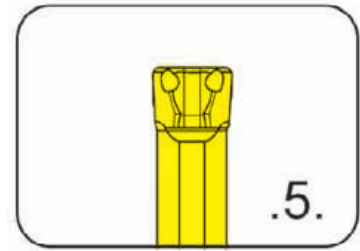

Stechbreite	Width of groove	2,5-5 mm
-------------	-----------------	----------

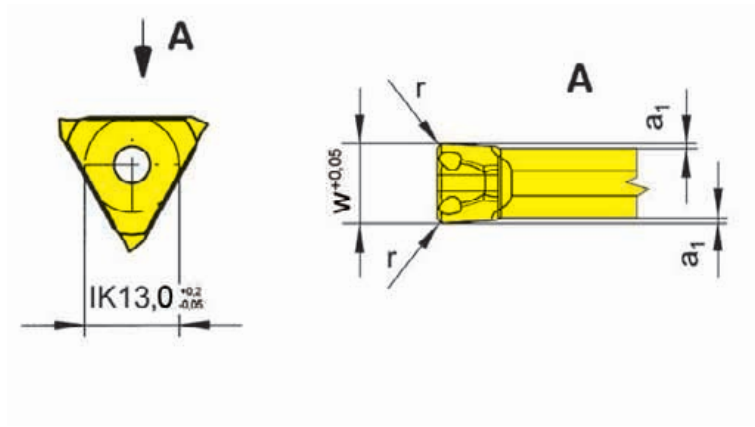

für Klemmhalter
for Toolholder

- Typ 309
Type 340
360
361
368
390
369
330
360C
360TS
N68
65

Geometrie .5
Geometry .5

Bestellnummer Part number	w	r	a ₁	Größe Size	AL96	AS62	AS66	EG56	TC92	TF45	TF46	TI25	TN32	TN35
S312.0250.52	2,5	0,2	0,25	02	▲	▲	▲	▲	△	▲	▲	▲	▲	
S312.0250.54	2,5	0,4	0,25	02	△	▲	▲	▲	△	▲	▲	▲	▲	▲
S312.0300.52	3,0	0,2	0,25	03	△	▲	▲	▲	△	▲	▲	▲	▲	
S312.0300.54	3,0	0,4	0,25	03	△	▲	▲	▲	△	△	▲	▲	▲	
S312.0400.52	4,0	0,2	0,25	04		▲	▲	▲			▲	▲	▲	△
S312.0400.54	4,0	0,4	0,25	04		▲	▲	▲			▲	▲	▲	▲
S312.0500.52	5,0	0,2	0,25	04		▲	▲	▲			▲	△	▲	
S312.0500.54	5,0	0,4	0,25	04		▲	▲	△			▲	▲	△	
▲ ab Lager / on stock △ 4 Wochen / 4 weeks x auf Anfrage / upon request					P	●	●	●	●	●	●	●	●	●
● empfohlen / recommended					M	-	-	o	o	-	o	●	-	●
o bedingt einsetzbar / alternative recommendation					K	●	-	●	o	-	●	●	-	●
- nicht geeignet / not suitable					N	●	-	●	-	-	●	●	-	●
■ unbeschichtete HM-Sorten / uncoated grades					S	-	-	o	-	-	o	●	-	●
■ beschichtete HM-Sorten / coated grades					H	-	-	-	-	-	-	-	-	-
■ bestückt/Cermet / brazed/Cermet														

Abmessungen in mm
Dimensions in mm

HM-Sorten
Carbide grades

Wendeschneidplatten sind in rechten und linken Klemmhaltern verwendbar.
Indexable inserts can be used in right and left hand toolholders.

Wendeschneidplatte

Indexable insert

S312

mit gesinterter Geometrie
with sintered geometries

Stechbreite	Width of groove	2-3 mm
-------------	-----------------	--------

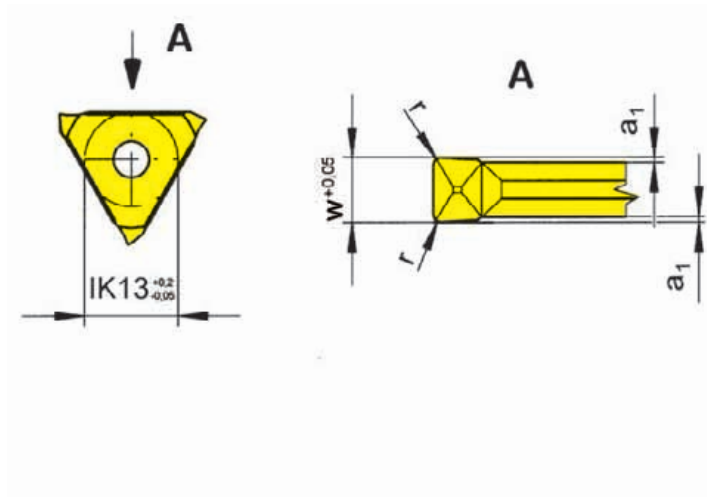
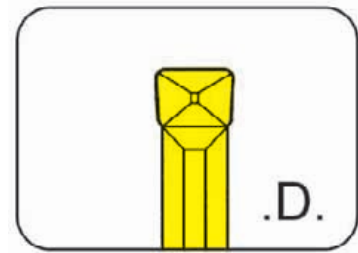

für Klemmhalter
for Toolholder

- Typ 309
- Type 340
- 360
- 361
- 368
- 390
- 369
- 330
- 360C
- 360TS
- N68
- 65

Geometrie .D
Geometry .D

Bestellnummer Part number	w	r	a ₁	Größe Size	AL96	AS62	AS66	EG56	TC92	TF45	TF46	TI25	TN32
S312.0200.D2	2,0	0,2	0,25	02	▲	▲	▲	▲	▲	▲	▲	▲	▲
S312.0200.D4	2,0	0,4	0,25	02	▲	▲	▲	▲	▲	▲	▲	▲	▲
S312.0250.D2	2,5	0,2	0,25	02	▲	▲	▲	▲	▲	▲	▲	▲	▲
S312.0250.D4	2,5	0,4	0,25	02	▲	▲	▲	▲	▲	▲	▲	▲	▲
S312.0300.D2	3,0	0,2	0,25	03	▲	▲	▲	▲	▲	▲	▲	▲	▲
S312.0300.D4	3,0	0,4	0,25	03	▲	▲	▲	▲	▲	▲	▲	▲	▲
▲ ab Lager / on stock Δ 4 Wochen / 4 weeks x auf Anfrage / upon request					P	●	●	●	●	●	●	●	●
● empfohlen / recommended					M	-	-	o	o	-	●	o	-
o bedingt einsetzbar / alternative recommendation					K	●	-	●	o	-	●	●	-
- nicht geeignet / not suitable					N	●	-	●	-	-	●	●	-
■ unbeschichtete HM-Sorten / uncoated grades					S	-	-	o	-	-	●	o	●
■ beschichtete HM-Sorten / coated grades					H	-	-	-	-	-	-	-	-
■ bestückt/Cermet / brazed/Cermet													

Abmessungen in mm
Dimensions in mm

Wendeschneidplatten sind in rechten und linken Klemmhaltern verwendbar.
Indexable inserts can be used in right and left hand toolholders.

HM-Sorten
Carbide grades

Abstechen

Parting Off



Wendeschneidplatte

Indexable insert

S312

mit gesinterter Geometrie
with sintered geometries

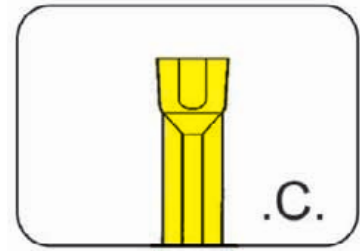

Stechtiefe bis Stechbreite	Depth of groove up to Width of groove	5 mm 2-3 mm
-------------------------------	--	----------------

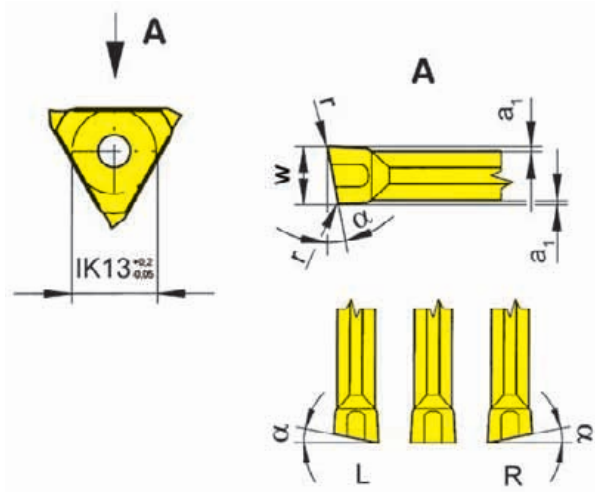

R = rechts wie gezeichnet
R = right hand version shown

L = links spiegelbildlich
L = left hand version

für Klemmhalter
for Toolholder

- Typ 309
- Type 340
- 360
- 361
- 368
- 390
- 369
- 330
- 360C
- 360TS
- N68
- 65

Geometrie .C
Geometry .C

Bestellnummer Part number	w	r	α	a_1	Größe Size	EG55	TF46	TI25
S312.0200.C2	2,0	0,2	0°	0,25	02	▲	▲	▲
R/LS312.0520.C2	2,0	0,2	5°	0,25	02	▲/▲	▲/▲	▲/▲
S312.0250.C2	2,5	0,2	0°	0,25	02	▲	▲	▲
R/LS312.0525.C2	2,5	0,2	5°	0,25	02	▲/▲	▲/▲	▲/▲
S312.0300.C2	3,0	0,2	0°	0,25	03	▲	▲	▲
R/LS312.0530.C2	3,0	0,2	5°	0,25	03	▲/▲	▲/▲	▲/▲

▲ ab Lager / on stock Δ 4 Wochen / 4 weeks x auf Anfrage / upon request

● empfohlen / recommended

o bedingt einsetzbar / alternative recommendation

- nicht geeignet / not suitable

■ unbeschichtete HM-Sorten / uncoated grades

■ beschichtete HM-Sorten / coated grades

■ bestückt/Cermet / brazed/Cermet

Abmessungen in mm

Dimensions in mm

Ausführung R oder L angeben

State R or L version

Wendeschneidplatten sind in rechten und linken Klemmhaltern verwendbar.

Indexable inserts can be used in right and left hand toolholders.

P	●	●	●
M	o	o	●
K	o	●	●
N	-	●	●
S	-	o	●
H	-	-	-

HM-Sorten
Carbide grades

Einstecken (außen)

Grooving (external)



Wendeschneidplatte

Indexable insert

312

mit runder Spanleitstufe
with round chip breaker

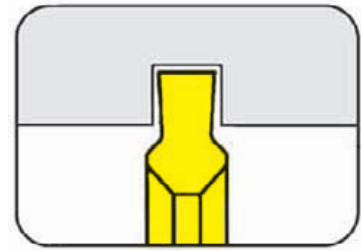

Seegerringnuten
Nutnennbreite Nw

Circlip grooves
Width of circlip Nw

DIN 471/472
0,5 - 1,0 mm

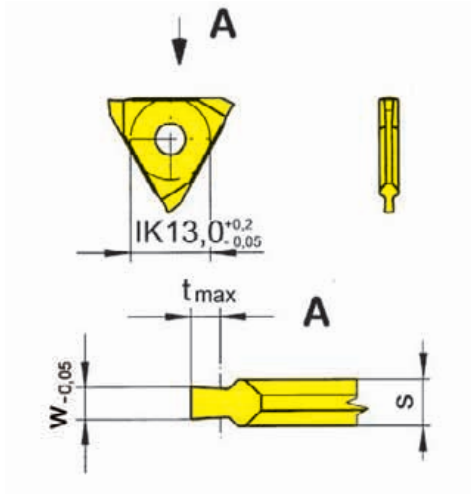

für Klemmhalter
for Toolholder

Typ 309
Type 340
360
361
368
390
369
330
360C
360TS
N68
65

Wechselgenauigkeit
Länge $\pm 0,02$ mm
Indexability length $\pm 0,02$ mm

Bestellnummer Part number	w	Nw	t _{max}	s	Größe Size	EG52	TN32
312.0050.15	0,57	0,5	0,7	1,5	01	▲	▲
312.0060.15	0,67	0,6	0,8	1,5	01	▲	▲
312.0070.15	0,77	0,7	1,1	1,5	01	▲	▲
312.0080.15	0,87	0,8	1,2	1,5	01	▲	▲
312.0090.15	0,97	0,9	1,4	1,5	01	▲	▲
312.0100.15	1,07	1,0	1,6	1,5	01	▲	▲
▲ ab Lager / on stock Δ 4 Wochen / 4 weeks x auf Anfrage / upon request						P	•
● empfohlen / recommended						M	-
o bedingt einsetzbar / alternative recommendation						K	-
- nicht geeignet / not suitable						N	-
■ unbeschichtete HM-Sorten / uncoated grades						S	-
■ beschichtete HM-Sorten / coated grades						H	•
■ bestückt/Cermet / brazed/Cermet							

Abmessungen in mm

Dimensions in mm

Wendeschneidplatten sind in rechten und linken Klemmhaltern verwendbar.

Indexable inserts can be used in right and left hand toolholders.

Weitere Abmessungen auf Anfrage

Further sizes upon request

HM-Sorten
Carbide grades

Einstechen (außen und innen)

Grooving (external and internal)



N

Wendeschneidplatte

Indexable insert

312

mit runder Spanleitstufe
with round chip breaker

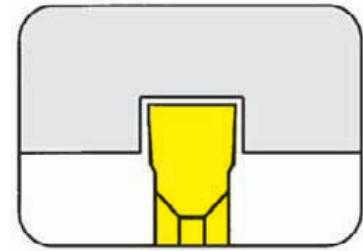

Seegerringnuten
Nutnennbreite Nw

Circlip grooves
Width of circlip Nw

DIN 471/472
0,5-1 mm

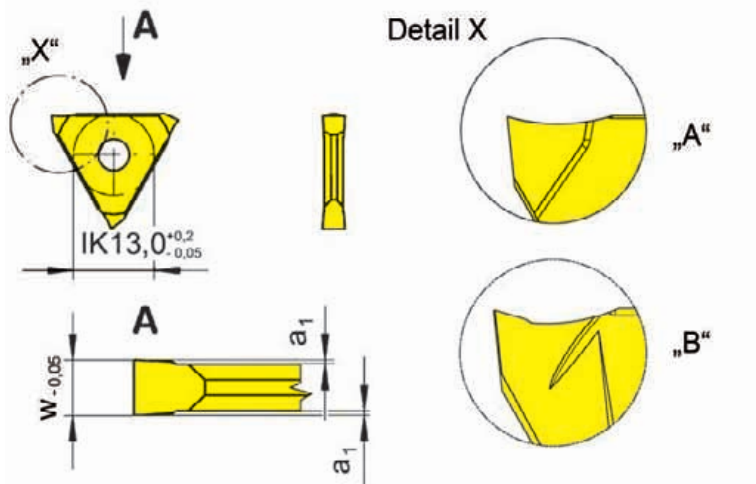

Form A = komplett geschliffen
Form A = completely ground

Form B = teilgeschliffen
Form B = partially ground

für Klemmhalter
for Toolholder

- Typ 309
- Type 340
- 360
- 361
- 368
- 390
- 369
- 330
- 360C
- 360TS
- N68
- 65

Wechselgenauigkeit
Länge ± 0,02 mm
Indexability length ± 0,02 mm

Bestellnummer Part number	w	Nw	a ₁	Form Form	Größe Size	K10	MG12	EG35	EG55	EG56	H20	HS32	HS36	P20	TA45	TC92	TF45	TF46	TI25	TN32	TN35
312.0050.00	0,57	0,50	0,07	A	01	▲			▲					▲			▲	▲		▲	
312.0060.00	0,67	0,60	0,07	A	01	▲			▲					▲			▲	▲		▲	
312.0070.00	0,77	0,70	0,08	A	01	▲			▲					▲			▲	▲		▲	
312.0080.00	0,87	0,80	0,08	A	01	▲			▲					▲			▲	▲		▲	
312.0090.00	0,97	0,90	0,08	A	01	▲			▲					▲			▲	▲		▲	▲
312.0100.00	1,07	1,00	0,09	A	01	▲			▲		Δ			▲			▲	▲		▲	▲
312.0110.00	1,24	1,10	0,20	A	01	▲			▲			Δ	Δ	▲		▲	▲	▲		▲	▲
312.0130.00	1,44	1,30	0,20	A	01	▲			▲					▲		▲	▲	▲		▲	▲
312.0160.00	1,74	1,60	0,20	A	01	▲			▲					▲		▲	▲	▲		▲	▲
312.0185.00	1,99	1,85	0,20	B	01	▲	▲		▲	Δ	▲			▲		▲	▲	▲	▲	▲	▲
312.0215.00	2,29	2,15	0,20	B	02	▲	▲		▲		▲			▲	▲	▲	▲	▲		▲	▲
312.0265.00	2,79	2,65	0,20	B	02	▲	▲		▲		▲			▲	Δ	▲	▲	▲		▲	▲
312.0315.00	3,29	3,15	0,20	B	03	▲			▲		▲			▲		▲	▲	▲		▲	▲
312.0415.00	4,29	4,15	0,20	B	04	▲			▲		▲			▲		▲	▲	▲		▲	▲
312.0515.00	5,29	5,15	0,20	B	04	▲			▲		Δ			▲		Δ	▲	▲		▲	▲

- ▲ ab Lager / on stock Δ 4 Wochen / 4 weeks
- x auf Anfrage / upon request
- empfohlen / recommended
- o bedingt einsetzbar / alternative recommendation
- nicht geeignet / not suitable
- unbeschichtete HM-Sorten / uncoated grades
- beschichtete HM-Sorten / coated grades
- bestückt/Cermet / brazed/Cermet

P	●	o	●	●	●	o	-	●	●	●	●	●	●	●	●	●	●	●	●	●	●
M	o	●	●	o	o	o	o	-	-	●	-	-	-	●	-	●	o	●	-	-	●
K	●	●	o	o	o	-	-	-	-	-	-	-	-	-	-	-	-	-	-	-	-
N	●	●	-	-	-	-	-	-	-	-	-	-	-	-	-	-	●	●	●	-	●
S	o	●	-	-	-	-	-	-	-	-	-	-	-	-	●	-	o	●	-	-	●
H	-	-	-	-	-	-	-	-	-	-	-	●	●	-	-	-	-	-	-	-	-

Abmessungen in mm
Dimensions in mm

HM-Sorten
Carbide grades

Wendeschneidplatten sind in rechten und linken Klemmhaltern verwendbar.
Indexable inserts can be used in right and left hand toolholders.

Einstecken (außen und innen)

Grooving (external and internal)



Wendeschneidplatte

Indexable insert

312

mit runder Spanleitstufe
with round chip breaker

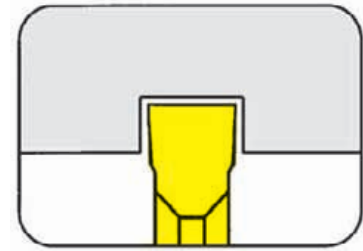

Seegerringnuten
Nutnennbreite Nw

Circlip grooves
Width of circlip Nw

DIN 471/472
1,85-5,15 mm

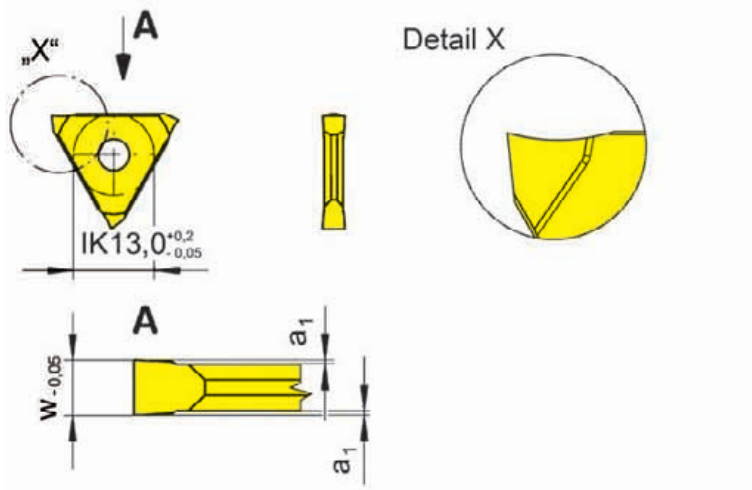

komplett geschliffen
completely ground

für Klemmhalter
for Toolholder

Typ 309
Type 340
360
361
368
390
369
330
360C
360TS
N68
65

Wechselgenauigkeit
Länge $\pm 0,02$ mm
Indexability length $\pm 0,02$ mm

Bestellnummer Part number	w	Nw	a ₁	Größe Size	K10	EG56	P20	TN32
312.0185.10	1,99	1,85	0,2	01	▲		▲	▲
312.0215.10	2,29	2,15	0,2	02	▲	▲	▲	
312.0265.10	2,79	2,65	0,2	02	▲	▲	▲	
312.0315.10	3,29	3,15	0,2	03	▲	▲	▲	
312.0415.10	4,29	4,15	0,2	04	▲	▲	▲	
312.0515.10	5,29	5,15	0,2	04	▲	▲	▲	

▲ ab Lager / on stock Δ 4 Wochen / 4 weeks x auf Anfrage / upon request

● empfohlen / recommended

o bedingt einsetzbar / alternative recommendation

- nicht geeignet / not suitable

■ unbeschichtete HM-Sorten / uncoated grades

■ beschichtete HM-Sorten / coated grades

■ bestückt/Cermet / brazed/Cermet

Abmessungen in mm

Dimensions in mm

Wendeschneidplatten sind in rechten und linken Klemmhaltern verwendbar.

Indexable inserts can be used in right and left hand toolholders.

P	●	●	●	●
M	o	o	-	-
K	●	o	-	-
N	●	-	-	-
S	o	-	-	-
H	-	-	-	-

HM-Sorten
Carbide grades

Einstecken (außen)

Grooving (external)



Wendeschneidplatte

Indexable insert

312

mit runder Spanleitstufe
with round chip breaker

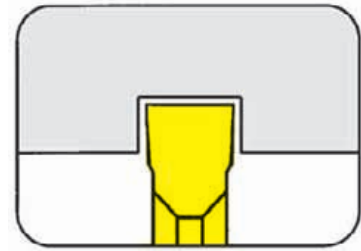

Seegerringnuten
Nutnennbreite Nw

Circlip grooves
Width of circlip Nw

DIN 471/472
1,1-5,15 mm

besonders geeignet für unterbrochenen Schnitt
recommended for interrupted cut

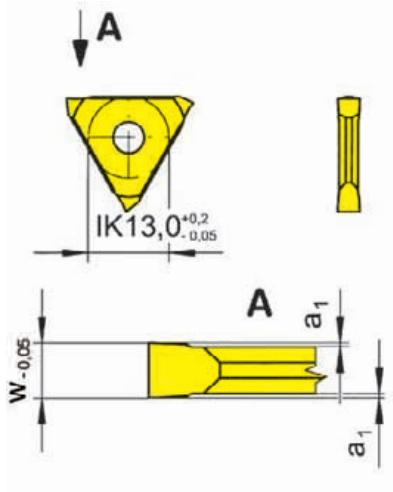

für Klemmhalter
for Toolholder

Typ 309
Type 340
360
361
368
390
369
330
360C
360TS
N68
65

Wechselgenauigkeit
Länge $\pm 0,02$ mm
Indexability length $\pm 0,02$ mm

Bestellnummer Part number	w	Nw	a ₁	Größe Size	EG55	TN35
312.0110.80	1,24	1,10	0,2	01	▲	▲
312.0130.80	1,44	1,30	0,2	01	▲	▲
312.0160.80	1,74	1,60	0,2	01	▲	▲
312.0185.80	1,99	1,85	0,2	01	▲	▲
312.0215.80	2,29	2,15	0,2	02	▲	▲
312.0265.80	2,79	2,65	0,2	02	▲	▲
312.0315.80	3,29	3,15	0,2	03	▲	▲
312.0415.80	4,29	4,15	0,2	04	▲	▲
312.0515.80	5,29	5,15	0,2	04	▲	▲
					P ● ●	
					M ○ ●	
					K ○ ●	
					N - ●	
					S - ●	
					H - -	

▲ ab Lager / on stock Δ 4 Wochen / 4 weeks x auf Anfrage / upon request

● empfohlen / recommended

○ bedingt einsetzbar / alternative recommendation

- nicht geeignet / not suitable

■ unbeschichtete HM-Sorten / uncoated grades

■ beschichtete HM-Sorten / coated grades

■ bestückt/Cermet / brazed/Cermet

Abmessungen in mm

Dimensions in mm

Wendeschneidplatten sind in rechten und linken Klemmhaltern verwendbar.

Indexable inserts can be used in right and left hand toolholders.

HM-Sorten
Carbide grades

Einstechen (außen und innen)

Grooving (external and internal)



Wendeschneidplatte

Indexable insert

312

mit runder Spanleitstufe
with round chip breaker

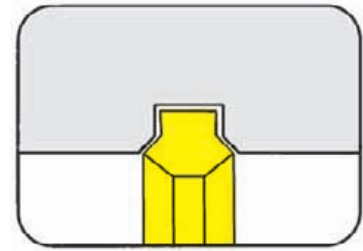

Seegerringnuten
Nutnennbreite Nw

Circlip grooves
Width of circlip Nw

DIN 471/472
1,1-5,15 mm

mit Nutaußenkantenfasung
with chamfer

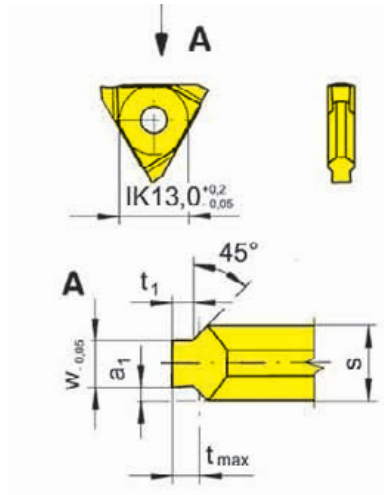

für Klemmhalter
for Toolholder

Typ 309
Type 340
360
361
368
390
369
330
360C
360TS
N68
65

Wechselgenauigkeit
Länge $\pm 0,02$ mm
Indexability length $\pm 0,02$ mm

Bestellnummer Part number	w	Nw	t _{max}	a ₁	s	t ₁	Größe Size	EG52	P20	TN32	TN35
312.1101.25	1,24	1,10	0,20	0,64	2,5	0,19	02	Δ			Δ
312.1102.25	1,24	1,10	0,25	0,64	2,5	0,24	02	▲		▲	
312.1103.25	1,24	1,10	0,30	0,64	2,5	0,29	02	▲		▲	
312.1104.25	1,24	1,10	0,35	0,64	2,5	0,33	02	Δ		▲	
312.1105.25	1,24	1,10	0,40	0,64	2,5	0,36	02	▲	▲	▲	Δ
312.1306.25	1,44	1,30	0,55	0,54	2,5	0,45	02	▲	Δ	▲	
312.1607.33	1,74	1,60	0,70	0,79	3,3	0,60	03	▲		▲	
312.1608.33	1,74	1,60	0,85	0,79	3,3	0,75	03	▲	Δ	▲	
312.1609.33	1,74	1,60	1,00	0,79	3,3	0,85	03	▲		▲	
312.1810.33	1,99	1,85	1,00	0,67	3,3	0,85	03	▲		▲	
312.1812.33	1,99	1,85	1,25	0,67	3,3	1,10	03	Δ	Δ	▲	
312.2115.43	2,29	2,15	1,50	1,02	4,3	1,35	04	Δ	▲	▲	
312.2616.43	2,79	2,65	1,50	0,77	4,3	1,35	04	Δ	▲	▲	
312.2617.43	2,79	2,65	1,75	0,77	4,3	1,60	04	Δ	Δ	▲	
312.3118.53	3,29	3,15	1,75	1,02	5,3	1,60	04	Δ	Δ	▲	
312.4120.53	4,29	4,15	2,00	0,52	5,3	1,85	04	Δ		▲	
312.4125.53	4,29	4,15	2,50	0,52	5,3	2,35	04	Δ		▲	
312.5130.63	5,29	5,15	3,00	0,52	6,3	2,85	04	Δ		▲	

▲ ab Lager / on stock Δ 4 Wochen / 4 weeks x auf Anfrage / upon request

● empfohlen / recommended

○ bedingt einsetzbar / alternative recommendation

- nicht geeignet / not suitable

■ unbeschichtete HM-Sorten / uncoated grades

■ beschichtete HM-Sorten / coated grades

■ bestückt/Cermet / brazed/Cermet

Abmessungen in mm

Dimensions in mm

Wendeschneidplatten sind in rechten und linken Klemmhaltern verwendbar.

Indexable inserts can be used in right and left hand toolholders.

N32

	P	M	K	N	S	H
●	●	●	●	●	●	●
○	○	-	-	-	○	○
-	-	-	-	-	-	-
-	-	-	-	-	-	-
-	-	-	-	-	-	-

HM-Sorten
Carbide grades

Wendeschneidplatte

Indexable insert

312

mit runder Spanleitstufe
with round chip breaker

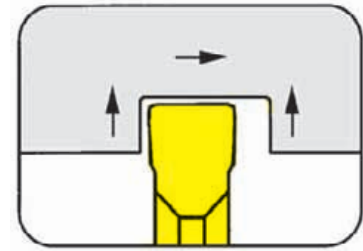

Stechtiefe bis Stechbreite	Depth of groove up to Width of groove	6 mm 1-4 mm
-------------------------------	--	----------------

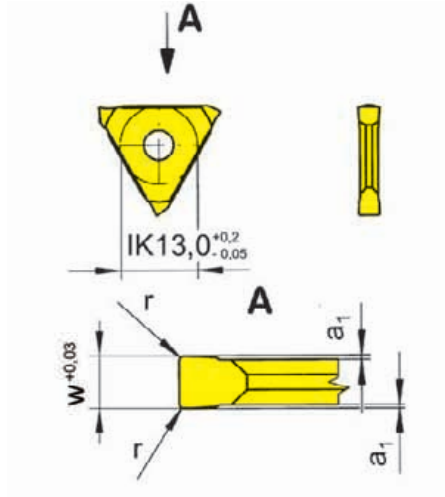

für Klemhalter
for Toolholder

- Typ 309
- Type 340
- 360
- 361
- 368
- 390
- 369
- 330
- 360C
- 360TS
- N68
- 65

Wechselgenauigkeit
Länge ± 0,02 mm
Indexability length ± 0,02 mm

Bestellnummer Part number	w	r	a ₁	Größe Size	K10	AS62	EG52	H20	P20	TF45	TI22	TI25	TN32	TN35	TN38
312.0100.02	1,0	0,2	0,10	01			Δ					▲	▲		
312.0150.02	1,5	0,2	0,25	01	Δ		Δ		▲			▲	▲	▲	
312.0200.02	2,0	0,2	0,25	02	▲		▲	▲	▲	▲	▲	▲	▲	▲	
312.0200.04	2,0	0,4	0,25	02		▲	▲	▲	▲				▲		
312.0300.02	3,0	0,2	0,25	03	Δ		▲	▲	▲			▲	▲		
312.0300.06	3,0	0,6	0,25	03			▲		▲				▲		
312.0300.08	3,0	0,8	0,25	03			▲		Δ				▲		Δ
312.0400.02	4,0	0,2	0,25	04			▲	▲	▲				▲		
312.0400.08	4,0	0,8	0,25	04			▲		Δ				▲		
312.0400.12	4,0	1,2	0,25	04			Δ		Δ						
▲ ab Lager / on stock Δ 4 Wochen / 4 weeks x auf Anfrage / upon request					P	•	•	•	•	•	•	•	•	•	•
● empfohlen / recommended					M	o	-	o	o	-	•	-	•	-	•
o bedingt einsetzbar / alternative recommendation					K	•	-	o	-	-	•	-	•	-	-
- nicht geeignet / not suitable					N	•	-	-	-	•	-	•	-	•	-
unbeschichtete HM-Sorten / uncoated grades					S	o	-	-	-	•	-	•	-	•	-
beschichtete HM-Sorten / coated grades					H	-	-	-	-	-	-	-	-	-	-
bestückt/Cermet / brazed/Cermet															

Abmessungen in mm
Dimensions in mm

Wendeschneidplatten sind in rechten und linken Klemmaltern verwendbar.
Indexable inserts can be used in right and left hand toolholders.

HM-Sorten
Carbide grades

Einstechen und Längsdrehen

Grooving and Side Turning



Wendeschneidplatte

Indexable insert

312

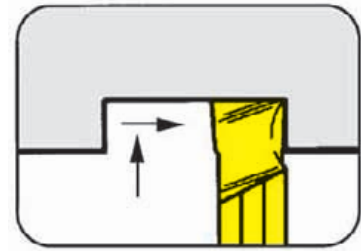

Schnitttiefe bis Depth of cut up to 3,5 mm

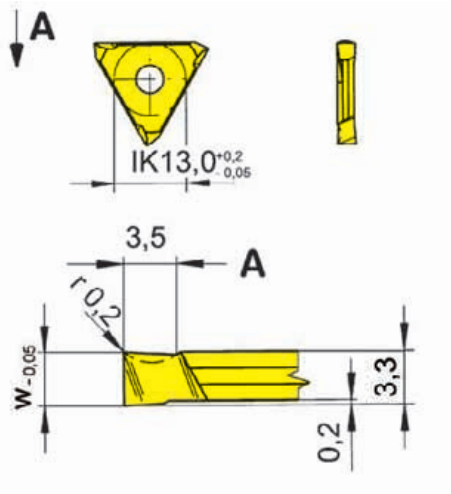

L = links wie gezeichnet
L = left hand version shown

R = rechts spiegelbildlich
R = right hand version

für Klemhalter
for Toolholder

Typ 309
Type 340
 360
 361
 368
 390
 369
 330
 360C
 360TS
 N68
 65

Wechselgenauigkeit
Länge $\pm 0,02$ mm
Indexability length $\pm 0,02$ mm

Bestellnummer Part number	w	Größe Size	HM-Sorten Carbide grades			
			EG52	P20	TC92	TN32
R/L312.3031.33	3,29	03	▲/▲	▲/▲	▲/▲	▲/▲
▲ ab Lager / on stock Δ 4 Wochen / 4 weeks x auf Anfrage / upon request			P	•	•	•
● empfohlen / recommended			M	○	-	-
○ bedingt einsetzbar / alternative recommendation			K	○	-	-
- nicht geeignet / not suitable			N	-	-	-
■ unbeschichtete HM-Sorten / uncoated grades			S	-	-	-
■ beschichtete HM-Sorten / coated grades			H	-	-	-
■ bestückt/Cermet / brazed/Cermet						

Abmessungen in mm
Dimensions in mm

Ausführung R oder L angeben
State R or L version

Wendeschneidplatten sind in rechten und linken Klemhaltern verwendbar.
Indexable inserts can be used in right and left hand toolholders.

Die besondere Schneidengeometrie erlaubt unter Beibehaltung einer geraden und rechtwinkligen Hauptschneide sowohl in radialer als auch in axialer Richtung positive Spanwinkel.

The special cutting geometry permits a positive chip breaking angle when keeping a straight and right angled cutting edge.

Eckenfreistechen (außen)

Grooving Corner Reliefs (external)



Wendeschneidplatte

Indexable insert

312

mit runder Spanleitstufe
with round chip breaker

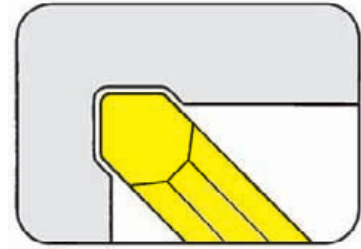

Eckenfreistriche ähnlich DIN 509 Form „F“
Corner reliefs similar to DIN 509 form „F“

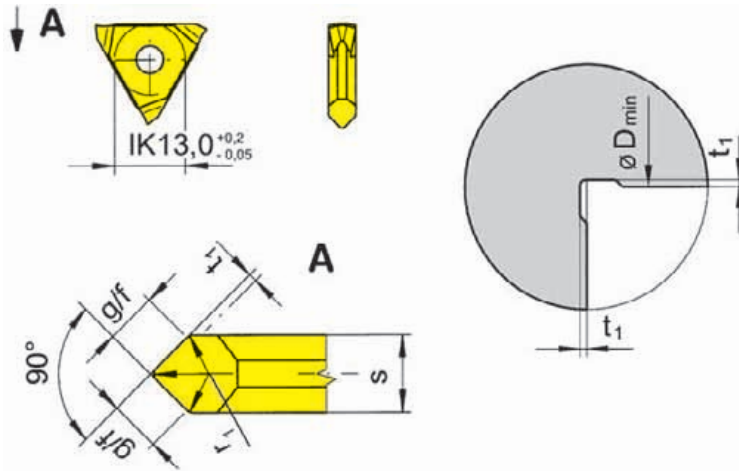

für Klemmhalter
for Toolholder

- Typ 309
- Type 340
- 360
- 361
- 368
- 390
- 369
- 330
- 360C
- 360TS
- N68
- 65

Wechselgenauigkeit
Länge ± 0,02 mm
Indexability length ± 0,02 mm

Bestellnummer Part number	D _{min}	t ₁	s	gf	r ₁	Größe Size	AS62	EG52	P20	TC92	
312.0602.24	19	0,2	2,4	1,7	0,6	02	▲	▲	▲	▲	
312.0603.33	23	0,3	3,3	2,3	0,6	03		▲	▲		
312.1002.30	20	0,2	3,0	2,1	1,0	03		△	▲		
312.1004.50	29	0,4	5,0	3,6	1,0	04		▲	▲		
312.1603.50	25	0,3	5,0	3,6	1,6	04		△	▲		
							P	●	●	●	●
							M	-	○	-	-
							K	-	-	-	-
							N	-	-	-	-
							S	-	-	-	-
							H	-	-	-	-

- ▲ ab Lager / on stock △ 4 Wochen / 4 weeks x auf Anfrage / upon request
- empfohlen / recommended
- bedingt einsetzbar / alternative recommendation
- nicht geeignet / not suitable
- unbeschichtete HM-Sorten / uncoated grades
- beschichtete HM-Sorten / coated grades
- bestückt/Cermet / brazed/Cermet

Abmessungen in mm
Dimensions in mm

Wendeschneidplatten sind in rechten und linken Klemmhaltern verwendbar.
Indexable inserts can be used in right and left hand toolholders.

HM-Sorten
Carbide grades

Eckenfreistechen (außen)

Grooving Corner Reliefs (external)



Wendeschneidplatte

Indexable insert

312

mit runder Spanleitstufe
with round chip breaker

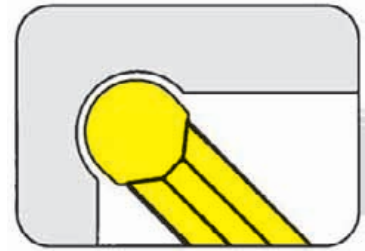

Vollradius	Full radius	1-2,5 mm
------------	-------------	----------

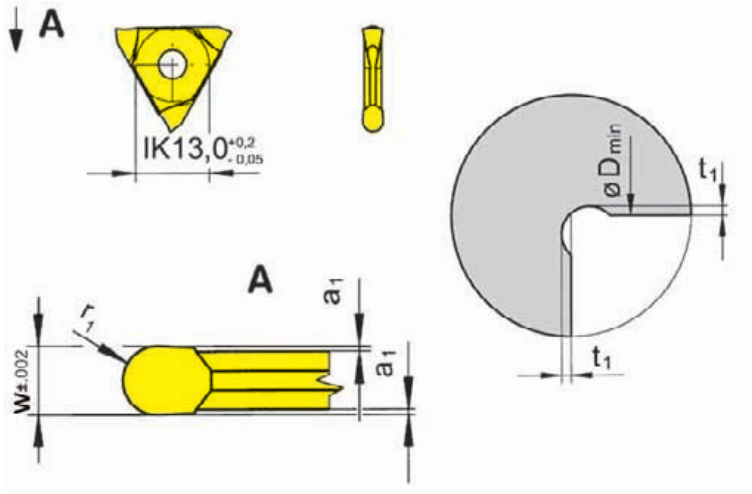

für Klemmhalter
for Toolholder

- Typ 309
- Type 340
- 360
- 361
- 368
- 390
- 369
- 330
- 360C
- 360TS
- N68
- 65

Wechselgenauigkeit
Länge ± 0,02 mm
Indexability length ± 0,02 mm

Bestellnummer Part number	w	a ₁	r ₁	D _{min}	t ₁	Größe Size	Material							
							K10	EG52	P20	TC92	TF45	TN32	TN35	
312.0010.20	2	0,2	1,0	22	0,7	02	▲	▲	▲	▲	▲	▲	▲	
312.0015.30	3	0,2	1,5	27	1,0	03	▲	▲	▲	▲	▲	▲	▲	
312.0020.40	4	0,2	2,0	30	1,2	04	▲	▲	▲	▲	▲	▲	▲	
312.0025.50	5	0,2	2,5	35	1,5	04	▲	▲	▲	▲	▲	▲	▲	
▲ ab Lager / on stock Δ 4 Wochen / 4 weeks x auf Anfrage / upon request ● empfohlen / recommended ○ bedingt einsetzbar / alternative recommendation - nicht geeignet / not suitable □ unbeschichtete HM-Sorten / uncoated grades ■ beschichtete HM-Sorten / coated grades ■ bestückt/Cermet / brazed/Cermet							P	●	●	●	●	●	●	●
							M	○	○	-	-	●	-	●
							K	●	○	-	-	●	-	●
							N	●	-	-	-	●	-	●
							S	○	-	-	-	●	-	●
							H	-	-	-	-	-	-	-

HM-Sorten
Carbide grades

Abmessungen in mm
Dimensions in mm

Wendeschneidplatten sind in rechten und linken Klemmhaltern verwendbar.
Indexable inserts can be used in right and left hand toolholders.

Einstecken/Profildrehen (Vollradius)

Grooving and Profiling (Full radius)



N

Wendeschneidplatte

Indexable insert

312

mit runder Spanleitstufe
with round chip breaker

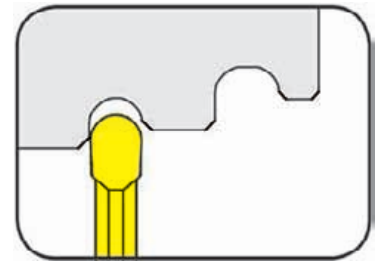

Stechtiefe bis Vollradius	Depth of groove up to Full radius	6,0 mm 0,25 - 2,0 mm
---------------------------	-----------------------------------	-------------------------

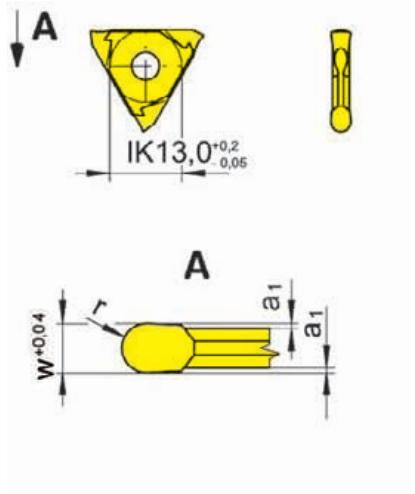

für Klemmhalter
for Toolholder

- Typ 309
Type 340
360
361
368
390
369
330
360C
360TS
N68
65

Wechselgenauigkeit
Länge ± 0,02 mm
Indexability length ± 0,02 mm

Bestellnummer Part number	w	a ₁	r	Größe Size	AS45	EG35	EG55	P20	TF45	TH35	TI25	TN32	TN35
312.0050.02	0,5	0,07	0,25	01	▲	▲		▲				▲	
312.0100.05	1,0	0,09	0,50	01	▲	▲		▲		Δ		▲	Δ
312.0110.05	1,1	0,09	0,55	01	▲		Δ						
312.0120.06	1,2	0,20	0,60	01	▲		▲	▲				▲	
312.0140.07	1,4	0,20	0,70	01	▲		▲	▲					
312.0160.08	1,6	0,25	0,80	01	▲		▲	▲				▲	
312.0180.09	1,8	0,25	0,90	01	▲		▲	▲					
312.0200.10	2,0	0,25	1,00	01	▲		▲	▲	Δ		Δ	▲	
312.0220.11	2,2	0,25	1,10	02	▲		▲	▲					
312.0250.12	2,5	0,25	1,25	02	▲		Δ	▲				▲	
312.0280.14	2,8	0,25	1,40	02	▲		Δ	▲					
312.0300.15	3,0	0,25	1,50	02	▲		▲	▲				▲	
312.0360.18	3,6	0,25	1,80	03	▲		Δ						
312.0400.20	4,0	0,25	2,00	03	▲		Δ	▲				▲	
312.0400.20	4,0	0,25	2,00	03	▲		Δ	▲				▲	

- ▲ ab Lager / on stock Δ 4 Wochen / 4 weeks x auf Anfrage / upon request
- empfohlen / recommended
- o bedingt einsetzbar / alternative recommendation
- nicht geeignet / not suitable
- unbeschichtete HM-Sorten / uncoated grades
- beschichtete HM-Sorten / coated grades
- bestückt/Cermet / brazed/Cermet

P	●	●	●	●	●	●	●	●	●	●	●	●	●
M	●	●	o	-	●	●	●	●	●	●	●	-	●
K	●	o	o	-	●	●	●	●	●	●	●	-	●
N	o	-	-	-	●	●	●	●	●	●	●	-	●
S	●	-	-	-	●	●	●	●	●	●	●	-	●
H	-	-	-	-	-	-	-	-	-	-	-	-	-

Weitere Radien auf Anfrage
Further radii upon request

Abmessungen in mm
Dimensions in mm

HM-Sorten
Carbide grades

Bearbeitungshinweis:

Nutbreiten bis 1,6 mm nur zum Nutzenstechdrehen empfohlen

Note:

Width of groove up to 1,6 mm recommend only for grooving

Wendeschneidplatten sind in rechten und linken Klemmhaltern verwendbar.

Indexable inserts can be used in right and left hand toolholders.

Einstechen (außen)

Grooving (external)



Wendeschneidplatte

Indexable insert

312

mit runder Spanleitstufe
with round chip breaker

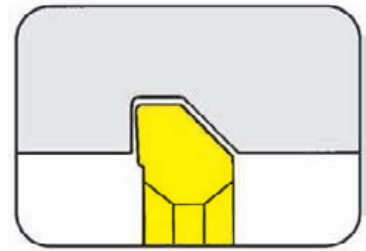

Gewindfreistriche DIN 76 „Kurzausführung“
Thread relief DIN 76 „Short form“

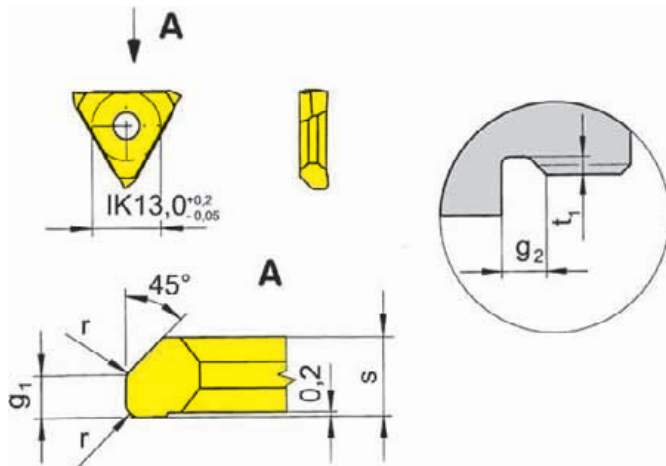

R = rechts wie gezeichnet
R = right hand version shown

L = links spiegelbildlich
L = left hand version

für Klemmhalter
for Toolholder

Typ 309
Type 340
360
361
368
390
369
330
360C
360TS
N68
65

Wechselgenauigkeit
Länge $\pm 0,02$ mm
Indexability length $\pm 0,02$ mm

Bestellnummer Part number	P	r	t ₁	s	g ₁	g ₂	Größe Size	EG55	P20	TN35
R/L312.1050.17	0,50	0,2	0,40	1,7	0,60	1,0	01	▲/▲	▲/▲	▲/▲
R/L312.1060.17	0,60	0,4	0,50	1,7	0,70	1,2	01	▲/▲	▲/▲	▲/▲
R/L312.1070.17	0,70	0,4	0,55	1,7	0,85	1,4	01	▲/▲	▲/▲	▲/▲
R/L312.1080.27	0,80	0,4	0,65	2,7	0,95	1,6	02	▲/▲	▲/▲	▲/▲
R/L312.1100.27	1,00	0,6	0,80	2,7	1,20	2,0	02	▲/▲	▲/▲	▲/▲
R/L312.1125.27	1,25	0,6	1,00	2,7	1,50	2,5	02	▲/▲	▲/▲	▲/▲
R/L312.1150.37	1,50	0,8	1,15	3,7	1,85	3,0	03	▲/▲	▲/▲	▲/▲
R/L312.1175.37	1,75	1,0	1,30	3,7	2,20	3,5	03	▲/▲	▲/▲	▲/▲
R/L312.1200.53	2,00	1,0	1,50	5,3	2,50	4,0	04	▲/▲	▲/▲	▲/▲
R/L312.1250.53	2,50	1,2	1,80	5,3	3,20	5,0	04	▲/▲	▲/▲	▲/▲
R/L312.1300.63	3,00	1,6	2,20	6,3	3,80	6,0	04	▲/▲	▲/▲	▲/▲

▲ ab Lager / on stock Δ 4 Wochen / 4 weeks x auf Anfrage / upon request

● empfohlen / recommended

o bedingt einsetzbar / alternative recommendation

- nicht geeignet / not suitable

■ unbeschichtete HM-Sorten / uncoated grades

■ beschichtete HM-Sorten / coated grades

■ bestückt/Cermet / brazed/Cermet

Abmessungen in mm

Dimensions in mm

Ausführung R oder L angeben

State R or L version

Rechte WSP in rechten, linke WSP in linken Klemmhaltern verwenden.

Use right hand inserts in right hand toolholders and left hand inserts in left hand toolholders

P	●	●	●
M	○	-	●
K	○	-	●
N	-	-	●
S	-	-	●
H	-	-	-

HM-Sorten
Carbide grades

Einstechen (außen)

Grooving (external)



Wendeschneidplatte

Indexable insert

312

mit runder Spanleitstufe
with round chip breaker

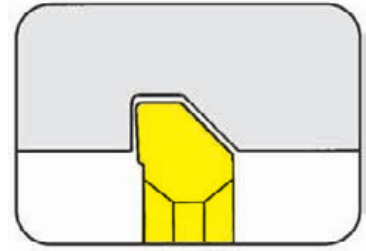

Gewindereifstiche DIN 76 „Regelausführung“
Thread relief DIN 76 „Standard form“

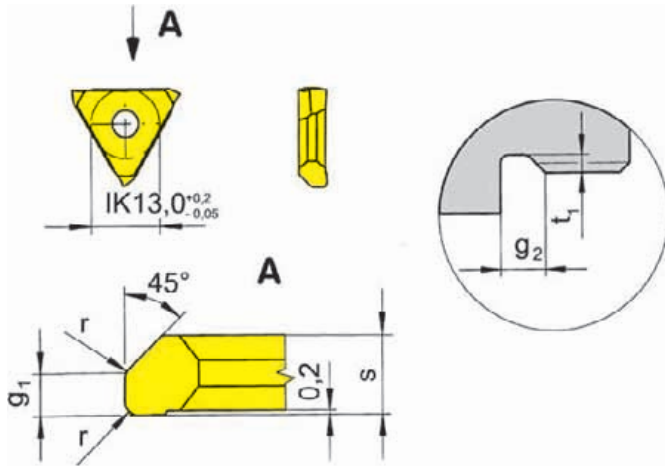

für Klemmhalter
for Toolholder

- Typ 309
- Type 340
- 360
- 361
- 368
- 390
- 369
- 330
- 360C
- 360TS
- N68
- 65

Wechselgenauigkeit
Länge ± 0,02 mm
Indexability length ± 0,02 mm

R = rechts wie gezeichnet
R = right hand version shown

L = links spiegelbildlich
L = left hand version

Bestellnummer Part number	P	r	t ₁	s	g ₁	g ₂	Größe Size	EG55	P20	TN35
R/L312.3050.17	0,50	0,2	0,40	1,7	1,10	1,5	01	Δ/Δ	x/Δ	Δ/▲
R/L312.3060.27	0,60	0,4	0,50	2,7	1,30	1,8	02	▲/▲	Δ/Δ	▲/Δ
R/L312.3070.27	0,70	0,4	0,55	2,7	1,55	2,1	02	Δ/Δ	Δ/Δ	Δ/Δ
R/L312.3080.27	0,80	0,4	0,65	2,7	1,75	2,4	02	Δ/Δ	Δ/Δ	Δ/Δ
R/L312.3100.37	1,00	0,6	0,80	3,7	2,20	3,0	03	▲/Δ	Δ/Δ	▲/Δ
R/L312.3125.53	1,25	0,6	1,00	5,3	2,80	3,8	04	Δ/Δ	Δ/Δ	Δ/Δ
R/L312.3150.53	1,50	0,8	1,15	5,3	3,35	4,5	04	▲/Δ	Δ/Δ	▲/Δ
R/L312.3175.56	1,75	1,0	1,30	5,6	4,00	5,3	04	Δ/Δ	Δ/Δ	Δ/Δ
R/L312.3200.63	2,00	1,0	1,50	6,3	4,50	6,0	04	Δ/Δ	Δ/Δ	Δ/Δ

▲ ab Lager / on stock Δ 4 Wochen / 4 weeks x auf Anfrage / upon request

● empfohlen / recommended

o bedingt einsetzbar / alternative recommendation

- nicht geeignet / not suitable

■ unbeschichtete HM-Sorten / uncoated grades

■ beschichtete HM-Sorten / coated grades

■ bestückt/Cermet / brazed/Cermet

Abmessungen in mm

Dimensions in mm

Ausführung R oder L angeben

State R or L version

Rechte WSP in rechten, linke WSP in linken Klemmhaltern verwenden.

Use right hand inserts in right hand toolholders and left hand inserts in left hand toolholders

P	●	●	●
M	o	-	●
K	o	-	●
N	-	-	●
S	-	-	●
H	-	-	-

HM-Sorten
Carbide grades

Einstechen (außen)

Grooving (external)



Wendeschneidplatte

Indexable insert

312

Poly-V-Riemennuten Profil „J“
Poly-V-belt grooves profile „J“

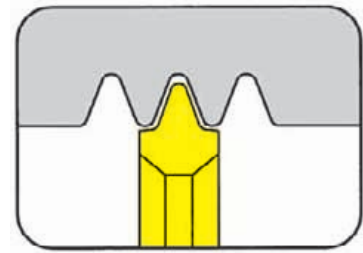

für Klemmhalter
for Toolholder

Typ ...23 = 340
Type ...30 = 360/369

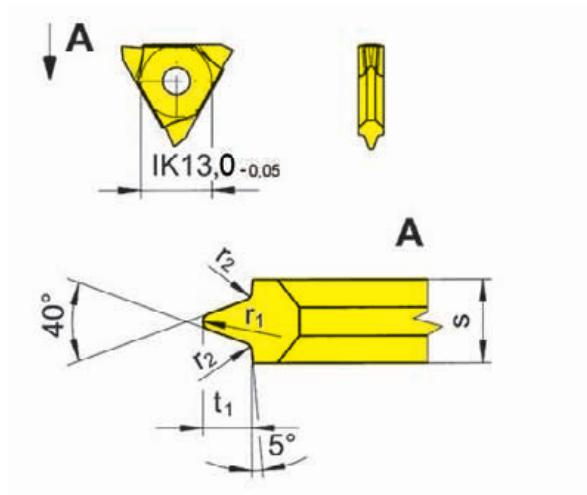

Wechselgenauigkeit
Länge ± 0,02 mm
Indexability length ± 0,02 mm

Bestellnummer Part number	r ₂	t ₁	s	r ₁	Größe Size	HM-Sorten Carbide grades		
						EG52	P20	TN32
312.0223.23	0,2	2,3	2,34	0,25	02	▲	▲	▲
312.0223.30	0,2	2,3	3,00	0,25	03	▲	▲	▲
						P	●	●
						M	○	-
						K	○	-
						N	-	-
						S	-	-
						H	-	-

▲ ab Lager / on stock Δ 4 Wochen / 4 weeks x auf Anfrage / upon request

● empfohlen / recommended

○ bedingt einsetzbar / alternative recommendation

- nicht geeignet / not suitable

□ unbeschichtete HM-Sorten / uncoated grades

■ beschichtete HM-Sorten / coated grades

■ bestückt/Cermet / brazed/Cermet

Abmessungen in mm

Dimensions in mm

WSP 312.0223.23 für Paket-Bestückung WSP 312.0223.30 für Einzel-Bestückung

Insert 312.0223.23 for multi grooving Insert 312.0223.30 for single grooving

Wendeschneidplatten sind in rechten und linken Klemmhaltern verwendbar.

Indexable inserts can be used in right and left hand toolholders.

Nutform:

Poly-V-Riemennut Profil „J“

Shape of groove:

Poly-V-belt grooves profile „J“



Einstechen und Abstechen

Grooving and Parting Off



N

Wendeschneidplatte

Indexable insert

312

mit runder Spanleitstufe
with round chip breaker

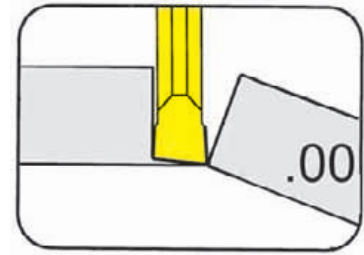

Stechtiefe bis Stechbreite	Depth of groove up to Width of groove	5,00 mm 1,44 mm
-------------------------------	--	--------------------

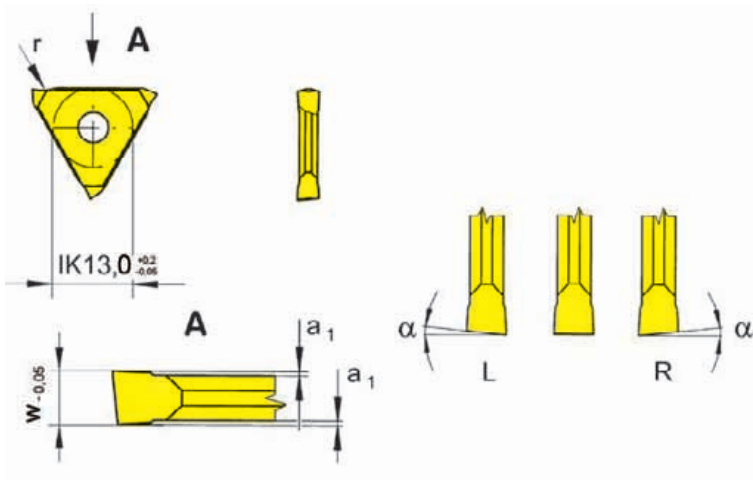

für Klemmhalter
for Toolholder

- Typ 309
Type 340
360
361
368
390
369
330
360C
360TS
N68
65

R = rechts wie gezeichnet
R = right hand version shown

L = links spiegelbildlich
L = left hand version

Bestellnummer Part number	w	α	a_1	Größe Size	EG35	TF45	TF46	TI25	TN35
R/L312.0614.00	1,44	6°	0,2	01	▲/▲	▲/▲	▲/▲	▲/▲	▲/▲

▲ ab Lager / on stock Δ 4 Wochen / 4 weeks x auf Anfrage / upon request

● empfohlen / recommended

o bedingt einsetzbar / alternative recommendation

- nicht geeignet / not suitable

■ unbeschichtete HM-Sorten / uncoated grades

■ beschichtete HM-Sorten / coated grades

■ bestückt/Cermet / brazed/Cermet

Abmessungen in mm

Dimensions in mm

Ausführung R oder L angeben

State R or L version

HM-Sorten

Carbide grades

P	●	●	●	●	●
M	●	●	○	●	●
K	○	●	●	●	●
N	-	●	●	●	●
S	-	●	○	●	●
H	-	-	-	-	-

Außenbearbeitung:

für Klemmhalter Typ 360 rechte WSP in linken, linke WSP in rechten Klemmhaltern verwenden.

External machining:

for Toolholder type 360 use right hand inserts in left hand toolholders and left hand inserts in right hand toolholders

Abstechen von Wellen

parting off solid bars

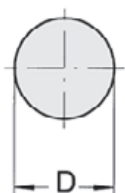

D bis 11 mm
D up to 11 mm

Abstechen von Ringen

parting off tubes

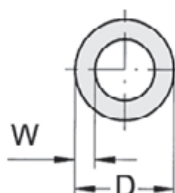

$D \geq 50$ mm bis $W \approx 5$ mm
 $D \leq 50$ mm bis $W \approx 4$ mm
 $D \geq 50$ mm up to $W \approx 5$ mm
 $D \leq 50$ mm up to $W \approx 4$ mm

Wendeschneidplatte

Indexable insert

312

mit runder Spanleitstufe
with round chip breaker

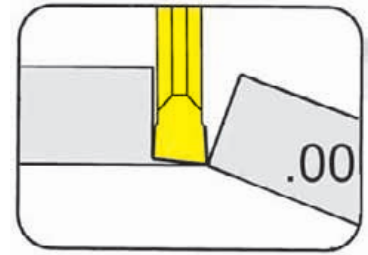

Stechtiefe bis	Depth of groove up to	8 mm
Stechbreite	Width of groove	0,5 - 1,5 mm

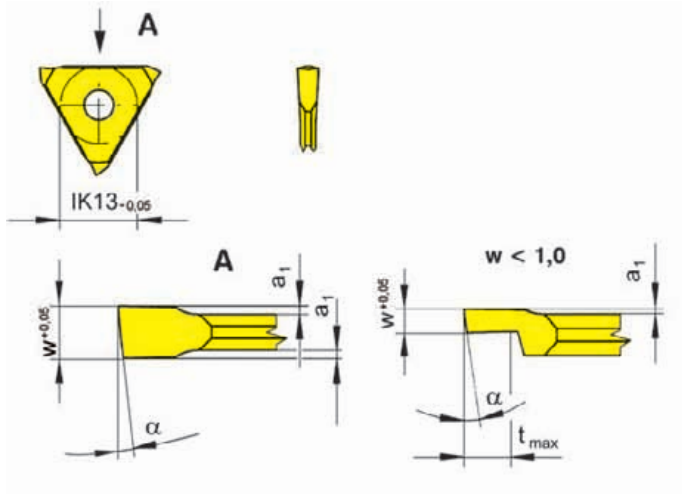

für Klemhalter
for Toolholder

- Typ 309
Type 340
360
361
368
390
369
330
360C
360TS
N68
65

R = rechts wie gezeichnet
R = right hand version shown

L = links spiegelbildlich
L = left hand version

Bestellnummer Part number	w	t _{max}	α	a ₁	Größe Size	K10	EG35	EG55	H20	P20	TC92	TF45	TF46	TI25	TN32	TN35
R/L312.0805.00	0,5	1,0	8°	0,1	01		▲/▲					▲/▲				
R/L312.0808.00	0,8	1,5	8°	0,1	01		▲/▲					▲/▲				
R/L312.0510.00	1,0	8,0	5°	0,1	01		▲/▲					▲/▲				
R/L312.1210.00	1,0	8,0	12°	0,1	01		▲/▲					▲/▲		Δ/Δ		▲/▲
R/L312.0512.00	1,2	8,0	5°	0,2	01		▲/▲					▲/▲				
R/L312.0515.00	1,5	8,0	5°	0,2	01	▲/x	▲/▲	▲/x	Δ/x	▲/x	Δ/x	▲/▲	▲/x		▲/x	
▲ ab Lager / on stock Δ 4 Wochen / 4 weeks x auf Anfrage / upon request						P	•	•	•	•	•	•	•	•	•	•
● empfohlen / recommended						M	○	•	○	○	-	-	○	•	-	•
○ bedingt einsetzbar / alternative recommendation						K	•	○	○	-	-	-	•	•	-	•
- nicht geeignet / not suitable						N	•	-	-	-	-	•	•	•	-	•
■ unbeschichtete HM-Sorten / uncoated grades						S	○	-	-	-	-	•	○	•	-	•
■ beschichtete HM-Sorten / coated grades						H	-	-	-	-	-	-	-	-	-	-
■ bestückt/Cermet / brazed/Cermet																

Abmessungen in mm
Dimensions in mm
Ausführung R oder L angeben
State R or L version

HM-Sorten
Carbide grades

Abstechen

Parting Off



Wendeschneidplatte

Indexable insert

312

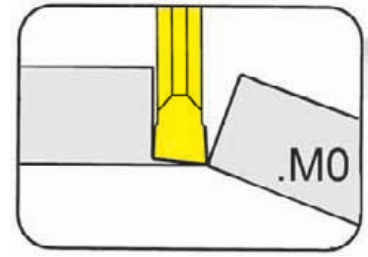

Stechtiefe bis Stechbreite	Depth of groove up to Width of groove	8 mm 1,2 - 1,5 mm
-------------------------------	--	----------------------

für Klemhalter
for Toolholder

- Typ 309
- Type 340
- 360
- 361
- 368
- 390
- 369
- 330
- 360C
- 360TS
- N68
- 65

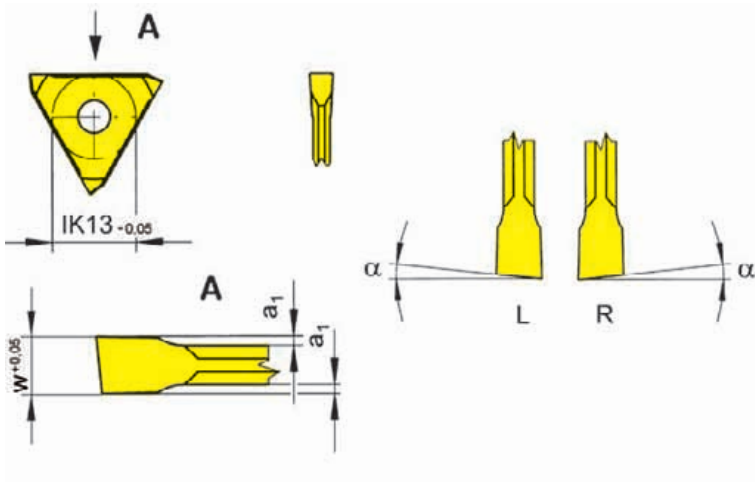

R = rechts wie gezeichnet
R = right hand version shown

L = links spiegelbildlich
L = left hand version

Bestellnummer Part number	w	t _{max}	α	a ₁	Größe Size	K10	EG35	TF45
R/L312.0512.M0	1,2	8	5°	0,2	01	Δ/Δ	▲/▲	▲/Δ
R/L312.0515.M0	1,5	8	5°	0,2	01	▲/Δ	▲/▲	▲/▲

- ▲ ab Lager / on stock Δ 4 Wochen / 4 weeks x auf Anfrage / upon request
- empfohlen / recommended
- o bedingt einsetzbar / alternative recommendation
- nicht geeignet / not suitable
- unbeschichtete HM-Sorten / uncoated grades
- beschichtete HM-Sorten / coated grades
- bestückt/Cermet / brazed/Cermet

Abmessungen in mm
Dimensions in mm
Ausführung R oder L angeben
State R or L version

	P	M	K	N	S	H
K10	●	●	●	●	●	-
EG35	●	●	●	-	-	-
TF45	●	●	●	●	●	-

HM-Sorten
Carbide grades

Wendeschneidplatte

Indexable insert

312

mit runder Spanleitstufe
with round chip breaker

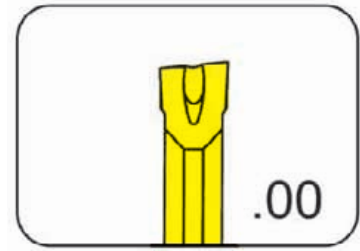

Stechtiefe bis Stechbreite	Depth of groove up to Width of groove	5 mm 1,44 - 2,29 mm
-------------------------------	--	------------------------

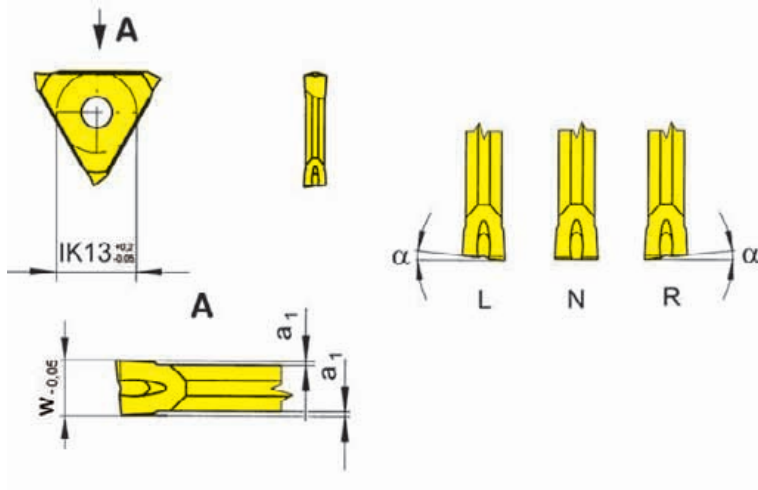

für Klemmhalter
for Toolholder

- Typ 309
- Type 340
- 360
- 361
- 368
- 390
- 369
- 330
- 360C
- 360TS
- N68
- 65

R = rechts wie gezeichnet
R = right hand version shown

L = links spiegelbildlich
L = left hand version

Bestellnummer Part number	w	α	a ₁	Größe Size
N312.0014.00	1,44	0°	0,2	01/02
N312.0018.00	1,99	0°	0,2	02
N312.0021.00	2,29	0°	0,2	02
R/L312.0514.00	1,44	5°	0,2	01/02
R/L312.0518.00	1,99	5°	0,2	02
R/L312.0521.00	2,29	5°	0,2	02

	MG12	EG55	P20	TC92	TF45	TN32	TN35
		▲		▲	▲		
		▲		▲	▲	▲	▲
		▲	▲	▲			▲
		▲/▲	▲/▲		▲/▲		
		▲/▲	▲/▲	▲/▲		▲/▲	▲/▲
	▲/▲	▲/▲	▲/▲	▲/▲		▲/▲	▲/▲
P	○	●	●	●	●	●	●
M	●	○	-	-	●	-	●
K	●	○	-	-	●	-	●
N	●	-	-	-	●	-	●
S	●	-	-	-	●	-	●
H	-	-	-	-	-	-	-

▲ ab Lager / on stock ▲ 4 Wochen / 4 weeks x auf Anfrage / upon request

● empfohlen / recommended

○ bedingt einsetzbar / alternative recommendation

- nicht geeignet / not suitable

□ unbeschichtete HM-Sorten / uncoated grades

■ beschichtete HM-Sorten / coated grades

■ bestückt/Cermet / brazed/Cermet

HM-Sorten
Carbide grades

Abmessungen in mm

Dimensions in mm

Ausführung R oder L angeben

State R or L version

Außenbearbeitung:

für Klemmhalter Typ 360 rechte WSP in linken, linke WSP in rechten Klemmhaltern verwenden.

External machining:

for Toolholder type 360 use right hand inserts in left hand toolholders and left hand inserts in right hand toolholders

Abstechen von Wellen
parting off solid bars

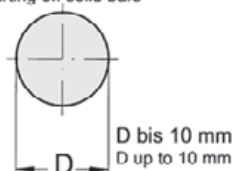

Abstechen von Rohren
parting off tubes

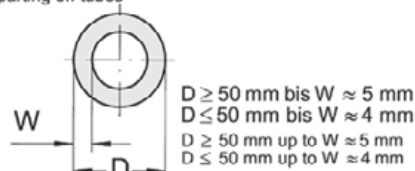

Axialeinstechen

Face Grooving



N

Wendeschneidplatte

Indexable insert

312

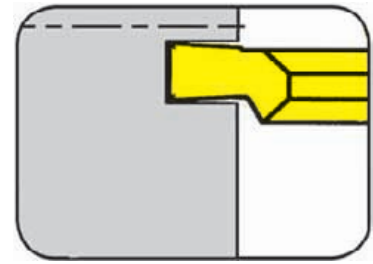

Nutaußen-Ø ab	from outer groove Ø	20 mm
Stechtiefe bis	Depth of groove up to	3 mm
Stechbreite	Width of groove	1,5 - 3 mm

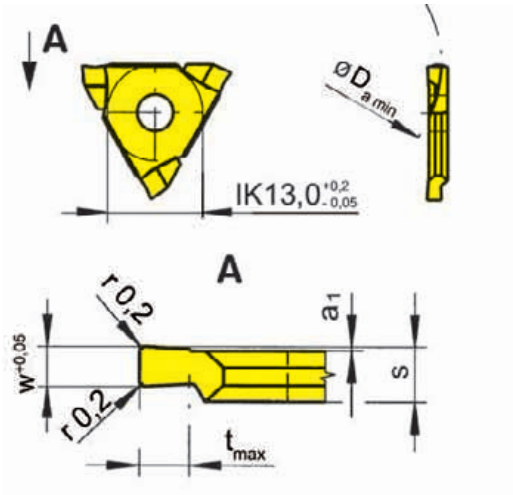

R = rechts wie gezeichnet
R = right hand version shown

L = links spiegelbildlich
L = left hand version

für Klemmhalter
for Toolholder

- Typ 309
- Type 340
- 360
- 361
- 368
- 390
- 369
- 330
- 360C
- 360TS
- N68
- 65

Wechselgenauigkeit
Länge ± 0,02 mm
Indexability length ± 0,02 mm

Bestellnummer Part number	w	t _{max}	a ₁	s	D _{amin}	Größe Size	MG12	EG55	TN35
R/L312.2015.02	1,5	2	0,2	2,7	20	02		▲/▲	▲/▲
R/L312.3020.02	2,0	3	0,2	2,7	30	02	x/Δ	▲/▲	▲/▲
R/L312.3030.02	3,0	3	0,2	3,7	30	03		▲/▲	▲/▲

▲ ab Lager / on stock Δ 4 Wochen / 4 weeks x auf Anfrage / upon request

● empfohlen / recommended

o bedingt einsetzbar / alternative recommendation

- nicht geeignet / not suitable

■ unbeschichtete HM-Sorten / uncoated grades

■ beschichtete HM-Sorten / coated grades

■ bestückt/Cermet / brazed/Cermet

Abmessungen in mm

Dimensions in mm

Ausführung R oder L angeben

State R or L version

Hinweis für Klemmhalter Typ 360

Rechte WSP in linken, linke WSP in rechten Klemmhaltern verwenden.

Note for toolholder type 360

Use right hand inserts in left hand toolholders and left hand inserts in right hand toolholders

Hinweis für Klemmhalter Typ 369

Rechte WSP in rechten, linke WSP in linken Klemmhaltern verwenden.

Note for toolholder type 369

Use right hand inserts in right hand toolholders and left hand inserts in left hand toolholders

P	o	•	•
M	•	o	•
K	•	o	•
N	•	-	•
S	•	-	•
H	-	-	-

HM-Sorten
Carbide grades



315



**Klemmhalter mit
Schneidplatten**

Stechbreite 0,5 - 8 mm

**Toolholder with
Inserts**

Width of groove 0,5 - 8 mm

Klemmhalter
Toolholder
356/357/333

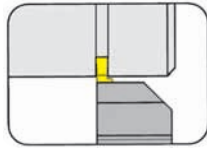

Seite/Page
O3-O6, O9

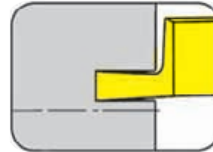

Seite/Page
O19-O20

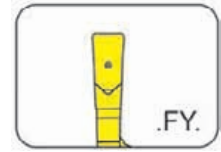

Seite/Page
O30

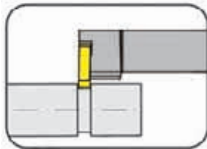

Seite/Page
O7-O8

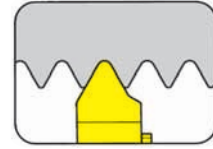

Seite/Page
O21

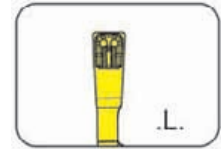

Seite/Page
O31

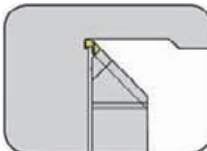

Seite/Page
O10

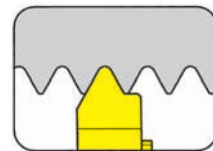

Seite/Page
O22, O25

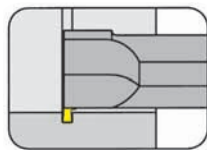

Seite/Page
O11

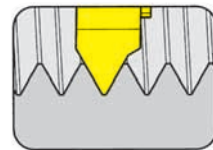

Seite/Page
O23

Kurzklammhalter
Cartridge
357

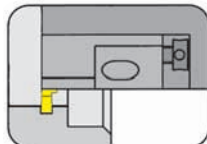

Seite/Page
O12

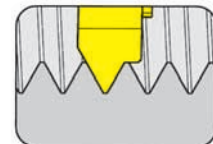

Seite/Page
O24

Wendeschneidplatte
Indexable insert
315/A315/S315

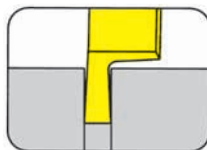

Seite/Page
O14-O16

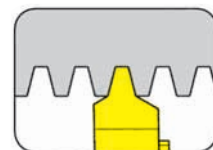

Seite/Page
O26



Seite/Page
O17



Seite/Page
O28



Seite/Page
O18, O20



Seite/Page
O29

Einstecken/Gewindedrehen (außen)

Grooving and Threading (external)



Klemmhalter

Toolholder

356

Stechtiefe bis Stechbreite	Depth of groove up to Width of groove	5,0 mm 0,5 - 7,3 mm
-------------------------------	--	------------------------

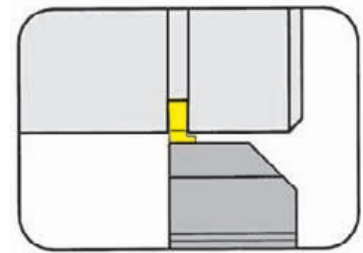

für Wendeschneidplatte
for Indexable insert

Typ 315
Type A315

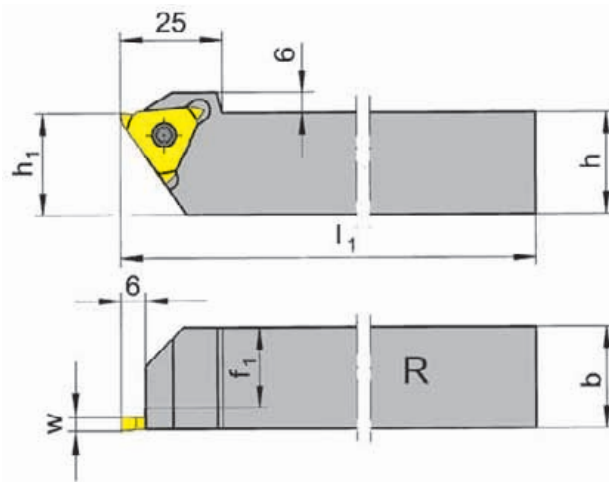

R = rechts wie gezeichnet
R = right hand version shown

L = links spiegelbildlich
L = left hand version

Bestellnummer Part number	h	b	l ₁	h ₁	f ₁	Größe Size
R/L356.1616.03	16	16	125	20	13,0	03
R/L356.2020.03	20	20	125	20	17,0	03
R/L356.2525.03	25	25	150	25	22,0	03
R/L356.3232.03	32	32	170	32	29,0	03
R/L356.1616.05	16	16	125	20	10,8	05
R/L356.2020.05	20	20	125	20	14,8	05
R/L356.2525.05	25	25	150	25	19,8	05
R/L356.3232.05	32	32	170	32	26,8	05
R/L356.2020.07	20	20	125	20	13,0	07
R/L356.2525.07	25	25	150	25	18,0	07
R/L356.3232.07	32	32	170	32	25,0	07

Ausführung R oder L angeben
State R or L version

w siehe WSP
w see indexable inserts

Abmessungen in mm
Dimensions in mm

Weitere Abmessungen auf Anfrage
Further sizes upon request

Das Anzugsdrehmoment der Schrauben finden Sie in den Technischen Hinweisen.
For torque specification of the screw, please see Technical Instructions.

Ersatzteile

Spare Parts

Klemmhalter Toolholder	Spannschraube Screw	TORX PLUS®-Schlüssel TORX PLUS® Wrench
R/L356...	5.12T20P	T20PQ
R/L356.2525.07	5.15T20P	T20PQ

Einstechen und Abstechen

Grooving and Parting Off



Klemmhalter

Toolholder

356

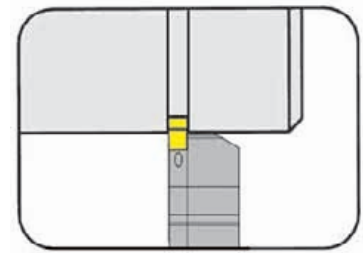

Stechtiefe bis	Depth of groove up to	5,0 mm
Stechbreite	Width of groove	0,5 - 5,3 mm

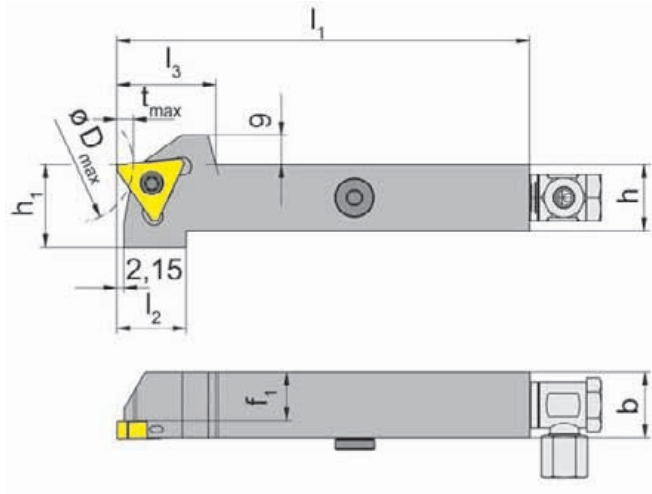

für Wendeschneidplatte
for Indexable insert

Typ 315
Type A315

Stechtiefe in Abhängigkeit des Außen-Ø
Depth of groove in relation to outer-Ø

D _{max}	t _{max}
30	5,0
40	4,5
60	4,0
115	3,5
185	3,0

mit integrierter innerer
Kühlmittelzufuhr
with integrated through
coolant supply

R = rechts wie gezeichnet
R = right hand version shown

L = links spiegelbildlich
L = left hand version

Bestellnummer Part number	h	b	l ₁	l ₂	l ₃	h ₁	f ₁	Größe Size
R/L356.1616.0.13.IK	16	16	125	22	28	21	13,0	03
R/L356.2020.0.13.IK	20	20	125	21	30	25	17,0	03
R/L356.2525.0.13.IK	25	25	150	21	30	30	22,0	03
R/L356.1616.0.15.IK	16	16	125	22	28	21	10,8	05
R/L356.2020.0.15.IK	20	20	125	21	30	25	14,8	05
R/L356.2525.0.15.IK	25	25	150	21	30	30	19,8	05

Ausführung R oder L angeben
State R or L version

Abmessungen in mm
Dimensions in mm

Weitere Abmessungen auf Anfrage
Further sizes upon request

Das Anzugsdrehmoment der Schrauben finden Sie in den Technischen Hinweisen.
For torque specification of the screw, please see Technical Instructions.

Ersatzteile

Spare Parts

Klemmhalter Toolholder	Spannschraube Screw	Kühlmittelanschluss Coolant supply	TORX PLUS®-Schlüssel TORX PLUS® Wrench	Verschluss-Stopfen Sealing plug
R/L356...	5.12T20P	004.00.16	T20PQ	004.00.26

Einstechen/Gewindedrehen (außen)

Grooving and Threading (external)



Klemmhalter

Toolholder

356

Stechtiefe bis Stechbreite	Depth of groove up to Width of groove	5,0 mm 0,5 - 10,3 mm
-------------------------------	--	-------------------------

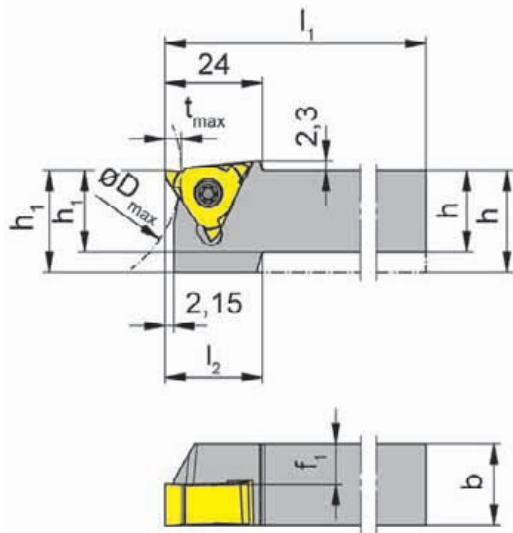
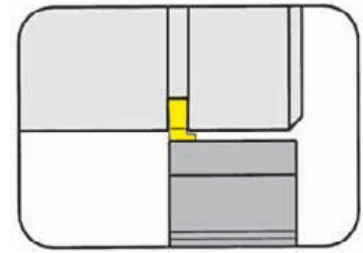

für Wendeschneidplatte
for Indexable insert

Typ 315
Type A315

Stechtiefe in Abhängigkeit des Außen-Ø
Depth of groove in relation to outer-Ø

D _{max}	t _{max}
30	5,0
40	4,5
60	4,0
115	3,5
185	3,0

R = rechts wie gezeichnet
R = right hand version shown

L = links spiegelbildlich
L = left hand version

Bestellnummer Part number	h	b	l ₁	l ₂	h ₁	f ₁	Größe Size
R/L356.1616.13	16	16	125	21	20	13,0	03
R/L356.2020.13	20	20	125	-	20	17,1	03
R/L356.2525.13	25	25	150	-	25	22,1	03
R/L356.1616.15	16	16	125	21	20	10,8	05
R/L356.2020.15	20	20	125	21	20	14,8	05
R/L356.2525.15	25	25	150	-	25	19,8	05
R/L356.1616.16	16	16	125	-	20	10,0	06
R/L356.2020.16	20	20	125	21	25	14,0	06
R/L356.2525.16	25	25	150	-	25	19,0	06
R/L356.2020.17	20	20	125	21	25	13,0	07
R/L356.2525.17	25	25	150	-	25	18,1	07
R/L356.2020.10	20	20	125	21	25	10,0	10

Ausführung R oder L angeben
State R or L version

Abmessungen in mm
Dimensions in mm

Weitere Abmessungen auf Anfrage
Further sizes upon request

Das Anzugsdrehmoment der Schrauben finden Sie in den Technischen Hinweisen.
For torque specification of the screw, please see Technical Instructions.

Ersatzteile

Spare Parts

Klemmhalter Toolholder	Spannschraube Screw	TORX PLUS®-Schlüssel TORX PLUS® Wrench
R/L356...	5.12T20P	T20PQ
R/L356.2020.16	5.15T20P	T20PQ
R/L356...17/10	5.15T20P	T20PQ

Einstecken/Gewindedrehen (außen)

Grooving and Threading (external)



Klemmhalter

Toolholder

356

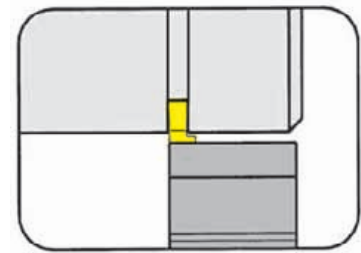

Stechtiefe bis Stechbreite	Depth of groove up to Width of groove	5,0 mm 10,3 - 13,3 mm
-------------------------------	--	--------------------------

für Wendeschneidplatte
for Indexable insert

Typ 315
Type A315

Stechtiefe in Abhängigkeit des Außen-Ø
Depth of groove in relation to outer-Ø

D _{max}	t _{max}
30	5,0
40	4,5
60	4,0
115	3,5
185	3,0

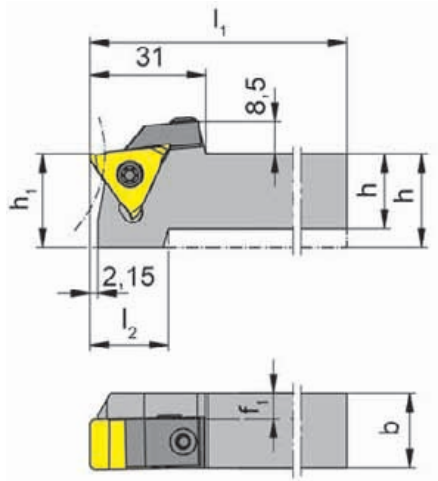

R = rechts wie gezeichnet
R = right hand version shown

L = links spiegelbildlich
L = left hand version

Bestellnummer Part number	h	b	l ₁	l ₂	h ₁	f ₁	Größe Size
R/L356.2020.2.13	20	20	125	21	20	7	13
R/L356.2525.2.13	25	25	150	-	25	12	13

Ausführung R oder L angeben
State R or L version

Abmessungen in mm
Dimensions in mm

Weitere Abmessungen auf Anfrage
Further sizes upon request

Das Anzugsdrehmoment der Schrauben finden Sie in den Technischen Hinweisen.
For torque specification of the screw, please see Technical Instructions.

Ersatzteile

Spare Parts

Klemmhalter Toolholder	Spannschraube Screw	Spannelement Clamping element	TORX PLUS®-Schlüssel TORX PLUS® Wrench
R/L356.2020.2.13	5.12T20P	010.2013.0468	T20PQ
R/L356.2525.2.13	5.15T20P	010.2013.0468	T20PQ

Einstecken/Gewindedrehen (außen)

Grooving and Threading (external)



Klemmhalter

Toolholder

357

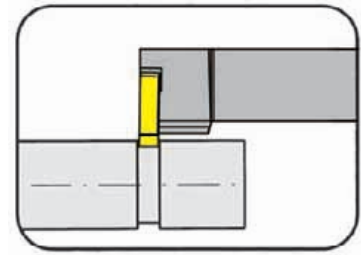

Stechtiefe bis Stechbreite	Depth of groove up to Width of groove	5,0 mm 0,5 - 5,3 mm
-------------------------------	--	------------------------

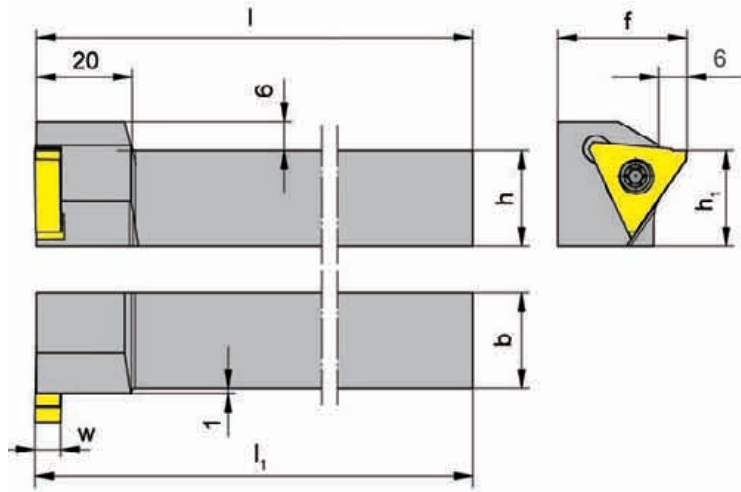

für Wendeschneidplatte
for Indexable insert

Typ 315
Type A315

R = rechts wie gezeichnet
R = right hand version shown

L = links spiegelbildlich
L = left hand version

Bestellnummer Part number	h	b	l ₁	h ₁	f	l	Größe Size
R/L357.2020.05	20	20	125,3	20	27	125	05
R/L357.2525.05	25	25	150,3	25	32	150	05

Ausführung R oder L angeben
State R or L version

w siehe WSP
w see indexable inserts

Abmessungen in mm
Dimensions in mm

Weitere Abmessungen auf Anfrage
Further sizes upon request

Further sizes upon request

Bestellhinweis:

Rechte WSP in linken, linke WSP in rechten Klemmhaltern verwenden.

Ordering note:

Use right hand inserts in left hand toolholders and left hand inserts in right hand toolholders

Das Anzugsdrehmoment der Schrauben finden Sie in den Technischen Hinweisen.

For torque specification of the screw, please see Technical Instructions.

Ersatzteile

Spare Parts

Klemmhalter Toolholder	Spannschraube Screw	TORX PLUS®-Schlüssel TORX PLUS® Wrench
R/L357...	5.12T20P	T20PQ

Einstecken/Gewindedrehen (außen)

Grooving and Threading (external)



Klemmhalter

Toolholder

357

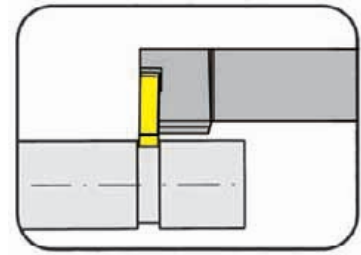

Stechtiefe bis Stechbreite	Depth of groove up to Width of groove	5,0 mm 0,5 - 5,3 mm
-------------------------------	--	------------------------

für Wendeschneidplatte
for Indexable insert

Typ 315
Type A315

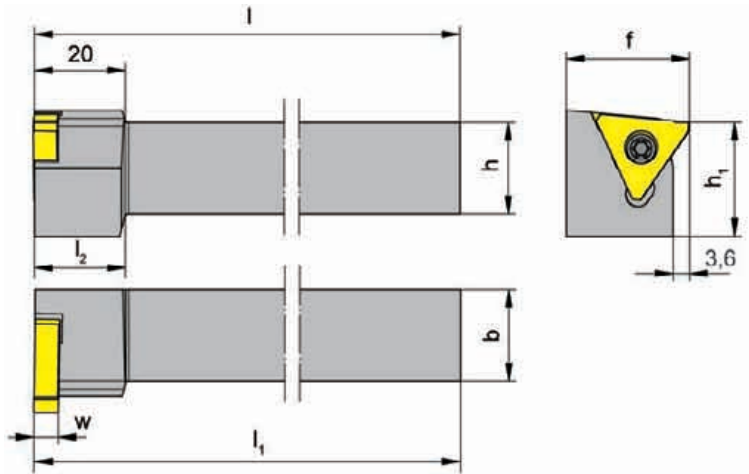

R = rechts wie gezeichnet
R = right hand version shown

L = links spiegelbildlich
L = left hand version

Bestellnummer Part number	h	b	l ₁	l ₂	h ₁	f	l	Größe Size
R/L357.2020.15	20	20	125,3	20	25	27	125	05
R/L357.2525.15	25	25	150,3	-	25	32	150	05

Ausführung R oder L angeben
State R or L version

w siehe WSP
w see indexable inserts

Abmessungen in mm
Dimensions in mm

Weitere Abmessungen auf Anfrage
Further sizes upon request

Further sizes upon request

Bestellhinweis:

Rechte WSP in linken, linke WSP in rechten Klemmhaltern verwenden.

Ordering note:

Use right hand inserts in left hand toolholders and left hand inserts in right hand toolholders

Das Anzugsdrehmoment der Schrauben finden Sie in den Technischen Hinweisen.

For torque specification of the screw, please see Technical Instructions.

Ersatzteile

Spare Parts

Klemmhalter Toolholder	Spannschraube Screw	TORX PLUS®-Schlüssel TORX PLUS® Wrench
R/L357...	5.12T20P	T20PQ

Einstechen (außen)

Grooving (external)



Klemmhalter

Toolholder

356

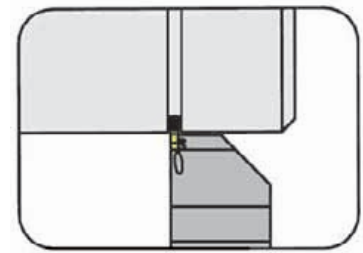

Stechtiefe bis Stechbreite	Depth of groove up to Width of groove	6 mm 1,1 - 2 mm
-------------------------------	--	--------------------

für Wendeschneidplatte
for Indexable insert

Typ S315
Type

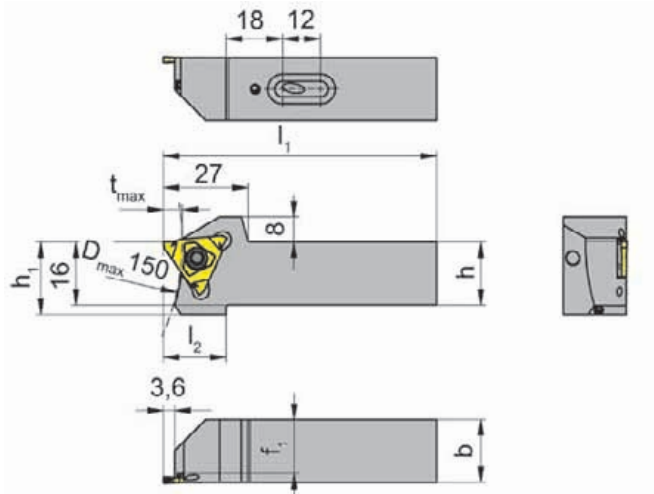

R = rechts wie gezeichnet
R = right hand version shown

L = links spiegelbildlich
L = left hand version

Bestellnummer Part number	h	b	l ₁	l ₂	h ₁	f ₁	t _{max}	Größe Size
R/L356.1616.S.4.03.IK	16	16	74	20	23	13,2	6	03
R/L356.2020.S.4.03.IK	20	20	87	20	23	17,2	6	03
R/L356.2525.S.4.03.IK	25	25	104	20	28	22,2	6	03

Ausführung R oder L angeben
State R or L version

Abmessungen in mm
Dimensions in mm

Weitere Abmessungen auf Anfrage
Further sizes upon request

Bestellhinweis:

Rechte WSP in linken, linke WSP in rechten Klemmhaltern verwenden.

Ordering note:

Use right hand inserts in left hand toolholders and left hand inserts in right hand toolholders

Das Anzugsdrehmoment der Schrauben finden Sie in den Technischen Hinweisen.

For torque specification of the screw, please see Technical Instructions.

Ersatzteile

Spare Parts

Klemmhalter Toolholder	Spannschraube Screw	TORX PLUS®-Schlüssel TORX PLUS® Wrench
R/L356...	5.12T20P	T20PQ

Eckenfreistechen (außen)

Grooving Corner Reliefs (external)



O

Klemmhalter
Toolholder

356

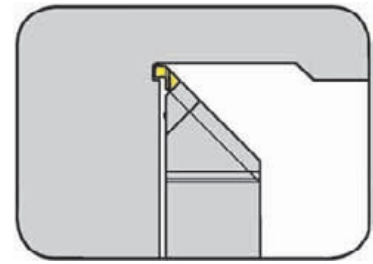

Eckenfreistiche (45°)
Corner reliefs (45°)

für Wendeschneidplatte
for Indexable insert

Typ LA315...R
Type RA315...L

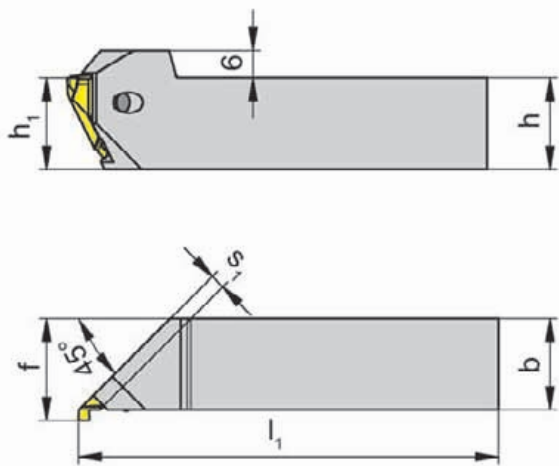

R = rechts wie gezeichnet
R = right hand version shown

L = links spiegelbildlich
L = left hand version

Bestellnummer Part number	h	b	l ₁	h ₁	f	s ₁	Größe Size
R/L356.2020.45.03	20	20	125	20	22,3	3,25	03
R/L356.2525.45.03	25	25	150	25	27,3	3,25	03

Ausführung R oder L angeben
State R or L version

Abmessungen in mm
Dimensions in mm

Bestellhinweis:

Rechte WSP in linken, linke WSP in rechten Klemmhaltern verwenden.

Ordering note:

Use right hand inserts in left hand toolholders and left hand inserts in right hand toolholders

Das Anzugsdrehmoment der Schrauben finden Sie in den Technischen Hinweisen.

For torque specification of the screw, please see Technical Instructions.

Ersatzteile

Spare Parts

Klemmhalter Toolholder	Spannschraube Screw	TORX PLUS®-Schlüssel TORX PLUS® Wrench
R/L356...	5F.08T20P	T20PQ

Einstecken/Gewindedrehen (innen)

Grooving/Threading (internal)



Klemmhalter

Toolholder

333

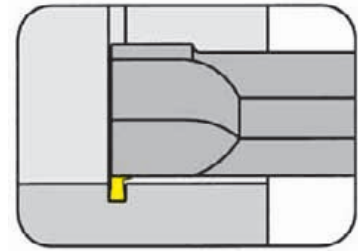

Bohrungs-Ø ab Stechbreite	Bore Ø from Width of groove	43 mm 0,5 - 5,3 mm
------------------------------	--------------------------------	-----------------------

für Wendeschneidplatte
for Indexable insert

Typ 315
Type A315

Stechtiefe in Abhängigkeit des Bohrungs-Ø
Depth of groove in relation to bore Ø

D _{min}	t _{max}
43	1,8
46	2,0
50	3,0
60	4,0
80	4,5
100	5,0

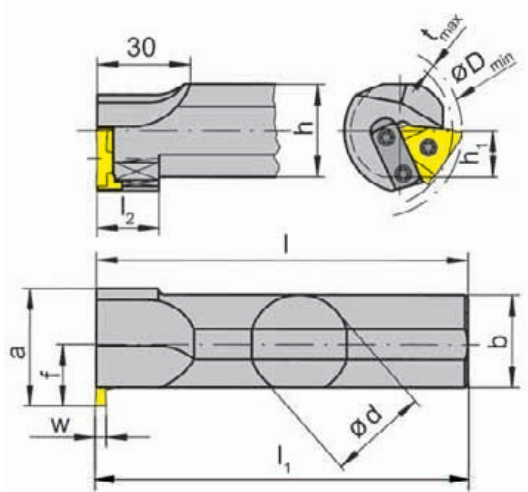

R = rechts wie gezeichnet
R = right hand version shown

L = links spiegelbildlich
L = left hand version

Bestellnummer Part number	d	l	l ₁	h	a	h ₁	l ₂	D _{min}	b	f	Größe Size
R/L333.0025.03	25	170	170,3	23	38	11,5	20	43	25	20	03
R/L333.0032.03	32	200	200,3	30	38	15,0	20	43	30	20	03
R/L333.0025.05	25	170	170,3	23	38	11,5	20	43	25	20	05
R/L333.0032.05	32	200	200,3	30	38	15,0	20	43	30	20	05
R/L333.0040.05	40	250	250,3	38	44	19,0	-	45	38	24	05

Ausführung R oder L angeben
State R or L version

w siehe WSP
w see indexable inserts

Abmessungen in mm
Dimensions in mm

Weitere Abmessungen auf Anfrage
Further sizes upon request

Bestellhinweis:

Rechte WSP in linken, linke WSP in rechten Klemmhaltern verwenden.

Ordering note:

Use right hand inserts in left hand toolholders and left hand inserts in right hand toolholders

Das Anzugsdrehmoment der Schrauben finden Sie in den Technischen Hinweisen.

For torque specification of the screw, please see Technical Instructions.

Ersatzteile

Spare Parts

Klemmhalter Toolholder	Anlageleiste Attachment bar	Spannschraube Screw	TORX PLUS®-Schlüssel TORX PLUS® Wrench
R/L333...	020.7000.0193	5.12T20P	T20PQ

Einstecken/Gewindedrehen (innen)

Grooving/Threading (internal)



Kurzklemmhalter

Cartridge

357

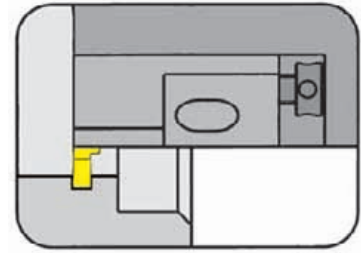

Bohrungs-Ø ab
Stechbreite

Bore Ø from
Width of groove

50,0 mm
0,5-5,3 mm

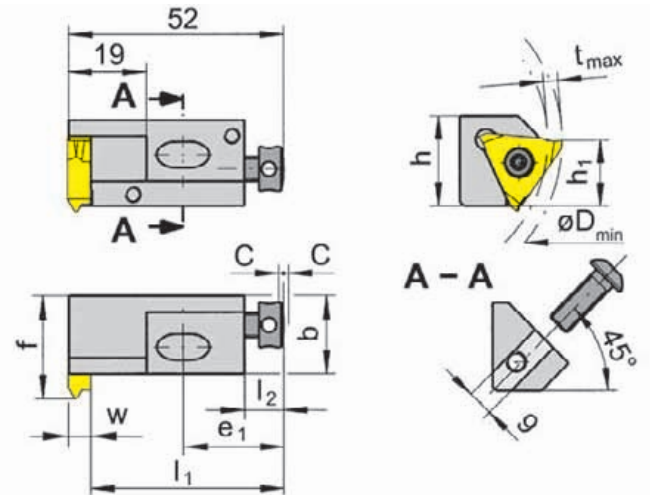

für Wendeschneidplatte
for Indexable insert

Typ 315
Type A315

Stechtiefe in Abhängigkeit des Bohrungs-Ø
Depth of groove in relation to bore Ø

D _{min}	t _{max}
50	3,0
60	4,0
80	4,5
100	5,0

R = rechts wie gezeichnet
R = right hand version shown

L = links spiegelbildlich
L = left hand version

Bestellnummer Part number	h	b	h ₁	f	l ₁	e ₁	l ₂	C	Größe Size
R/L357.1619.05	21	19	16	25	46,8	24	9	2	05

Ausführung R oder L angeben
State R or L version

w siehe WSP
w see indexable inserts

Abmessungen in mm
Dimensions in mm

Einbaumaße siehe Folgeseite
Dimensions of seating see following page

Bestellhinweis:

Rechte WSP in linken, linke WSP in rechten Klemmhaltern verwenden.

Ordering note:

Use right hand inserts in left hand toolholders and left hand inserts in right hand toolholders

Das Anzugsdrehmoment der Schrauben finden Sie in den Technischen Hinweisen.

For torque specification of the screw, please see Technical Instructions.

Ersatzteile

Spare Parts

Kurzklemmhalter Cartridge	Spannschraube Screw	Inbus-Schlüssel Wrench	TORX PLUS®-Schlüssel TORX PLUS® Wrench
R/L357.1619.05	4.08.913	SW2,0 DIN911	T20PQ

Einstecken (innen)

Grooving (internal)



Einbaumaße Kurzklemmhalter

Seating Dimensions Cartridge

357

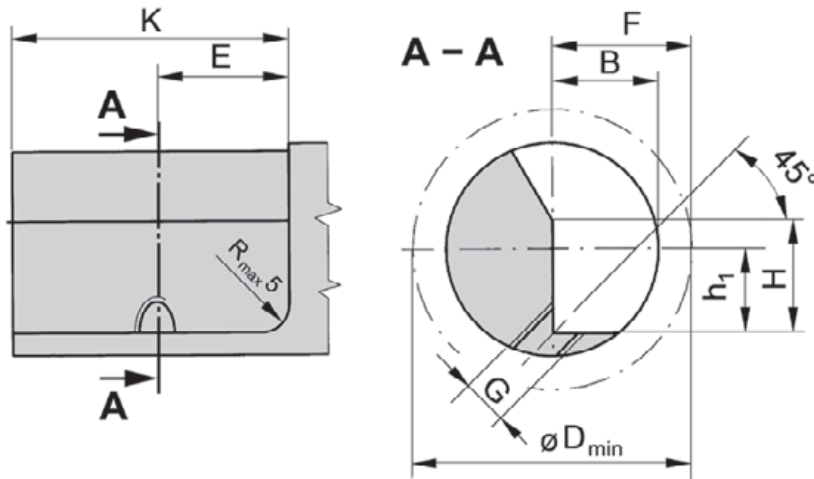
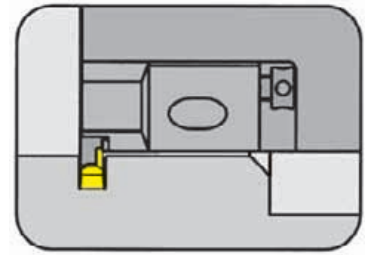

Kurzklemmhalter Cartridge	F	G	H	K	E	B	h_1	D_{min}	Befestigungsschraube Fastening screw
357.1619.05	25	M8	21	50	24	19	16	50	8.25.351

Abmessungen in mm
Dimensions in mm

Einstechen (außen)

Grooving (external)



Wendeschneidplatte

315

Indexable insert

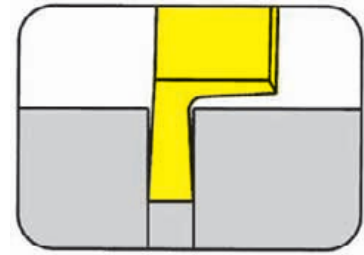

Seegerringnuten
Nutnennbreite Nw

Circlip grooves
Width of circlip Nw

DIN471/472
0,5-1 mm

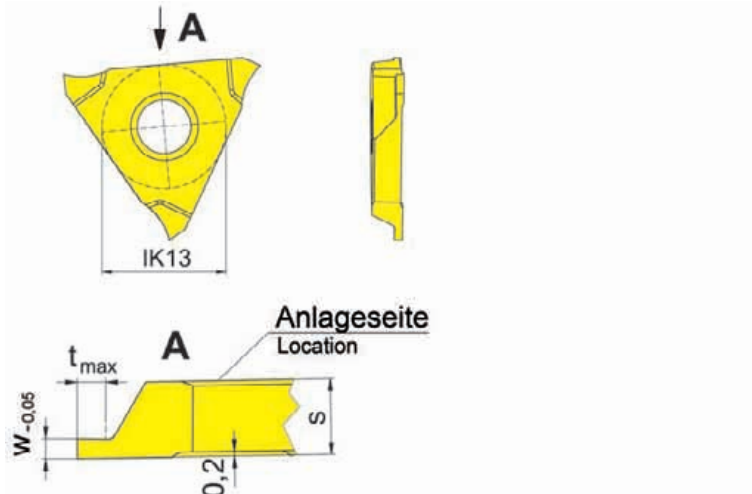

für Klemmhalter
for Toolholder

Typ 356...03
Type

R = rechts wie gezeichnet
R = right hand version shown

L = links spiegelbildlich
L = left hand version

Bestellnummer Part number	w	Nw	t_{max}	s	Größe Size	TN32
R/L315.0050.32.00	0,57	0,5	0,7	3,2	03	▲/△
R/L315.0060.32.00	0,67	0,6	0,8	3,2	03	▲/△
R/L315.0070.32.00	0,77	0,7	1,1	3,2	03	▲/△
R/L315.0080.32.00	0,87	0,8	1,2	3,2	03	▲/△
R/L315.0090.32.00	0,97	0,9	1,4	3,2	03	▲/△
R/L315.0100.32.00	1,07	1,0	1,6	3,2	03	▲/△

▲ ab Lager / on stock Δ 4 Wochen / 4 weeks x auf Anfrage / upon request

● empfohlen / recommended

o bedingt einsetzbar / alternative recommendation

- nicht geeignet / not suitable

■ unbeschichtete HM-Sorten / uncoated grades

■ beschichtete HM-Sorten / coated grades

■ bestückt/Cermet / brazed/Cermet

P	•
M	-
K	-
N	-
S	-
H	-

Abmessungen in mm

Dimensions in mm

Ausführung R oder L angeben

State R or L version

HM-Sorten
Carbide grades

Außenbearbeitung:

Rechte WSP in rechten Klemmhalter 356, linke WSP in linken Klemmhaltern 356 verwenden.

External machining:

Right hand insert in right hand toolholder 356, left hand insert in left hand toolholder 356.

Einstecken (außen und innen)

Grooving (external and internal)



Wendeschneidplatte

Indexable insert

315

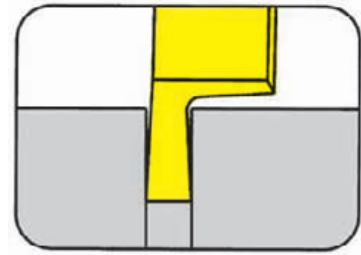

Seegerringnuten Nutnennbreite Nw	Circlip grooves Width of circlip Nw	DIN471/472 1,1-5,15 mm
-------------------------------------	--	---------------------------

für Klemmhalter
for Toolholder

Typ 356
Type 357
333

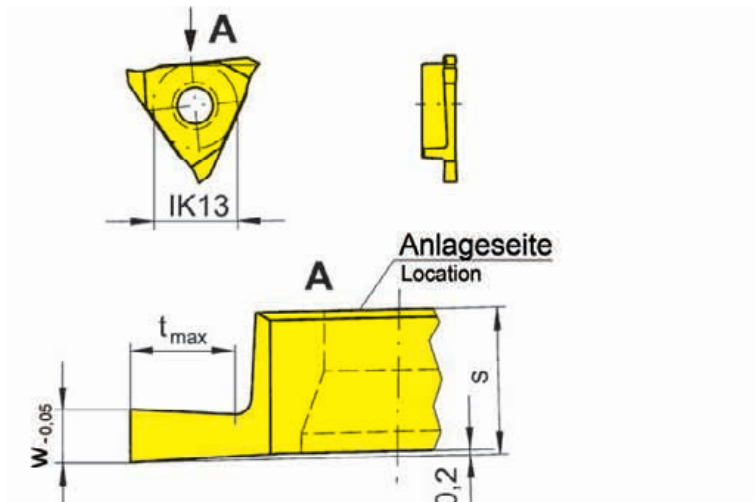

R = rechts wie gezeichnet
R = right hand version shown

L = links spiegelbildlich
L = left hand version

Bestellnummer Part number	w	Nw	t _{max}	s	Größe Size	AL96	AS42	AS46	TC92	TF45	TN35
R/L315.0110.00	1,24	1,10	2	5,4	05	Δ/Δ	▲/▲	Δ/Δ	Δ/Δ	▲/Δ	▲/▲
R/L315.0130.00	1,44	1,30	2	5,4	05	Δ/Δ	▲/▲	Δ/Δ	Δ/Δ	▲/▲	▲/▲
R/L315.0160.00	1,74	1,60	3	5,4	05	Δ/Δ	▲/▲	Δ/Δ	Δ/Δ	Δ/Δ	▲/▲
R/L315.0185.00	1,99	1,85	3	5,4	05	Δ/Δ	▲/▲	Δ/Δ	Δ/Δ	Δ/Δ	▲/▲
R/L315.0215.00	2,29	2,15	4	5,4	05	Δ/Δ	▲/▲	Δ/Δ	Δ/Δ	Δ/Δ	▲/▲
R/L315.0265.00	2,79	2,65	4	5,4	05	Δ/Δ	▲/▲	Δ/Δ	Δ/Δ	Δ/Δ	▲/▲
R/L315.0315.00	3,29	3,15	5	5,4	05	Δ/Δ	▲/▲	Δ/Δ	Δ/Δ	▲/Δ	▲/▲
R/L315.0415.00	4,29	4,15	5	5,4	05	Δ/Δ	▲/▲	Δ/Δ	Δ/Δ	▲/Δ	▲/▲
R/L315.0515.00	5,29	5,15	5	5,4	05	Δ/Δ	▲/▲	Δ/Δ	Δ/Δ	▲/Δ	▲/▲

▲ ab Lager / on stock Δ 4 Wochen / 4 weeks x auf Anfrage / upon request

● empfohlen / recommended

o bedingt einsetzbar / alternative recommendation

- nicht geeignet / not suitable

□ unbeschichtete HM-Sorten / uncoated grades

■ beschichtete HM-Sorten / coated grades

■ bestückt/Cermet / brazed/Cermet

P	●	●	●	●	●	●
M	-	●	●	-	●	●
K	●	●	●	-	●	●
N	●	●	●	-	●	●
S	-	●	●	-	●	●
H	-	-	-	-	-	-

Abmessungen in mm

Dimensions in mm

Ausführung R oder L angeben

State R or L version

HM-Sorten

Carbide grades

Außenbearbeitung:

Rechte WSP in rechten Klemmhalter 356, linke WSP in linken Klemmhaltern 356 verwenden.

External machining:

Right hand insert in right hand toolholder 356, left hand insert in left hand toolholder 356.

Innenbearbeitung:

Rechte WSP in linken Klemmhalter 333/357, linke WSP in rechten Klemmhaltern 333/357 verwenden.

Internal machining:

Right hand insert in left hand toolholder 333/357, left hand insert in right hand toolholder 333/357.

Wendeschneidplatte

Indexable insert

315

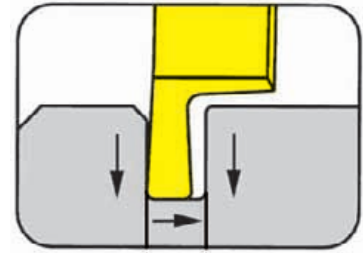

Stechtiefe bis Stechbreite	Depth of groove up to Width of groove	5 mm 2-8 mm
-------------------------------	--	----------------

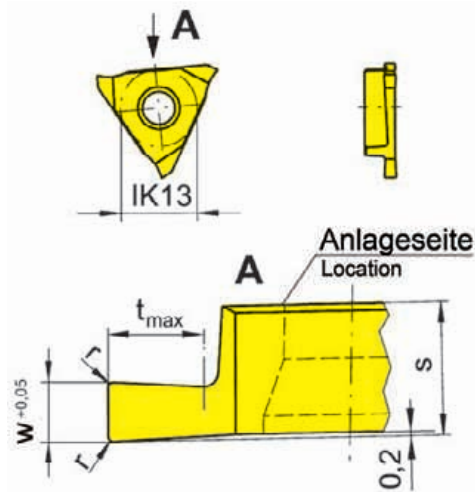

für Klemhalter
for Toolholder

Typ 356
Type 357
333

R = rechts wie gezeichnet
R = right hand version shown

L = links spiegelbildlich
L = left hand version

Wechselgenauigkeit
Länge ± 0,02 mm
Indexability length ± 0,02 mm

Bestellnummer Part number	w	r	t _{max}	s	Größe Size	AL96	AS42	AS45	AS46	TC92	TF45	TN35
R/L315.0200.02	2	0,2	3	5,4	05	Δ/Δ	▲/▲		Δ/Δ	Δ/Δ	Δ/Δ	▲/▲
R/L315.0200.04	2	0,4	3	5,4	05	Δ/Δ	▲/▲		Δ/Δ	Δ/Δ	Δ/Δ	▲/Δ
R/L315.0300.02	3	0,2	4	5,4	05	Δ/Δ	▲/▲		Δ/Δ	Δ/Δ	Δ/Δ	▲/▲
R/L315.0300.04	3	0,4	4	5,4	05	Δ/Δ	▲/Δ		Δ/Δ	Δ/Δ	Δ/Δ	▲/▲
R/L315.0400.02	4	0,2	5	5,4	05		▲/▲		Δ/Δ			▲/▲
R/L315.0400.04	4	0,4	5	5,4	05		▲/▲		Δ/Δ			▲/▲
R/L315.0500.02	5	0,2	5	5,4	05			▲/▲				
R/L315.0600.04	6	0,4	5	6,4	06			▲/▲				
R/L315.0800.04	8	0,4	5	8,4	07			▲/▲				

▲ ab Lager / on stock Δ 4 Wochen / 4 weeks x auf Anfrage / upon request

● empfohlen / recommended

o bedingt einsetzbar / alternative recommendation

- nicht geeignet / not suitable

unbeschichtete HM-Sorten / uncoated grades

beschichtete HM-Sorten / coated grades

bestückt/Cermet / brazed/Cermet

P	•	•	•	•	•	•	•
M	-	•	•	•	-	•	•
K	•	•	•	•	-	•	•
N	•	•	o	•	-	•	•
S	-	•	•	•	-	•	•
H	-	-	-	-	-	-	-

Abmessungen in mm

Dimensions in mm

Ausführung R oder L angeben

State R or L version

HM-Sorten

Carbide grades

Außenbearbeitung:

Rechte WSP in rechten Klemmhalter 356, linke WSP in linken Klemmhaltern 356 verwenden.

External machining:

Right hand insert in right hand toolholder 356, left hand insert in left hand toolholder 356.

Innenbearbeitung:

Rechte WSP in linken Klemmhalter 333/357, linke WSP in rechten Klemmhaltern 333/357 verwenden.

Internal machining:

Right hand insert in left hand toolholder 333/357, left hand insert in right hand toolholder 333/357.

Einstecken/Profildrehen (Vollradius)

Grooving and Profiling (Full radius)



Wendeschneidplatte

Indexable insert

315

mit runder Spanleitstufe
with round chip breaker

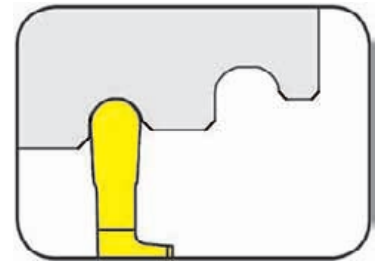

Stechtiefe bis Vollradius	Depth of groove up to Full radius	5 mm 0,5-2 mm
---------------------------	-----------------------------------	------------------

für Klemhalter
for Toolholder

Typ 356
Type 333
357

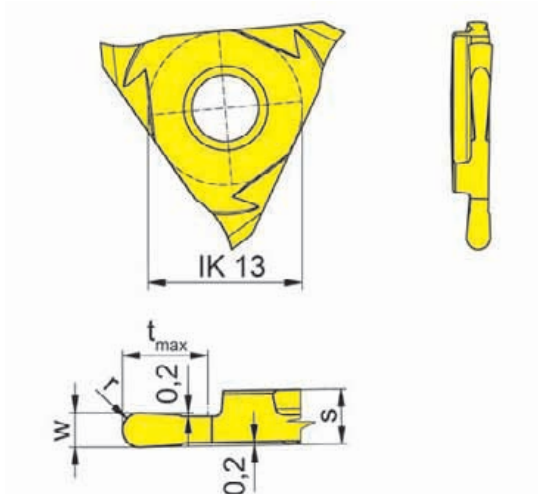

R = rechts wie gezeichnet
R = right hand version shown

L = links spiegelbildlich
L = left hand version

Wechselgenauigkeit
Länge ± 0,02 mm
Indexability length ± 0,02 mm

Bestellnummer Part number	w	t _{max}	r	s	Größe Size	AS45
R/L315.0100.05	1,0	2,5	0,50	3,2	03	▲▲
R/L315.0120.06	1,2	3,0	0,60	3,2	03	▲▲
R/L315.0150.07	1,5	5,0	0,75	3,2	03	▲▲
R/L315.0160.08	1,6	5,0	0,80	3,2	03	▲▲
R/L315.0180.09	1,8	5,0	0,90	3,2	03	▲▲
R/L315.0200.10	2,0	5,0	1,00	3,2	03	▲▲
R/L315.0220.11	2,2	5,0	1,10	3,2	03	▲▲
R/L315.0250.12	2,5	5,0	1,25	3,2	03	▲▲
R/L315.0280.14	2,8	5,0	1,40	3,2	03	▲▲
R/L315.0300.15	3,0	5,0	1,50	3,2	03	▲▲
R/L315.0360.18	3,6	5,0	1,80	5,4	05	△▲
R/L315.0400.20	4,0	5,0	2,00	5,4	05	▲▲

▲ ab Lager / on stock △ 4 Wochen / 4 weeks x auf Anfrage / upon request

● empfohlen / recommended

o bedingt einsetzbar / alternative recommendation

- nicht geeignet / not suitable

■ unbeschichtete HM-Sorten / uncoated grades

■ beschichtete HM-Sorten / coated grades

■ bestückt/Cermet / brazed/Cermet

P	•
M	•
K	•
N	o
S	•
H	-

HM-Sorten
Carbide grades

Ausführung R oder L angeben

State R or L version

Abmessungen in mm

Dimensions in mm

Weitere Radien auf Anfrage

Further radii upon request

Bearbeitungshinweis:

Nutbreiten bis 1,6 mm nur zum Nutenstechdrehen empfohlen

Note:

Width of groove up to 1,6 mm recommend only for grooving

Axialeinstechen

Face Grooving



Wendeschneidplatte

Indexable insert

A315

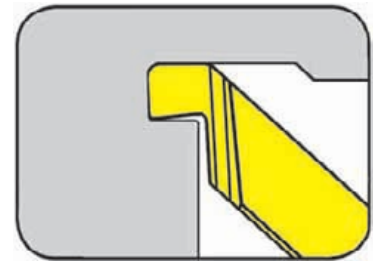

Nutaußen-Ø ab	from outer groove Ø	8 mm
Stechtiefe bis	Depth of groove up to	2 mm
Stechbreite	Width of groove	1,5-2,4 mm

für Klemmhalter
for Toolholder

Typ 356
Type

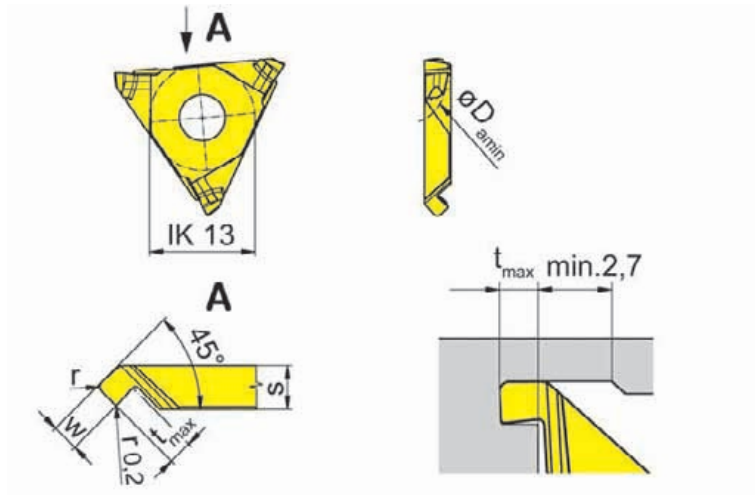

L = links wie gezeichnet
L = left hand version shown

R = rechts spiegelbildlich
R = right hand version

Wechselgenauigkeit
Länge ± 0,02 mm
Indexability length ± 0,02 mm

Bestellnummer Part number	w	r	t _{max}	D _{a min}	s	Größe Size	TH35	TN35
LA315.0815.45.04R	1,5	0,4	1,6	8	3,25	03	▲	▲
RA315.0815.45.04L	1,5	0,4	1,6	8	3,25	03	▲	▲
LA315.1220.45.05R	2,0	0,5	1,8	12	3,25	03	▲	▲
RA315.1220.45.05L	2,0	0,5	1,8	12	3,25	03	▲	▲
LA315.2024.45.06R	2,4	0,6	2,0	20	3,25	03	▲	▲
RA315.2024.45.06L	2,4	0,6	2,0	20	3,25	03	▲	▲

▲ ab Lager / on stock Δ 4 Wochen / 4 weeks x auf Anfrage / upon request

● empfohlen / recommended

o bedingt einsetzbar / alternative recommendation

- nicht geeignet / not suitable

□ unbeschichtete HM-Sorten / uncoated grades

■ beschichtete HM-Sorten / coated grades

■ bestückt/Cermet / brazed/Cermet

Abmessungen in mm

Dimensions in mm

Rechte WSP in linken, linke WSP in rechten Klemmhaltern verwenden.

Use right hand inserts in left hand toolholders and left hand inserts in right hand toolholders

Der Freistich muss VOR der Axialbearbeitung eingebracht werden!

The undercut must be placed BEFORE the axial machining!

Ausführung R oder L angeben

State R or L version

P	•	•
M	•	•
K	•	•
N	•	•
S	•	•
H	-	-

HM-Sorten
Carbide grades

Axialeinstechen

Face Grooving



Wendeschneidplatte

Indexable insert

A315

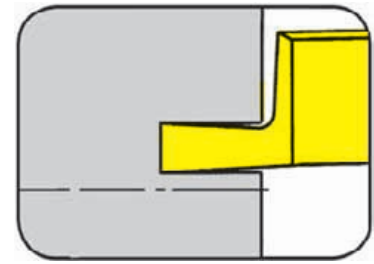

Stechtiefe bis Stechbreite	Depth of groove up to Width of groove	3 mm 1,5-3 mm
-------------------------------	--	------------------

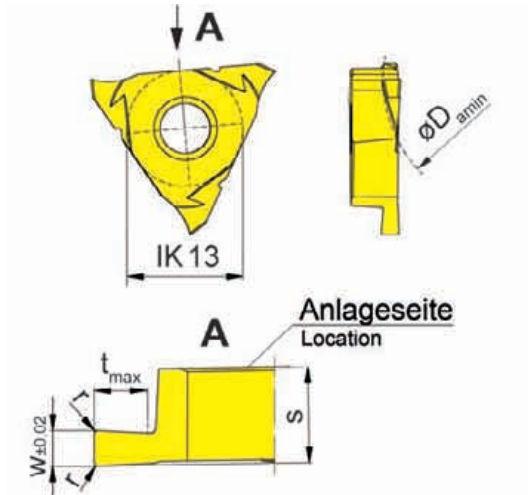

für Klemhalter
for Toolholder

Typ 357
Type 356...03-07

R = rechts wie gezeichnet
R = right hand version shown

L = links spiegelbildlich
L = left hand version

Bestellnummer Part number	w	r	t _{max}	D _{a min}	s	Größe Size	TH35
LA315.2015.02R	1,5	0,2	2	20	5,4	05	▲
RA315.2015.02L	1,5	0,2	2	20	5,4	05	▲
LA315.3020.02R	2,0	0,2	3	30	5,4	05	▲
RA315.3020.02L	2,0	0,2	3	30	5,4	05	▲
LA315.3030.02R	3,0	0,2	3	30	5,4	05	▲
RA315.3030.02L	3,0	0,2	3	30	5,4	05	▲

▲ ab Lager / on stock Δ 4 Wochen / 4 weeks x auf Anfrage / upon request

● empfohlen / recommended

o bedingt einsetzbar / alternative recommendation

- nicht geeignet / not suitable

■ unbeschichtete HM-Sorten / uncoated grades

■ beschichtete HM-Sorten / coated grades

■ bestückt/Cermet / brazed/Cermet

Abmessungen in mm

Dimensions in mm

Ausführung R oder L angeben

State R or L version

P	•
M	•
K	•
N	•
S	•
H	-

HM-Sorten
Carbide grades

Axialeinstechen

Face Grooving



Wendeschneidplatte

Indexable insert

A315

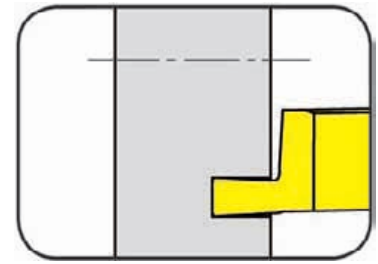

Nutaußen-Ø ab	from outer groove Ø	20 mm
Stechtiefe bis	Depth of groove up to	3 mm
Stechbreite	Width of groove	1,5-3 mm

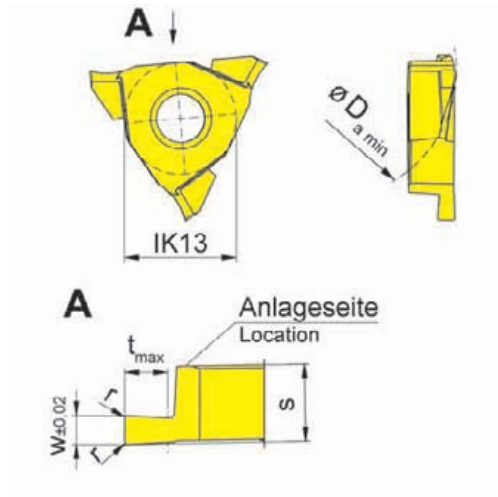

für Klemhalter
for Toolholder

Typ 356
Type 357

Wechselgenauigkeit
Länge ± 0,02 mm
Indexability length ± 0,02 mm

R = rechts wie gezeichnet
R = right hand version shown

Bestellnummer Part number	w	r	t _{max}	D _{a min}	s	Größe Size	TH35
RA315.2015.02R	1,5	0,2	2	20	5,4	05	▲
RA315.3020.02R	2,0	0,2	3	30	5,4	05	▲
RA315.3030.02R	3,0	0,2	3	30	5,4	05	▲

▲ ab Lager / on stock Δ 4 Wochen / 4 weeks x auf Anfrage / upon request

● empfohlen / recommended

o bedingt einsetzbar / alternative recommendation

- nicht geeignet / not suitable

■ unbeschichtete HM-Sorten / uncoated grades

■ beschichtete HM-Sorten / coated grades

■ bestückt/Cermet / brazed/Cermet

Abmessungen in mm

Dimensions in mm

P	•
M	•
K	•
N	•
S	•
H	-

HM-Sorten
Carbide grades

Gewindedrehen (außen) Teilprofil

Threading (external) Partial profile



Wendeschneidplatte

Indexable insert

315

Metrisches ISO-Gewinde
Metric ISO thread

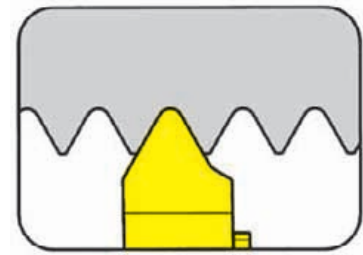

Steigung	Pitch	1 - 6 mm
----------	-------	----------

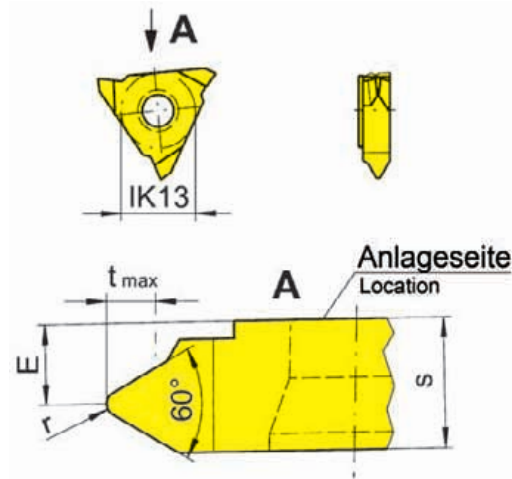

für Klemmhalter
for Toolholder

Typ 356
Type

R = rechts wie gezeichnet
R = right hand version shown

L = links spiegelbildlich
L = left hand version

Bestellnummer Part number	P	P _{max}	E	r	t _{max}	s	Größe Size	TN35
R/L315.0610.01	1,00	1,00	4,50	0,14	0,61	5,45	05	▲/△
R/L315.0712.01	1,25	1,25	4,50	0,15	0,77	5,45	05	▲/△
R/L315.0915.01	1,50	1,50	4,15	0,20	0,92	5,45	05	▲/△
R/L315.1017.01	1,75	1,75	4,15	0,25	1,07	5,45	05	▲/△
R/L315.1220.01	2,00	2,00	4,15	0,25	1,23	5,45	05	▲/△
R/L315.1525.01	2,50	2,50	3,80	0,35	1,53	5,45	05	▲/△
R/L315.1830.01	3,00	3,00	3,60	0,40	1,84	5,45	05	▲/△
R/L315.3060.01	3,00	6,00	3,00	0,40	4,15	6,10	05	▲/△
R/L315.2135.01	3,50	3,50	3,40	0,50	2,15	5,45	05	▲/△

▲ ab Lager / on stock Δ 4 Wochen / 4 weeks x auf Anfrage / upon request

● empfohlen / recommended

o bedingt einsetzbar / alternative recommendation

- nicht geeignet / not suitable

■ unbeschichtete HM-Sorten / uncoated grades

■ beschichtete HM-Sorten / coated grades

■ bestückt/Cermet / brazed/Cermet

P	•
M	•
K	•
N	•
S	•
H	-

Abmessungen in mm

Dimensions in mm

Ausführung R oder L angeben

State R or L version

HM-Sorten

Carbide grades

Keine Unterlegplatte erforderlich. Sämtliche HORN-Gewindeprofile sind mit einem **KEGELMANTEL-FREISCHLIFF** versehen.
No shims necessary. All HORN thread profiles are manufactured with **full ground radial clearance**.

Außenbearbeitung:

Rechte WSP in rechten Klemmhalter 356, linke WSP in linken Klemmhaltern 356 verwenden.

External machining:

Right hand insert in right hand toolholder 356, left hand insert in left hand toolholder 356.

Gewindedrehen (außen) Vollprofil

Threading (external) Full profile



Wendeschneidplatte

Indexable insert

315

Metrisches ISO-Gewinde
Metric ISO thread

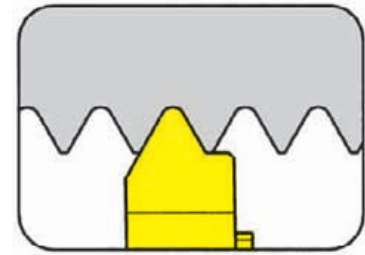

Steigung	Pitch	1-6 mm
----------	-------	--------

für Klemhalter
for Toolholder

Typ 356
Type

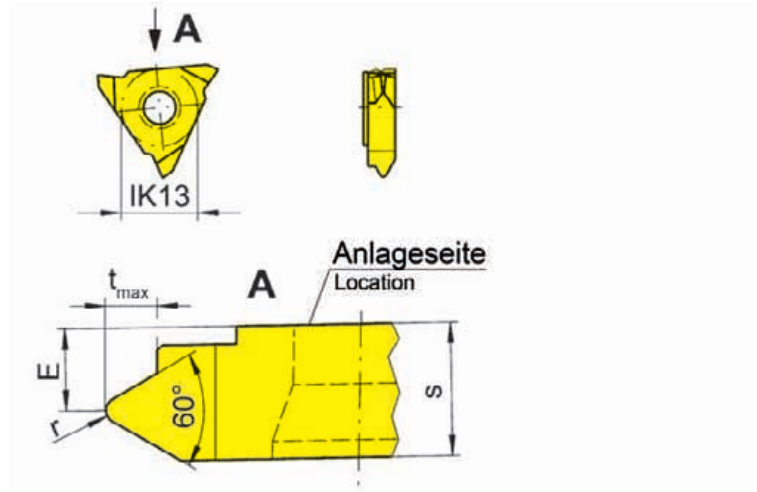

R = rechts wie gezeichnet
R = right hand version shown

L = links spiegelbildlich
L = left hand version

Bestellnummer Part number	P	E	r	t _{max}	s	Größe Size	TN35
R/L315.0610.02	1,00	4,50	0,14	0,61	5,45	05	▲/▲
R/L315.0712.02	1,25	4,50	0,15	0,77	5,45	05	▲/△
R/L315.0915.02	1,50	4,15	0,20	0,92	5,45	05	▲/▲
R/L315.1017.02	1,75	4,15	0,25	1,07	5,45	05	▲/△
R/L315.1220.02	2,00	4,15	0,25	1,23	5,45	05	▲/△
R/L315.1525.02	2,50	3,80	0,35	1,55	5,45	05	▲/△
R/L315.1830.02	3,00	3,60	0,40	1,84	5,45	05	▲/▲
R/L315.2135.02	3,50	3,40	0,50	2,15	5,45	05	▲/△
R/L315.2440.02	4,00	3,30	0,55	2,45	5,45	05	△/△
R/L315.3050.02	5,00	4,00	0,70	3,07	6,50	06/07	▲/△
R/L315.3660.02	6,00	4,10	0,85	3,68	7,00	07	△/△

▲ ab Lager / on stock △ 4 Wochen / 4 weeks x auf Anfrage / upon request

● empfohlen / recommended

o bedingt einsetzbar / alternative recommendation

- nicht geeignet / not suitable

■ unbeschichtete HM-Sorten / uncoated grades

■ beschichtete HM-Sorten / coated grades

■ bestückt/Cermet / brazed/Cermet

P	•
M	•
K	•
N	•
S	•
H	-

Abmessungen in mm

Dimensions in mm

Ausführung R oder L angeben

State R or L version

HM-Sorten

Carbide grades

Keine Unterlegplatte erforderlich. Sämtliche HORN-Gewindeprofile sind mit einem **KEGELMANTEL-FREISCHLIFF** versehen.

No shims necessary. All HORN thread profiles are manufactured with **full ground radial clearance**.

Außenbearbeitung:

Rechte WSP in rechten Klemhalter 356, linke WSP in linken Klemhaltern 356 verwenden.

External machining:

Right hand insert in right hand toolholder 356, left hand insert in left hand toolholder 356.

Gewindedrehen (innen) Teilprofil

Threading (internal) Partial profile



Wendeschneidplatte

Indexable insert

315

Metrisches ISO-Gewinde
Metric ISO thread

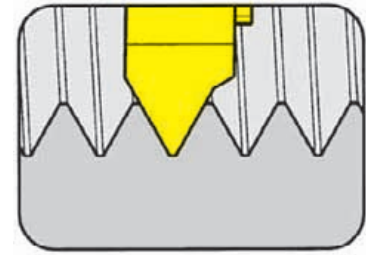

Steigung	Pitch	1-3,5 mm
----------	-------	----------

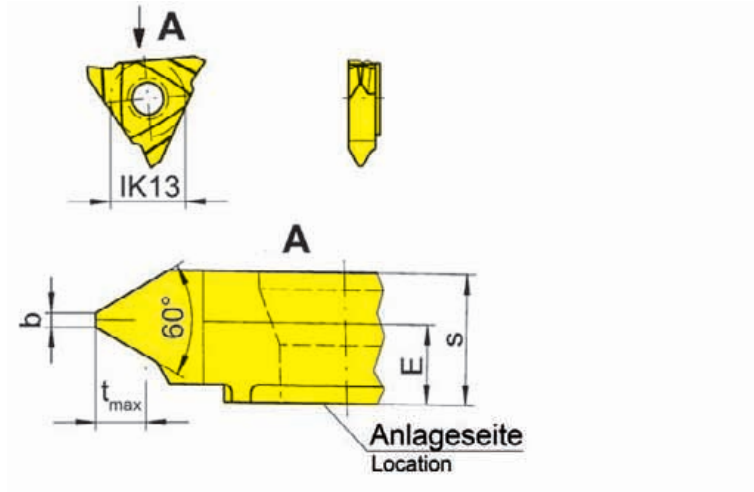

für Klemhalter
for Toolholder

Typ 333
Type 357

R = rechts wie gezeichnet
R = right hand version shown

L = links spiegelbildlich
L = left hand version

Bestellnummer Part number	P	E	t _{max}	b	s	D _{min}	Größe Size	TN35
R/L315.0510.01	1,0	4,85	0,55	0,12	5,45	40	05	ΔΔ
R/L315.0815.01	1,5	4,65	0,81	0,18	5,45	40	05	ΔΔ
R/L315.1020.01	2,0	4,45	1,08	0,25	5,45	40	05	ΔΔ
R/L315.1325.01	2,5	4,25	1,35	0,31	5,45	43	05	ΔΔ
R/L315.1630.01	3,0	4,05	1,62	0,37	5,45	43	05	ΔΔ
R/L315.1835.01	3,5	3,90	1,89	0,43	5,45	43	05	ΔΔ

▲ ab Lager / on stock Δ 4 Wochen / 4 weeks x auf Anfrage / upon request

● empfohlen / recommended

o bedingt einsetzbar / alternative recommendation

- nicht geeignet / not suitable

■ unbeschichtete HM-Sorten / uncoated grades

■ beschichtete HM-Sorten / coated grades

■ bestückt/Cermet / brazed/Cermet

P	•
M	•
K	•
N	•
S	•
H	-

Abmessungen in mm

Dimensions in mm

Ausführung R oder L angeben

State R or L version

HM-Sorten

Carbide grades

Keine Unterlegplatte erforderlich. Sämtliche HORN-Gewindeprofile sind mit einem **KEGELMANTEL-FREISCHLIFF** versehen.

No shims necessary. All HORN thread profiles are manufactured with **full ground radial clearance**.

Innenbearbeitung:

Rechte Gewinde-WSP in rechten Klemmhalter 333/357, linke Gewinde-WSP in linken Klemmhaltern 333/357 verwenden.

Internal machining:

Right hand threading insert in right hand toolholder 333/357, left hand threading insert in left hand toolholder 333/357

Gewindedrehen (innen) Vollprofil

Threading (internal) Full profile



Wendeschneidplatte

Indexable insert

315

Metrisches ISO-Gewinde
Metric ISO thread

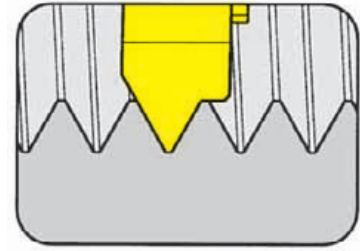

Steigung	Pitch	1-3,5 mm
----------	-------	----------

für Klemmhalter
for Toolholder

Typ 333
Type 357

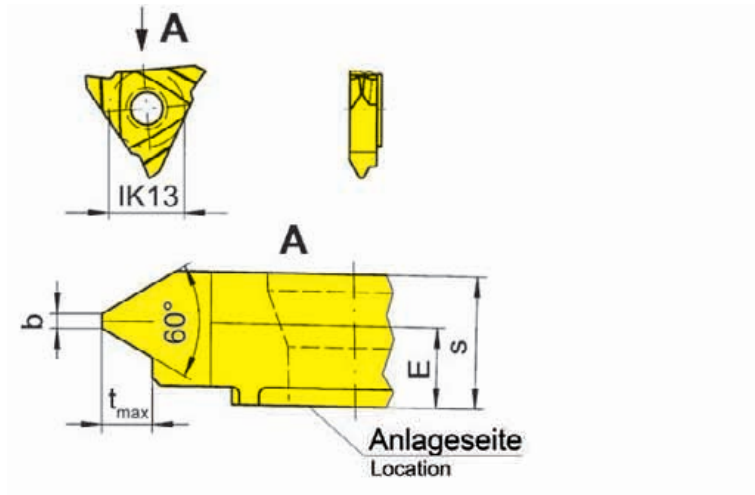

R = rechts wie gezeichnet
R = right hand version shown

L = links spiegelbildlich
L = left hand version

Bestellnummer Part number	P	E	t _{max}	b	s	D _{min}	Größe Size	TN35
R/L315.0510.02	1,0	4,85	0,55	0,12	5,45	40	05	Δ/Δ
R/L315.0815.02	1,5	4,65	0,81	0,18	5,45	40	05	▲/Δ
R/L315.1020.02	2,0	4,45	1,08	0,25	5,45	40	05	▲/Δ
R/L315.1325.02	2,5	4,25	1,35	0,31	5,45	43	05	Δ/Δ
R/L315.1630.02	3,0	4,05	1,62	0,37	5,45	43	05	▲/Δ
R/L315.1835.02	3,5	3,90	1,89	0,43	5,45	43	05	Δ/Δ

▲ ab Lager / on stock Δ 4 Wochen / 4 weeks x auf Anfrage / upon request

● empfohlen / recommended

o bedingt einsetzbar / alternative recommendation

- nicht geeignet / not suitable

■ unbeschichtete HM-Sorten / uncoated grades

■ beschichtete HM-Sorten / coated grades

■ bestückt/Cermet / brazed/Cermet

P	•
M	•
K	•
N	•
S	•
H	-

Abmessungen in mm

Dimensions in mm

Ausführung R oder L angeben

State R or L version

HM-Sorten

Carbide grades

Keine Unterlegplatte erforderlich. Sämtliche HORN-Gewindeprofile sind mit einem **KEGELMANTEL-FREISCHLIFF** versehen.

No shims necessary. All HORN thread profiles are manufactured with **full ground radial clearance**.

Innenbearbeitung:

Rechte Gewinde-WSP in rechten Klemmhalter 333/357, linke Gewinde-WSP in linken Klemmhaltern 333/357 verwenden.

Internal machining:

Right hand threading insert in right hand toolholder 333/357, left hand threading insert in left hand toolholder 333/357

Gewindedrehen (außen) Vollprofil

Threading (external) Full profile



Wendeschneidplatte

Indexable insert

315

Whitworth Rohrgewinde
Whitworth pipe thread

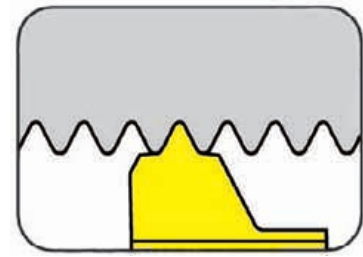

Gang pro Zoll	Threads per inch	11-28
---------------	------------------	-------

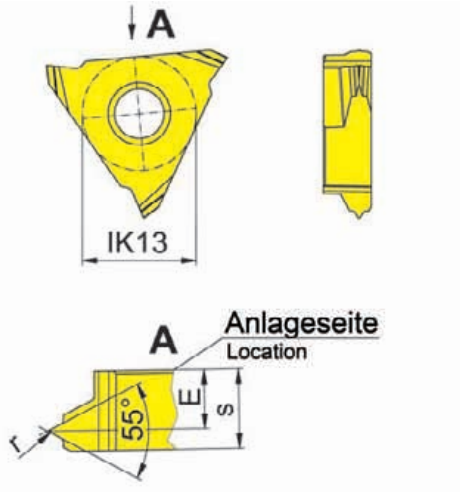

für Klemmhalter
for Toolholder

Typ 356
Type

R = rechts wie gezeichnet
R = right hand version shown

L = links spiegelbildlich
L = left hand version

Bestellnummer Part number	TPI	E	r	s	Größe Size	TH35
R/L315.5528.02	28	4,35	0,11	5,45	05	▲▲
R/L315.5519.02	19	4,05	0,17	5,45	05	▲▲
R/L315.5514.02	14	3,75	0,23	5,45	05	▲▲
R/L315.5511.02	11	3,55	0,30	5,45	05	▲▲

▲ ab Lager / on stock Δ 4 Wochen / 4 weeks x auf Anfrage / upon request

● empfohlen / recommended

o bedingt einsetzbar / alternative recommendation

- nicht geeignet / not suitable

■ unbeschichtete HM-Sorten / uncoated grades

■ beschichtete HM-Sorten / coated grades

■ bestückt/Cermet / brazed/Cermet

P	•
M	•
K	•
N	•
S	•
H	-

Abmessungen in mm

Dimensions in mm

Ausführung R oder L angeben

State R or L version

HM-Sorten

Carbide grades

Keine Unterlegplatte erforderlich. Sämtliche HORN-Gewindeprofile sind mit einem **KEGELMANTEL-FREISCHLIFF** versehen.

No shims necessary. All HORN thread profiles are manufactured with **full ground radial clearance**.

Außenbearbeitung:

Rechte WSP in rechten Klemmhalter 356, linke WSP in linken Klemmhältern 356 verwenden.

External machining:

Right hand insert in right hand toolholder 356, left hand insert in left hand toolholder 356.

Gewindedrehen Vollprofil

Threading Full profile



Wendeschneidplatte

315

Indexable insert

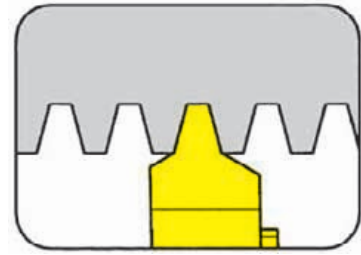

Steigung	Pitch	1,5-6 mm
----------	-------	----------

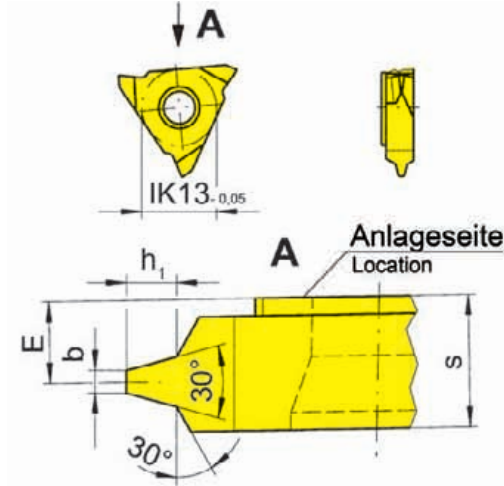

für Klemhalter
for Toolholder

Typ 333
Type 356
357

R = rechts wie gezeichnet
R = right hand version shown

L = links spiegelbildlich
L = left hand version

Metrisches ISO
Trapezgewinde DIN 103
Metric ISO trapezoidal thread
DIN 103

Bestellnummer Part number	P	E	h ₁	b	s	D _{min}	Größe Size	TN35
R/L315.1015.02	1,5	4,5	0,90	0,47	5,45	43	05	▲/△
R/L315.1320.02	2,0	4,3	1,25	0,60	5,45	43	05	▲/△
R/L315.1730.02	3,0	4,0	1,75	0,96	5,45	43	05	▲/▲
R/L315.2240.02	4,0	3,6	2,25	1,33	5,45	43	05	▲/▲
R/L315.2750.02	5,0	3,3	2,75	1,70	5,45	43	05	▲/△
R/L315.3560.02	6,0	3,0	3,50	1,93	5,45	43	05	▲/▲

▲ ab Lager / on stock △ 4 Wochen / 4 weeks x auf Anfrage / upon request

● empfohlen / recommended

o bedingt einsetzbar / alternative recommendation

- nicht geeignet / not suitable

■ unbeschichtete HM-Sorten / uncoated grades

■ beschichtete HM-Sorten / coated grades

■ bestückt/Cermet / brazed/Cermet

P	•
M	•
K	•
N	•
S	•
H	-

Abmessungen in mm

Dimensions in mm

Ausführung R oder L angeben

State R or L version

HM-Sorten

Carbide grades

Keine Unterlegplatte erforderlich. Sämtliche HORN-Gewindeprofile sind mit einem **KEGELMANTEL-FREISCHLIFF** versehen.

No shims necessary. All HORN thread profiles are manufactured with **full ground radial clearance**.

Außenbearbeitung:

Rechte WSP in rechten Klemhalter 356, linke WSP in linken Klemhaltern 356 verwenden.

External machining:

Right hand insert in right hand toolholder 356, left hand insert in left hand toolholder 356.

Innenbearbeitung:

Rechte WSP in linken Klemhalter 333/357, linke WSP in rechten Klemhaltern 333/357 verwenden.

Internal machining:

Right hand insert in left hand toolholder 333/357, left hand insert in right hand toolholder 333/357.

Wendeschneidplatte

Indexable insert

315

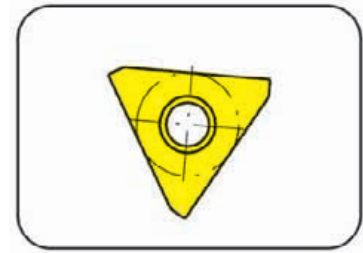

Grundabmessungen Typ 315
Basic sizes type 315

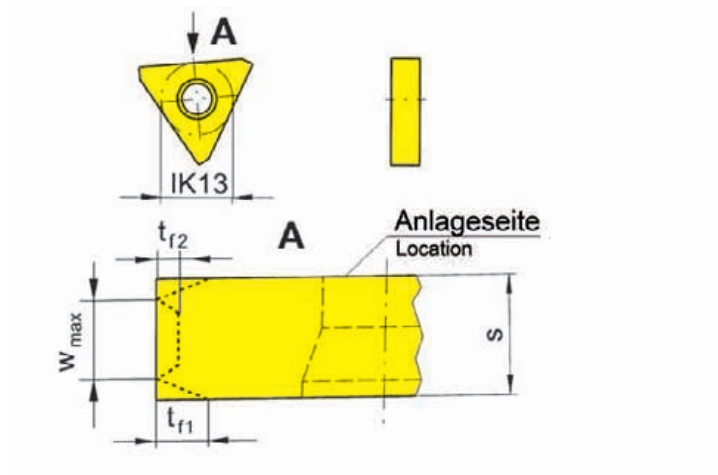

für Klemmhalter
for Toolholder

Typ 356
Type

R = rechts wie gezeichnet
R = right hand version shown

L = links spiegelbildlich
L = left hand version

Bestellnummer Part number	W_{max}	t_{f2}	t_{f1}	s	Größe Size	TN35	TI25	TA45	TA46
R/L315...	3,05	5,0	-	3,25	03				
R/L315...	5,25	5,0	2,0	5,45	05				
R/L315...	5,90	5,0	2,0	6,10	05 / 06				
R/L315...	6,40	5,0	2,0	6,60	06 / 07				
R/L315...	6,90	5,0	2,0	7,10	07				
R/L315...	7,30	5,0	2,0	7,50	07				
R/L315...	8,30	5,0	2,0	8,50	07				
R/L315...	9,30	5,0	2,0	9,50	10				
R/L315...	10,30	5,0	2,0	10,50	10				
R/L315...	13,30	5,0	2,0	13,50	13				
R/L315...	15,30	5,0	2,0	15,50	13				

AUF ANFRAGE
UPON REQUEST

Abmessungen in mm
Dimensions in mm

Ausführung R oder L angeben
State R or L version

P				
M				
K				
N				
S				
H				

HM-Sorten
Carbide grades

Außenbearbeitung:

Rechte WSP in rechten Klemmhalter 356, linke WSP in linken Klemmhaltern 356 verwenden.

External machining:

Right hand insert in right hand toolholder 356, left hand insert in left hand toolholder 356 useable.

Einstechen und Abstechen (außen)

Grooving and Parting off (external)



Wendeschneidplatte

Indexable insert

S315

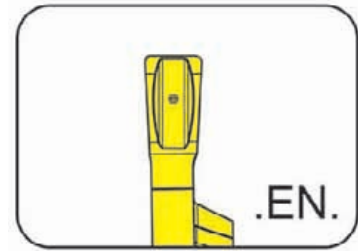

Stechtiefe bis	Depth of groove up to	5,5 mm
Schneidbreite bis	Width of groove up to	2 mm

präzisionsgesintert
precision sintered

für Klemmhalter
for Toolholder

Typ 356...S.4...
Type

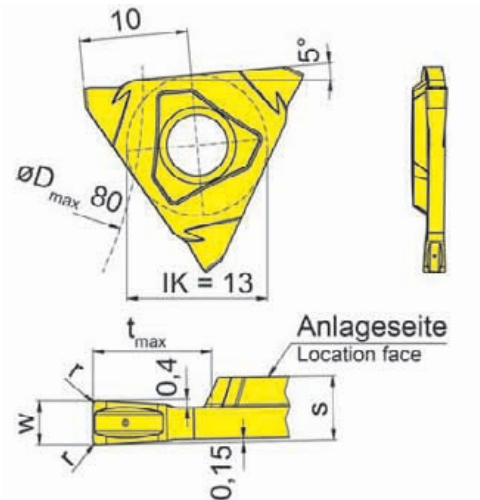

R = rechts wie gezeichnet
R = right hand version shown

L = links spiegelbildlich
L = left hand version

Bestellnummer Part number	w	r	t _{max}	s	Größe Size	EG5G
R/LS315.0200.EN2	2	0,2	5,5	3	03	▲/▲

- ▲ ab Lager / on stock Δ 4 Wochen / 4 weeks x auf Anfrage / upon request
- empfohlen / recommended
- o bedingt einsetzbar / alternative recommendation
- nicht geeignet / not suitable
- unbeschichtete HM-Sorten / uncoated grades
- beschichtete HM-Sorten / coated grades
- bestückt/Cermet / brazed/Cermet

P	•
M	o
K	o
N	-
S	-
H	-

Abmessungen in mm
Dimensions in mm
Ausführung R oder L angeben
State R or L version

HM-Sorten
Carbide grades

Wendeschneidplatte

Indexable insert

S315

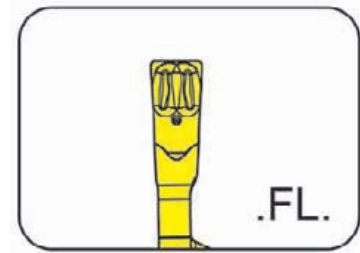

Stechtiefe bis	Depth of groove up to	5,5 mm
Schneidbreite bis	Width of groove up to	1,5 mm

präzisionsgesintert
precision sintered

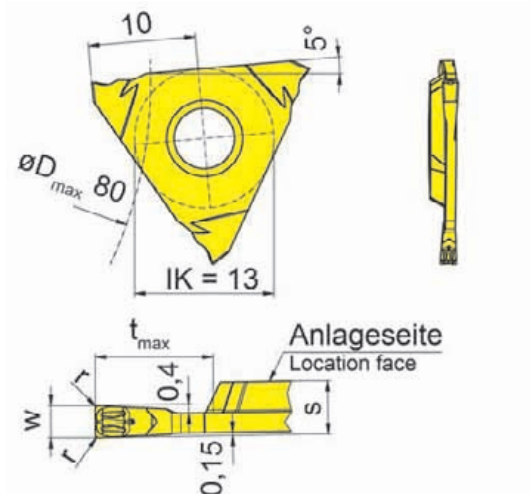

für Klemmhalter
for Toolholder

Typ 356...S.4...
Type

R = rechts wie gezeichnet
R = right hand version shown

L = links spiegelbildlich
L = left hand version

Bestellnummer Part number	w	r	t _{max}	s	Größe Size	EG55
R/LS315.0150.FL15	1,5	0,15	5,5	2,5	03	▲/▲

- ▲ ab Lager / on stock Δ 4 Wochen / 4 weeks x auf Anfrage / upon request
- empfohlen / recommended
- o bedingt einsetzbar / alternative recommendation
- nicht geeignet / not suitable
- unbeschichtete HM-Sorten / uncoated grades
- beschichtete HM-Sorten / coated grades
- bestückt/Cermet / brazed/Cermet

Abmessungen in mm
Dimensions in mm
Ausführung R oder L angeben
State R or L version

P	●
M	○
K	○
N	-
S	-
H	-

HM-Sorten
Carbide grades

NC-Universaldrehplatte

Finishing on NC-Lathes



Wendeschneidplatte

Indexable insert

S315

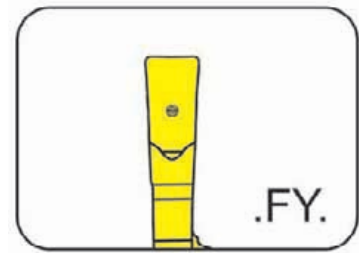

Stechtiefe bis
Stechbreite

Depth of groove up to
Width of groove

5,5 mm
1,5-2 mm

präzisionsgesintert
precision sintered

für Klemmhalter
for Toolholder

Typ 356...S.4...
Type

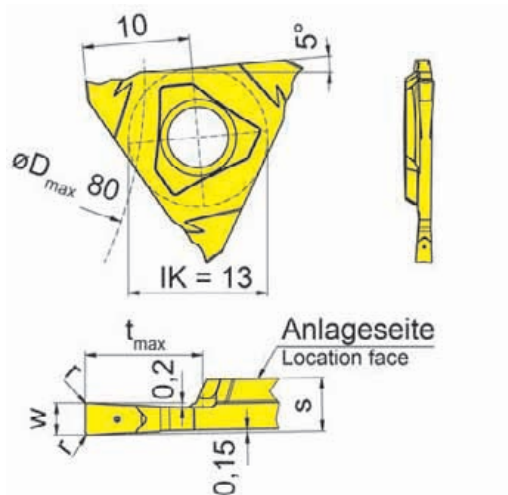

R = rechts wie gezeichnet
R = right hand version shown

L = links spiegelbildlich
L = left hand version

Bestellnummer Part number	w	r	t _{max}	s	Größe Size	EG55
R/LS315.0150.FY15	1,5	0,15	5,5	2,5	03	▲▲
R/LS315.0200.FY2	2,0	0,20	5,5	3,0	03	▲▲

▲ ab Lager / on stock Δ 4 Wochen / 4 weeks x auf Anfrage / upon request

● empfohlen / recommended

o bedingt einsetzbar / alternative recommendation

- nicht geeignet / not suitable

■ unbeschichtete HM-Sorten / uncoated grades

■ beschichtete HM-Sorten / coated grades

■ bestückt/Cermet / brazed/Cermet

Abmessungen in mm

Dimensions in mm

Ausführung R oder L angeben

State R or L version

P	●
M	○
K	○
N	-
S	-
H	-

HM-Sorten
Carbide grades

Wendeschneidplatte

Indexable insert

S315

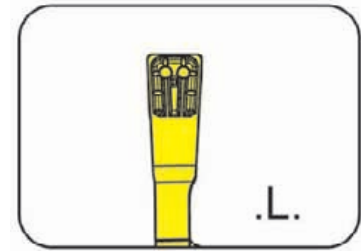

Stechtiefe bis Stechbreite	Depth of groove up to Width of groove	5,5 mm 1,1-2 mm
-------------------------------	--	--------------------

präzisionsgesintert
precision sintered

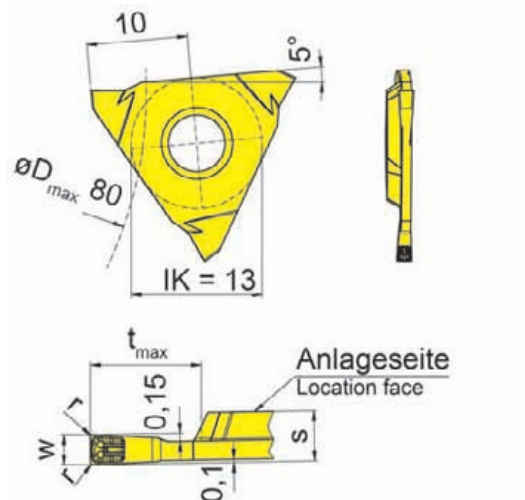

für Klemmhalter
for Toolholder

Typ 356...S.4...
Type

R = rechts wie gezeichnet
R = right hand version shown

L = links spiegelbildlich
L = left hand version

Bestellnummer Part number	w	r	t _{max}	s	Größe Size	EG55
R/LS315.0110.L1	1,1	0,10	5,5	2,5	03	▲▲
R/LS315.0130.L1	1,3	0,10	5,5	2,5	03	▲▲
R/LS315.0150.L15	1,5	0,15	5,5	2,5	03	▲▲
R/LS315.0200.L2	2,0	0,20	5,5	3,0	03	▲▲

▲ ab Lager / on stock Δ 4 Wochen / 4 weeks x auf Anfrage / upon request

● empfohlen / recommended

o bedingt einsetzbar / alternative recommendation

- nicht geeignet / not suitable

■ unbeschichtete HM-Sorten / uncoated grades

■ beschichtete HM-Sorten / coated grades

■ bestückt/Cermet / brazed/Cermet

Abmessungen in mm

Dimensions in mm

Ausführung R oder L angeben

State R or L version

P	●
M	○
K	○
N	-
S	-
H	-

HM-Sorten
Carbide grades



316

P



**Klemmhalter mit
Schneidplatten**

Stechbreite 1,5 - 3 mm

Toolholder with Inserts

Width of groove 1,5 - 3 mm

P

Klemmhalter
Toolholder
H316/HC316

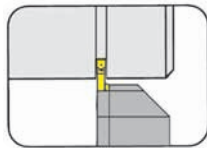

Seite/Page
P3-P4, P10

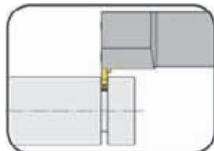

Seite/Page
P5, P11

Kassette
Cassette
NK316

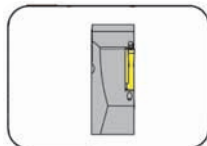

Seite/Page
P6, P12

Wendeschneidplatte
Indexable insert
S316

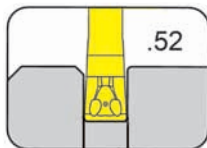

Seite/Page
P7

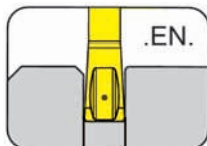

Seite/Page
P8

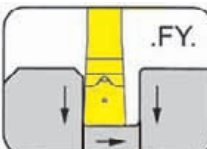

Seite/Page
P9

Einstecken (außen)

Grooving (external)



Klemmhalter

Toolholder

H316

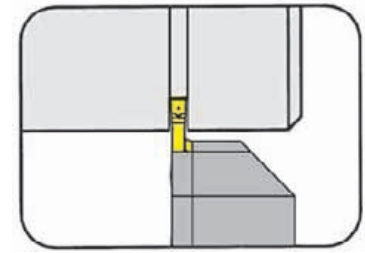

Stechtiefe bis Spannbereich	Depth of groove up to Clamping range	8,0 mm 1,5 - 3,0 mm
--------------------------------	---	------------------------

für Wendeschneidplatte
for Indexable insert

Typ S316
Type

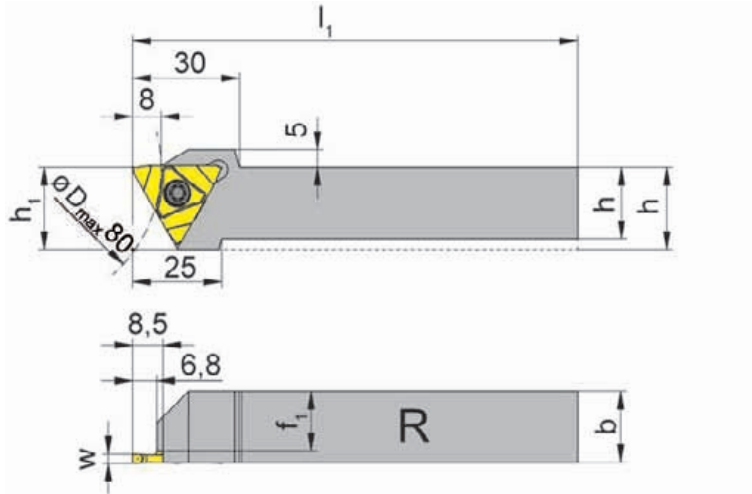

R = rechts wie gezeichnet
R = right hand version shown

L = links spiegelbildlich
L = left hand version

Bestellnummer Part number	h	b	l ₁	h ₁	f ₁	Größe Size
R/LH316.1616.S3.03	16	16	125	23	12,7	03
R/LH316.2020.S3.03	20	20	125	23	16,7	03
R/LH316.2525.S3.03	25	25	150	25	21,7	03
R/LH316.3225.S3.03	32	25	150	32	21,7	03

Ausführung R oder L angeben
State R or L version

w siehe WSP
w see indexable inserts

Abmessungen in mm
Dimensions in mm

Weitere Abmessungen auf Anfrage
Further sizes upon request

Das Anzugsdrehmoment der Schrauben finden Sie in den Technischen Hinweisen.
For torque specification of the screw, please see Technical Instructions.

Ersatzteile

Spare Parts

Klemmhalter Toolholder	Spannschraube Screw	TORX PLUS®-Schlüssel TORX PLUS® Wrench
R/LH316...	5.12T20P	T20PQ

Einstecken (außen)

Grooving (external)



Klemmhalter

Toolholder

H316

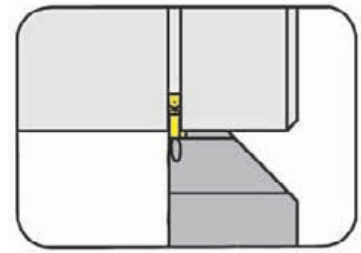

Stechtiefe bis
Spannbereich

Depth of groove up to
Clamping range

8,0 mm
1,5 - 5,0 mm

für Wendeschneidplatte
for Indexable insert

Typ S316
Type

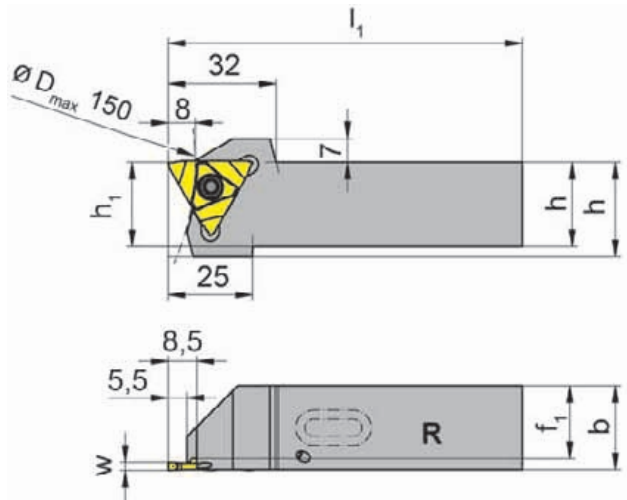

R = rechts wie gezeichnet
R = right hand version shown

L = links spiegelbildlich
L = left hand version

mit integrierter innerer
Kühlmittelzufuhr
with integrated through
coolant supply

Bestellnummer Part number	h	b	l ₁	h ₁	f ₁	Größe Size
R/LH316.2020.S3.03.IK	20	20	90	28	16,7	03
R/LH316.2525.S3.03.IK	25	25	105	28	21,7	03
R/LH316.2020.S5.05.IK	20	20	90	28	14,8	05
R/LH316.2525.S5.05.IK	25	25	105	28	19,8	05

Ausführung R oder L angeben
State R or L version

w siehe WSP
w see indexable inserts

Abmessungen in mm
Dimensions in mm

Weitere Abmessungen auf Anfrage
Further sizes upon request

Das Anzugsdrehmoment der Schrauben finden Sie in den Technischen Hinweisen.
For torque specification of the screw, please see Technical Instructions.

Ersatzteile

Spare Parts

Klemmhalter Toolholder	Spannschraube Screw	TORX PLUS®-Schlüssel TORX PLUS® Wrench
R/LH316...	5.12T20P	T20PQ

Einstechen/Gewindedrehen (außen)

Grooving and Threading (external)



Klemmhalter

Toolholder

HC316

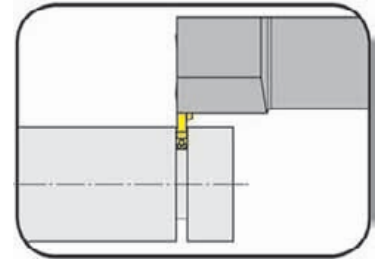

Stechtiefe bis Stechbreite	Depth of groove up to Width of groove	8,0 mm 1,5 - 3,0 mm
-------------------------------	--	------------------------

für Wendeschneidplatte
for Indexable insert

Typ S316
Type

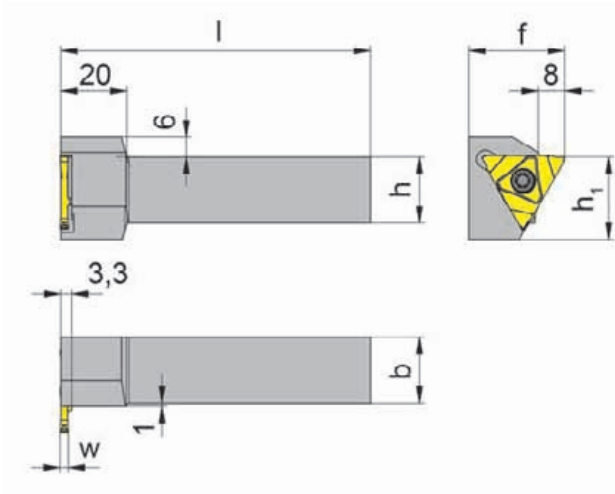

R = rechts wie gezeichnet
R = right hand version shown

L = links spiegelbildlich
L = left hand version

Bestellnummer Part number	h	b	h ₁	f	l	Größe Size
R/LHC316.1616.S3.03	16	16	25	29	125	03
R/LHC316.2020.S3.03	20	20	25	29	125	03
R/LHC316.2525.S3.03	25	25	25	34	150	03
R/LHC316.3225.S3.03	32	25	32	34	150	03

Ausführung R oder L angeben
State R or L version

w siehe WSP
w see indexable inserts

Abmessungen in mm
Dimensions in mm

Weitere Abmessungen auf Anfrage
Further sizes upon request

Das Anzugsdrehmoment der Schrauben finden Sie in den Technischen Hinweisen.
For torque specification of the screw, please see Technical Instructions.

Ersatzteile

Spare Parts

Klemmhalter Toolholder	Spannschraube Screw	TORX PLUS®-Schlüssel TORX PLUS® Wrench
R/LHC316...	5.12T20P	T20PQ

Einstecken (außen)

Grooving (external)



Kassette

Cassette

NK316

mit innerer Kühlmittelzufuhr
with through coolant supply

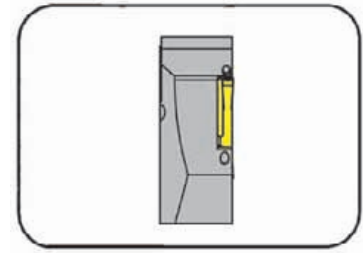

Stechtiefe bis Depth of groove up to 8 mm

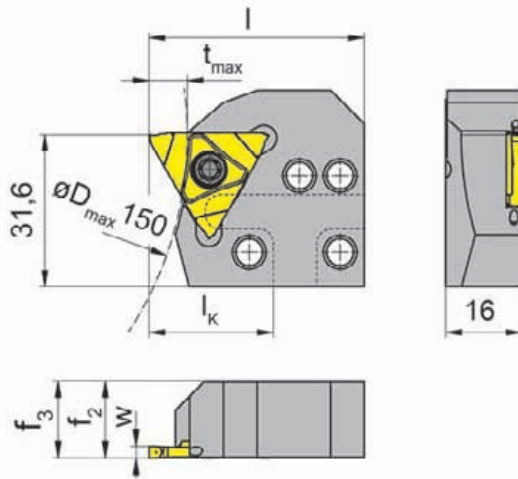

für Wendeschneidplatte
for Indexable insert

Typ S316
Type

R = rechts wie gezeichnet
R = right hand version shown

L = links spiegelbildlich
L = left hand version

Bestellnummer Part number	l	t _{max}	f ₂	f ₃	Größe Size	l _k
R/LNK316.0220.S3.4.03.IK	45	8	16,2	f ₃ =f ₂	03	26

Ausführung R oder L angeben
State R or L version

w siehe WSP
w see indexable inserts

Abmessungen in mm
Dimensions in mm

Bestellhinweis:

Weitere Abmessungen auf Anfrage

Ordering note:

Further sizes upon request

Befestigungsschrauben der Kassetten gehören zum Lieferumfang des Grundhalters.
The fastening screw is combined with the basic toolholder - no separate order required.

Das Anzugsdrehmoment der Schrauben finden Sie in den Technischen Hinweisen.
For torque specification of the screw, please see Technical Instructions.

Ersatzteile

Spare Parts

Kassette Cassette	Spannschraube Screw	TORX PLUS®-Schlüssel TORX PLUS® Wrench
R/LNK316.0220.S3.4.03.IK	5.12T20P	T20PQ

Wendeschneidplatte

Indexable insert

S316

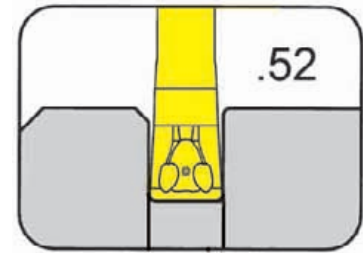

Stechtiefe bis Stechbreite	Depth of groove up to Width of groove	8 mm 2-3 mm
-------------------------------	--	----------------

präzisionsgesintert
precision sintered

für Klemmhalter
for Toolholder

Typ H316...S3...
Type HC316...S3...
NK316...S3...

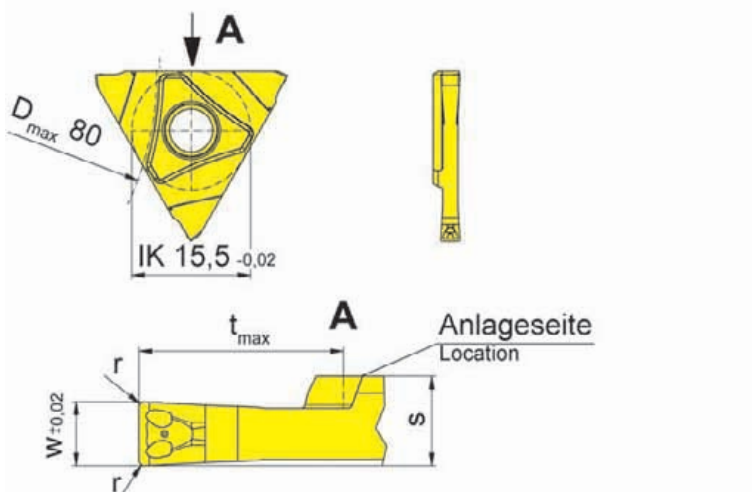

R = rechts wie gezeichnet
R = right hand version shown

L = links spiegelbildlich
L = left hand version

Wechselgenauigkeit
Länge ± 0,02 mm
Indexability length ± 0,02 mm

Bestellnummer Part number	w	r	t _{max}	s	Größe Size	AS45
R/LS316.0200.52	2,0	0,2	8	3,5	03	▲▲
R/LS316.0250.52	2,5	0,2	8	3,5	03	▲▲
R/LS316.0300.52	3,0	0,2	8	3,5	03	▲▲

▲ ab Lager / on stock Δ 4 Wochen / 4 weeks x auf Anfrage / upon request

● empfohlen / recommended

o bedingt einsetzbar / alternative recommendation

- nicht geeignet / not suitable

■ unbeschichtete HM-Sorten / uncoated grades

■ beschichtete HM-Sorten / coated grades

■ bestückt/Cermet / brazed/Cermet

Abmessungen in mm

Dimensions in mm

Ausführung R oder L angeben

State R or L version

HM-Sorten

Carbide grades

P	•
M	•
K	•
N	o
S	•
H	-

Außenbearbeitung:

Rechte WSP in rechten, linke WSP in linken Klemmhaltern verwenden.

External machining:

Use right hand inserts in right hand toolholders and left hand inserts in left hand toolholders

Abstechen

Parting Off



Wendeschneidplatte

Indexable insert

S316

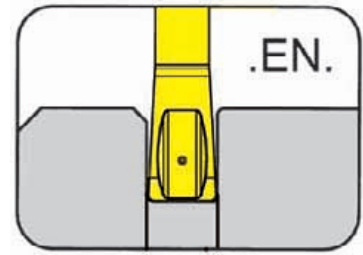

Stechtiefe bis Stechbreite	Depth of groove up to Width of groove	8 mm 2-3 mm
-------------------------------	--	----------------

präzisionsgesintert
precision sintered

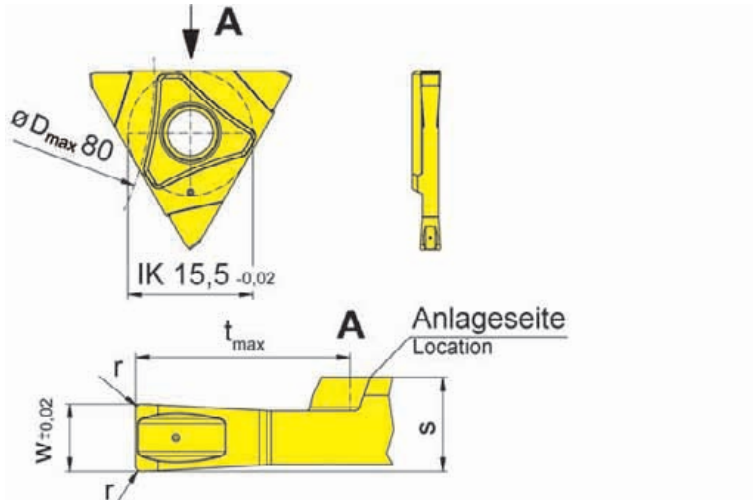

R = rechts wie gezeichnet
R = right hand version shown

L = links spiegelbildlich
L = left hand version

für Klemmhalter
for Toolholder

Typ H316...S3...
Type HC316...S3...
NK316...S3...

Wechselgenauigkeit
Länge $\pm 0,02$ mm
Indexability length $\pm 0,02$ mm

Bestellnummer Part number	w	r	t _{max}	s	Größe Size	AS6G
R/LS316.0200.EN2	2,0	0,2	8	3,5	03	▲▲
R/LS316.0250.EN2	2,5	0,2	8	3,5	03	▲▲
R/LS316.0300.EN2	3,0	0,2	8	3,5	03	▲▲

▲ ab Lager / on stock Δ 4 Wochen / 4 weeks x auf Anfrage / upon request

● empfohlen / recommended

o bedingt einsetzbar / alternative recommendation

- nicht geeignet / not suitable

■ unbeschichtete HM-Sorten / uncoated grades

■ beschichtete HM-Sorten / coated grades

■ bestückt/Cermet / brazed/Cermet

Abmessungen in mm

Dimensions in mm

Ausführung R oder L angeben

State R or L version

HM-Sorten

Carbide grades

Außenbearbeitung:

Rechte WSP in rechten, linke WSP in linken Klemmhaltern verwenden.

External machining:

Use right hand inserts in right hand toolholders and left hand inserts in left hand toolholders

P	•
M	•
K	•
N	•
S	•
H	-

Wendeschneidplatte

Indexable insert

S316

Stechtiefe bis Stechbreite	Depth of groove up to Width of groove	8 mm 1,5-3 mm
-------------------------------	--	------------------

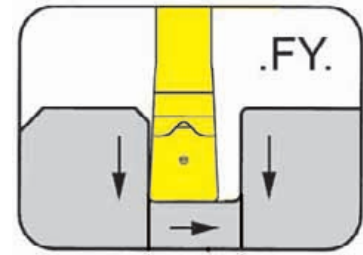

präzisionsgesintert
precision sintered

für Klemmhalter
for Toolholder

Typ H316...S3...
Type HC316...S3...
NK316...S3...

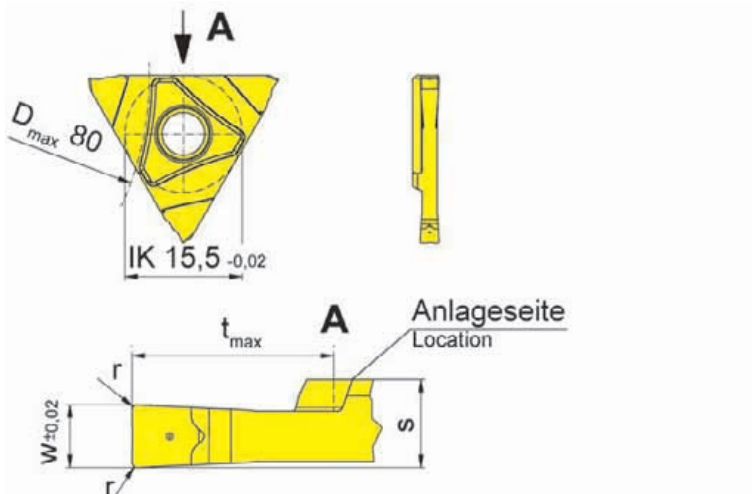

R = rechts wie gezeichnet
R = right hand version shown

L = links spiegelbildlich
L = left hand version

Wechselgenauigkeit
Länge ± 0,02 mm
Indexability length ± 0,02 mm

Bestellnummer Part number	w	r	t _{max}	s	Größe Size	T125
R/LS316.0150.FY1	1,5	0,1	8	3,3	03	▲▲
R/LS316.0200.FY2	2,0	0,2	8	3,5	03	▲▲
R/LS316.0250.FY2	2,5	0,2	8	3,5	03	▲▲
R/LS316.0300.FY2	3,0	0,2	8	3,5	03	▲▲

▲ ab Lager / on stock Δ 4 Wochen / 4 weeks x auf Anfrage / upon request

● empfohlen / recommended

o bedingt einsetzbar / alternative recommendation

- nicht geeignet / not suitable

■ unbeschichtete HM-Sorten / uncoated grades

■ beschichtete HM-Sorten / coated grades

■ bestückt/Cermet / brazed/Cermet

Abmessungen in mm

Dimensions in mm

Ausführung R oder L angeben

State R or L version

HM-Sorten
Carbide grades

P	•
M	•
K	•
N	•
S	•
H	-

Außenbearbeitung:

Rechte WSP in rechten, linke WSP in linken Klemmhaltern verwenden.

External machining:

Use right hand inserts in right hand toolholders and left hand inserts in left hand toolholders



Einstecken (außen)

Grooving (external)



Klemmhalter

Toolholder

H316

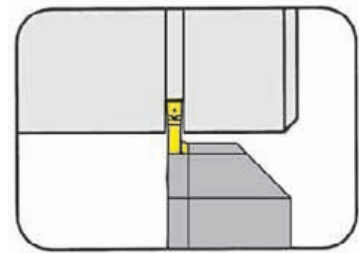

Stechtiefe bis
Spannbereich

Depth of groove up to
Clamping range

8,0 mm
1,5 - 3,0 mm

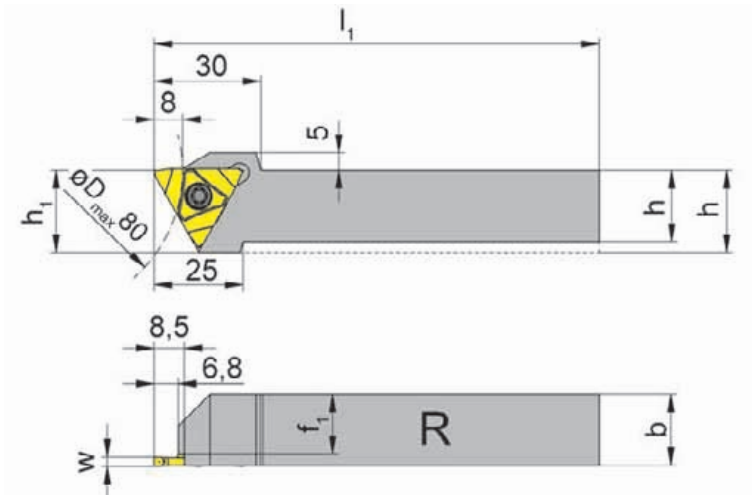

R = rechts wie gezeichnet
R = right hand version shown

L = links spiegelbildlich
L = left hand version

für Wendeschneidplatte
for Indexable insert

Typ 316
Type auf Anfrage
upon request

nur für umfangs-
geschliffene Form-WSP
only for periferal grounded
profiled inserts

Bestellnummer Part number	h	b	l ₁	h ₁	f ₁	Größe Size
R/LH316.1616.03	16	16	125	23	12,7	03
R/LH316.2020.03	20	20	125	23	16,7	03
R/LH316.2525.03	25	25	150	25	21,7	03
R/LH316.3225.03	32	25	150	32	21,7	03

Ausführung R oder L angeben
State R or L version

w siehe WSP
w see indexable inserts

Abmessungen in mm
Dimensions in mm

Weitere Abmessungen auf Anfrage
Further sizes upon request

Das Anzugsdrehmoment der Schrauben finden Sie in den Technischen Hinweisen.
For torque specification of the screw, please see Technical Instructions.

Ersatzteile

Spare Parts

Klemmhalter Toolholder	Spannschraube Screw	TORX PLUS®-Schlüssel TORX PLUS® Wrench
R/LH316...	5.12T20P	T20PQ

Einstecken/Gewindedrehen (außen)

Grooving and Threading (external)



Klemmhalter

Toolholder

HC316

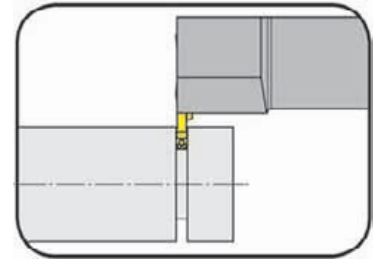

Stechtiefe bis Stechbreite	Depth of groove up to Width of groove	8,0 mm 1,5 - 3,0 mm
-------------------------------	--	------------------------

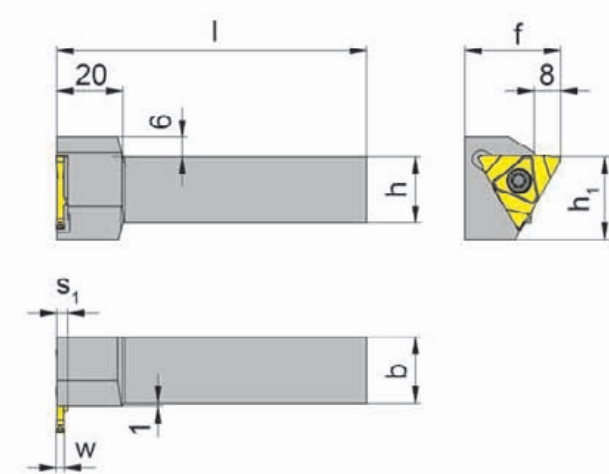

für Wendeschneidplatte
for Indexable insert

Typ 316
Type auf Anfrage
upon request

nur für umfangs-
geschliffene Form-WSP
only for periferal grounded
profiled inserts

R = rechts wie gezeichnet
R = right hand version shown

L = links spiegelbildlich
L = left hand version

Bestellnummer Part number	h	b	h ₁	f	s ₁	l	Größe Size
R/LHC316.1616.03	16	16	25	29	3,3	125	03
R/LHC316.2020.03	20	20	25	29	3,3	125	03
R/LHC316.2525.03	25	25	25	34	3,3	150	03
R/LHC316.3225.03	32	25	32	34	3,3	150	03
R/LHC316.2020.05	20	20	25	29	5,2	125	05
R/LHC316.2525.05	25	25	25	34	5,2	150	05
R/LHC316.3225.05	32	25	32	34	5,2	150	05

Ausführung R oder L angeben
State R or L version

w siehe WSP
w see indexable inserts

Abmessungen in mm
Dimensions in mm

Weitere Abmessungen auf Anfrage
Further sizes upon request

Bestellhinweis:

Rechte WSP in rechten, linke WSP in linken Klemmhaltern verwenden.

Ordering note:

Use right hand inserts in right hand toolholders and left hand inserts in left hand toolholders

Das Anzugsdrehmoment der Schrauben finden Sie in den Technischen Hinweisen.

For torque specification of the screw, please see Technical Instructions.

Ersatzteile

Spare Parts

Klemmhalter Toolholder	Spannschraube Screw	TORX PLUS®-Schlüssel TORX PLUS® Wrench
R/LHC316.1616.03		
R/LHC316...	5.12T20P	T20PQ

Einstecken (außen)

Grooving (external)



Kassette

Cassette

NK316

mit innerer Kühlmittelzufuhr
with through coolant supply

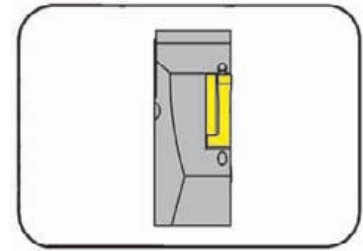

Stechtiefe bis Depth of groove up to 8 mm

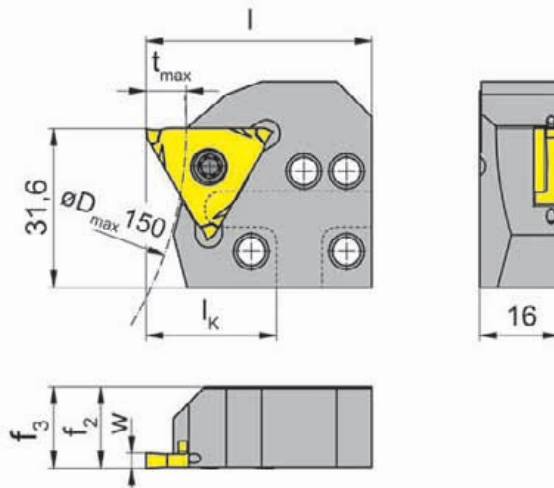

R = rechts wie gezeichnet
R = right hand version shown

L = links spiegelbildlich
L = left hand version

für Wendeschneidplatte
for Indexable insert

Typ 316
Type auf Anfrage
 upon request

Bestellnummer Part number	l	t _{max}	f ₂	f ₃	l _k	Größe Size
R/LNK316.0220.4.03.IK	45	8	16,2	f ₃ =f ₂	26	03
R/LNK316.0220.4.05.IK	45	8	16,2	f ₃ =f ₂	26	05

Ausführung R oder L angeben
State R or L version

w siehe WSP
w see indexable inserts

Abmessungen in mm
Dimensions in mm

Weitere Abmessungen auf Anfrage
Further sizes upon request

Further sizes upon request

Bestellhinweis:

Befestigungsschrauben der Kassetten gehören zum Lieferumfang des Grundhalters.

Ordering note:

The fastening screw is combined with the basic toolholder - no separate order required.

Das Anzugsdrehmoment der Schrauben finden Sie in den Technischen Hinweisen.

For torque specification of the screw, please see Technical Instructions.

Ersatzteile

Spare Parts

Kassette Cassette	Spannschraube Screw	TORX PLUS®-Schlüssel TORX PLUS® Wrench
R/LNK316...	5.12T20P	T20PQ

64T



**Klemmhalter mit
Schneidplatten**

Stechbreite 0,5 - 3,15 mm

**Toolholder with
Inserts**

Width of groove 0,5 - 3,15 mm

Einstechen und Abstechen

Grooving and Parting Off

Klemmhalter
Toolholder
H64T

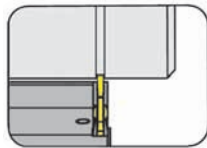

Seite/Page
Q3-Q4

Wendeschneidplatte
Indexable insert
S64T

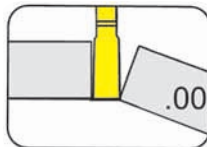

Seite/Page
Q5

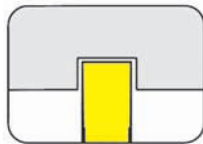

Seite/Page
Q6

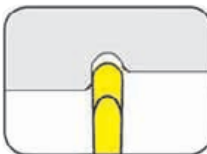

Seite/Page
Q7

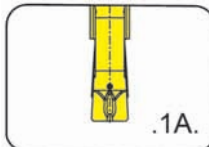

Seite/Page
Q8

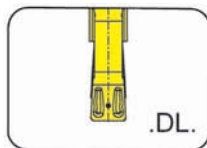

Seite/Page
Q9

Q

Einstechen und Abstechen

Grooving and Parting Off



Klemmhalter

Toolholder

H64T

mit innerer Kühlmittelzufuhr
with through coolant supply

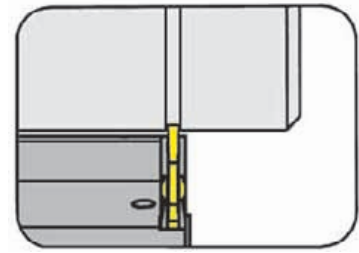

Stechtiefe bis	Depth of groove up to	5,5 mm
----------------	-----------------------	--------

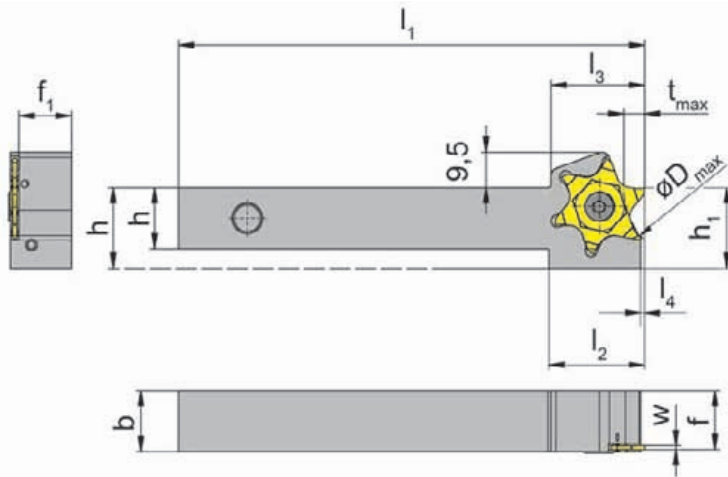

für Wendeschneidplatte
for Indexable insert

Typ S64T
Type

Ein- und Abstechen von Wellen
Grooving and parting off

D _{max}	t _{max}
40	5,5
45	5,0
50	4,5
55	4,0
65	3,5
70	3,5
80	3,0
100	2,5

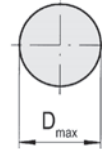

L = links wie gezeichnet
L = left hand version shown

R = rechts spiegelbildlich
R = right hand version

Bestellnummer Part number	h	b	l ₁	l ₂	l ₃	h ₁	f ₁	f	l ₄	Kühlmittelanschluss Coolant supply	Größe Size
R/LH64T.1212.6.10.IK	12	12	125	25	24,5	19	9,8	f ₁ +w+a ₁	1	G1/8	01
R/LH64T.1212.6.20.IK	12	12	125	25	24,5	19	9,3	f ₁ +w+a ₁	1	G1/8	02
R/LH64T.1616.4.10.IK	16	16	125	25	24,5	21	13,8	f ₁ +w+a ₁	1	VDI	01
R/LH64T.1616.4.20.IK	16	16	125	25	24,5	21	13,3	f ₁ +w+a ₁	1	VDI	02
R/LH64T.1616.6.10.IK	16	16	125	25	24,5	21	13,8	f ₁ +w+a ₁	1	G1/8	01
R/LH64T.1616.6.20.IK	16	16	125	25	24,5	21	13,3	f ₁ +w+a ₁	1	G1/8	02
R/LH64T.2020.4.10.IK	20	20	125	25	24,5	25	17,8	f ₁ +w+a ₁	1	VDI	01
R/LH64T.2020.4.20.IK	20	20	125	25	24,5	25	17,3	f ₁ +w+a ₁	1	VDI	02
R/LH64T.2020.6.10.IK	20	20	125	25	24,5	25	17,8	f ₁ +w+a ₁	1	G1/8	01
R/LH64T.2020.6.20.IK	20	20	125	25	24,5	25	17,3	f ₁ +w+a ₁	1	G1/8	02
R/LH64T.2525.4.10.IK	25	25	125	25	24,5	30	22,8	f ₁ +w+a ₁	1	VDI	01
R/LH64T.2525.4.20.IK	25	25	125	25	24,5	30	22,3	f ₁ +w+a ₁	1	VDI	02
R/LH64T.2525.6.10.IK	25	25	125	25	24,5	25	22,8	f ₁ +w+a ₁	1	G1/8	01
R/LH64T.2525.6.20.IK	25	25	125	25	24,5	25	22,3	f ₁ +w+a ₁	1	G1/8	02

Ausführung R oder L angeben
State R or L version

w siehe WSP
w see indexable inserts

Abmessungen in mm
Dimensions in mm

Das Anzugsdrehmoment der Schrauben finden Sie in den Technischen Hinweisen.
For torque specification of the screw, please see Technical Instructions.

Ersatzteile

Spare Parts

Klemmhalter Toolholder	Kühlmittelanschluss Coolant supply	Spannschraube Screw	TORX PLUS®-Schlüssel TORX PLUS® Wrench	Dichtstopfen Sealing plug
R/LH64T.1212.6...	004.00.61	030.4010 T15P	T15PQ	
R/LH64T...	004.00.16	030.4010 T15P	T15PQ	004.00.26

Einstechen und Abstechen

Grooving and Parting Off



Klemmhalter

Toolholder

H64T

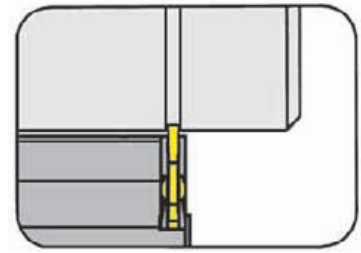

Stechtiefe bis	Depth of groove up to	5,5 mm
----------------	-----------------------	--------

Q

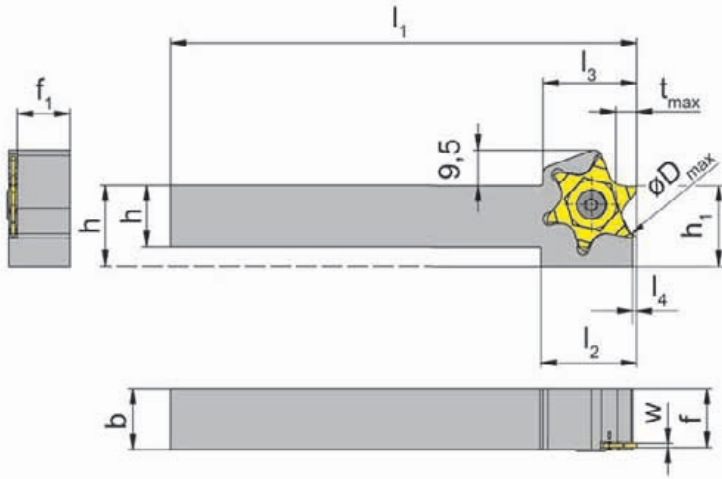

für Wendeschneidplatte
for Indexable insert

Typ S64T
Type

Ein- und Abstechen von Wellen
Grooving and parting off

D _{max}	t _{max}
40	5,5
45	5,0
50	4,5
55	4,0
65	3,5
70	3,5
80	3,0
100	2,5

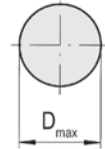

L = links wie gezeichnet
L = left hand version shown

R = rechts spiegelbildlich
R = right hand version

Bestellnummer Part number	h	b	l ₁	l ₂	l ₃	h ₁	f ₁	f	l ₄	Größe Size
R/LH64T.1212.10	12	12	125	25	25,4	19	9,8	f ₁ +w+a ₁	1	01
R/LH64T.1212.20	12	12	125	25	25,4	19	9,3	f ₁ +w+a ₁	1	02
R/LH64T.1616.10	16	16	125	25	25,4	21	13,8	f ₁ +w+a ₁	1	01
R/LH64T.1616.20	16	16	125	25	25,4	21	13,3	f ₁ +w+a ₁	1	02
R/LH64T.2020.10	20	20	125	25	25,4	25	17,8	f ₁ +w+a ₁	1	01
R/LH64T.2020.20	20	20	125	25	25,4	25	17,3	f ₁ +w+a ₁	1	02
R/LH64T.2525.10	25	25	125	-	25,4	25	22,8	f ₁ +w+a ₁	1	01
R/LH64T.2525.20	25	25	125	-	25,4	25	22,3	f ₁ +w+a ₁	1	02

Ausführung R oder L angeben
State R or L version

w siehe WSP
w see indexable inserts

Abmessungen in mm
Dimensions in mm

Das Anzugsdrehmoment der Schrauben finden Sie in den Technischen Hinweisen.
For torque specification of the screw, please see Technical Instructions.

Ersatzteile

Spare Parts

Klemmhalter Toolholder	Spannschraube Screw	TORX PLUS®-Schlüssel TORX PLUS® Wrench
R/LH64T...	030.4010 T15P	T15PQ

Einstechen und Abstechen

Grooving and Parting Off



Wendeschneidplatte

Indexable insert

S64T

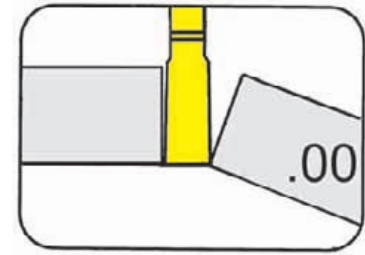

Stechbreite	Width of groove	1-1,5 mm
-------------	-----------------	----------

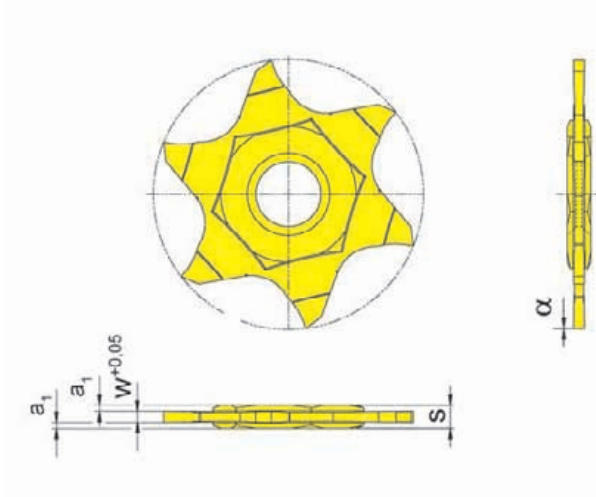

für Klemmhalter
for Toolholder

Typ H64T
Type

Bestellnummer Part number	w	a ₁	s	α	Größe Size	EG55
S64T.0010.00	1,0	0,58	2,2	0°	01	▲
S64T.0015.00	1,5	0,34	2,2	0°	01	▲

▲ ab Lager / on stock Δ 4 Wochen / 4 weeks x auf Anfrage / upon request

● empfohlen / recommended

o bedingt einsetzbar / alternative recommendation

- nicht geeignet / not suitable

■ unbeschichtete HM-Sorten / uncoated grades

■ beschichtete HM-Sorten / coated grades

■ bestückt/Cermet / brazed/Cermet

Abmessungen in mm

Dimensions in mm

Wendeschneidplatten sind in rechten und linken Klemmhaltern verwendbar.

Indexable inserts can be used in right and left hand toolholders.

P	●
M	○
K	○
N	-
S	-
H	-

HM-Sorten
Carbide grades



Einstechen und Abstechen

Grooving and Parting Off



Wendeschneidplatte

Indexable insert

S64T

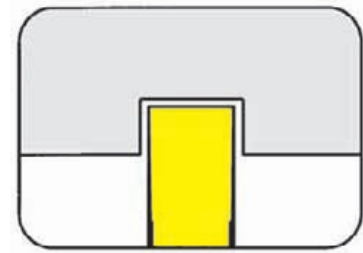

Seegerringnuten
Nutnennbreite Nw

Circlip grooves
Width of circlip Nw

DIN471/472
0,5-3,15 mm

Q

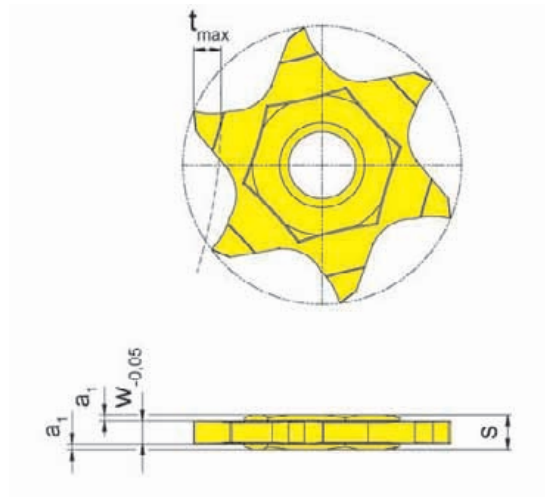

für Klemmhalter
for Toolholder

Typ H64T
Type

Bestellnummer Part number	w	Nw	t _{max}	a ₁	s	Größe Size	EG55
S64T.0050.00	0,57	0,50	0,7	0,83	2,2	01	▲
S64T.0060.00	0,67	0,60	0,8	0,78	2,2	01	▲
S64T.0070.00	0,77	0,70	1,1	0,73	2,2	01	▲
S64T.0080.00	0,87	0,80	1,2	0,68	2,2	01	▲
S64T.0090.00	0,97	0,90	1,4	0,63	2,2	01	▲
S64T.0100.00	1,07	1,00	1,6	0,58	2,2	01	▲
S64T.0110.00	1,24	1,10	1,6	0,49	2,2	01	▲
S64T.0130.00	1,44	1,30	2,0	0,39	2,2	01	▲
S64T.0160.00	1,74	1,60	3,5	0,24	2,2	01	▲
S64T.0185.00	1,99	1,85	3,5	0,12	2,2	01	▲
S64T.0215.00	2,29	2,15	3,5	0,07	2,4	01	▲
S64T.0265.00	2,79	2,65	3,5	0,07	2,9	02	▲
S64T.0315.00	3,29	3,15	3,5	0,07	3,4	02	▲

▲ ab Lager / on stock Δ 4 Wochen / 4 weeks x auf Anfrage / upon request

● empfohlen / recommended

o bedingt einsetzbar / alternative recommendation

- nicht geeignet / not suitable

■ unbeschichtete HM-Sorten / uncoated grades

■ beschichtete HM-Sorten / coated grades

■ bestückt/Cermet / brazed/Cermet

Abmessungen in mm

Dimensions in mm

Wendeschneidplatten sind in rechten und linken Klemmhaltern verwendbar.

Indexable inserts can be used in right and left hand toolholders.

P	●
M	○
K	○
N	-
S	-
H	-

HM-Sorten
Carbide grades

Einstechen (außen und innen)

Grooving (external and internal)



Wendeschneidplatte

Indexable insert

S64T

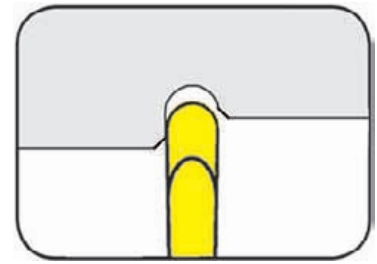

Vollradius	Full radius	0,5-1,5 mm
------------	-------------	------------

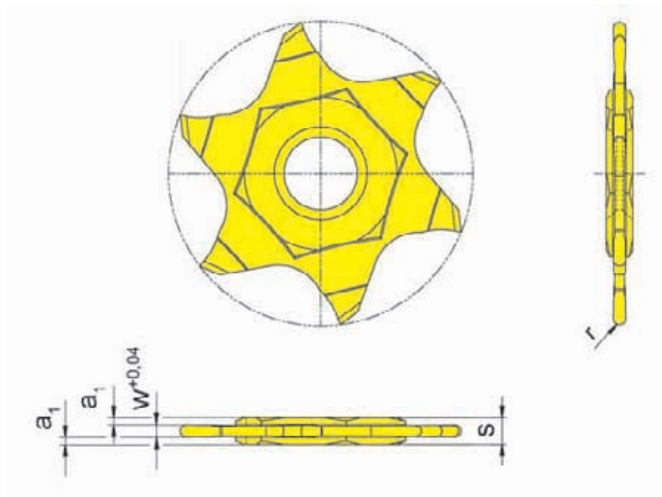

für Klemmhalter
for Toolholder

Typ H64T
Type



Bestellnummer Part number	w	a ₁	r	s	Größe Size	EG55
S64T.0100.05	1,0	0,59	0,50	2,2	01	▲
S64T.0120.06	1,2	0,49	0,60	2,2	01	▲
S64T.0160.08	1,6	0,29	0,80	2,2	01	▲
S64T.0200.10	2,0	0,09	1,00	2,2	01	▲
S64T.0250.12	2,5	0,09	1,25	2,7	02	▲
S64T.0300.15	3,0	0,09	1,50	3,2	02	▲

▲ ab Lager / on stock Δ 4 Wochen / 4 weeks x auf Anfrage / upon request

● empfohlen / recommended

o bedingt einsetzbar / alternative recommendation

- nicht geeignet / not suitable

■ unbeschichtete HM-Sorten / uncoated grades

■ beschichtete HM-Sorten / coated grades

■ bestückt/Cermet / brazed/Cermet

Abmessungen in mm

Dimensions in mm

Wendeschneidplatten sind in rechten und linken Klemmhaltern verwendbar.

Indexable inserts can be used in right and left hand toolholders.

P	●
M	○
K	○
N	-
S	-
H	-

HM-Sorten
Carbide grades

Einstechen und Abstechen

Grooving and Parting Off



Wendeschneidplatte

Indexable insert

S64T

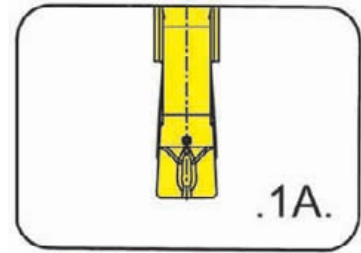

Stechbreite	Width of groove	1,5-3 mm
-------------	-----------------	----------

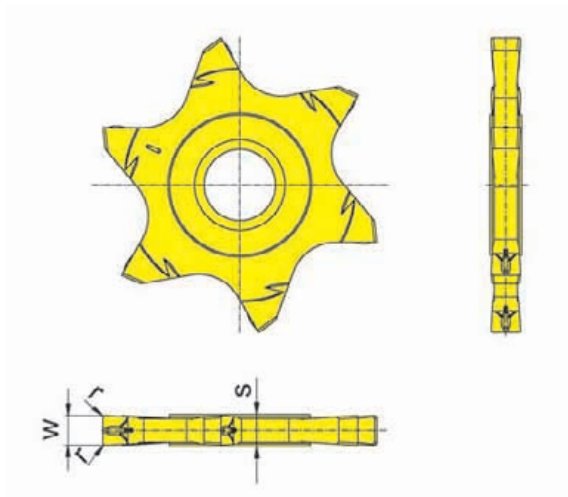

für Klemmhalter
for Toolholder

Typ H64T
Type

Bestellnummer Part number	w	r	s	Größe Size	EG55
S64T.0150.1A2	1,5	0,2	2,2	01	▲
S64T.0200.1A2	2,0	0,2	2,2	01	▲
S64T.0250.1A2	2,5	0,2	2,7	02	▲
S64T.0300.1A2	3,0	0,2	3,2	02	▲

▲ ab Lager / on stock Δ 4 Wochen / 4 weeks x auf Anfrage / upon request

● empfohlen / recommended

o bedingt einsetzbar / alternative recommendation

- nicht geeignet / not suitable

■ unbeschichtete HM-Sorten / uncoated grades

■ beschichtete HM-Sorten / coated grades

■ bestückt/Cermet / brazed/Cermet

Abmessungen in mm

Dimensions in mm

Wendeschneidplatten sind in rechten und linken Klemmhaltern verwendbar.

Indexable inserts can be used in right and left hand toolholders.

P	●
M	○
K	○
N	-
S	-
H	-

HM-Sorten
Carbide grades

Einstechen und Längsdrehen

Grooving and Side Turning



Wendeschneidplatte

Indexable insert

S64T

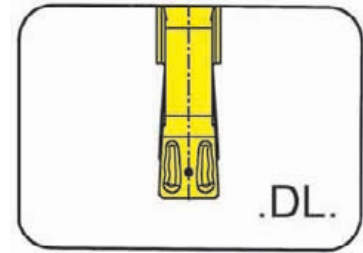

Stechbreite	Width of groove	1,5-3 mm
-------------	-----------------	----------

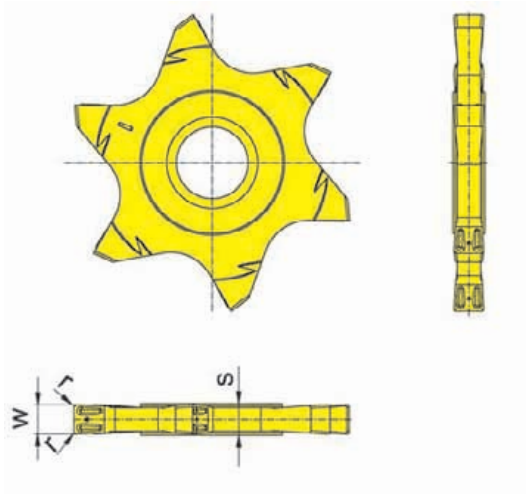

für Klemmhalter
for Toolholder

Typ H64T
Type

Bestellnummer Part number	w	r	s	Größe Size	EG55
S64T.0150.DL2	1,5	0,2	2,2	01	▲
S64T.0150.DL4	1,5	0,4	2,2	01	△
S64T.0200.DL2	2,0	0,2	2,2	01	▲
S64T.0200.DL4	2,0	0,4	2,2	01	△
S64T.0250.DL2	2,5	0,2	2,7	02	▲
S64T.0250.DL4	2,5	0,4	2,7	02	△
S64T.0300.DL2	3,0	0,2	3,2	02	▲
S64T.0300.DL4	3,0	0,4	3,2	02	△

▲ ab Lager / on stock △ 4 Wochen / 4 weeks x auf Anfrage / upon request

● empfohlen / recommended

o bedingt einsetzbar / alternative recommendation

- nicht geeignet / not suitable

■ unbeschichtete HM-Sorten / uncoated grades

■ beschichtete HM-Sorten / coated grades

■ bestückt/Cermet / brazed/Cermet

Abmessungen in mm

Dimensions in mm

Wendeschneidplatten sind in rechten und linken Klemmhaltern verwendbar.

Indexable inserts can be used in right and left hand toolholders.

P	●
M	○
K	○
N	-
S	-
H	-

HM-Sorten
Carbide grades

Q

Q





R

**Werkzeuge für
Langdrehmaschinen**

**Tools for
Swiss Type Machines**

für Schneidplatten
for Inserts

105

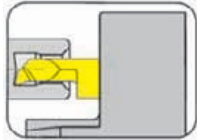

Seite/Page
R3, R5-R6



Seite/Page
R7



Seite/Page
R8

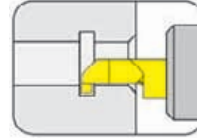

Seite/Page
R4, R9, R11

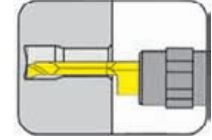

Seite/Page
R10

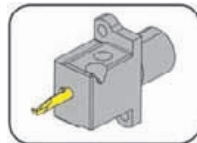

Seite/Page
R12

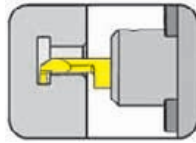

Seite/Page
R13-R20



Seite/Page
R23-R28

108

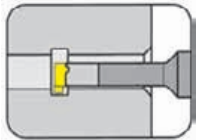

Seite/Page
R29

S100

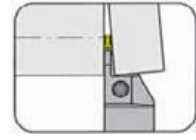

Seite/Page
R31

111

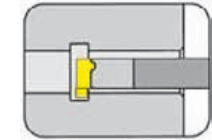

Seite/Page
R30

217

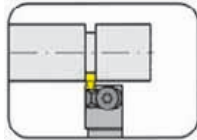

Seite/Page
R36

S224

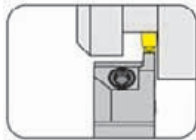

Seite/Page
R40-R41

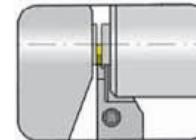

Seite/Page
R42-R44

264

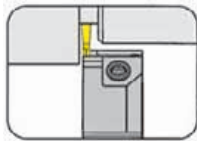

Seite/Page
R32-R34

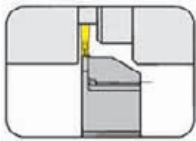

Seite/Page
R35

S274

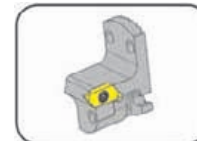

Seite/Page
R37-R38

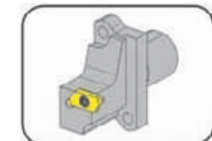

Seite/Page
R39

312

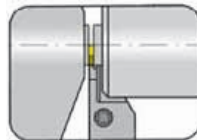

Seite/Page
R42-R44, R46

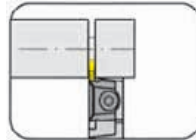

Seite/Page
R45



Seite/Page
R47

Zubehör
Additional equipment

Seite/Page
R48

Klemmhalter

Toolholder

B105

mit innerer Kühlmittelzufuhr
with through coolant supply

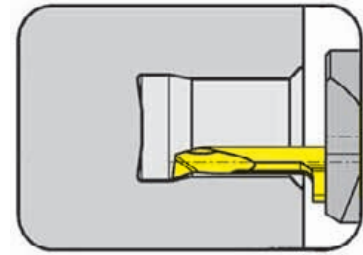

Bohrungs-Ø ab
Stechtiefe
Stechbreite bis

Bore Ø from
Depth of groove
Width of groove up to

0,2 mm
2,5 mm
2 mm

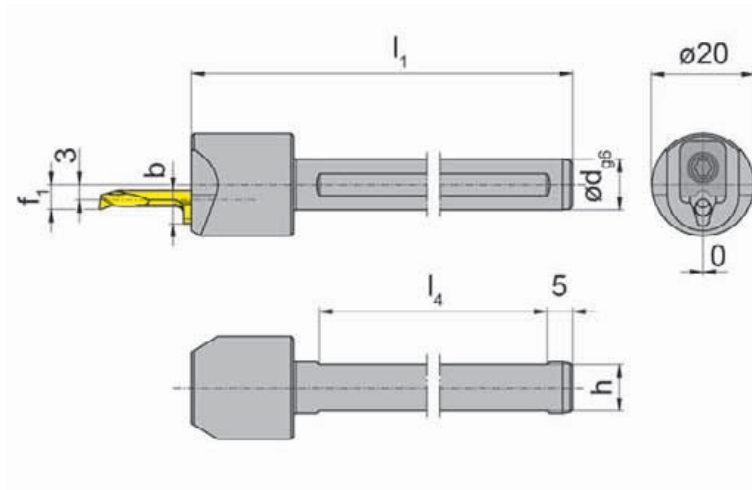

Schneidplatte
Insert

Typ 105
Type

R

Abbildung = rechtsschneidend
Picture = right hand cutting version

Stirnseitige Klemmung!
Face clamped insert!

Bestellnummer Part number	d	l ₁	h	l ₄	f ₁	*b
B105.0010.S.03	10	80	9	50	4,3	5,9
B105.0012.S.03	12	80	11	50	4,3	5,9
B105.0016.S.03	16	80	14	50	4,3	5,9
B105.0020.S.03	20	90	18	55	4,3	5,9
B105.0025.S.03	25	100	23	55	5,9	5,9
B105.0010.S.04	10	80	9	50	4,3	6,4
B105.0012.S.04	12	80	11	50	4,9	6,4
B105.0016.S.04	16	80	14	50	4,9	6,4
B105.0020.S.04	20	90	18	55	4,9	6,4
B105.0025.S.04	25	100	23	55	6,4	6,4
B105.0010.S.05	10	80	9	50	4,3	7,0
B105.0012.S.05	12	80	11	50	6,3	7,0
B105.0016.S.05	16	80	14	50	6,3	7,0
B105.0020.S.05	20	90	18	55	6,3	7,0
B105.0025.S.05	25	100	23	55	7,0	7,0

Weitere Abmessungen auf Anfrage
Further sizes upon request

*b = Schneidplattenhöhe
*b = Height of insert

Abmessungen in mm
Dimensions in mm

Bestellhinweis:

Klemmhalter sind jeweils für rechte und linke Schneidplatten verwendbar.

Ordering note:

Toolholders can be used with right and left hand inserts.

Das Anzugsdrehmoment der Schrauben finden Sie in den Technischen Hinweisen.

For torque specification of the screw, please see Technical Instructions.

Ersatzteile

Spare parts

Klemmhalter Toolholder	Spannelement Clamp	TORX PLUS®-Schlüssel TORX PLUS® Wrench
B105.00...S.03	010.0105.03	T15PL
B105.00...S.04	010.0105.04	T15PL
B105.00...S.05	010.0105.05	T15PL

Einstechen und Ausdrehen

Grooving and Boring



Klemmhalter

Toolholder

H105

mit Schraubklemmung
with screwed clamping

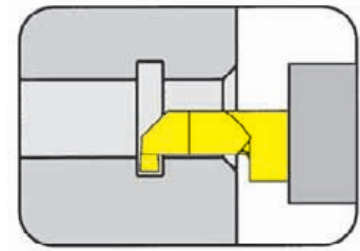

Bohrungs-Ø ab	Bore Ø from	0,2 mm
---------------	-------------	--------

Schneidplatte
Insert

Typ 105
Type

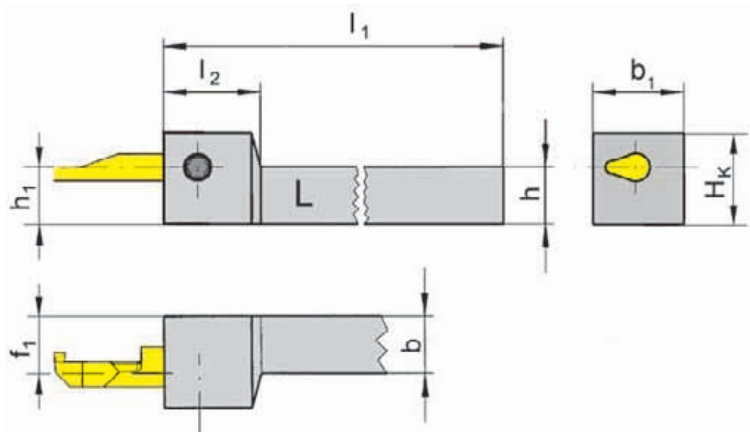

L = links wie gezeichnet
L = left hand version shown

R = rechts spiegelbildlich
R = right hand version

Bestellnummer Part number	h	b	f ₁	H _k	l ₂	b ₁	h ₁	l ₁
R/LH105.0808.01	8	8	7,5	14	17	16	8	90
R/LH105.1010.01	10	10	7,5	16	17	16	10	90
R/LH105.1212.01	12	12	7,5	18	17	16	12	90
R/LH105.1616.01	16	16	7,5	22	17	16	16	110

Ausführung R oder L angeben
State R or L version

Abmessungen in mm
Dimensions in mm

Weitere Abmessungen auf Anfrage
Further sizes upon request

Das Anzugsdrehmoment der Schrauben finden Sie in den Technischen Hinweisen.
For torque specification of the screw, please see Technical Instructions.

Ersatzteile

Spare Parts

Klemmhalter Toolholder	Spannschraube Screw	TORX PLUS®-Schlüssel TORX PLUS® Wrench
R/LH105...	6.075T15P	T15PQ

Einstecken und Ausdrehen

Grooving and Boring



Klemmhalter

Toolholder

HC105

mit Schraubklemmung
with screwed clamping

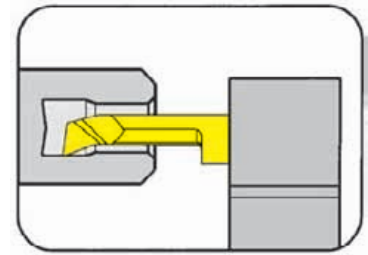

Bohrungs-Ø ab	Bore Ø from	0,2 mm
---------------	-------------	--------

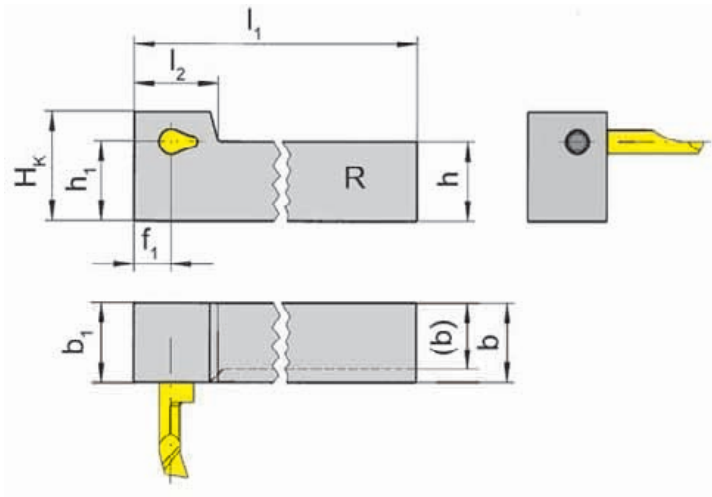

Schneidplatte
Insert

Typ 105
Type



R = rechts wie gezeichnet
R = right hand version shown

L = links spiegelbildlich
L = left hand version

Bestellnummer Part number	h	b	f ₁	H _k	b ₁	h ₁	l ₁	l ₂
R/LHC105.1212.01	12	12	7,5	18	16	12	90	17
R/LHC105.1616.01	16	16	7,5	22	16	16	130	17

Ausführung R oder L angeben
State R or L version

Abmessungen in mm
Dimensions in mm

Weitere Abmessungen auf Anfrage
Further sizes upon request

Das Anzugsdrehmoment der Schrauben finden Sie in den Technischen Hinweisen.
For torque specification of the screw, please see Technical Instructions.

Ersatzteile

Spare Parts

Klemmhalter Toolholder	Spannschraube Screw	TORX PLUS®-Schlüssel TORX PLUS® Wrench
R/LHC105...	6.075T15P	T15PQ

Einstechen und Ausdrehen

Grooving and Boring



Klemmhalter

Toolholder

HC105

mit Schraubklemmung
with screwed clamping

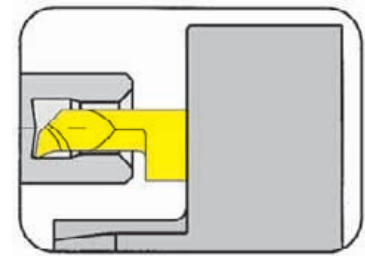

Bohrungs-Ø ab	Bore Ø from	0,2 mm
---------------	-------------	--------

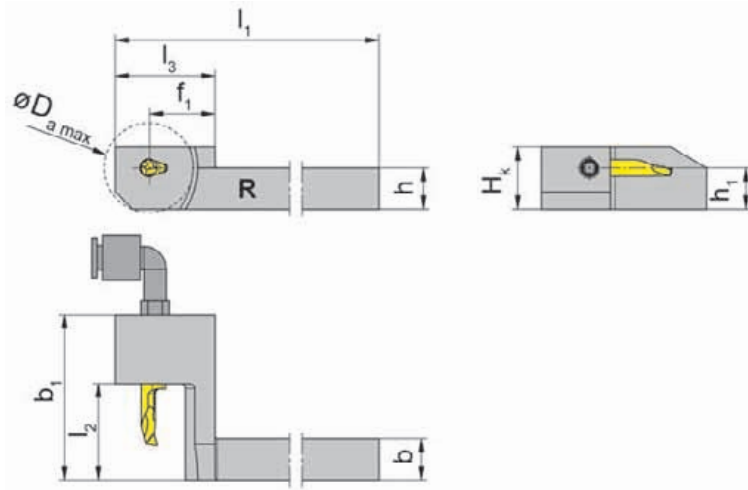

Schneidplatte
Insert

Typ 105
Type

Kühlmittelzufuhr über
Winkelverschraubung
Coolant supply through
cranked fitting

R = rechts wie gezeichnet
R = right hand version shown

L = links spiegelbildlich
L = left hand version

Bestellnummer Part number	h	b	f ₁	H _k	b ₁	h ₁	D _{amax}	l ₁	l ₃	l ₂
R/LHC105.0707.21*	7	7	19	13	32,0	7	26	99	29	18
R/LHC105.0808.21*	8	8	19	13	32,0	8	26	99	29	18
RHC105.1010.11*	10	10	19	16	22,7	10	26	99	29	8
R/LHC105.1010.21	10	10	19	16	38,0	10	26	99	29	18
R/LHC105.1010.41	10	10	19	16	48,0	10	26	99	29	28
R/LHC105.1212.21	12	12	19	18	38,0	12	26	99	29	18
R/LHC105.1212.41	12	12	19	18	48,0	12	26	99	29	28
R/LHC105.1616.21	16	16	24	22	38,0	16	36	104	34	18
R/LHC105.1616.41	16	16	24	22	48,0	16	36	104	34	28

Ausführung R oder L angeben
State R or L version

Abmessungen in mm
Dimensions in mm

Weitere Abmessungen auf Anfrage
Further sizes upon request

Hinweis:

* = ohne Kühlmittelzufuhr!

Note:

* = no through coolant supply!

Das Anzugsdrehmoment der Schrauben finden Sie in den Technischen Hinweisen.

For torque specification of the screw, please see Technical Instructions.

Ersatzteile

Spare Parts

Klemmhalter Toolholder	Spannschraube Screw	TORX PLUS®-Schlüssel TORX PLUS® Wrench	SMC Winkelverschraubung SMC angle screwing
R/LHC105.0707.21/0808.21	6.075T15P	T15PQ	
R/LHC105...11	6.075T15P	T15PQ	
R/LHC105....	6.075T15P	T15PQ	KQ2L06-M5

Einstecken und Ausdrehen

Grooving and Boring



Grundhalter

Basic toolholder

HC105

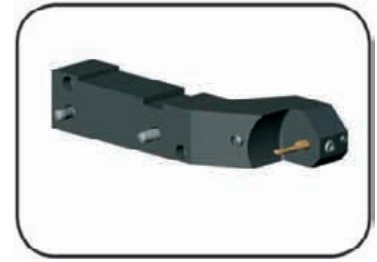

Bohrungs-Ø ab	Bore Ø from	0,2 mm
---------------	-------------	--------

Werkzeug für Tornos
Tool for Tornos

Schneidplatte
Insert

Typ 105
Type

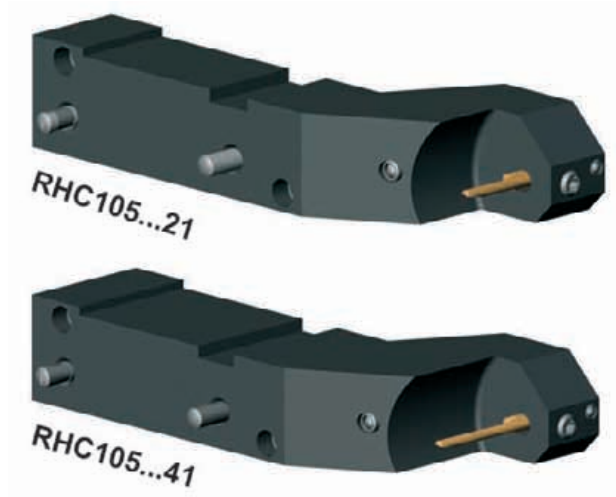

Bestellnummer Part number	Maschinentyp Machine type	Schneidplatte Insert
RHC105.0710.21	EvoDECO 10	105...21 l ₂ bis 15 mm
RHC105.0710.41	EvoDECO 10	105...41 l ₂ bis 25 mm

Weitere Abmessungen auf Anfrage
Further sizes upon request

Abmessungen in mm
Dimensions in mm

Das Anzugsdrehmoment der Schrauben finden Sie in den Technischen Hinweisen.
For torque specification of the screw, please see Technical Instructions.

Ersatzteile

Spare Parts

Grundhalter Basic toolholder	Spannschraube Screw	SMC Winkelverschraubung SMC angle screwing	TORX PLUS®-Schlüssel TORX PLUS® Wrench	Zylinderstift Straight pin
RHC105...	6.075T15P	KQ2L06-M5	T15PQ	020.0518.1610



Einstecken und Abstecken

Grooving and Parting Off



Grundhalter

Basic toolholder

760

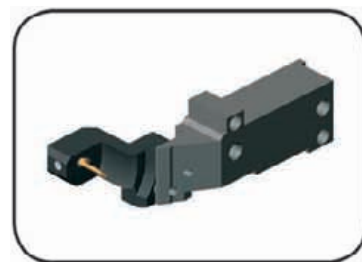

Stechtiefe bis	Depth of groove up to	0,2 mm
----------------	-----------------------	--------

Werkzeug für Tornos
Tool for Tornos

Kassette
Cassette

Typ RKC760
Type



R

Bestellnummer Part number	Maschinentyp Machine type	Kassette Cassette	Schneidplatte Insert
L760.0013.K1	EvoDECO 16	RKC760.0105.21	105...21 I ₂ bis 15 mm
L760.2026.K1	EvoDECO 20/EvoDECO 32	RKC760.0105.41	105...41 I ₂ bis 25 mm

Weitere Abmessungen auf Anfrage
Further sizes upon request

Abmessungen in mm
Dimensions in mm

Ersatzteile

Spare Parts

Grundhalter Basic toolholder	Inbus-Schlüssel Wrench
L760...	SW5,0 DIN911

Einstechen und Ausdrehen

Grooving and Boring



Klemmhalter

Toolholder

VDI

mit innerer Kühlmittelzufuhr
with through coolant supply

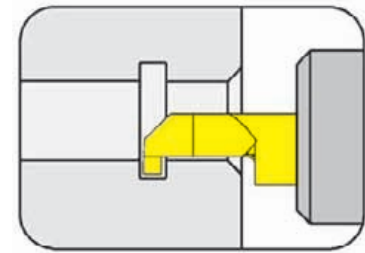

Bohrungs-Ø ab Bore Ø from 0,2 mm

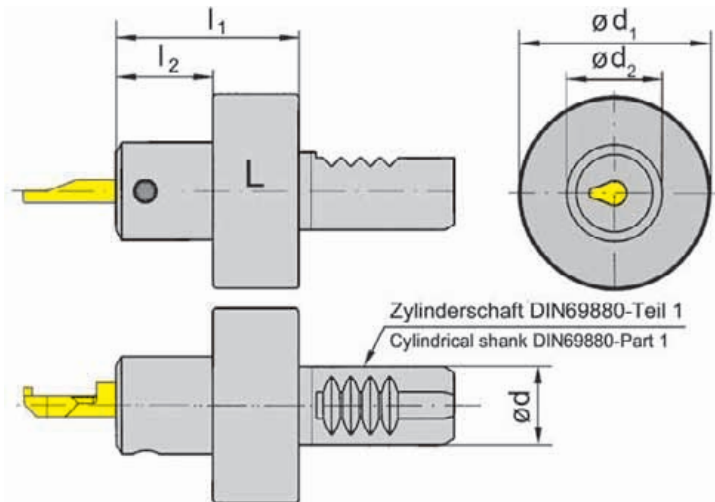

L = links wie gezeichnet
L = left hand version shown

R = rechts spiegelbildlich
R = right hand version

Schneidplatte
Insert

Typ 105
Type

R

Bestellnummer Part number	d	l ₁	l ₂	d ₂	d ₁
VDI16.L105.20.01	16	38	20	20	40
VDI16.R105.20.01	16	38	20	20	40
VDI20.L105.20.01	20	38	20	20	50
VDI20.R105.20.01	20	38	20	20	50
VDI25.L105.20.01	25	38	20	20	58
VDI25.R105.20.01	25	38	20	20	58
VDI30.L105.20.01	30	38	20	20	68
VDI30.R105.20.01	30	38	20	20	68
VDI40.L105.20.01	40	38	20	20	83
VDI40.R105.20.01	40	38	20	20	83

Ausführung R oder L angeben
State R or L version

Abmessungen in mm
Dimensions in mm

Weitere Abmessungen auf Anfrage
Further sizes upon request

Das Anzugsdrehmoment der Schrauben finden Sie in den Technischen Hinweisen.
For torque specification of the screw, please see Technical Instructions.

Ersatzteile

Spare Parts

Klemmhalter Toolholder	Spannschraube Screw	TORX PLUS®-Schlüssel TORX PLUS® Wrench
VDI16...	6.075T15P	T15PQ

Einstechen und Ausdrehen

Grooving and Boring



Klemmhalter

Toolholder

B105

mit innerer Kühlmittelzufuhr
with through coolant supply

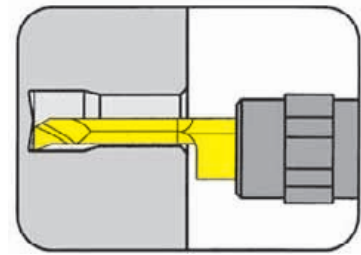

Bohrungs-Ø ab	Bore Ø from	<3/>5 mm
---------------	-------------	----------

Schneidplatte
Insert

Typ 105 $\varnothing \leq 3$
Type 105 $\varnothing \geq 5$



Abbildung = rechtsschneidend
Picture = right hand cutting version

Bestellnummer Part number	d	l ₁	h	l ₄	d ₂	f	SW	*b
B105.0010.9.01	10	100	9	50	11	1,6	10	5,9
B105.0012.11.01	12	100	11	50	16	1,2	13	7,0
B105.0016.11.01	16	100	15	50	16	1,2	13	7,0

Weitere Abmessungen auf Anfrage
Further sizes upon request

Abmessungen in mm
Dimensions in mm

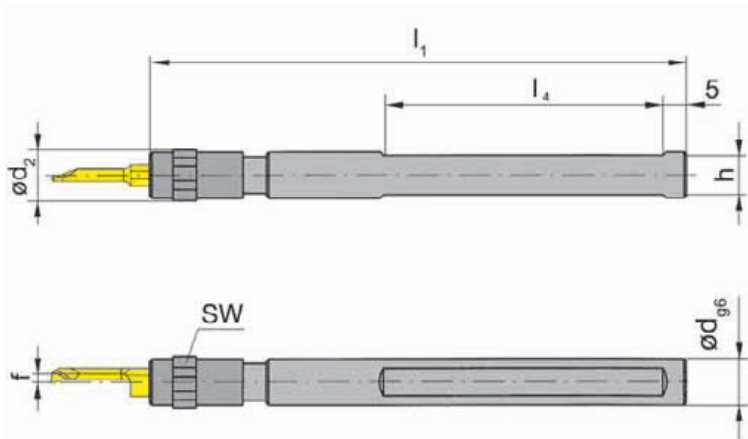
* b = Schneidplattenhöhe
* b = Height of insert

Klemmhalter sind jeweils für rechte und linke Schneidplatten verwendbar.
Toolholders can be used with right and left hand inserts.

Ersatzteile

Spare Parts

Klemmhalter Toolholder	Spannmutter Clamping nut
B105.0010.9.01	020.0010.1719
B105.00...	020.0016.1999

Einstechen und Ausdrehen

Grooving and Boring



Klemmhalter

Toolholder

B105

mit innerer Kühlmittelzufuhr
with through coolant supply

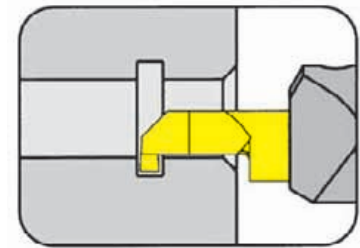

Bohrungs-Ø ab Stechtiefe Stechbreite	Bore Ø from Depth of groove Width of groove	0,2 mm 2,5 mm 2 mm
--	---	--------------------------

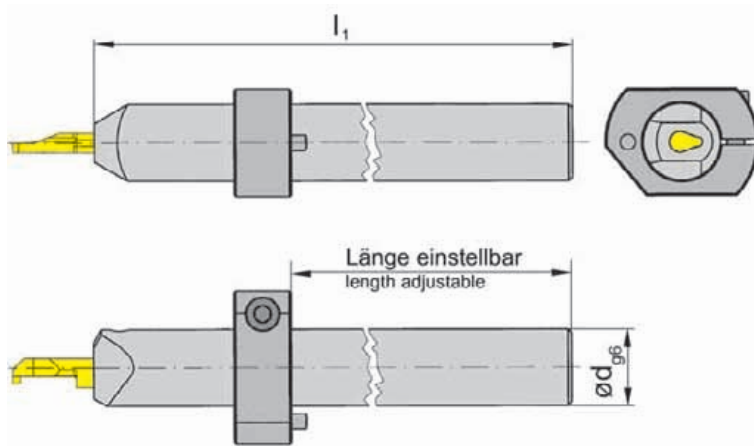

Schneidplatte
Insert

Typ 105
Type

Abbildung = rechtsschneidend
Picture = right hand cutting version

Bestellnummer Part number	d	l ₁
B105.0020.2.01	20	150
B105.0025.2.01	25	150

Weitere Abmessungen auf Anfrage
Further sizes upon request

Abmessungen in mm
Dimensions in mm

Bestellhinweis:

Klemmhalter sind jeweils für rechte und linke Schneidplatten verwendbar.

Ordering note:

Toolholders can be used with right and left hand inserts.

Stelling ist nicht im Lieferumfang enthalten - bitte separat bestellen!

Adjusting ring is not combined with the toolholder - separate order required!

Das Anzugsdrehmoment der Schrauben finden Sie in den Technischen Hinweisen.

For torque specification of the screw, please see Technical Instructions.

Stelling Adjusting ring	d	Maschinentyp Type of machine
020.0020.1665	20	Tornos
020.0025.2234	25	Tornos

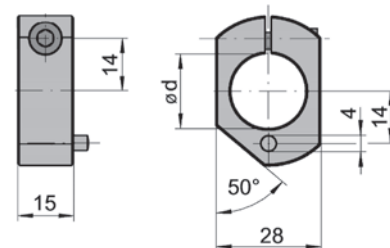

Ersatzteile

Spare Parts

Klemmhalter Toolholder	Spannschraube Screw	SMC Winkelverschraubung SMC angle screwing	TORX PLUS®-Schlüssel TORX PLUS® Wrench
B105...	6.075T15P	KQ2L06-M5	T15PQ

Einstechen und Ausdrehen

Grooving and Boring



Klemmhalter

Toolholder

B105

mit innerer Kühlmittelzufuhr
with through coolant supply

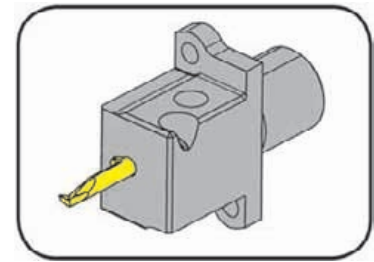

Bohrungs-Ø ab Stechtiefe Stechbreite	Bore Ø from Depth of groove Width of groove	0,2 mm 2,5 mm 2 mm
--	---	--------------------------

Kühlmittelzufuhr G1/8" Lochbild 13,7 x 37,6 mm
Through coolant supply G1/8" Hole pattern 13,7 x 37,6 mm

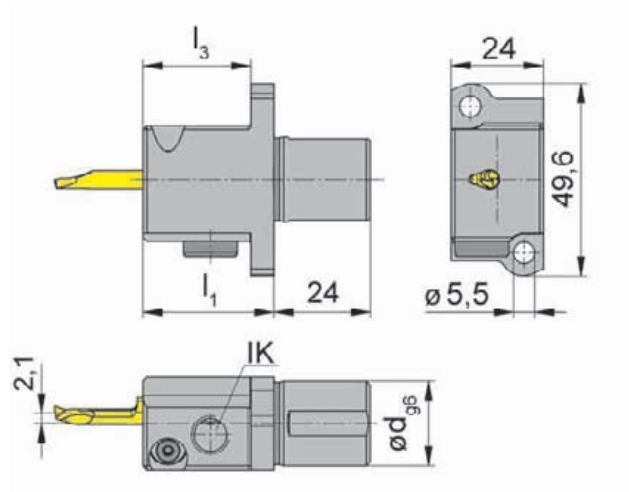

Schneidplatte
Insert

Typ 105
Type

R

für Star
Langdrehautomaten
for Swiss type machines Star

Abbildung = linksschneidend
Picture = left hand cutting version

Bestellnummer Part number	d	l ₁	l ₃
LB105.A022.26.31	22	35	29

Weitere Abmessungen auf Anfrage
Further sizes upon request

Abmessungen in mm
Dimensions in mm

Das Anzugsdrehmoment der Schrauben finden Sie in den Technischen Hinweisen.
For torque specification of the screw, please see Technical Instructions.

Star Langdrehautomaten: ECAS-12/20, SB16D/E, SR-20, SR20J/JN, RS-20RII, RS-20RIII, RS-20RIV, RS-32J/JN, SW-12RIII

Swiss Type Machines Star: ECAS-12/20, SB16D/E, SR-20, SR20J/JN, RS-20RII, RS-20RIII, RS-20RIV, RS-32J/JN, SW-12RII

Ersatzteile

Spare Parts

Klemmhalter Toolholder	Inbus-Schlüssel Wrench	Spannkeil Clamping	TORX PLUS®-Schlüssel TORX PLUS® Wrench
LB105.A022.26.31	SW3,0 DIN911	070.0010.0118	T10PL

Einstechen und Ausdrehen

Grooving and Boring



Grundhalter

Basic toolholder

BGT

ohne Einbauhalter
without cartridge

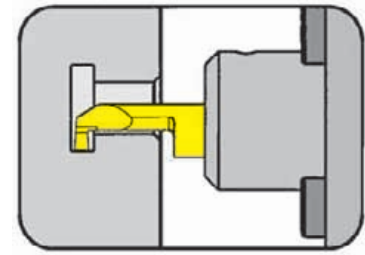

Verstellbare Rundschäfte für Halter BKT105.2445.01/02
Adjustable round shanks for toolholder BKT105.2445.01/02

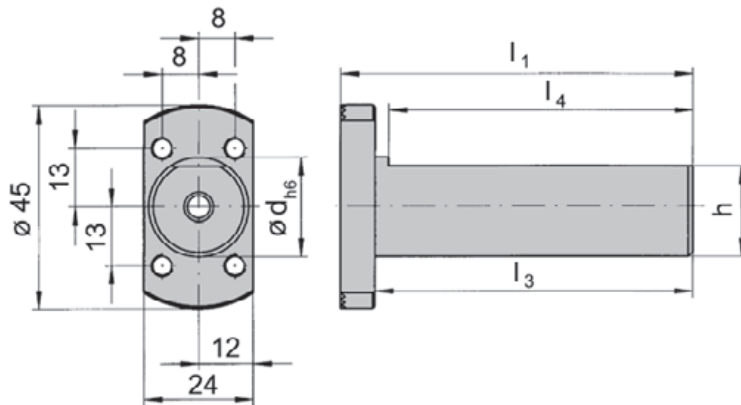

mit innerer
Kühlmittelzufuhr
with through coolant supply

Bestellnummer Part number	d	l ₁	h	l ₃	l ₄	Maschinentyp Machine type
BGT001.0010.50	10	57,50	9	50	47	-
BGT001.0016.21	16	28,50	14	21	18	Star
BGT001.0R16.21	16	28,50	14	21	18	Star
BGT001.0020.100	20	107,50	18	100	97	Tornos
BGT001.0022.30	22	36,35	20	30	27	Star
BGT001.0022.70	22	77,50	20	70	67	Star
BGT001.0025.70	25	77,50	23	70	67	-
BGT001.0028.80	28	87,50	26	81	77	Traub

Weitere Abmessungen auf Anfrage
Further sizes upon request

Abmessungen in mm
Dimensions in mm

Hinweis:

BGT001.0022.30 ohne innere Kühlmittelzufuhr

Note:

BGT001.0022.30 without through coolant supply

Ersatzteile

Spare parts

Grundhalter Basic toolholder	Spannschraube Screw	Inbus-Schlüssel Wrench	O-Ring O-ring
BGT001...	M 5 x 10 DIN 912-12.9	SW4,0 DIN911	DIN3770-7x3
BGT001.0022.30	M 5 x 10 DIN 912-12.9	SW4,0 DIN911	

R

Einstecken und Ausdrehen

Grooving and Boring



Einstellbare Halter

Adjustable holder

BKT

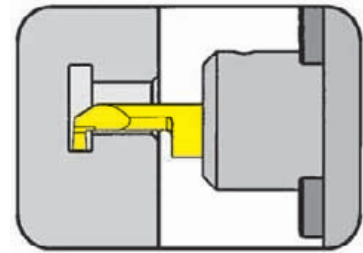

Bohrungs-Ø ab
Stechtiefe bis
Stechbreite bis

Bore Ø from
Depth of groove up to
Width of groove up to

0,2 mm
2,5 mm
2 mm

Schneidplatte
Insert

Typ 105
Type

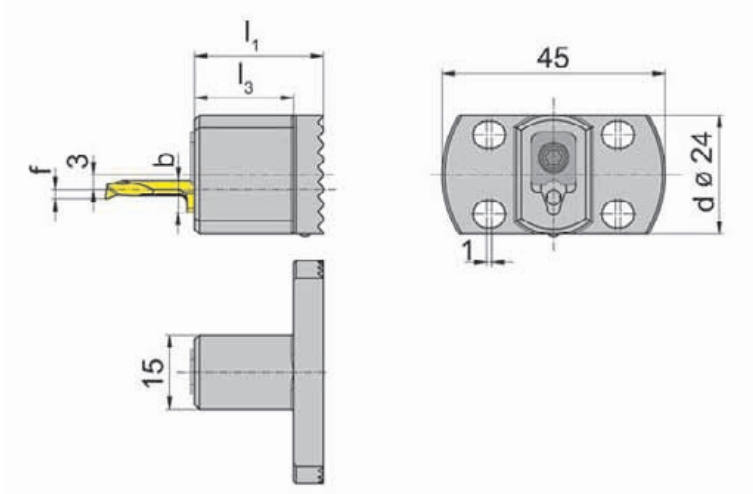

Bestellnummer Part number	l_3	d	l_1	*b
BKT105.2445.S.03	20	24	26	5,9
BKT105.2445.S.04	20	24	26	6,4
BKT105.2445.S.05	20	24	26	7,0

Weitere Abmessungen auf Anfrage
Further sizes upon request

f siehe Schneidplatte Typ 105
f see inserts type 105

Abmessungen in mm
Dimensions in mm

* b = Schneidplattenhöhe
* b = Height of insert

Ersatzteile

Spare parts

Klemmhalter Toolholder	Spannelement Clamp	TORX PLUS®-Schlüssel TORX PLUS® Wrench
BKT105.2445.S.03	010.0105.03	T15PL
BKT105.2445.S.04	010.0105.04	T15PL
BKT105.2445.S.05	010.0105.05	T15PL

Einstecken und Ausdrehen

Grooving and Boring



Einstellbare Halter

Adjustable holder

BKT

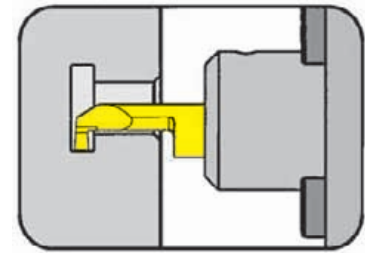

Bohrungs-Ø ab
Stechtiefe bis
Stechbreite bis

Bore Ø from
Depth of groove up to
Width of groove up to

0,2 mm
2,5 mm
2 mm

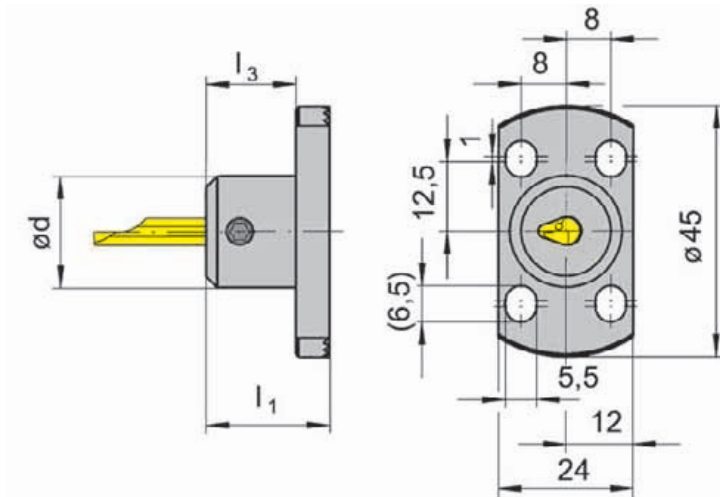

Schneidplatte
Insert

Typ 105
Type

mit innerer
Kühlmittelzufuhr
with through coolant supply

Bestellnummer Part number	l_3	d	l_1
BKT105.2445.01	16	20	22
BKT105.2445.02	26	20	32

Weitere Abmessungen auf Anfrage
Further sizes upon request

Abmessungen in mm
Dimensions in mm

Hinweis:

Bei Verwendung von Einbauhalter HORN Typ BKT mit Grundhalter Graf Typ G oder Zwischenstück Graf Typ N und Z keine Innenkühlung möglich.

Note:

If using cartridge HORN type BKT with basic toolholder Graf G or adaptor Graf type N and Z, no through coolant supply will be possible.

Das Anzugsdrehmoment der Schrauben finden Sie in den Technischen Hinweisen.

For torque specification of the screw, please see Technical Instructions.

Ersatzteile

Spare Parts

Einstellbare Halter Adjustable holder	Spannschraube Screw	TORX PLUS®-Schlüssel TORX PLUS® Wrench
BKT105...	6.075T15P	T15PQ

Einstecken und Ausdrehen

Grooving and Boring



Grundhalter

Basic toolholder

BGT

ohne Einbauhalter
without cartridge

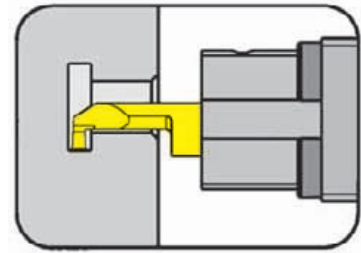

Verstellbare Rundschäfte für Halter BKT105.2327.01
Adjustable round shanks for toolholder BKT105.2327.01

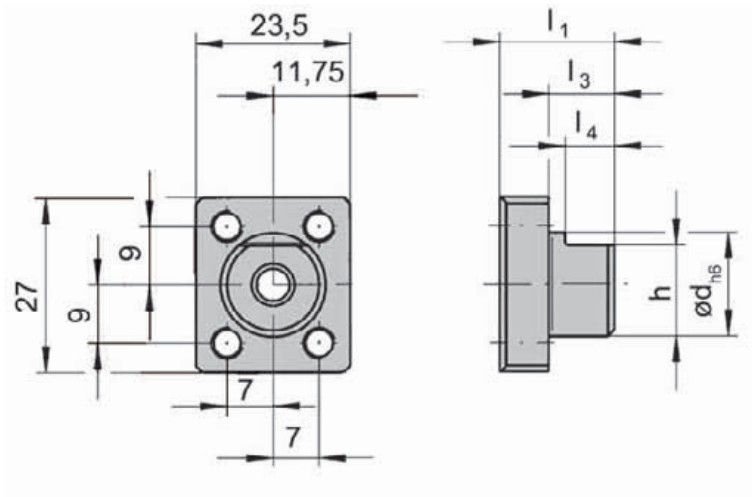

mit innerer
Kühlmittelzufuhr
with through coolant supply

Bestellnummer Part number	d	l ₁	h	l ₃	l ₄	Maschinentyp Machine type
BGT001.1627.10	16	17,5	14	10	7,5	Star

Weitere Abmessungen auf Anfrage
Further sizes upon request

Abmessungen in mm
Dimensions in mm

Ersatzteile

Spare Parts

Grundhalter Basic toolholder	Spannschraube Screw	Inbus-Schlüssel Wrench	O-Ring O-ring
BGT001.1627.10	M 5 x 10 DIN 912-12.9	SW4,0 DIN911	DIN3770-7x3

Einstecken und Ausdrehen

Grooving and Boring



Einstellbare Halter

Adjustable holder

BKT

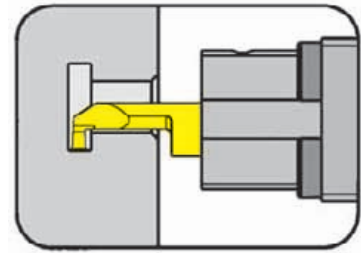

Bohrungs-Ø ab
Stechtiefe bis
Stechbreite bis

Bore Ø from
Depth of groove up to
Width of groove up to

0,2 mm
2,5 mm
2 mm

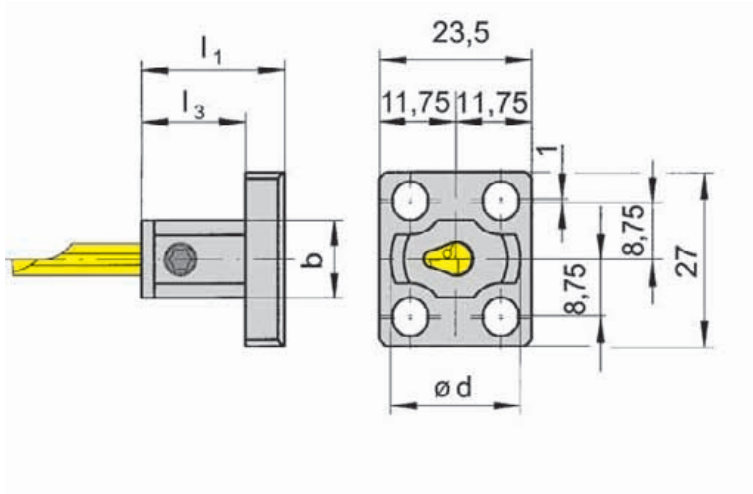

Schneidplatte
Insert

Typ 105
Type

R

mit innerer
Kühlmittelzufuhr
with through coolant supply

Bestellnummer Part number	d	l_1	l_3	b
BKT105.2327.01	20	22	16	12

Weitere Abmessungen auf Anfrage
Further sizes upon request

Abmessungen in mm
Dimensions in mm

Das Anzugsdrehmoment der Schrauben finden Sie in den Technischen Hinweisen.
For torque specification of the screw, please see Technical Instructions.

Ersatzteile

Spare Parts

Einstellbare Halter Adjustable holder	Spannschraube Screw	TORX PLUS®-Schlüssel TORX PLUS® Wrench
BKT105.2327.01	6.075T15P	T15PQ

Einstecken und Ausdrehen

Grooving and Boring



Grundhalter

Basic toolholder

BGT

ohne Einbauhalter
without cartridge

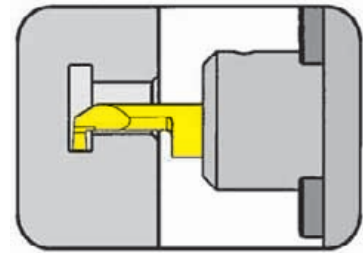

Verstellbare Rundschäfte für Halter BKT105.2327.01
Adjustable round shanks for toolholder BKT105.2327.01

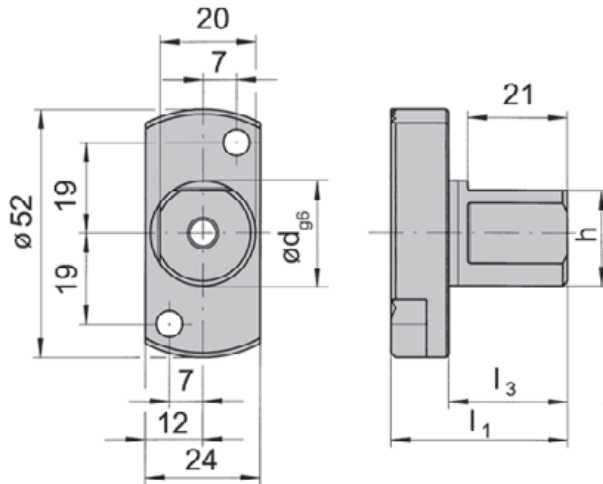

mit innerer
Kühlmittelzufuhr
with through coolant supply

Bestellnummer Part number	d	l ₁	h	l ₃	l ₄
BGT001.0R22.25	22	37	20	25	21

Weitere Abmessungen auf Anfrage
Further sizes upon request

Abmessungen in mm
Dimensions in mm

Ersatzteile

Spare Parts

Grundhalter Basic toolholder	Spannschraube Screw	Inbus-Schlüssel Wrench
BGT001.0R22.25	M 5 x 10 DIN 912-12.9	SW4,0 DIN911

Grundhalter Graf

Basic toolholder Graf

G

ohne Einbauhalter
without cartridge



für einstellbare Halter Graf Typ N und HORN BKT105.2445.01/02
for adjustable holder Graf type N and HORN BKT105.2445.01/02

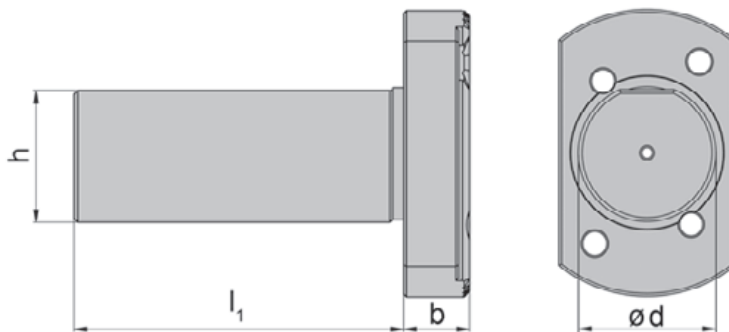

R

Bestellnummer Part number	d	l ₁	h	b	Maschinentyp Machine type
G016021	16	21	14	6	Star
G016040	16	40	14	6	Traub/Manurhin
G034040	3/4"	40	18	6	Citizen
G034050	3/4"	50	18	6	Citizen
G034120	3/4"	120	18	6	Citizen
G020030	20	30	18	6	Citizen
G020040	20	40	18	6	Hanwha
G020100	20	100	18	6	Tornos
G020150	20	150	18	6	Manurhin/Tornos
G022023	22	23	20	6	Star
G022025SR1620R	22	25	20	12	Star
G022030	22	30	20	6	Star
G022030SR32	22	30	20	12	Star
G022070	22	70	20	6	Star

Weitere Abmessungen auf Anfrage
Further sizes upon request

Abmessungen in mm und Zoll
Dimensions in mm and inch

Grundhalter Graf

Basic toolholder Graf

G

ohne Einbauhalter
without cartridge

für einstellbare Halter Graf Typ N und HORN BKT105.2445.01/02
for adjustable holder Graf type N and HORN BKT105.2445.01/02

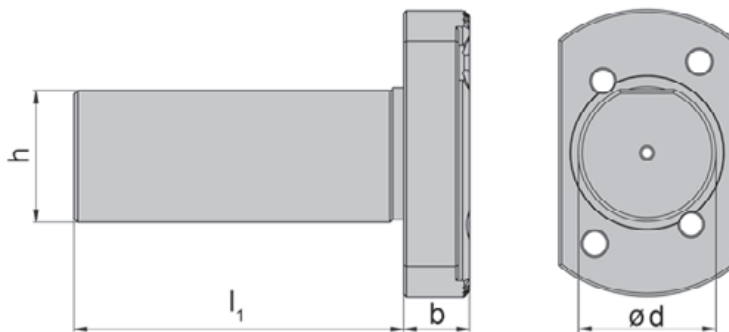

R

Bestellnummer Part number	d	l ₁	h	b	Maschinentyp Machine type
G025060	25	60	23	12	Hanwha
G025070	25	70	23	6	Manurhin/Tornos
G025100	25	100	23	6	Manurhin/Tornos
G025160	25	160	23	6	Manurhin/Tornos
G010060	1"	60	23	6	Citizen
G010100	1"	100	23	6	Citizen
G028006	28	6	26	12	Hanwha
G028080	28	80	26	12	Traub
G030045	30	45	27	12	Maier
G033040	33	40	31	12	Hanwha
G034020	34	20	32	12	Maier
G034044	34	44	32	12	Maier/Hanwha

Weitere Abmessungen auf Anfrage
Further sizes upon request

Abmessungen in mm und Zoll
Dimensions in mm and inch

Zwischenstück Graf

Adaptor Graf

Z

ohne Einbauhalter
without cartridge

für einstellbare Halter Graf Typ N und HORN BKT105.2445.01/02
for adjustable holder Graf type N and HORN BKT105.2445.01/02

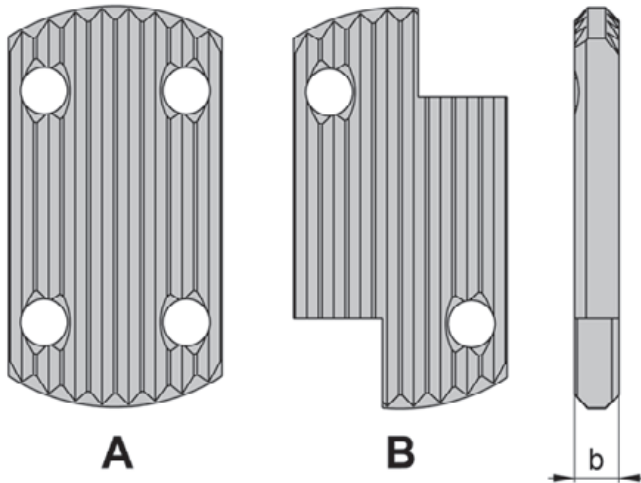

R

Bestellnummer Part number	b	Form Form
Z5	5	A
Z 10	10	A
Z15	15	A
Z 20	20	A
Z25	25	A
Z30	30	A
Z5SR16/20R	5	B
Z10SR16/20R	10	B
Z15SR16/20R	15	B
Z20SR16/20R	20	B
Z25SR16/20R	25	B
Z30SR16/20R	30	B

Weitere Abmessungen auf Anfrage
Further sizes upon request

Abmessungen in mm
Dimensions in mm

Zwischenstück Graf

Adaptor GRAF

N

ohne Einbauhalter
without cartridge



für einstellbare Halter Graf Typ N und HORN BKT105.2445.01/02
for adjustable holder Graf type N and HORN BKT105.2445.01/02

für Rückseitenbearbeitung
for back working

Bestellnummer N11

Part number

Für wahlweise 2 Einsätze
For alternatively 2 cartridges

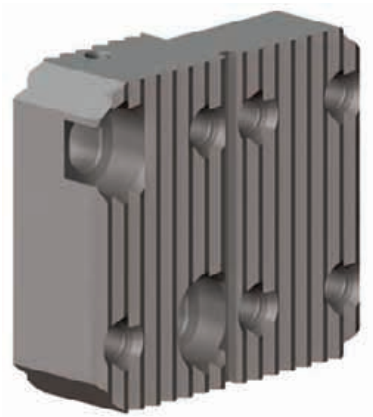

Bestellnummer N12

Part number

Für wahlweise 3 Einsätze
For alternatively 3 cartridges

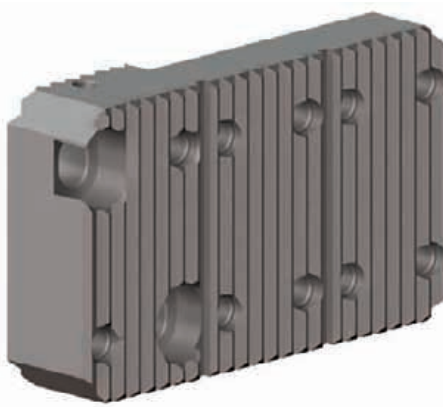

Bestellnummer N93IK

Part number

mit innerer Kühlmittelzufuhr
with through coolant supply



R

Einstechen und Ausdrehen

Grooving and Boring



Einstellbare Halter

Adjustable holder

N

Bohrungs-Ø ab	Bore Ø from	0,2 mm
Stechtiefe bis	Depth of groove up to	2,5 mm
Stechbreite bis	Width of groove up to	2 mm

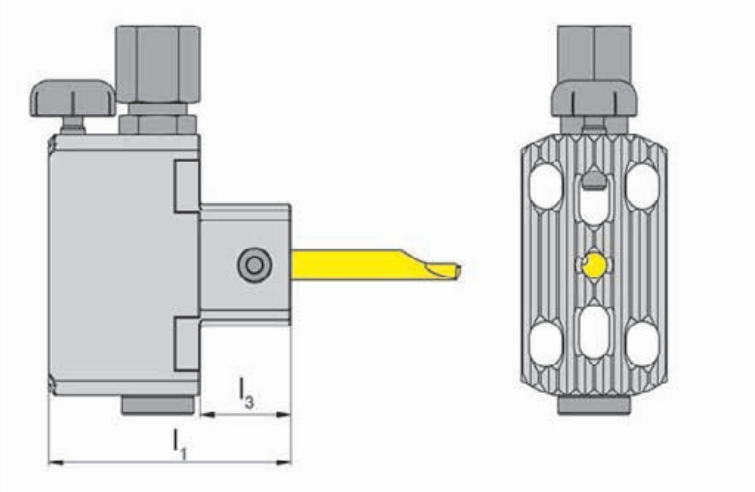

Schneidplatte
Insert

Typ 105
Type

mit innerer
Kühlmittelzufuhr
with through coolant supply

Bestellnummer Part number	l_1	l_3
N09IK	40	15

Weitere Abmessungen auf Anfrage
Further sizes upon request

Abmessungen in mm
Dimensions in mm

Ersatzteile

Spare Parts

Einstellbare Halter Adjustable holder	Spannschraube Screw	Höhenverstellungsschraube Screw to adjust the height	Kühlmittelanschluss Coolant supply
N09IK	6.075T15P	002.00.69	004.00.19

Einstellbare Halter

Adjustable holder

N

Bohrungs-Ø ab	Bore Ø from	0,2 mm
Stechtiefe bis	Depth of groove up to	2,5 mm
Stechbreite bis	Width of groove up to	2 mm

Schneidplatte
Insert

Typ 105
Type

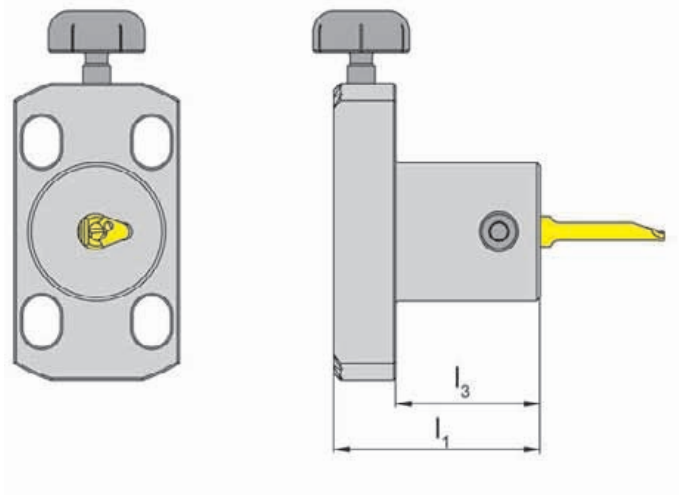

mit innerer
Kühlmittelzufuhr
with through coolant supply

Bestellnummer Part number	l_1	l_3
N09	30	20

Weitere Abmessungen auf Anfrage
Further sizes upon request

Abmessungen in mm
Dimensions in mm

Ersatzteile

Spare Parts

Einstellbare Halter Adjustable holder	Spannschraube Screw	Höhenverstellungsschraube Screw to adjust the height
N09	6.075T15P	002.00.69

Einstellbare Halter

Adjustable holder

N

mit Spannmutter ER16 / ER20 System Graf
with chucking nut ER16 / E20 system Graf

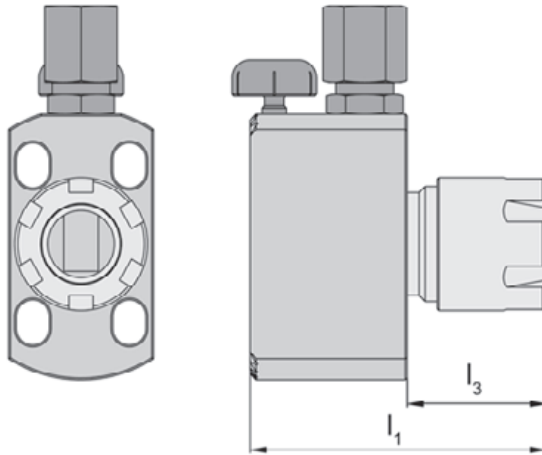

Grundhalter
Insert

Typ Horn BGT
Type Graf G

mit innerer
Kühlmittelzufuhr
with through coolant supply

Bestellnummer Part number	l_1	l_3	Spannmutter Clamping nut
N07IK	54	18	ER16
N41IK	64	26	ER20

Weitere Abmessungen auf Anfrage
Further sizes upon request

Abmessungen in mm
Dimensions in mm

Ersatzteile

Spare Parts

Einstellbare Halter Adjustable holder	Dichtscheibensatz D3 Sealing disc set D3	Höhenverstellungsschraube Screw to adjust the height	Kühlmittelanschluss Coolant supply	Spannmutter Clamping nut
N07IK	64.600.16.3-10	002.00.69	004.00.19	62.000.16
N41IK	64.600.20.3-13	002.00.69	004.00.19	62.000.20

Einstellbare Halter

Adjustable holder

N

mit Spannmutter ER16 System Graf
with chucking nut ER16 system Graf

Grundhalter
Insert

Typ Horn BGT
Type Graf G

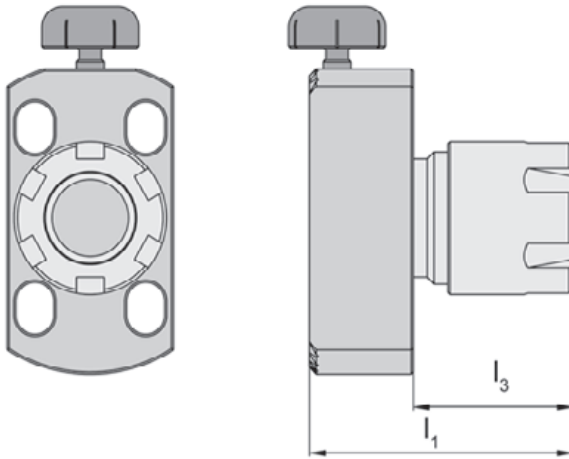

R

Bestellnummer Part number	l_1	l_3	Spannmutter Clamping nut
N07	37	18	ER16

Weitere Abmessungen auf Anfrage
Further sizes upon request

Abmessungen in mm
Dimensions in mm

Ersatzteile

Spare Parts

Einstellbare Halter Adjustable holder	Höhenverstellungsschraube Screw to adjust the height	Spannmutter Clamping nut
N07	002.00.69	62.000.16

Einstellbare Halter

Adjustable holder

N

mit Spannmutter ER11 / ER16 System Graf
with chucking nut ER11 / E16 system Graf

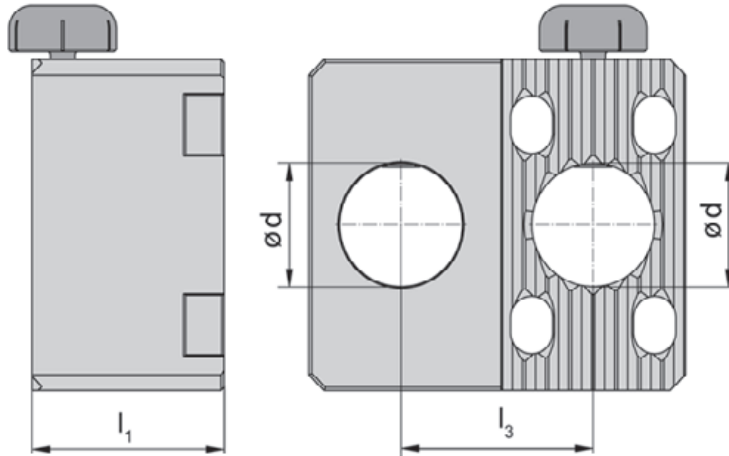

Grundhalter
Insert

Typ Horn BGT
Type Graf G

R

Bestellnummer Part number	d	l ₁	l ₃
N10	16	25	25

Weitere Abmessungen auf Anfrage
Further sizes upon request

Abmessungen in mm
Dimensions in mm

Ersatzteile

Spare Parts

Einstellbare Halter Adjustable holder	Gewindestift Threaded Pin	Höhenverstellungsschraube Screw to adjust the height
N10	002.00.11	002.00.69

Einstellbare Halter

Adjustable holder

N

für Vierkantschaft System Graf
for square shank system Graf



Grundhalter
Insert

Typ Horn BGT
Type Graf G

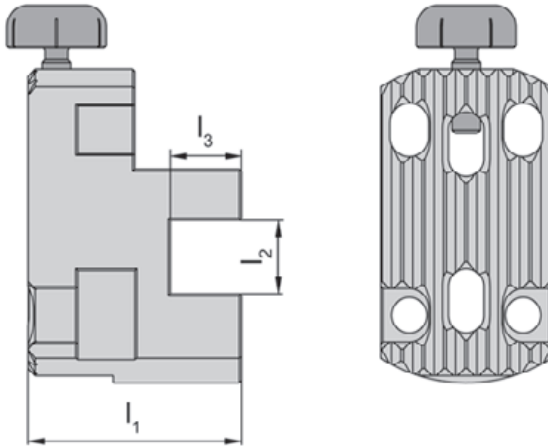

R

Bestellnummer Part number	l_1	l_3	l_2
N06	30	10	10

Weitere Abmessungen auf Anfrage
Further sizes upon request

Abmessungen in mm
Dimensions in mm

Ersatzteile

Spare Parts

Einstellbare Halter Adjustable holder	Gewindestift Threaded Pin	Höhenverstellungsschraube Screw to adjust the height
N06	002.00.11	002.00.69

Einstechen und Ausdrehen

Grooving and Boring



Klemmhalter

Toolholder

B108

mit innerer Kühlmittelzufuhr
with through coolant supply

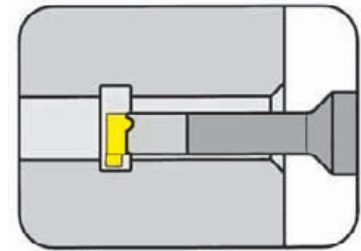

Bohrungs-Ø ab
Stechbreite bis

Bore Ø from
Width of groove up to

8 mm
2 mm

Schaftmaterial: Hartmetall (schwingungsarm)
Material of shank: Carbide - Giving a good vibration resistance

Schneidplatte
Insert

Typ 108
Type S108



Abbildung = rechtsschneidend
Picture = right hand cutting version

Bestellnummer Part number	d	l ₁	l ₂	h	l ₄	d ₁
B108.0008.00	8	60	12,5	7	35	6
B108.0008.01	8	70	21,0	7	40	6

Weitere Abmessungen auf Anfrage
Further sizes upon request

w, a, tmax und f siehe Schneidplatten
w, a, tmax and f see inserts

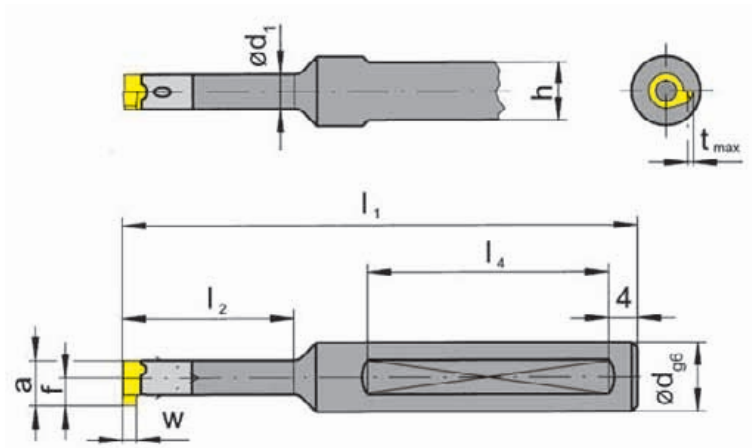
Abmessungen in mm
Dimensions in mm

Bestellhinweis:

Klemmhalter sind jeweils für rechte und linke Schneidplatten verwendbar.

Klemmhalter mit beschädigter Schneidplattenaufnahme können durch unseren Reparaturservice instand gesetzt werden.

Ordering note:

Toolholders can be used with right and left hand inserts. Toolholders with damaged seating can be repaired by HORN.

Das Anzugsdrehmoment der Schrauben finden Sie in den Technischen Hinweisen.

For torque specification of the screw, please see Technical Instructions.

Ersatzteile

Spare Parts

Klemmhalter Toolholder	Spannschraube Screw	TORX PLUS®-Schlüssel TORX PLUS® Wrench
B108...	2.6.5T8EP	T8PL

R

Klemmhalter

Toolholder

B111

mit innerer Kühlmittelzufuhr
with through coolant supply

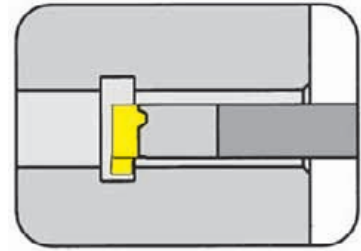

Bohrungs-Ø ab	Bore Ø from	11 mm
Stechtiefe bis	Depth of groove up to	2,3 mm
Stechbreite bis	Width of groove up to	3 mm

Schaftmaterial: Hartmetall (schwingungsarm)
Material of shank: Carbide - Giving a good vibration resistance

Schneidplatte
Insert

Typ 111
Type S111



Abbildung = rechtsschneidend
Picture = right hand cutting version

Bestellnummer Part number	d	l ₁	h	l ₄	d ₁
B111.0008.01	8	80	7	55	8

Weitere Abmessungen auf Anfrage
Further sizes upon request

w, a, tmax und f siehe Schneidplatten
w, a, tmax and f see inserts

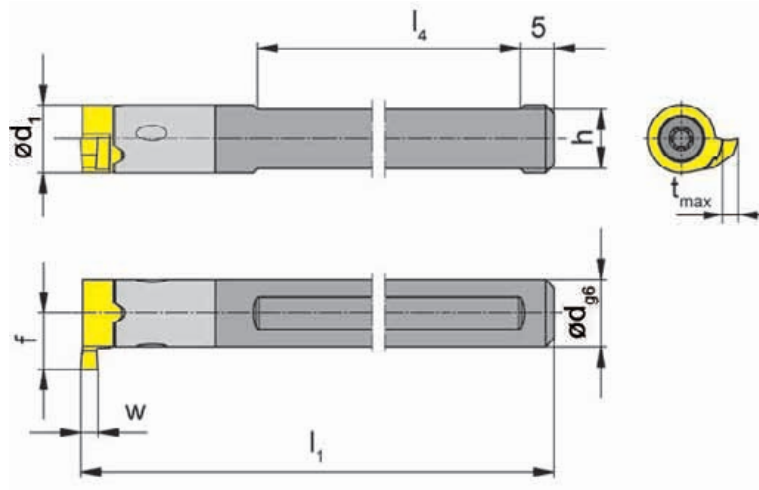
Abmessungen in mm
Dimensions in mm

Bestellhinweis:

Klemmhalter sind jeweils für rechte und linke Schneidplatten verwendbar.
Klemmhalter mit beschädigter Schneidplattenaufnahme können durch unseren Reparaturservice instand gesetzt werden.

Ordering note:

Toolholders can be used with right and left hand inserts. Toolholders with damaged seating can be repaired by HORN.

Das Anzugsdrehmoment der Schrauben finden Sie in den Technischen Hinweisen.
For torque specification of the screw, please see Technical Instructions.

Ersatzteile

Spare Parts

Klemmhalter Toolholder	Spannschraube Screw	TORX PLUS®-Schlüssel TORX PLUS® Wrench
B111.0008.01	3.5.12T10EP	T10PL

Einstechen und Abstechen

Grooving and Parting Off



Klemmhalter

Toolholder

H100

mit Schraubklemmung
with screwed clamping

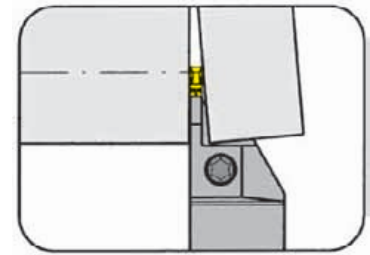

Stechtiefe bis Stechbreite	Depth of groove up to Width of groove	17 mm 2-3 mm
-------------------------------	--	-----------------

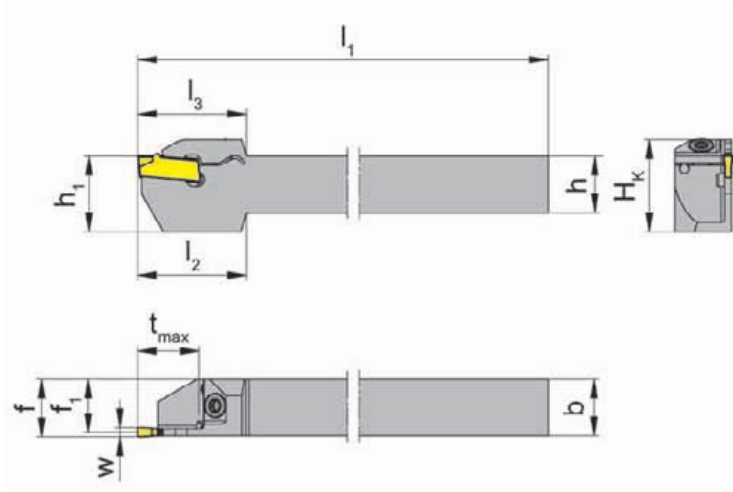

Schneidplatte
Insert

Typ S100
Type

R

für Langdrehautomaten
for Swiss type machines

R = rechts wie gezeichnet
R = right hand version shown

L = links spiegelbildlich
L = left hand version

Bestellnummer Part number	h	b	l ₁	l ₂	l ₃	h ₁	f ₁	f	t _{max}	D _{max}	H _k	Größe Size
R/LH100.1212.24.61	12	12	125	23	23	12	11,25	f ₁ +w/2	13	26	19,5	02
R/LH100.1212.32.63	12	12	125	27	24	12	10,85	f ₁ +w/2	17	34	19,5	03
R/LH100.1616.24.61	16	16	125	23	-	16	15,25	f ₁ +w/2	13	26	19,5	02
R/LH100.1616.32.63	16	16	125	27	-	16	14,85	f ₁ +w/2	17	34	19,5	03

Ausführung R oder L angeben
State R or L version

w siehe Schneidplatten
w see inserts

Abmessungen in mm
Dimensions in mm

Weitere Abmessungen auf Anfrage
Further sizes upon request

Das Anzugsdrehmoment der Schrauben finden Sie in den Technischen Hinweisen.
For torque specification of the screw, please see Technical Instructions.

Ersatzteile

Spare Parts

Klemmhalter Toolholder	Spannschraube Screw	TORX PLUS®-Schlüssel TORX PLUS® Wrench
R/LH100...	3.5.12T10EP	T10PL

Einstechen und Abstechen

Grooving and Parting Off



Klemmhalter

Toolholder

H264

mit Schraubklemmung
with screwed clamping

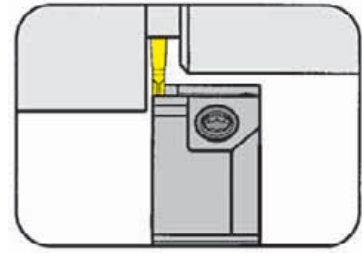

Stechtiefe bis Stechbreite	Depth of groove up to Width of groove	16 mm 1,5-2 mm
-------------------------------	--	-------------------

Wendeschneidplatte
Indexable insert

Typ 264
Type S264

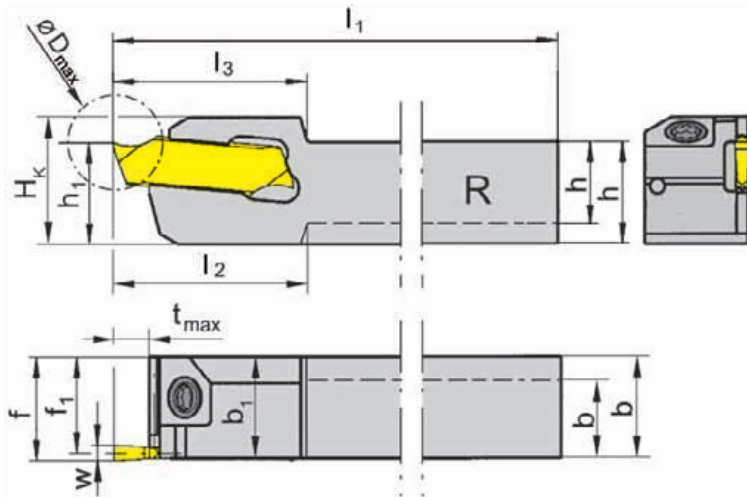

R = rechts wie gezeichnet
R = right hand version shown

L = links spiegelbildlich
L = left hand version

Bestellnummer Part number	h	b	l ₁	l ₂	l ₃	h ₁	b ₁	f ₁	f	t _{max}	D _{max}	H _k	Größe Size
R/LH264.0808.01	8	10	120	17,5	17,5	8	10	9,25	10	4	22	12,5	01
R/LH264.1010.01	10	10	120	-	17,5	10	-	9,25	10	4	22	12,5	01
R/LH264.1212.01	12	12	120	-	17,5	12	-	11,25	12	4	22	14,5	01
R/LH264.1616.01	16	16	120	-	17,5	16	-	15,25	16	4	32	18,5	01
R/LH264.1010.11	10	10	120	-	19,0	10	-	9,25	10	10	20	12,5	01
R/LH264.1212.11	12	12	120	-	19,0	12	-	11,25	12	10	20	14,5	01
R/LH264.1616.11	16	16	120	-	19,0	16	-	15,25	16	10	32	18,5	01
R/LH264.1212.21	12	12	120	-	22,0	12	-	11,25	12	13	26	15,5	01
R/LH264.1616.21	16	16	120	-	22,0	16	-	15,25	16	13	32	19,5	01
R/LH264.1010.02	10	10	120	-	17,5	10	-	9,00	10	4	32	12,5	02
R/LH264.1212.02	12	12	120	-	17,5	12	-	11,00	12	4	32	14,5	02
R/LH264.1616.02	16	16	120	-	17,5	16	-	15,00	16	4	32	18,5	02
R/LH264.1010.12	10	10	120	-	19,0	10	-	9,00	10	10	32	12,5	02
R/LH264.1212.12	12	12	120	-	19,0	12	-	11,00	12	10	32	14,5	02
R/LH264.1616.12	16	16	120	-	19,0	16	-	15,00	16	10	32	18,5	02
R/LH264.1212.22	12	12	120	-	25,0	12	-	11,00	12	16	32	14,5	02
R/LH264.1616.22	16	16	120	-	25,0	16	-	15,00	16	16	32	19,5	02

Ausführung R oder L angeben
State R or L version

w siehe Schneidplatten
w see inserts

Weitere Abmessungen auf Anfrage
Further sizes upon request

Abmessungen in mm
Dimensions in mm

Das Anzugsdrehmoment der Schrauben finden Sie in den Technischen Hinweisen.
For torque specification of the screw, please see Technical Instructions.

Ersatzteile

Spare Parts

Klemmhalter Toolholder	Spannschraube Screw	TORX PLUS®-Schlüssel TORX PLUS® Wrench
R/LH264...	3.5.12T10EP	T10PL

Einstechen und Abstechen

Grooving and Parting Off



Klemmhalter

Toolholder

H264

mit Schraubklemmung
with screwed clamping

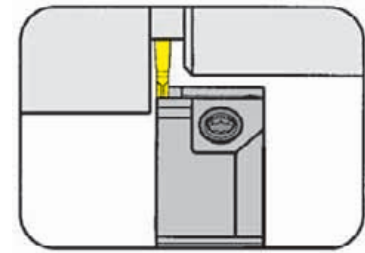

Stechtiefe bis Stechbreite	Depth of groove up to Width of groove	16 mm 2,5 mm
-------------------------------	--	-----------------

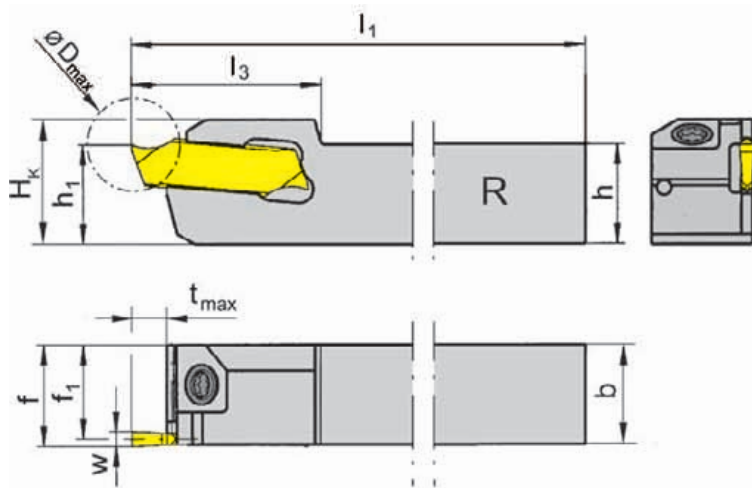

Wendeschneidplatte
Indexable insert

Typ 264
Type S264

R = rechts wie gezeichnet
R = right hand version shown

L = links spiegelbildlich
L = left hand version

Bestellnummer Part number	h	b	l ₁	l ₃	h ₁	f ₁	f	t _{max}	D _{max}	H _k	Größe Size
R/LH264.1212.03	12	12	120	17,5	12	10,75	12	4	32	14,5	03
R/LH264.1616.03	16	16	120	17,5	16	14,75	16	4	32	18,5	03
R/LH264.1212.13	12	12	120	19,0	12	10,75	12	10	32	14,5	03
R/LH264.1616.13	16	16	120	19,0	16	14,75	16	10	32	18,5	03
R/LH264.1212.23	12	12	120	25,0	12	10,75	12	16	32	14,5	03
R/LH264.1616.23	16	16	120	25,0	16	14,75	16	16	32	18,5	03

Ausführung R oder L angeben
State R or L version

w siehe Schneidplatten
w see inserts

Abmessungen in mm
Dimensions in mm

Weitere Abmessungen auf Anfrage
Further sizes upon request

Das Anzugsdrehmoment der Schrauben finden Sie in den Technischen Hinweisen.
For torque specification of the screw, please see Technical Instructions.

Ersatzteile

Spare Parts

Klemmhalter Toolholder	Spannschraube Screw	TORX PLUS®-Schlüssel TORX PLUS® Wrench
R/LH264...	3.5.12T10EP	T10PL



Einstechen und Abstechen

Grooving and Parting Off



Klemmhalter

Toolholder

H264

mit Schraubklemmung
with screwed clamping

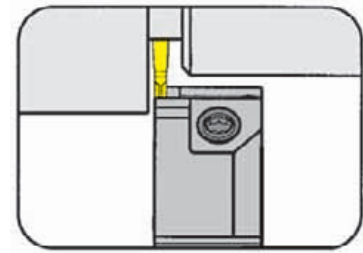

Stechtiefe bis Stechbreite	Depth of groove up to Width of groove	16 mm 3 mm
-------------------------------	--	---------------

Wendeschneidplatte
Indexable insert

Typ 264
Type S264

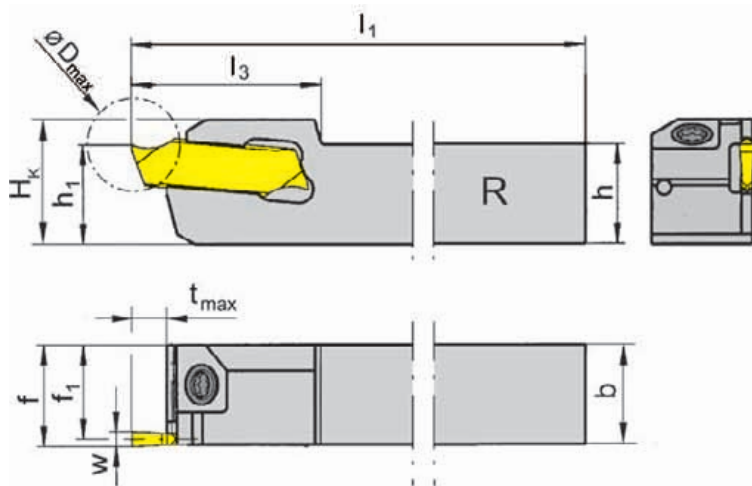

R = rechts wie gezeichnet
R = right hand version shown

L = links spiegelbildlich
L = left hand version

Bestellnummer Part number	h	b	l ₁	l ₃	h ₁	f ₁	f	t _{max}	D _{max}	H _K	Größe Size
R/LH264.1212.04	12	12	120	17,5	12	10,5	12	5	32	15	04
R/LH264.1616.04	16	16	120	17,5	16	14,5	16	5	32	19	04
R/LH264.1212.14	12	12	120	19,0	12	10,5	12	10	32	15	04
R/LH264.1616.14	16	16	120	19,0	16	14,5	16	10	32	19	04
R/LH264.1212.24	12	12	120	25,0	12	10,5	12	16	32	15	04
R/LH264.1616.24	16	16	120	25,0	16	14,5	16	16	32	19	04

Ausführung R oder L angeben
State R or L version

w siehe Schneidplatten
w see inserts

Abmessungen in mm
Dimensions in mm

Weitere Abmessungen auf Anfrage
Further sizes upon request

Das Anzugsdrehmoment der Schrauben finden Sie in den Technischen Hinweisen.
For torque specification of the screw, please see Technical Instructions.

Ersatzteile

Spare Parts

Klemmhalter Toolholder	Spannschraube Screw	TORX PLUS®-Schlüssel TORX PLUS® Wrench
R/LH264...	3.5.12T10EP	T10PL

Einstechen und Abstechen

Grooving and Parting Off



Klemmhalter

Toolholder

H264

mit Selbstklemmung
with self clamping

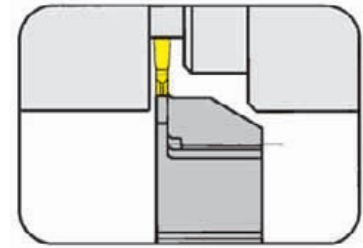

Stechtiefe bis Stechbreite	Depth of groove up to Width of groove	10 mm 1,5-3 mm
-------------------------------	--	-------------------

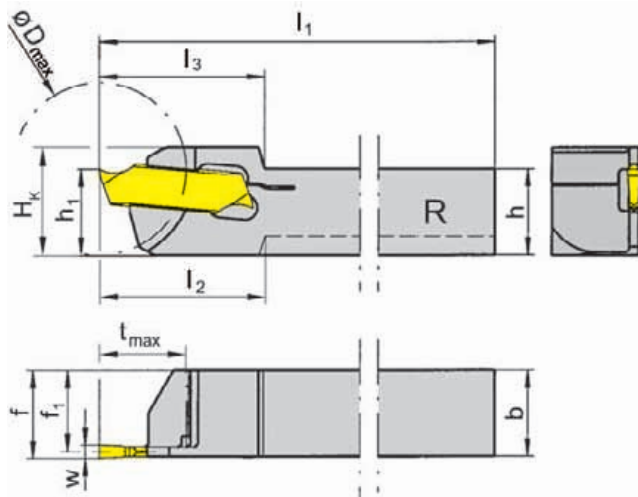

R = rechts wie gezeichnet
R = right hand version shown

L = links spiegelbildlich
L = left hand version

Wendeschneidplatte
Indexable insert

Typ 264
Type S264



Bestellnummer Part number	h	b	l ₁	l ₂	l ₃	h ₁	f ₁	f	t _{max}	D _{max}	H _k	Größe Size
R/LH264.0808.51	8	8	120	18	18	10	7,25	8	7	20	12,5	01
R/LH264.1010.61	10	10	120	-	19	10	9,25	10	10	20	12,5	01
R/LH264.1010.62	10	10	120	-	19	10	9,00	10	10	20	12,5	02
R/LH264.1212.62	12	12	120	-	19	12	11,00	12	10	20	14,5	02
R/LH264.1212.63	12	12	120	-	19	12	10,75	12	10	32	14,5	03
R/LH264.1212.64	12	12	120	-	19	12	10,50	12	10	32	14,5	04

Ausführung R oder L angeben
State R or L version

w siehe Schneidplatten
w see inserts

Abmessungen in mm
Dimensions in mm

Weitere Abmessungen auf Anfrage
Further sizes upon request

Hinweis:

Der Schlüssel **P39L** gehört nicht zum Lieferumfang des Schneidenträgers. Bitte separat bestellen!

Note:

Wrench **P39L** ist not combined with blade - separate order required!

Einstechen (außen)

Grooving (external)



Klemmhalter

Toolholder

248

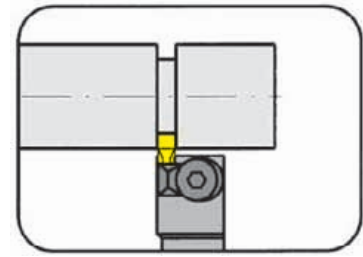

Stechtiefe bis Spannbereich	Depth of groove up to Clamping range	4 mm 0,5-2,7 mm
--------------------------------	---	--------------------

Wendeschneidplatte
Indexable insert

Typ 217
Type

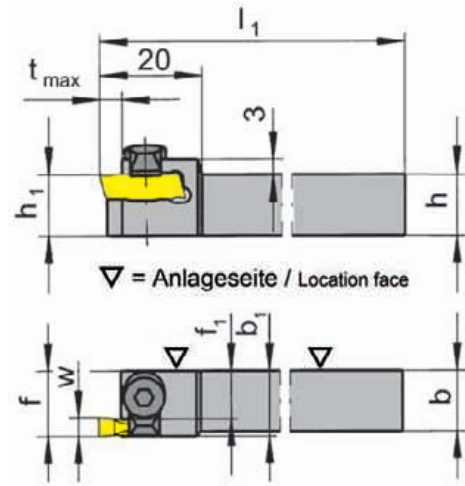

R = rechts wie gezeichnet
R = right hand version shown

L = links spiegelbildlich
L = left hand version

Bestellnummer Part number	h	b	f ₁	f	b ₁	t _{max}	l ₁	h ₁	Größe Size	Spannbereich Clamping range
R/L248.1212.01	12	12	1,5	f ₁ +a ₁	13	4	95	12	01	0,5-1,7
R/L248.1212.02	12	12	2,5	f ₁ +a ₁	13	4	95	12	02	1,7-2,7

Ausführung R oder L angeben
State R or L version

w, a₁ siehe WSP
w, a₁ see indexable inserts

Abmessungen in mm
Dimensions in mm

Weitere Abmessungen auf Anfrage
Further sizes upon request

Das Anzugsdrehmoment der Schrauben finden Sie in den Technischen Hinweisen.
For torque specification of the screw, please see Technical Instructions.

Ersatzteile

Spare Parts

Klemmhalter Toolholder	Inbus-Schlüssel Wrench	Spannelement Clamping element
R/L248...	SW2,5 DIN911	8.3

Einstecken und Längsdrehen

Grooving and Side Turning



Einbauhalter

Cartridge

KT274

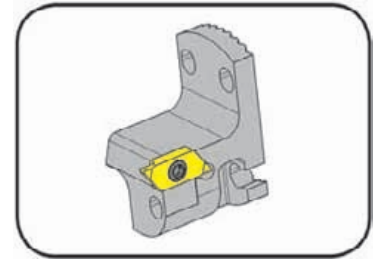

Stechtiefe bis
Stechbreite

Depth of groove up to
Width of groove

6 mm
0,5-3 mm

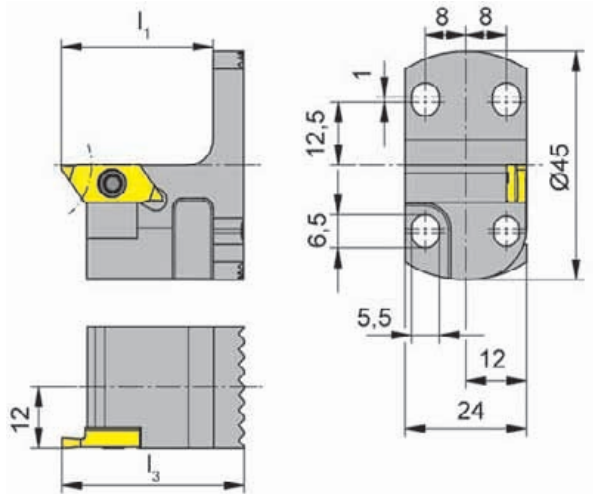

R = rechts wie gezeichnet
R = right hand version shown

L = links spiegelbildlich
L = left hand version

Wendeschneidplatte
Indexable insert

Typ S274
Type

R

Bestellnummer Part number	l_3	l_1	Größe Size
R/LKT274.2445.04	36	30	04

Ausführung R oder L angeben
State R or L version

Abmessungen in mm
Dimensions in mm

Weitere Abmessungen auf Anfrage
Further sizes upon request

Das Anzugsdrehmoment der Schrauben finden Sie in den Technischen Hinweisen.
For torque specification of the screw, please see Technical Instructions.

Ersatzteile

Spare Parts

Einbauhalter Cartridge	Schraube Screw	TORX PLUS®-Schlüssel TORX PLUS® Wrench
R/LKT274.2445.04	030.3509.T15P	T15PQ

Einstecken und Längsdrehen

Grooving and Side Turning



Einbauhalter

Cartridge

KTC274

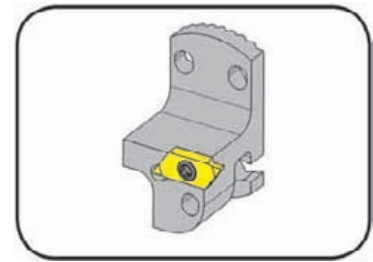

Stechtiefe bis
Stechbreite

Depth of groove up to
Width of groove

6 mm
0,5-3 mm

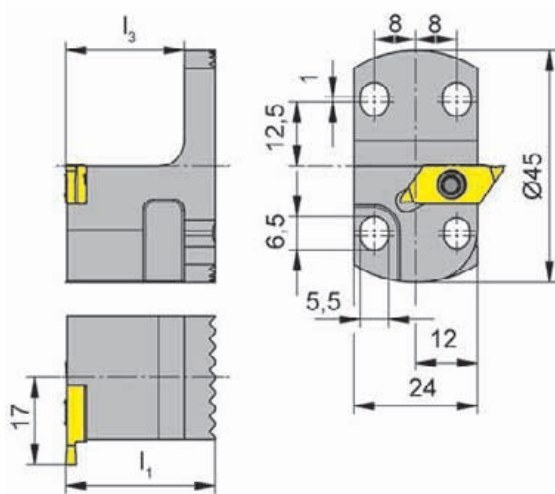

Wendeschneidplatte
Indexable insert

Typ S274
Type

R

R = rechts wie gezeichnet
R = right hand version shown

Bestellnummer Part number	l_1	l_3	Größe Size
RKTC274.2445.04	29	23	04

Weitere Abmessungen auf Anfrage
Further sizes upon request

Abmessungen in mm
Dimensions in mm

Bestellhinweis:

Linke Wendeschneidplatte für rechten Klemmhalter verwenden.

Ordering note:

Use left hand insert in right hand toolholder.

Das Anzugsdrehmoment der Schrauben finden Sie in den Technischen Hinweisen.

For torque specification of the screw, please see Technical Instructions.

Ersatzteile

Spare Parts

Einbauhalter Cartridge	Schraube Screw	TORX PLUS®-Schlüssel TORX PLUS® Wrench
RKTC274.2445.04	030.3509.T15P	T15PQ

Einstecken und Drehen

Grooving and Turning



Klemmhalter

Toolholder

H274

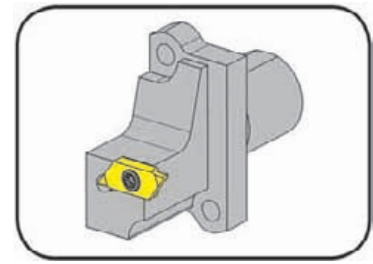

Stechtiefe bis
Stechbreite bis

Depth of groove up to
Width of groove up to

6 mm
7 mm

Lochbild 13,7 x 37,6 mm
Hole pattern 13,7 x 37,6 mm

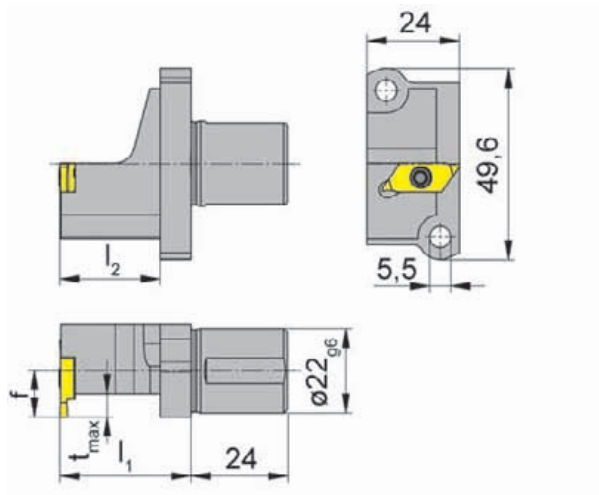

Wendeschneidplatte
Indexable insert

Typ S274.
Type

R

R = rechts wie gezeichnet
R = right hand version shown

L = links spiegelbildlich
L = left hand version

für Star
Langdrehautomaten
for Swiss type machines Star

Bestellnummer Part number	f	l ₁	t _{max}	l ₂	Größe Size
R/LH274.A022.09.04	9	34	6	26	04
R/LH274.A022.12.04	12	34	6	26	04
R/LH274.A022.16.04	16	34	6	26	04
R/LH274.A022.09.07	9	34	6	26	07
R/LH274.A022.12.07	12	34	6	26	07

Ausführung R oder L angeben
State R or L version

Abmessungen in mm
Dimensions in mm

Weitere Abmessungen auf Anfrage
Further sizes upon request

Bestellhinweis:

Rechte WSP in linken, linke WSP in rechten Klemmhaltern verwenden.

Ordering note:

Use right hand inserts in left hand toolholders and left hand inserts in right hand toolholders

Das Anzugsdrehmoment der Schrauben finden Sie in den Technischen Hinweisen.

For torque specification of the screw, please see Technical Instructions.

Ersatzteile

Spare Parts

Klemmhalter Toolholder	Spannschraube Screw	TORX PLUS®-Schlüssel TORX PLUS® Wrench
R/LH274...	030.3513.T15P	T15PQ

Einstechen und Längsdrehen (außen)

Grooving and Side Turning (external)



Klemmhalter

Toolholder

H224

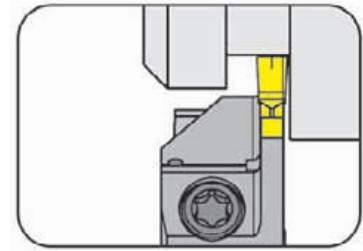

Stechtiefe bis
Spannbereich

Depth of groove up to
Clamping range

10,5 mm
2-3,7 mm

Wendeschneidplatte
Indexable insert

Typ S224
Type NS224

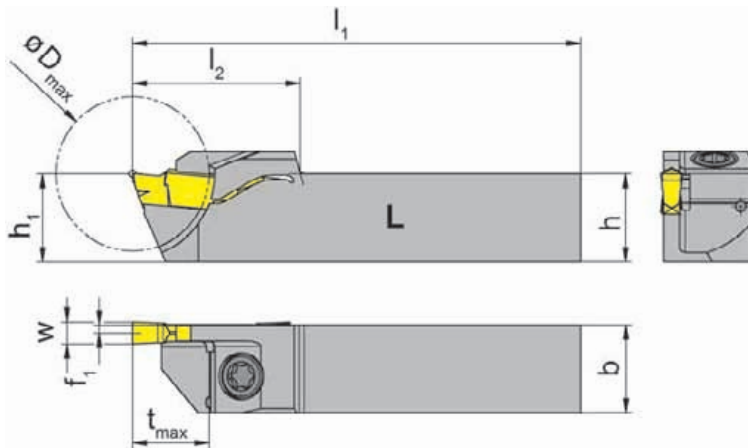

L = links wie gezeichnet
L = left hand version shown

R = rechts spiegelbildlich
R = right hand version

Bestellnummer Part number	h	b	l ₁	l ₂	h ₁	f ₁	t _{max}	D _{max}	Größe Size	Spannbereich Clamping range
R/LH224.1212.20.61	12	12	100	23	12	0,7	10,5	21	01	2,0-2,4
R/LH224.1212.20.62	12	12	100	23	12	0,9	10,5	21	02	2,4-2,8
R/LH224.1212.20.63	12	12	100	23	12	1,1	10,5	21	03	2,8-3,7

Ausführung R oder L angeben
State R or L version

w siehe WSP
w see indexable inserts

Abmessungen in mm
Dimensions in mm

Weitere Abmessungen auf Anfrage
Further sizes upon request

Das Anzugsdrehmoment der Schrauben finden Sie in den Technischen Hinweisen.
For torque specification of the screw, please see Technical Instructions.

Ersatzteile

Spare Parts

Klemmhalter Toolholder	Spannschraube Screw	TORX PLUS®-Schlüssel TORX PLUS® Wrench
R/LH224...	4.12T15EP	T15PQ

Einstecken und Längsdrehen (innen)

Grooving and Side Turning (internal)



Klemmhalter

Toolholder

H224

mit Schraubklemmung
with screwed clamping

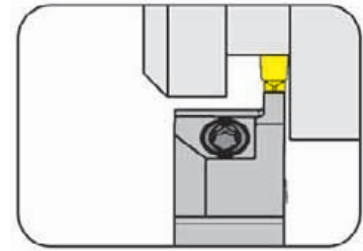

Stechtiefe bis
Spannbereich

Depth of groove up to
Clamping range

7 mm
2-6,1 mm

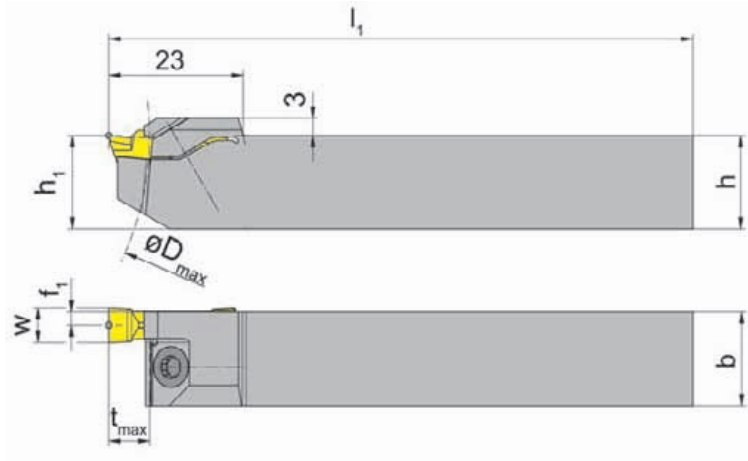

Wendeschneidplatte
Indexable insert

Typ S224
Type NS224

R

L = links wie gezeichnet
L = left hand version shown

R = rechts spiegelbildlich
R = right hand version

Bestellnummer Part number	h	b	l ₁	h ₁	f ₁	t _{max}	D _{max}	Größe Size	Spannbereich Clamping range
R/LH224.1212.61	12	12	100	12	0,70	7	100	01	2,0-2,4
R/LH224.1616.61	16	16	100	16	0,70	7	100	01	2,0-2,4
R/LH224.1212.62	12	12	100	12	0,90	7	100	02	2,4-2,8
R/LH224.1616.62	16	16	100	16	0,90	7	100	02	2,4-2,8
R/LH224.1212.63	12	12	100	12	1,10	7	100	03	2,8-3,7
R/LH224.1616.63	16	16	100	16	1,10	7	100	03	2,8-3,7
R/LH224.1212.64	12	12	100	12	1,45	7	100	04	3,7-4,4
R/LH224.1616.64	16	16	100	16	1,45	7	100	04	3,7-4,4
R/LH224.1616.65	16	16	100	16	1,85	7	100	05	4,4-5,1
R/LH224.1616.66	16	16	100	16	2,25	7	100	06	5,1-6,1

Ausführung R oder L angeben
State R or L version

w siehe WSP
w see indexable inserts

Abmessungen in mm
Dimensions in mm

Weitere Abmessungen auf Anfrage
Further sizes upon request

Das Anzugsdrehmoment der Schrauben finden Sie in den Technischen Hinweisen.
For torque specification of the screw, please see Technical Instructions.

Ersatzteile

Spare Parts

Klemmhalter Toolholder	Spannschraube Screw	TORX PLUS®-Schlüssel TORX PLUS® Wrench
R/LH224....	4.12T15EP	T15PL
R/LH224.1616....	5.13T20EP	T20PQ

Einstechen und Abstechen

Grooving and Parting Off



Klemmhalter

Toolholder

L368

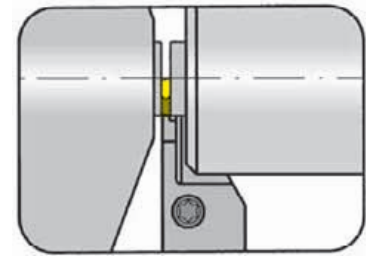

Stechtiefe bis Stechbreite	Depth of groove up to Width of groove	8 mm 0,5-1,5 mm
-------------------------------	--	--------------------

Werkzeug für Tornos
Tool for Tornos

für Wendeschneidplatte
for Indexable insert

Typ 312
Type

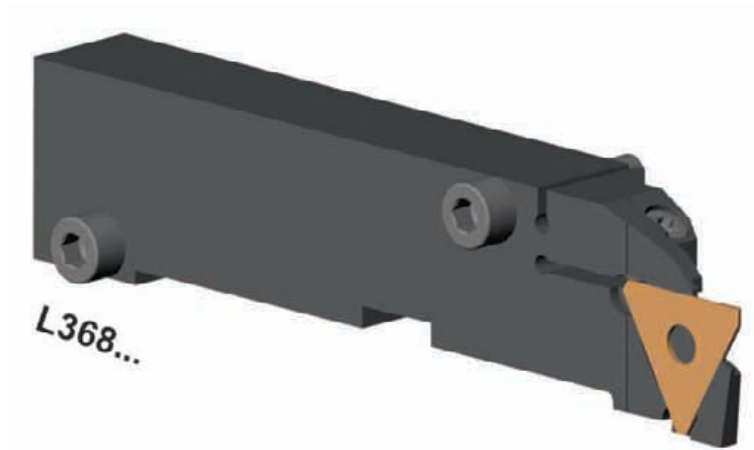

R

Bestellnummer Part number	t _{max}	w _{min}	w _{max}	Maschinentyp Machine type	Schneidplatte Insert
L368.0710.08	8	0,5	1,2	EvoDECO 10	R/L312.0805... R/L312.0808... R/L312.0510... R/L312.0512... R/L312.1012... 312.0012...
L368.0710.11	8	1,5	1,5	EvoDECO 10	R/L312.0515... 312.0015...

Weitere Abmessungen auf Anfrage
Further sizes upon request

Abmessungen in mm
Dimensions in mm

Das Anzugsdrehmoment der Schrauben finden Sie in den Technischen Hinweisen.
For torque specification of the screw, please see Technical Instructions.

Ersatzteile

Spare Parts

Klemmhalter Toolholder	Spannschraube Screw	Inbus-Schlüssel Wrench	TORX PLUS®-Schlüssel TORX PLUS® Wrench	Zylinderstift Straight pin
L368...	4.18T15EP	SW4,0 DIN911	T15PQ	020.0518.1610

Einstecken und Abstechen

Grooving and Parting Off



Grundhalter

Basic toolholder

L760

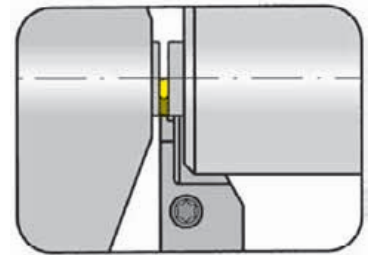

Stechtiefe bis Stechbreite	Depth of groove up to Width of groove	15 mm 0,5 - 3,7 mm
-------------------------------	--	-----------------------

Werkzeug für Tornos
Tool for Tornos

für Kassette
for Cassette

Typ LNK368
Type LNK760

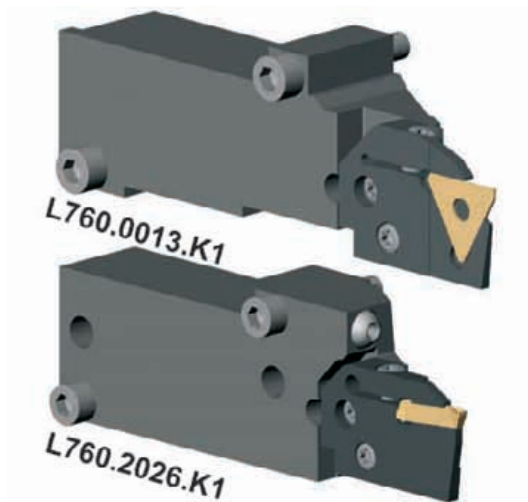

R

Bestellnummer Part number	t _{max}	w	Maschinentyp Machine type	Kassette Cassette	Schneidplatte Insert
L760.0013.K1	8	0,5 - 1,2	DECO13	LNK368.0760.08	R/L312.0805... R/L312.0808... R/L312.0510... R/L312.0512... R/L312.1210... 312.0012...
L760.0013.K1	8	1,5	DECO13	LNK368.0760.11	R/L312.0515... 312.0015...
L760.2026.K1	15	2,0 - 2,4 2,4 - 2,8 2,8 - 3,7	DECO20/26	LNK760.0224.01 LNK760.0224.02 LNK760.0224.03	S224...

Weitere Abmessungen auf Anfrage
Further sizes upon request

Abmessungen in mm
Dimensions in mm

Ersatzteile

Spare Parts

Grundhalter Basic toolholder	Inbus-Schlüssel Wrench
L760...	SW5,0 DIN911

Einstechen und Abstechen

Grooving and Parting Off



Kassette

Cassette

LNK368/LNK760

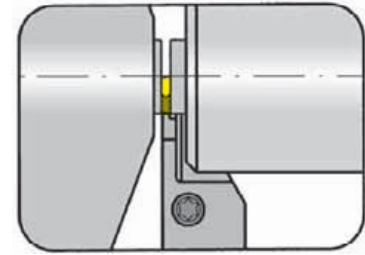

Stechtiefe bis Stechbreite	Depth of groove up to Width of groove	15 mm 0,5 - 3,7 mm
-------------------------------	--	-----------------------

Werkzeug für Tornos
Tool for Tornos

Wendeschneidplatte
Indexable insert

Typ 312
Type S224

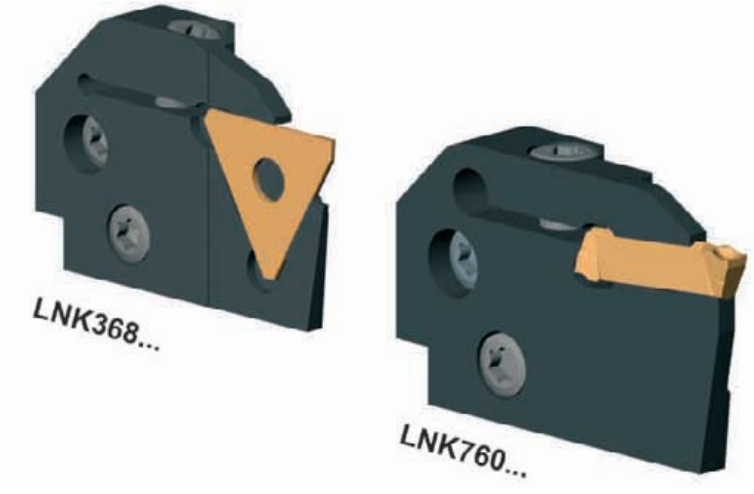

R

Bestellnummer Part number	t _{max}	W _{min}	W _{max}	Maschinentyp Machine type	Schneidplatte Insert
LNK368.0760.08	9	0,5	1,2	EvoDECO 16	R/L312.0805... R/L312.0808... R/L312.0510... R/L312.0512... R/L312.1210... 312.0012...
LNK368.0760.11	9	1,5	1,5	EvoDECO 16	R/L312.0515... 312.0015...
LNK760.0224.01	15	2,0	2,4	EvoDECO 20/EvoDECO 32	S224...
LNK760.0224.02	15	2,4	2,8	EvoDECO 20/EvoDECO 32	S224...
LNK760.0224.03	15	2,8	3,7	EvoDECO 20/EvoDECO 32	S224...

Weitere Abmessungen auf Anfrage
Further sizes upon request

Abmessungen in mm
Dimensions in mm

Das Anzugsdrehmoment der Schrauben finden Sie in den Technischen Hinweisen.
For torque specification of the screw, please see Technical Instructions.

Ersatzteile

Spare Parts

Kassette Cassette	Spannschraube Screw	TORX PLUS®-Schlüssel TORX PLUS® Wrench
LNK368.0760...	5.10T20P	T20PQ
LNK760.0224....	5.12T20P	T20PQ

Einstecken (außen)

Grooving (external)



Klemmhalter

Toolholder

361

verringerte Kopfgröße
reduced head size

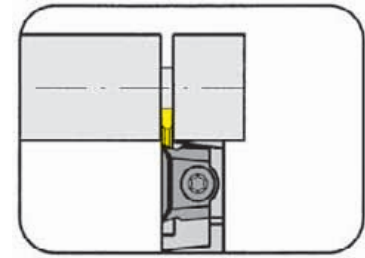

Stechtiefe bis Spannbereich	Depth of groove up to Clamping range	6 mm 0,5-3,9 mm
--------------------------------	---	--------------------

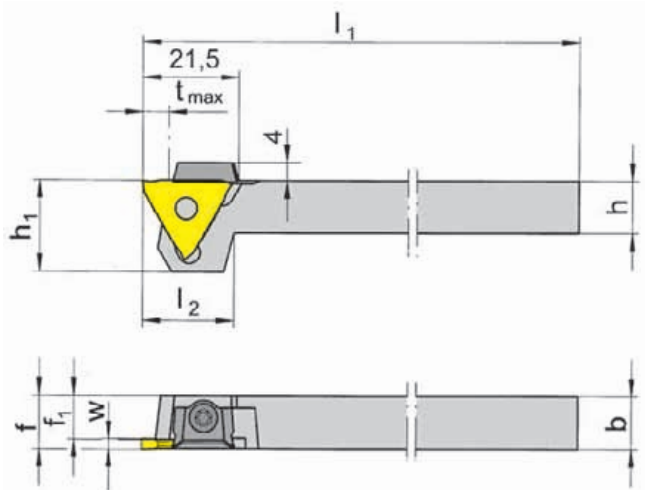

Wendeschneidplatte
Indexable insert

Typ 312
Type S312
N312

R

R = rechts wie gezeichnet
R = right hand version shown

L = links spiegelbildlich
L = left hand version

Bestellnummer Part number	h	b	l ₁	l ₂	h ₁	f ₁	f	t _{max}	Größe Size	Spannbereich Clamping range
R/L361.1212.01	12	12	100	17	19	10,5	f ₁ +w-a ₁	4	01	0,5-1,9
R/L361.1212.02	12	12	100	17	19	9,5	f ₁ +w-a ₁	6	02	1,9-2,9
R/L361.1212.03	12	12	100	21	21	8,5	f ₁ +w-a ₁	6	03	2,9-3,9

Ausführung R oder L angeben
State R or L version

w, a₁ siehe WSP
w, a₁ see indexable inserts

Abmessungen in mm
Dimensions in mm

Weitere Abmessungen auf Anfrage
Further sizes upon request

t_{max} nur bei Werkstück-Ø ≤ 40 mm erreichbar.
t_{max} can be reached only with workpiece Ø ≤ 40 mm

Das Anzugsdrehmoment der Schrauben finden Sie in den Technischen Hinweisen.
For torque specification of the screw, please see Technical Instructions.

Ersatzteile

Spare Parts

Klemmhalter Toolholder	Spannelement Clamping element	TORX PLUS®-Schlüssel TORX PLUS® Wrench
R/L361...	12.3	T10PL

Abstechen

Parting Off



Klemmhalter

Toolholder

368

Stechtiefe bis Stechbreite	Depth of groove up to Width of groove	8 mm 0,5-1,5 mm
-------------------------------	--	--------------------

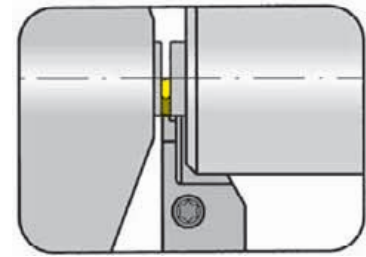

für TRAUB-Maschinen (TNL12/7)
for machines TRAUB (TNL12/7)

Wendeschneidplatte
Indexable insert

Typ 312 „G“
Type

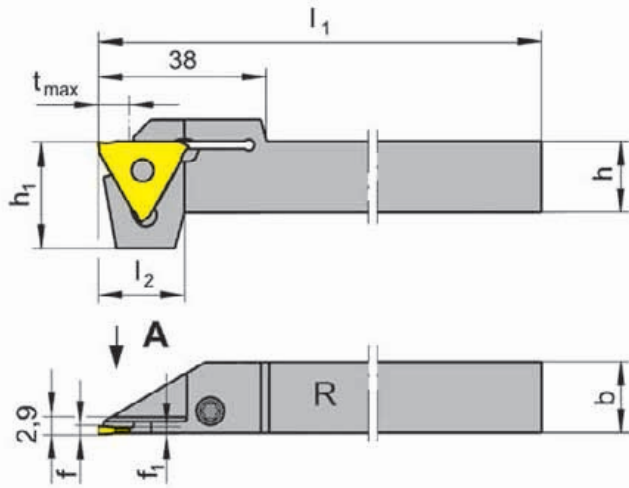
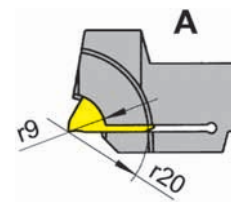

R = rechts wie gezeichnet
R = right hand version shown

L = links spiegelbildlich
L = left hand version

nur für umfangs-
geschliffene Form-WSP
only for periferal grounded
profiled inserts

Bestellnummer Part number	h	b	l ₁	l ₂	h ₁	f ₁	f	t _{max}
R/L368.1212.08	12	12	95	19,5	24	1,0	f ₁ +a ₁	8
R/L368.1616.08	16	16	95	19,5	24	1,0	f ₁ +a ₁	8
R/L368.1212.11	12	12	95	19,5	24	1,3	f ₁ +a ₁	8
R/L368.1616.11	16	16	95	19,5	24	1,3	f ₁ +a ₁	8

Ausführung R oder L angeben
State R or L version

a₁ siehe WSP
a₁ see indexable inserts

Abmessungen in mm
Dimensions in mm

Halter R/L368...08 für WSP:

R/L312.0805... / R/L312.0808... / R/L312.0510... R/L312.0512... / R/L312.1210... / R/L312.0012...

Toolholder R/L368...08 for indexable inserts:

R/L312.0805... / R/L312.0808... / R/L312.0510... R/L312.0512... / R/L312.1210... / R/L312.0012...

Halter R/L368...11 für WSP:

R/L312.0515... / R/L312.0015...

Toolholder R/L368...11 for indexable inserts:

R/L312.0515... / R/L312.0015...

Das Anzugsdrehmoment der Schrauben finden Sie in den Technischen Hinweisen.

For torque specification of the screw, please see Technical Instructions.

Ersatzteile

Spare Parts

Klemmhalter Toolholder	Spannschraube Screw	TORX PLUS®-Schlüssel TORX PLUS® Wrench
R/L368...	4.15T15P	T15PQ

Einstecken und Drehen

Grooving and Turning



Klemmhalter

Toolholder

369

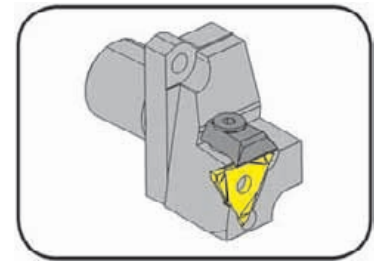

Stechtiefe Spannbereich	Depth of groove Clamping range	4-6 mm 0,5-2,9 mm
----------------------------	-----------------------------------	----------------------

Lochbild 13,7 x 37,6 mm
Hole pattern 13,7 x 37,6 mm

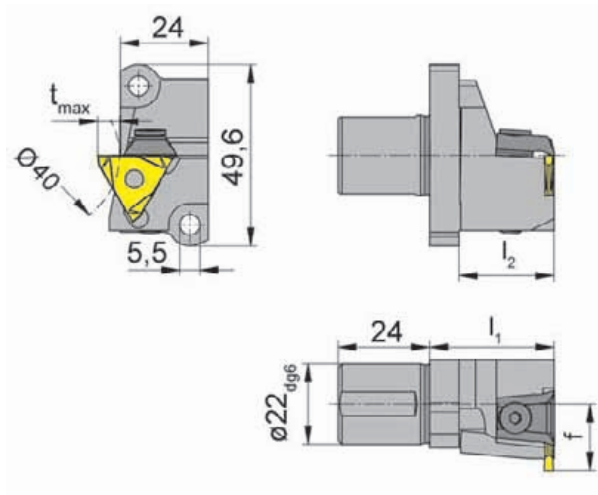

Wendeschneidplatte
Indexable insert

Typ 312
Type



für Star
Langdrehautomaten
for Swiss type machines Star

L = links wie gezeichnet
L = left hand version shown

Bestellnummer Part number	l_2	f	t_{max}	l_1	Größe Size	Spannbereich Clamping range
L369.A022.18.01	26	18,2	4	34	01	0,5-1,9
L369.A022.18.02	26	18,2	6	34	02	1,9-2,9

Weitere Abmessungen auf Anfrage
Further sizes upon request

Abmessungen in mm
Dimensions in mm

Das Anzugsdrehmoment der Schrauben finden Sie in den Technischen Hinweisen.
For torque specification of the screw, please see Technical Instructions.

Star Langdrehautomaten: ECAS-12/20, SB16D/E, SR-20, SR20J/JN, RS-20RII, RS-20RIII, RS-20RIV, RS-32J/JN, SW-12RIII

Swiss Type Machines Star: ECAS-12/20, SB16D/E, SR-20, SR20J/JN, RS-20RII, RS-20RIII, RS-20RIV, RS-32J/JN, SW-12RII

Ersatzteile

Spare Parts

Klemmhalter Toolholder	Inbus-Schlüssel Wrench	Spannelement Clamping element
L369...	SW3,0 DIN911	16.4

R





System	Seite/page
105	S2
110	S16
114	S22
25A und 15A	S34
224	S44
229	S62
231	S90
312	S96
A315	S102

Axialeinstechen

Face Grooving

Klemmhalter
Toolholder
B105/BU105

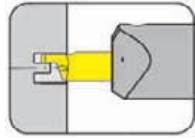

Seite/Page
S4-S5

Klemmhalter
Toolholder
H105/HC105/VDI

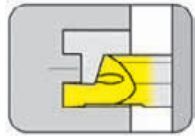

Seite/Page
S6-S8

Schneidplatte
Insert
105/A105

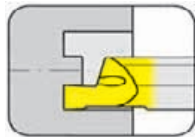

Seite/Page
S9-S13

Klemmhalter
Toolholder
B105

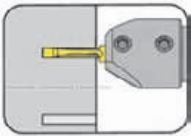

Seite/Page
S14

Schneidplatte
Insert
A105

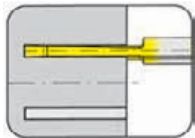

Seite/Page
S15

S

105



**Klemmhalter mit
Schneidplatten**

Stechbreite 2,0 - 3,0 mm

**Toolholder with
Inserts**

Width of groove 2,0 - 3,0 mm

Axialeinstechen

Face Grooving



Klemmhalter

Toolholder

B105

mit innerer Kühlmittelzufuhr
with through coolant supply

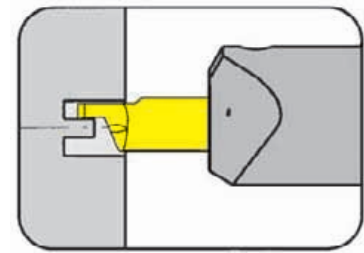

Nutaußen-Ø ab	from outer groove Ø	5,0 mm
Stechtiefe	Depth of groove	6,0 mm
Stechbreite bis	Width of groove up to	2,0 mm

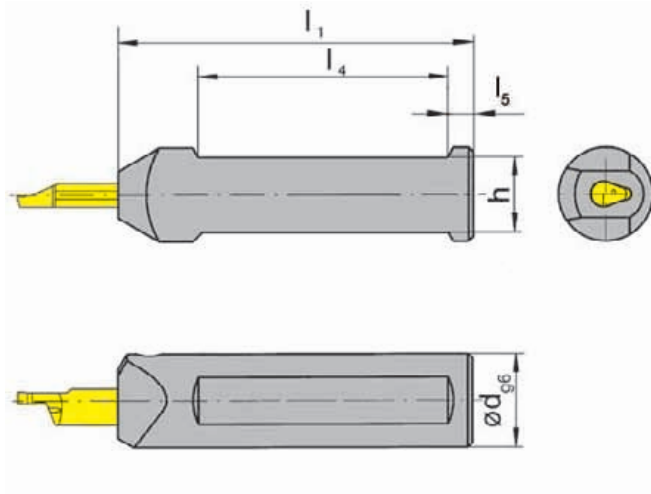

Schneidplatte
Insert

Typ 105
Type

Abbildung = linksschneidend
Picture = left hand cutting version

Bestellnummer Part number	d	l ₁	h	l ₄
B105.0010.01	10	75	9	50
B105.0012.01	12	75	11	50
B105.0016.01	16	75	14	50
B105.0020.01	20	90	18	55
B105.0025.01	25	100	23	55

Weitere Abmessungen auf Anfrage
Further sizes upon request

Abmessungen in mm
Dimensions in mm

Bestellhinweis:

Klemmhalter sind jeweils für rechte und linke Schneidplatten verwendbar.

Ordering note:

Toolholders can be used with right and left hand inserts.

Das Anzugsdrehmoment der Schrauben finden Sie in den Technischen Hinweisen.

For torque specification of the screw, please see Technical Instructions.

Ersatzteile

Spare Parts

Klemmhalter Toolholder	Spannschraube Screw	TORX PLUS®-Schlüssel TORX PLUS® Wrench
B105...	6.075T15P	T15PQ

Axialeinstechen

Face Grooving



Klemmhalter

Toolholder

B105/BU105

mit innerer Kühlmittelzufuhr
with through coolant supply

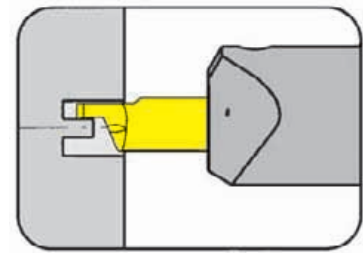

Nutaußen-Ø ab	from outer groove Ø	5,0 mm
Stechtiefe bis	Depth of groove up to	6,0 mm
Stechbreite bis	Width of groove up to	2,0 mm

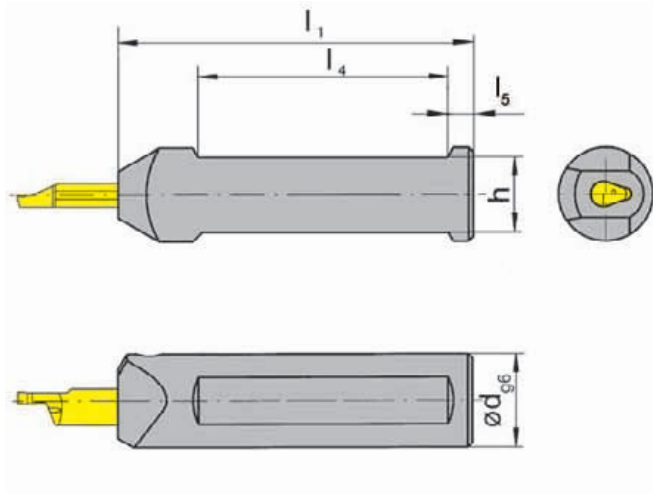

Schneidplatte
Insert

Typ 105
Type

Abbildung = rechtsschneidend
Picture = right hand cutting version

Bestellnummer Part number	d	l ₁	h	l ₄	l ₅
B105.0022.01	22,00	90	20,00	55	5
B105.0028.01**	28,00	120	26,00	72	12
BU105.0750.5.01**	3/4"	90	17,04	70	5
BU105.1000.5.01**	1"	90	23,40	65	5

Weitere Abmessungen auf Anfrage
Further sizes upon request

Abmessungen in mm
Dimensions in mm

** Kühlmittelanschluss M12x1,5 Der Kühlmittelanschluss gehört nicht zum Lieferumfang. Bitte separat bestellen!
** Adapter of cooling M12x1,5 Coolant supply must be ordered separately!

Bestellhinweis:

Klemmhalter sind jeweils für rechte und linke Schneidplatten verwendbar.

Ordering note:

Toolholders can be used with right and left hand inserts.

Das Anzugsdrehmoment der Schrauben finden Sie in den Technischen Hinweisen.
For torque specification of the screw, please see Technical Instructions.

Ersatzteile

Spare Parts

Klemmhalter Toolholder	Spannschraube Screw	TORX PLUS®-Schlüssel TORX PLUS® Wrench
B105...	6.075T15P	T15PQ

Axialeinstechen

Face Grooving



Klemmhalter

Toolholder

H105

mit Schraubklemmung
with screwed clamping

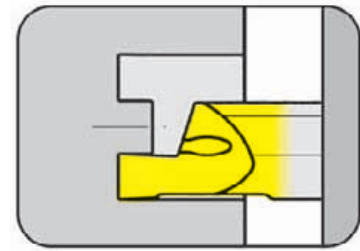

Nutaußen-Ø ab	from outer groove Ø	5,0 mm
Stechtiefe bis	Depth of groove up to	6,0 mm
Stechbreite bis	Width of groove up to	3,0 mm

mit innerer Kühlmittelzufuhr
with through coolant supply

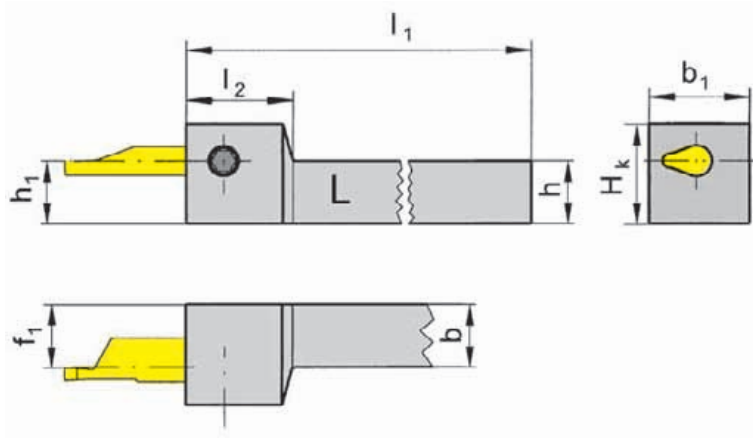

Schneidplatte
Insert

Typ 105
Type

L = links wie gezeichnet
L = left hand version shown

R = rechts spiegelbildlich
R = right hand version

Bestellnummer Part number	h	b	h ₁	b ₁	f ₁	H _k	l ₂	l ₁
R/LH105.0808.01	8	8	8	16	7,5	14	17	90
R/LH105.1010.01	10	10	10	16	7,5	16	17	90
R/LH105.1212.01	12	12	12	16	7,5	18	17	90
R/LH105.1616.01	16	16	16	16	7,5	22	17	110

Ausführung R oder L angeben
State R or L version

Abmessungen in mm
Dimensions in mm

Weitere Abmessungen auf Anfrage
Further sizes upon request

Das Anzugsdrehmoment der Schrauben finden Sie in den Technischen Hinweisen.
For torque specification of the screw, please see Technical Instructions.

Ersatzteile

Spare Parts

Klemmhalter Toolholder	Spannschraube Screw	TORX PLUS®-Schlüssel TORX PLUS® Wrench
R/LH105...	6.075T15P	T15PQ

Axialeinstechen

Face Grooving



Klemmhalter

Toolholder

HC105

mit Schraubklemmung
with screwed clamping

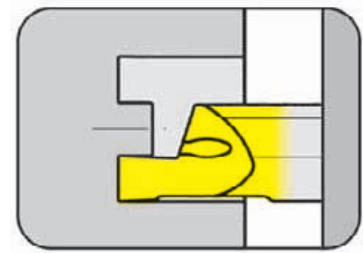

Nutaußen-Ø ab	from outer groove Ø	5,0 mm
Stechtiefe bis	Depth of groove up to	6,0 mm
Stechbreite bis	Width of groove up to	3,0 mm

Kühlmittelzufuhr über Winkelverschraubung
Coolant supply through cranked fitting

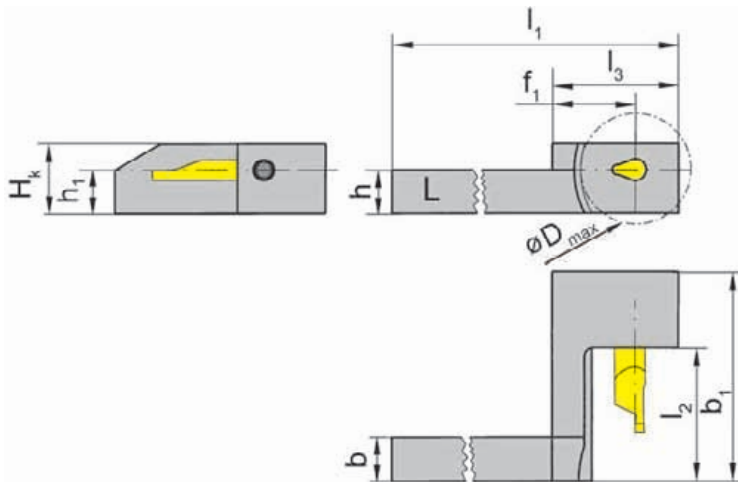

Schneidplatte
Insert

Typ 105
Type

L = links wie gezeichnet
L = left hand version shown

R = rechts spiegelbildlich
R = right hand version

Bestellnummer Part number	h	b	f ₁	H _k	b ₁	h ₁	D _{amax}	l ₁	l ₃	l ₂
R/LHC105.0707.21	7	7	19	13	32,0	7	26	99	29	18
R/LHC105.0808.21	8	8	19	13	32,0	8	26	99	29	18
R/LHC105.0812.21	8	12	19	13	32,0	8	26	99	29	18
RHC105.1010.11	10	10	19	16	22,7	10	26	99	29	8
R/LHC105.1010.21	10	10	19	16	38,0	10	26	99	29	18
R/LHC105.1010.41	10	10	19	16	48,0	10	26	99	29	28
R/LHC105.1212.21	12	12	19	18	38,0	12	26	99	29	18
R/LHC105.1212.41	12	12	19	18	48,0	12	26	99	29	28
R/LHC105.1616.21	16	16	24	22	38,0	16	36	104	34	18
R/LHC105.1616.41	16	16	24	22	48,0	16	36	104	34	28

Ausführung R oder L angeben
State R or L version

Weitere Abmessungen auf Anfrage
Further sizes upon request

Abmessungen in mm
Dimensions in mm

Hinweis:

R/LHC105.07.../08.../1010.11 ohne Innenkühlung

Note:

R/LHC105.07.../08.../1010.11 without trough coolant

Das Anzugsdrehmoment der Schrauben finden Sie in den Technischen Hinweisen.

For torque specification of the screw, please see Technical Instructions.

Ersatzteile

Spare Parts

Klemmhalter Toolholder	Spannschraube Screw	TORX PLUS®-Schlüssel TORX PLUS® Wrench	SMC Winkelverschraubung SMC angled screw coupling
R/LHC105...07/08/10	6.075T15P	T15PQ	-
R/LHC105....	6.075T15P	T15PQ	KQ2L06-M5

Axialeinstechen

Face Grooving



Klemmhalter

Toolholder

VDI

mit innerer Kühlmittelzufuhr
with through coolant supply

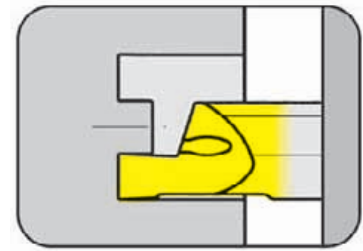

Nutaußen-Ø ab	from outer groove Ø	5,0 mm
Stechtiefe bis	Depth of groove up to	6,0 mm
Stechbreite bis	Width of groove up to	3,0 mm

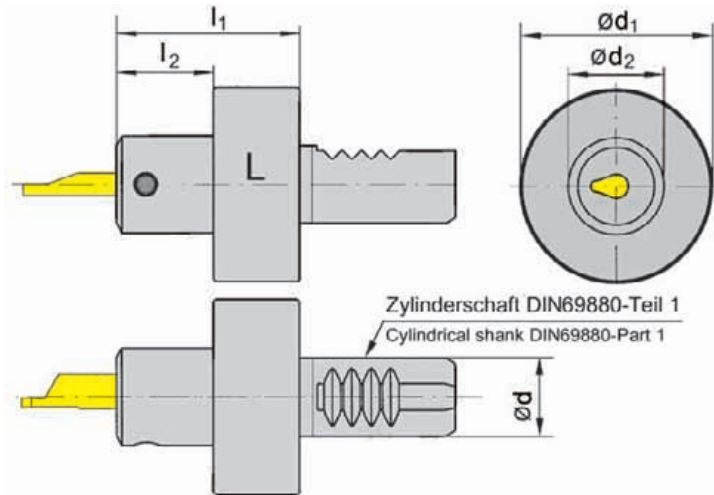

Schneidplatte
Insert

Typ 105
Type

L = links wie gezeichnet
L = left hand version shown

R = rechts spiegelbildlich
R = right hand version

Bestellnummer Part number	d	l ₁	l ₂	d ₂	d ₁
VDI16.L105.20.01	16	38	20	20	40
VDI16.R105.20.01	16	38	20	20	40
VDI20.L105.20.01	20	38	20	20	50
VDI20.R105.20.01	20	38	20	20	50
VDI25.L105.20.01	25	38	20	20	58
VDI25.R105.20.01	25	38	20	20	58
VDI30.L105.20.01	30	38	20	20	68
VDI30.R105.20.01	30	38	20	20	68
VDI40.L105.20.01	40	38	20	20	83
VDI40.R105.20.01	40	38	20	20	83

Ausführung R oder L angeben
State R or L version

Abmessungen in mm
Dimensions in mm

Weitere Abmessungen auf Anfrage
Further sizes upon request

Das Anzugsdrehmoment der Schrauben finden Sie in den Technischen Hinweisen.
For torque specification of the screw, please see Technical Instructions.

Ersatzteile

Spare Parts

Klemmhalter Toolholder	Spannschraube Screw	TORX PLUS®-Schlüssel TORX PLUS® Wrench
VDI16...	6.075T15P	T15PQ

Axialeinstechen

Face Grooving



Schneidplatte

Insert

105

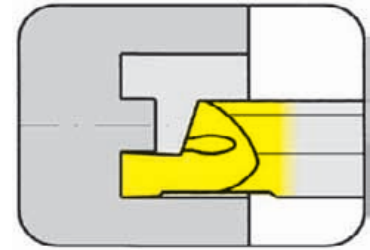

Nutaußen-Ø ab	from outer groove Ø	5 mm
Stechtiefe	Depth of groove	5 mm
Stechbreite bis	Width of groove up to	2 mm

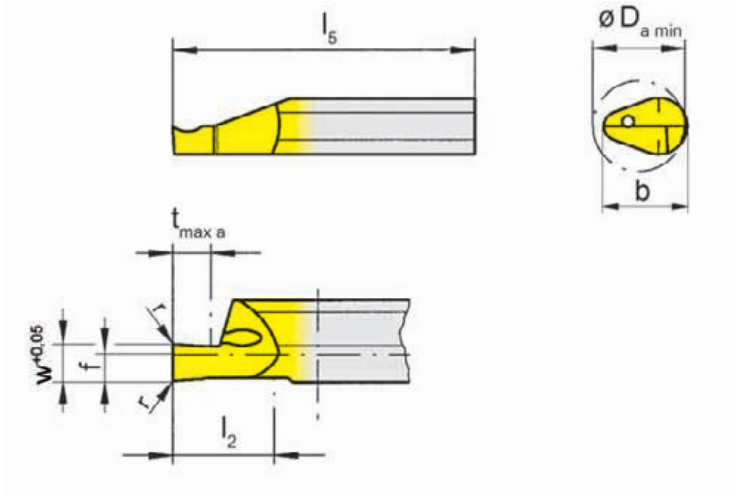

Klemmhalter
Toolholder

Typ H105
Type HC105
B105
VDI

R = rechts wie gezeichnet
R = right hand version shown

L = links spiegelbildlich
L = left hand version

Bestellnummer Part number	w	r	f	b	l ₂	l ₅	t _{max a}	D _{a min}	MG12	EG35	TI25
R/L105.0510.1.8	1,0	0,05	2	7	10	25	2	5	▲/Δ	▲/▲	▲/▲
R/L105.0515.1.8	1,5	0,05	2	7	10	25	3	5	▲/Δ	▲/▲	▲/▲
R/L105.0520.1.8	2,0	0,05	2	7	10	25	5	5	▲/Δ	▲/▲	▲/▲
R/L105.0510.2.8	1,0	0,05	2	7	15	35	2	5	Δ/Δ	▲/Δ	▲/▲
R/L105.0515.2.8	1,5	0,05	2	7	15	35	3	5	Δ/Δ	▲/▲	▲/▲
R/L/105.0520.2.8	2,0	0,05	2	7	15	35	5	5	Δ/▲	▲/▲	▲/▲

▲ ab Lager / on stock Δ 4 Wochen / 4 weeks x auf Anfrage / upon request

● empfohlen / recommended

o bedingt einsetzbar / alternative recommendation

- nicht geeignet / not suitable

■ unbeschichtete HM-Sorten / uncoated grades

■ beschichtete HM-Sorten / coated grades

■ bestückt/Cermet / brazed/Cermet

Abmessungen in mm

Dimensions in mm

Ausführung R oder L angeben

State R or L version

P	○	●	●
M	●	●	●
K	●	○	●
N	●	-	●
S	●	-	●
H	-	-	-

HM-Sorten
Carbide grades



Axialeinstechen

Face Grooving



Schneidplatte

Insert

105

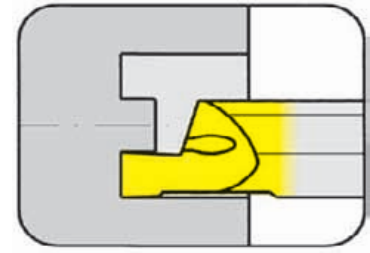

Nutaußen-Ø ab	from outer groove Ø	6 mm
Stechtiefe	Depth of groove	5 mm
Stechbreite bis	Width of groove up to	2 mm

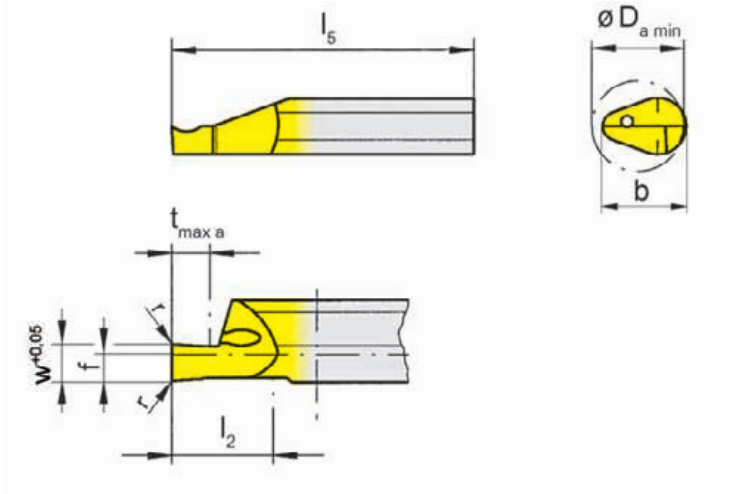

Klemmhalter
Toolholder

Typ H105
Type HC105
B105
VDI

R = rechts wie gezeichnet
R = right hand version shown

L = links spiegelbildlich
L = left hand version

Bestellnummer Part number	w	r	f	b	l ₂	l ₅	t _{max a}	D _{a min}	MG12	EG35	TI25
R/L105.0610.1.8	1,0	0,05	2	7	10	25	2	6	▲/Δ	▲/▲	▲/▲
R/L105.0615.1.8	1,5	0,05	2	7	10	25	3	6	▲/Δ	▲/▲	▲/▲
R/L105.0620.1.8	2,0	0,05	2	7	10	25	5	6	▲/Δ	▲/▲	▲/▲
R/L105.0610.2.8	1,0	0,05	2	7	15	35	2	6	Δ/Δ	▲/Δ	▲/Δ
R/L105.0615.2.8	1,5	0,05	2	7	15	35	3	6	▲/Δ	▲/Δ	▲/▲
R/L105.0620.2.8	2,0	0,05	2	7	15	35	5	6	▲/Δ	▲/▲	▲/▲

▲ ab Lager / on stock Δ 4 Wochen / 4 weeks x auf Anfrage / upon request

● empfohlen / recommended

o bedingt einsetzbar / alternative recommendation

- nicht geeignet / not suitable

■ unbeschichtete HM-Sorten / uncoated grades

■ beschichtete HM-Sorten / coated grades

■ bestückt/Cermet / brazed/Cermet

Abmessungen in mm

Dimensions in mm

Ausführung R oder L angeben

State R or L version

P	○	●	●
M	●	●	●
K	●	○	●
N	●	-	●
S	●	-	●
H	-	-	-

HM-Sorten
Carbide grades

Axialeinstechen

Face Grooving



Schneidplatte

Insert

105

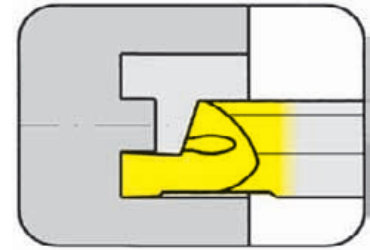

Nutaußen-Ø ab	from outer groove Ø	8 mm
Stechtiefe	Depth of groove	6 mm
Stechbreite bis	Width of groove up to	3 mm

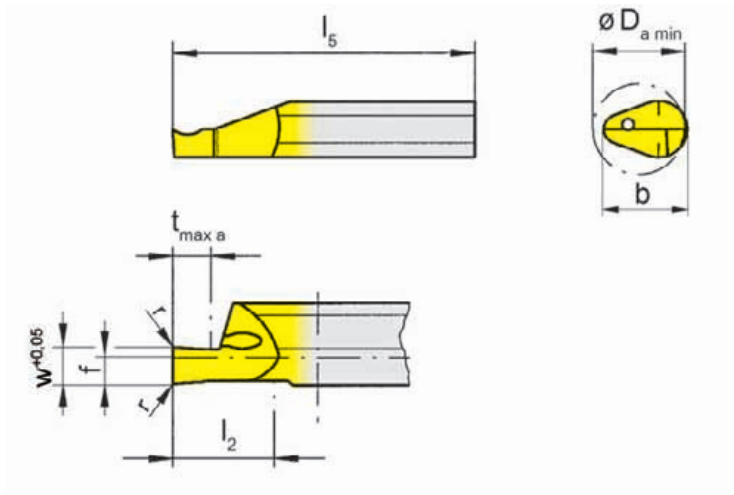

Klemmhalter
Toolholder

Typ H105
Type HC105
B105
VDI

R = rechts wie gezeichnet
R = right hand version shown

L = links spiegelbildlich
L = left hand version

Bestellnummer Part number	w	r	f	b	l ₂	l ₅	t _{max a}	D _{a min}	EG35	T125
R/L105.0810.1.8	1,0	0,15	2	7	10	25	2	8	▲/▲	▲/▲
R/L105.0815.1.8	1,5	0,15	2	7	10	25	3	8	▲/▲	▲/▲
R/L105.0820.1.8	2,0	0,15	2	7	10	25	4	8	▲/▲	▲/▲
R/L105.0825.1.8	2,5	0,15	2	7	10	25	5	8	▲/▲	▲/▲
R/L105.0830.1.8	3,0	0,15	2	7	10	25	6	8	▲/▲	▲/▲
R/L105.0810.2.8	1,0	0,15	2	7	15	35	2	8	▲/▲	▲/▲
R/L105.0815.2.8	1,5	0,15	2	7	15	35	3	8	▲/▲	▲/▲
R/L105.0820.2.8	2,0	0,15	2	7	15	35	4	8	▲/▲	▲/▲
R/L105.0825.2.8	2,5	0,15	2	7	15	35	5	8	▲/▲	▲/▲
R/L105.0830.2.8	3,0	0,15	2	7	15	35	6	8	▲/▲	▲/▲

▲ ab Lager / on stock Δ 4 Wochen / 4 weeks x auf Anfrage / upon request

● empfohlen / recommended

o bedingt einsetzbar / alternative recommendation

- nicht geeignet / not suitable

■ unbeschichtete HM-Sorten / uncoated grades

■ beschichtete HM-Sorten / coated grades

■ bestückt/Cermet / brazed/Cermet

Abmessungen in mm

Dimensions in mm

Ausführung R oder L angeben

State R or L version

P	•	•
M	•	•
K	o	•
N	-	•
S	-	•
H	-	-

HM-Sorten
Carbide grades



Axialeinstechen

Face Grooving



Schneidplatte

Insert

105

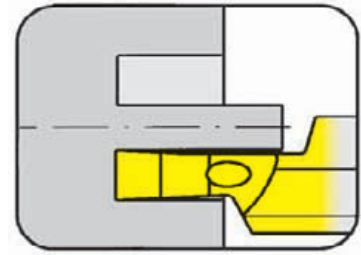

Nutaußen-Ø ab	from outer groove Ø	8 mm
Stechtiefe	Depth of groove	6 mm
Stechbreite bis	Width of groove up to	3 mm

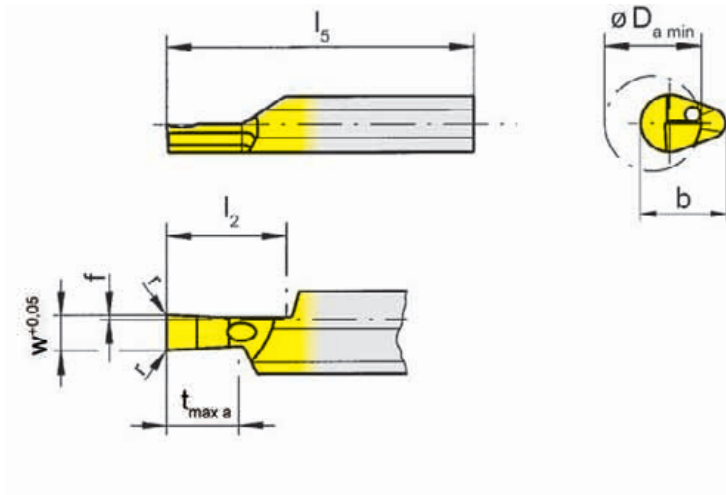

Klemhalter
Toolholder

Typ H105
Type HC105
B105
VDI

R = rechts wie gezeichnet
R = right hand version shown

L = links spiegelbildlich
L = left hand version

Bestellnummer Part number	w	r	f	b	l ₂	l ₅	t _{max a}	D _{a min}	EG35	Ti25
R/L105.0810.1.9	1,0	0,15	0,4	7	10	25	2	8	▲/▲	▲/▲
R/L105.0815.1.9	1,5	0,15	0,4	7	10	25	3	8	▲/▲	▲/▲
R/L105.0820.1.9	2,0	0,15	0,4	7	10	25	4	8	▲/▲	▲/▲
R/L105.0825.1.9	2,5	0,15	0,4	7	10	25	5	8	▲/▲	▲/▲
R/L105.0830.1.9	3,0	0,15	0,4	7	10	25	6	8	▲/▲	▲/▲

▲ ab Lager / on stock Δ 4 Wochen / 4 weeks x auf Anfrage / upon request

● empfohlen / recommended

o bedingt einsetzbar / alternative recommendation

- nicht geeignet / not suitable

■ unbeschichtete HM-Sorten / uncoated grades

■ beschichtete HM-Sorten / coated grades

■ bestückt/Cermet / brazed/Cermet

Abmessungen in mm

Dimensions in mm

Ausführung R oder L angeben

State R or L version

P	•	•
M	•	•
K	o	•
N	-	•
S	-	•
H	-	-

HM-Sorten
Carbide grades

Axialeinstechen

Face Grooving



Schneidplatte

Insert

105

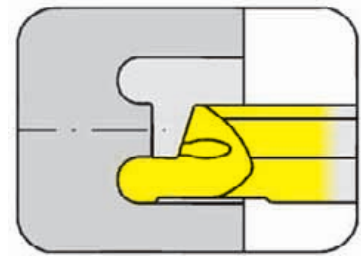

Nutaußen-Ø ab	from outer groove Ø	8 mm
Stechtiefe	Depth of groove	6 mm
Stechbreite bis	Width of groove up to	3 mm

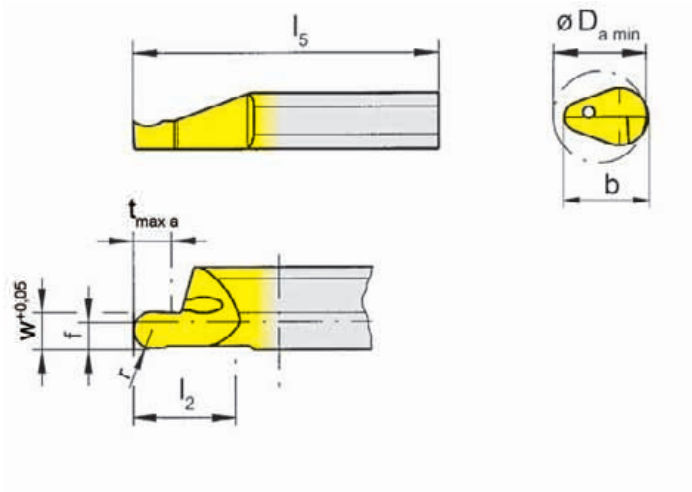

Klemmhalter
Toolholder

Typ H105
Type HC105
B105
VDI

R = rechts wie gezeichnet
R = right hand version shown

L = links spiegelbildlich
L = left hand version

Vollradius
Full radius

Bestellnummer Part number	w	r	f	b	l ₂	l ₅	t _{max a}	D _{a min}	EG35	TI25
R/L105.8V10.1.8	1,0	0,50	2	7	10	25	2	8	▲/▲	▲/▲
R/L105.8V16.1.8	1,6	0,80	2	7	10	25	3	8	▲/▲	▲/▲
R/L105.8V20.1.8	2,0	1,00	2	7	10	25	4	8	▲/▲	▲/▲
R/L105.8V25.1.8	2,5	1,25	2	7	10	25	5	8	▲/Δ	▲/▲
R/L105.8V30.1.8	3,0	1,50	2	7	10	25	6	8	▲/▲	▲/▲
R/L105.8V10.2.8	1,0	0,50	2	7	15	35	2	8	▲/▲	▲/▲
R/L105.8V16.2.8	1,6	0,80	2	7	15	35	3	8	▲/Δ	▲/▲
R/L105.8V20.2.8	2,0	1,00	2	7	15	35	4	8	▲/▲	▲/▲
R/L105.8V25.2.8	2,5	1,25	2	7	15	35	5	8	▲/Δ	▲/Δ
R/L105.8V30.2.8	3,0	1,50	2	7	15	35	6	8	▲/Δ	▲/▲

▲ ab Lager / on stock Δ 4 Wochen / 4 weeks x auf Anfrage / upon request

● empfohlen / recommended

o bedingt einsetzbar / alternative recommendation

- nicht geeignet / not suitable

■ unbeschichtete HM-Sorten / uncoated grades

■ beschichtete HM-Sorten / coated grades

■ bestückt/Cermet / brazed/Cermet

Abmessungen in mm

Dimensions in mm

Ausführung R oder L angeben

State R or L version

P	•	•
M	•	•
K	o	•
N	-	•
S	-	•
H	-	-

HM-Sorten
Carbide grades



Axialeinstechen

Face Grooving



Klemmhalter

Toolholder

B105

mit innerer Kühlmittelzufuhr
with through coolant supply

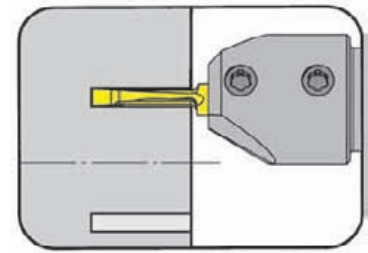

Nutaußen-Ø ab	from outer groove Ø	10,0 mm
Stechtiefe	Depth of groove	15,0 mm
Stechbreite	Width of groove	2,0 - 3,0 mm

Verlängerte Aufnahme der Platte
Extended depth of insert seat

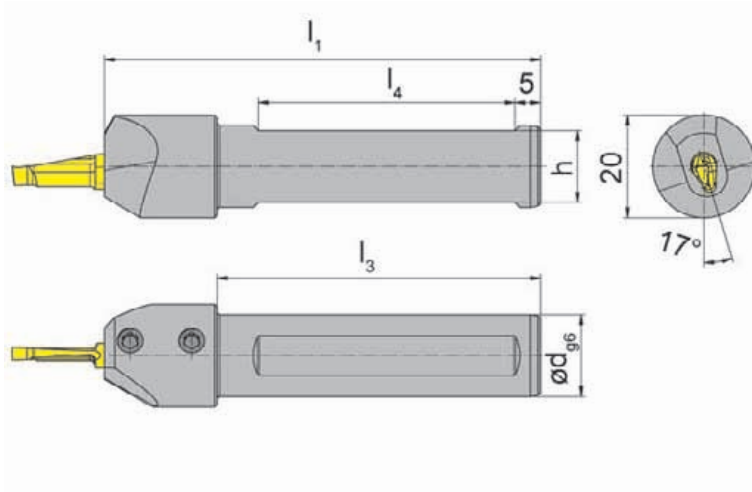

Schneidplatte
Insert

Typ A105...2.2
Type

L = links wie gezeichnet
L = left hand version shown

R = rechts spiegelbildlich
R = right hand version

Bestellnummer Part number	d	l ₁	l ₃	h	l ₄
R/LB105.0016.12.2	16	85	63	14	50
R/LB105.0020.12.2	20	100	-	18	55

Ausführung R oder L angeben
State R or L version

Abmessungen in mm
Dimensions in mm

Weitere Abmessungen auf Anfrage
Further sizes upon request

Das Anzugsdrehmoment der Schrauben finden Sie in den Technischen Hinweisen.
For torque specification of the screw, please see Technical Instructions.

Ersatzteile

Spare Parts

Klemmhalter Toolholder	Spannschraube Screw	TORX PLUS®-Schlüssel TORX PLUS® Wrench
R/LB105...	6.075T15P	T15PQ

Axialeinstechen

Face Grooving



Schneidplatte

Insert

A105

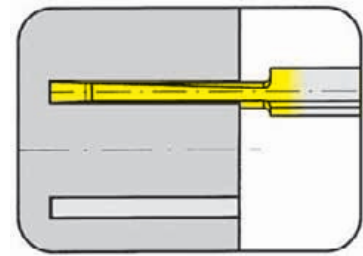

Nutaußen-Ø ab	from outer groove Ø	10 mm
Stechtiefe	Depth of groove	15 mm
Stechbreite	Width of groove	2-3 mm

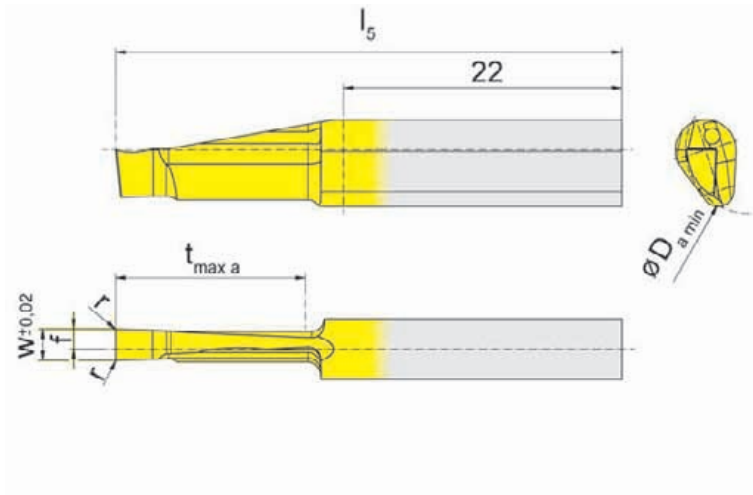

Klemmhalter
Toolholder

Typ B105...12.2
Type

L = links wie gezeichnet
L = left hand version shown

R = rechts spiegelbildlich
R = right hand version

Bestellnummer Part number	w	r	f	l ₅	t _{max a}	D _{a min}	EG35	T125
R/LA105.1020.2.2	2,0	0,1	1,4	40	15	10	▲/▲	▲/▲
R/LA105.1025.2.2	2,5	0,1	1,6	40	15	10	▲/▲	▲/▲
R/LA105.1030.2.2	3,0	0,1	1,0	40	15	10	▲/▲	▲/▲
							P	•
							M	•
							K	•
							N	-
							S	-
							H	-

▲ ab Lager / on stock Δ 4 Wochen / 4 weeks x auf Anfrage / upon request

● empfohlen / recommended

o bedingt einsetzbar / alternative recommendation

- nicht geeignet / not suitable

■ unbeschichtete HM-Sorten / uncoated grades

■ beschichtete HM-Sorten / coated grades

■ bestückt/Cermet / brazed/Cermet

Abmessungen in mm

Dimensions in mm

Ausführung R oder L angeben

State R or L version

Hinweis:

Schneidplatte RA105 in Klemmhalter RB105...12.2 und Schneidplatte LA105 in Klemmhalter LB105...12.2 verwenden.

Note:

Use insert RA105 in toolholder RB105...12.2 and insert LA105 in toolholder LB105...12.2.

Axialstechen ins Volle bei voller Stechtiefe nur bei D_{amin} 10 - 40 mm möglich!

Face grooving with full width of the full depth only possible between D_{amin} 10 - 40 mm!

HM-Sorten
Carbide grades



Axialeinstechen

Face Grooving

Klemmhalter
Toolholder
B110

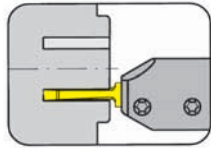

Seite/Page
S18

Schneidplatte
Insert
A110

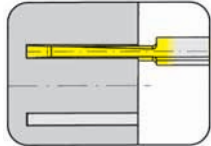

Seite/Page
S19

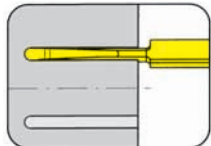

Seite/Page
S20

S

110



S

**Klemmhalter mit
Schneidplatten**

Stechbreite 3,0 mm

**Toolholder with
Inserts**

Width of groove 3,0 mm

Axialeinstechen

Face Grooving



Klemmhalter

Toolholder

B110

mit innerer Kühlmittelzufuhr
with through coolant supply

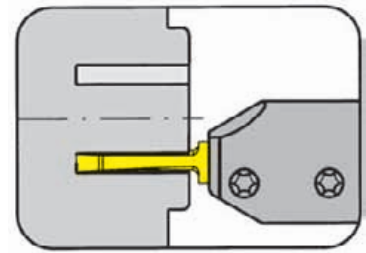

Nutaußen-Ø ab	from outer groove Ø	20,0 mm
Stechtiefe	Depth of groove	30,0 mm
Stechbreite bis	Width of groove up to	3,0 mm

Verlängerte Aufnahme der Platte
Extended depth of insert seat

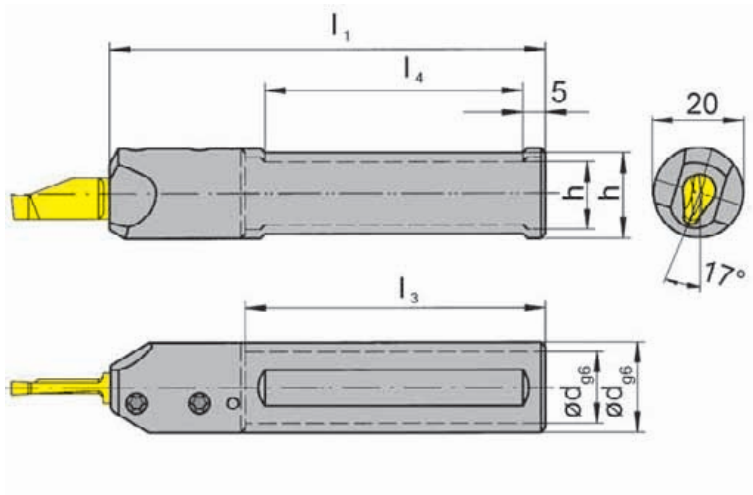

Schneidplatte
Insert

Typ A110
Type

R = rechts wie gezeichnet
R = right hand version shown

L = links spiegelbildlich
L = left hand version

Bestellnummer Part number	d	l ₁	l ₃	h	l ₄
R/LB110.0016.16.2	16	100	70	14	55
R/LB110.0020.16.2	20	100	-	18	55

Ausführung R oder L angeben
State R or L version

Abmessungen in mm
Dimensions in mm

Weitere Abmessungen auf Anfrage
Further sizes upon request

Das Anzugsdrehmoment der Schrauben finden Sie in den Technischen Hinweisen.
For torque specification of the screw, please see Technical Instructions.

Ersatzteile

Spare Parts

Klemmhalter Toolholder	Spannschraube Screw	TORX PLUS®-Schlüssel TORX PLUS® Wrench
R/LB110...	6.075T15P	T15PQ

Axialeinstechen

Face Grooving



Schneidplatte

Insert

A110

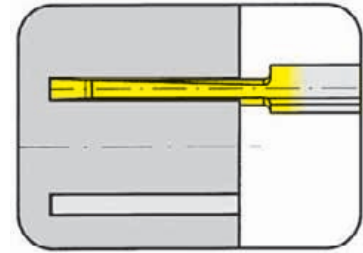

Nutaußen-Ø ab	from outer groove Ø	20 mm
Stechtiefe	Depth of groove	20-30 mm
Stechbreite	Width of groove	3 mm

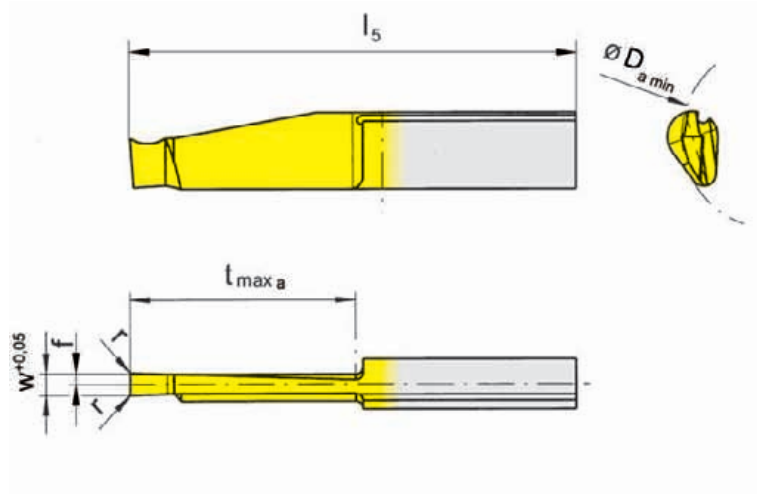

Klemmhalter
Toolholder

Typ B110
Type

L = links wie gezeichnet
L = left hand version shown

R = rechts spiegelbildlich
R = right hand version

Bestellnummer Part number	w	r	f	l ₅	t _{max a}	D _{a min}	EG35	TH35	TI25	TN35	
R/LA110.2030.3.0	3	0,2	1,5	50	20	20	▲▲	▲▲	▲▲	▲▲	
R/LA110.2030.5.0	3	0,2	1,5	60	30	20	▲▲	▲▲	▲▲	▲▲	
R/LA110.5030.3.0	3	0,2	1,5	50	20	50	▲▲		▲▲		
R/LA110.5030.5.0	3	0,2	1,5	60	30	50	▲▲		▲▲		
▲ ab Lager / on stock Δ 4 Wochen / 4 weeks x auf Anfrage / upon request							P	•	•	•	•
● empfohlen / recommended							M	•	•	•	•
o bedingt einsetzbar / alternative recommendation							K	o	•	•	•
- nicht geeignet / not suitable							N	-	•	•	•
■ unbeschichtete HM-Sorten / uncoated grades							S	-	•	•	•
■ beschichtete HM-Sorten / coated grades							H	-	-	-	-
■ bestückt/Cermet / brazed/Cermet											

Abmessungen in mm
Dimensions in mm

Ausführung R oder L angeben
State R or L version

Hinweis:

Schneidplatte RA110 in Klemmhalter RB110...16.2 und Schneidplatte LA110 in Klemmhalter LB110...16.2 verwenden.

Note:

Use insert RA110 in toolholder RB110...16.2 and insert LA110 in toolholder LB110...16.2.

Axialstechen ins Volle bei voller Stechtiefe nur bei D_{amin} 20 - 50 mm möglich!

Face grooving with full width of the full depth only possible between D_{amin} 20 - 50 mm.

HM-Sorten
Carbide grades



Axialeinstechen

Face Grooving



Schneidplatte

Insert

A110

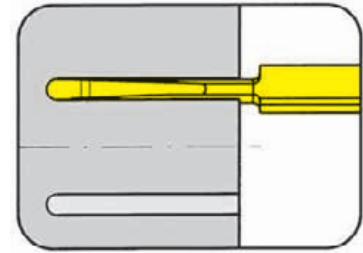

Nutaußen-Ø ab	from outer groove Ø	20 mm
Stechtiefe	Depth of groove	30 mm
Stechbreite	Width of groove	3 mm

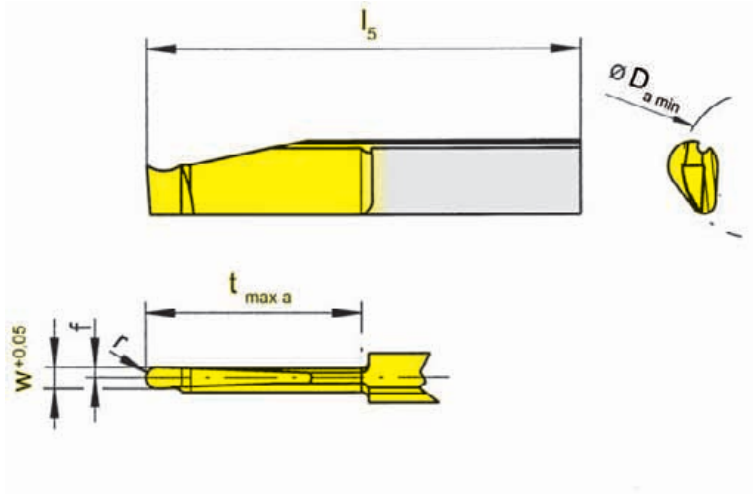

Klemmhalter
Toolholder

Typ B110
Type

S

Vollradius
Full radius

L = links wie gezeichnet
L = left hand version shown

R = rechts spiegelbildlich
R = right hand version

Bestellnummer Part number	w	r	f	l ₅	t _{max a}	D _{a min}	EG35	TN35
R/LA110.2030.15.5.0	3	1,5	1,5	60	30	20	▲/▲	▲/▲

- ▲ ab Lager / on stock Δ 4 Wochen / 4 weeks x auf Anfrage / upon request
- empfohlen / recommended
- o bedingt einsetzbar / alternative recommendation
- nicht geeignet / not suitable
- unbeschichtete HM-Sorten / uncoated grades
- beschichtete HM-Sorten / coated grades
- bestückt/Cermet / brazed/Cermet

P	●	●
M	●	●
K	○	●
N	-	●
S	-	●
H	-	-

Abmessungen in mm
Dimensions in mm

Ausführung R oder L angeben
State R or L version

Hinweis:

Schneidplatte RA110 in Klemmhalter RB110...16.2 und Schneidplatte LA110 in Klemmhalter LB110...16.2 verwenden.

Note:

Use insert RA110 in toolholder RB110...16.2 and insert LA110 in toolholder LB110...16.2.
Axialstechen ins Volle bei voller Stechtiefe nur bei D_{amin} 20 - 50 mm möglich!
Face grooving with full width of the full depth only possible between D_{amin} 20 - 50 mm.

HM-Sorten
Carbide grades



Klemmhalter
Toolholder
B114/BA114

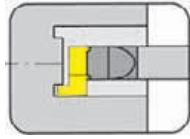

Seite/Page
S24-S27

Klemmhalter
Toolholder
HC114



Seite/Page
S28

Schneidplatte
Insert
114

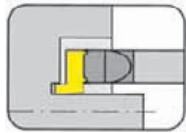

Seite/Page
S29-S32

S

114



S

**Klemmhalter mit
Schneidplatten**

Stechbreite 1,0 - 3,0 mm

**Toolholder with
Inserts**

Width of groove 1,0 - 3,0 mm

Axialeinstechen

Face Grooving



Klemmhalter

Toolholder

B114

mit innerer Kühlmittelzufuhr
with through coolant supply

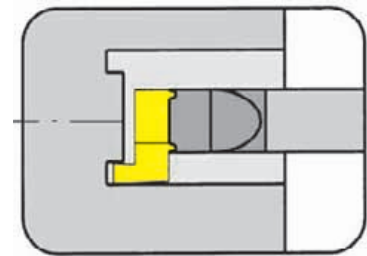

Einfahrtiefe bis	Depth of bore up to	64,0 mm
Stechtiefe bis	Depth of groove up to	6,0 mm
Stechbreite	Width of groove	1,0 - 3,0 mm

Schaftmaterial: Hartmetall (schwingungsarm)
Material of shank: Carbide - Giving a good vibration resistance

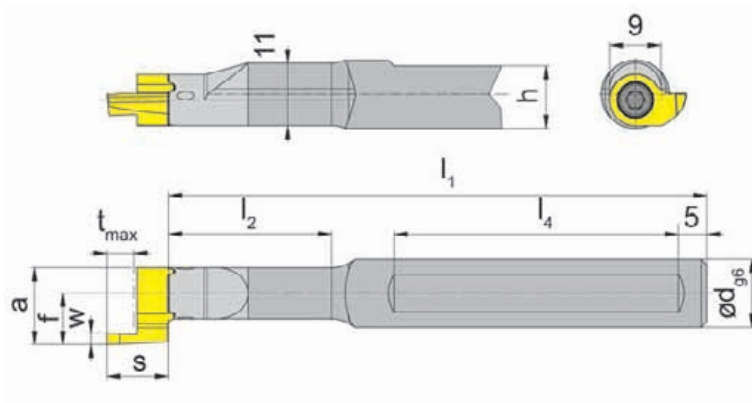

Schneidplatte
Insert

Typ 114
Type S114

Abbildung = rechtsschneidend
Picture = right hand cutting version

Bestellnummer Part number	d	l ₁	l ₂	h	l ₄
B114.0012.00	12	69,7	14,2	11	40
B114.0012.01	12	94,7	28,7	11	50
B114.0012.02	12	104,7	39,7	11	50
B114.0012.03	12	124,7	58,7	11	50
B114.0016.00	16	74,7	14,2	15	40
B114.0016.01	16	94,7	28,7	15	50
B114.0016.02	16	104,7	39,7	15	50
B114.0016.03	16	124,7	58,7	15	50

Weitere Abmessungen auf Anfrage
Further sizes upon request

w, a, s, t_{max} und f siehe Schneidplatten
w, a, s, t_{max} and f see inserts

Abmessungen in mm
Dimensions in mm

Bestellhinweis:

Klemmhalter sind jeweils für rechte und linke Schneidplatten verwendbar.

Klemmhalter mit beschädigter Schneidplattenaufnahme können durch unseren Reparaturservice instand gesetzt werden.

Ordering note:

Toolholders can be used with right and left hand inserts. Toolholders with damaged seating can be repaired by HORN.

Das Anzugsdrehmoment der Schrauben finden Sie in den Technischen Hinweisen.
For torque specification of the screw, please see Technical Instructions.

Ersatzteile

Spare Parts

Klemmhalter Toolholder	Spannschraube Screw	TORX PLUS®-Schlüssel TORX PLUS® Wrench
B114...	4.12T15EP	T15PQ

Axialeinstechen

Face Grooving



Klemmhalter

Toolholder

B114

mit innerer Kühlmittelzufuhr
with through coolant supply

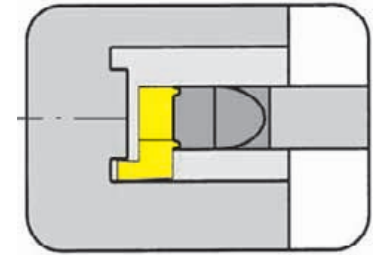

Einfahrtiefe bis	Depth of bore up to	64,0 mm
Stechtiefe bis	Depth of groove up to	6,0 mm
Stechbreite	Width of groove	1,0 - 3,0 mm

Schaftmaterial: Hartmetall (schwingungsarm)
Material of shank: Carbide - Giving a good vibration resistance

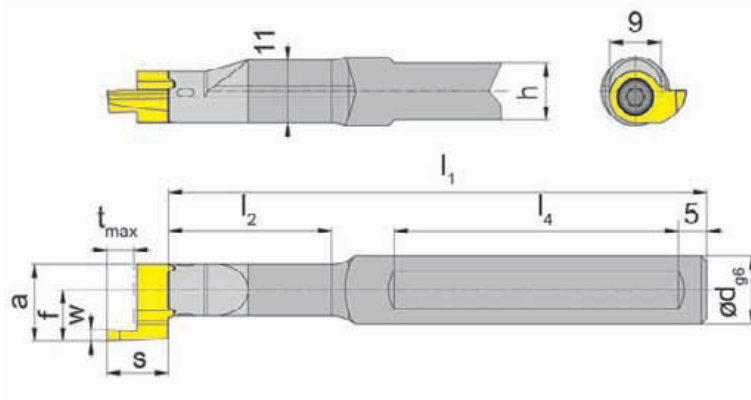

Schneidplatte
Insert

Typ 114
Type S114

Abbildung = rechtsschneidend
Picture = right hand cutting version

mit 2 Spannflächen
with 2 clamping flats

Bestellnummer Part number	d	l ₁	l ₂	h	l ₄
B114.0012.2.00	12	69,7	14,2	11	40
B114.0012.2.01	12	94,7	28,7	11	50
B114.0012.2.02	12	104,7	39,7	11	50
B114.0012.2.03	12	124,7	58,7	11	50
B114.0016.2.00	16	74,7	14,2	14	40
B114.0016.2.01	16	94,7	28,7	14	50
B114.0016.2.02	16	104,7	39,7	14	50
B114.0016.2.03	16	124,7	58,7	14	50

Weitere Abmessungen auf Anfrage
Further sizes upon request

w, a, s, t_{max} und f siehe Schneidplatten
w, a, s, t_{max} and f see inserts

Abmessungen in mm
Dimensions in mm

Bestellhinweis:

Klemmhalter sind jeweils für rechte und linke Schneidplatten verwendbar.
Klemmhalter mit beschädigter Schneidplattenaufnahme können durch unseren Reparaturservice instand gesetzt werden.

Ordering note:

Toolholders can be used with right and left hand inserts. Toolholders with damaged seating can be repaired by HORN.

Das Anzugsdrehmoment der Schrauben finden Sie in den Technischen Hinweisen.
For torque specification of the screw, please see Technical Instructions.

Ersatzteile

Spare Parts

Klemmhalter Toolholder	Spannschraube Screw	TORX PLUS®-Schlüssel TORX PLUS® Wrench
B114...	4.12T15EP	T15PQ

Axialeinstechen

Face Grooving



Klemmhalter

Toolholder

RBA114

mit innerer Kühlmittelzufuhr
with through coolant supply

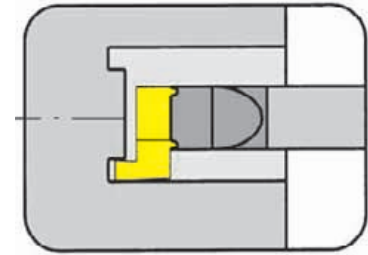

Bohrungs-Ø	Bore Ø	14,0 mm
Stechtiefe	Depth of groove	6,0 mm
Stechbreite bis	Width of groove up to	3,0 mm

Schaftmaterial: Hartmetall (schwingungsarm)
Material of shank: Carbide - Giving a good vibration resistance

Schneidplatte
Insert

Typ R114 (axial)
Type



Abbildung = rechtsschneidend
Picture = right hand cutting version

Bestellnummer Part number	d	l ₁	l ₂	h	l ₄
RBA114.0016.01	16	99,7	28,7	15	50
RBA114.0016.02	16	109,7	39,7	15	50

Weitere Abmessungen auf Anfrage
Further sizes upon request

w, a, s, t_{max} und f siehe Schneidplatten
w, a, s, t_{max} and f see inserts

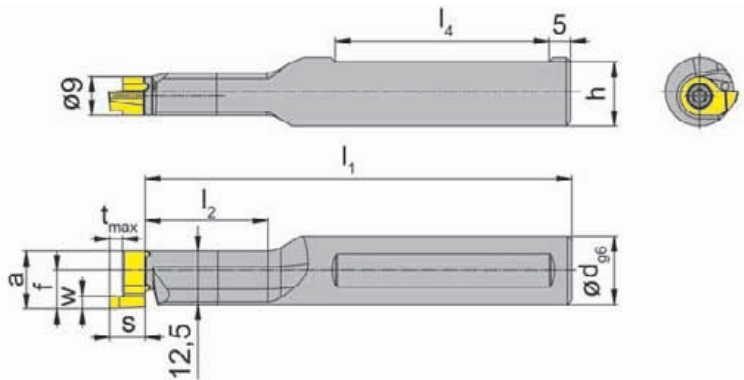
Abmessungen in mm
Dimensions in mm

Bestellhinweis:

Klemmhalter mit beschädigter Schneidplattenaufnahme können durch unseren Reparaturservice instand gesetzt werden.

Ordering note:

Toolholders with damaged seating can be repaired by HORN.

Das Anzugsdrehmoment der Schrauben finden Sie in den Technischen Hinweisen.

For torque specification of the screw, please see Technical Instructions.

Ersatzteile

Spare Parts

Klemmhalter Toolholder	Spannschraube Screw	TORX PLUS®-Schlüssel TORX PLUS® Wrench
RBA114...	4.12T15EP	T15PQ

Axialeinstechen

Face Grooving



Klemmhalter

Toolholder

B114

mit innerer Kühlmittelzufuhr
with through coolant supply

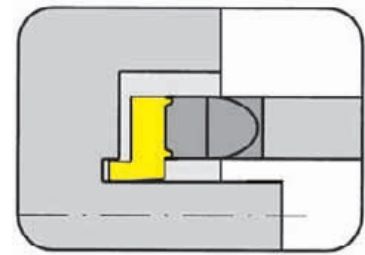

Bohrungs-Ø ab	Bore Ø from	14,0 mm
Stechtiefe bis	Depth of groove up to	6,0 mm
Stechbreite	Width of groove	1,0 - 3,0 mm

Schaftmaterial: Hartmetall (schwingungsarm)
Material of shank: Carbide - Giving a good vibration resistance

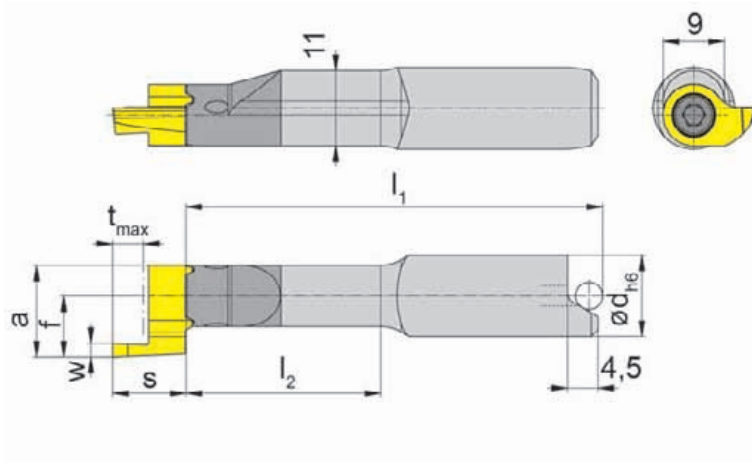

Schneidplatte
Insert

Typ 114
Type S114

Abbildung = rechtsschneidend
Picture = right hand cutting version

zum lageorientierten
Schrumpfen
for shrinkage location



Bestellnummer Part number	d	l ₁	l ₂
B114.0012.00S	12	47,4	14,2
B114.0012.01S	12	61,4	28,7
B114.0012.02S	12	72,4	39,7
B114.0012.03S	12	91,4	58,7

Weitere Abmessungen auf Anfrage
Further sizes upon request

w, a, s, t_{max} und f siehe Schneidplatten
w, a, s, t_{max} and f see inserts

Abmessungen in mm
Dimensions in mm

Bestellhinweis:

Klemmhalter sind jeweils für rechte und linke Schneidplatten verwendbar.
Klemmhalter mit beschädigter Schneidplattenaufnahme können durch unseren Reparaturservice instand gesetzt werden.

Ordering note:

Toolholders can be used with right and left hand inserts. Toolholders with damaged seating can be repaired by HORN.

Das Anzugsdrehmoment der Schrauben finden Sie in den Technischen Hinweisen.
For torque specification of the screw, please see Technical Instructions.

Ersatzteile

Spare Parts

Klemmhalter Toolholder	Spannschraube Screw	TORX PLUS®-Schlüssel TORX PLUS® Wrench
B114...	4.12T15EP	T15PQ

Einstechen und Axialeinstechen

Grooving and Face Grooving



Klemmhalter

Toolholder

HC114

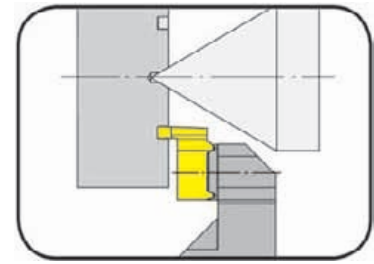

Stechtiefe bis	Depth of groove up to	6,0 mm
Stechbreite bis	Width of groove up to	3,0 mm

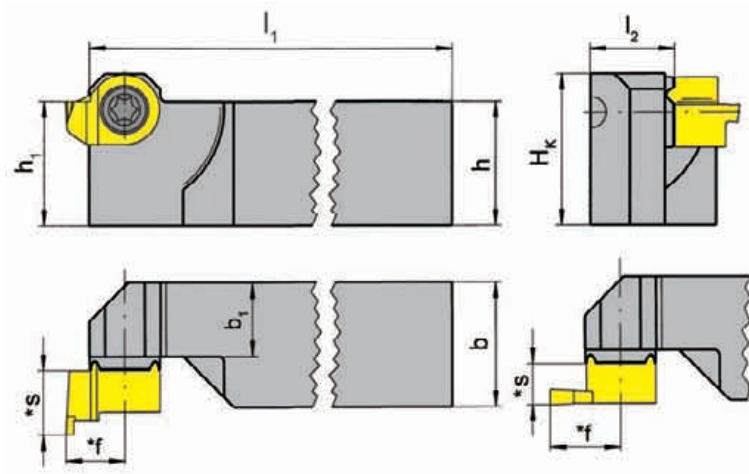

Schneidplatte
Insert

Typ 114
Type S114
U114

axial und radial
axial and radial

R = rechts wie gezeichnet
R = right hand version shown

L = links spiegelbildlich
L = left hand version

Bestellnummer Part number	h	b	l ₂	h ₁	b ₁	H _k	l ₁
R/LHC114.1212.01	12	12	11,2	12	9,5	15,6	122
R/LHC114.1616.01	16	16	11,2	16	9,5	19,6	122
R/LHC114.2020.01	20	20	15,2	20	13,5	23,6	122
R/LHC114.2525.01	25	25	20,2	25	18,5	28,6	147

Weitere Abmessungen auf Anfrage
Further sizes upon request

* siehe Schneidplatten
* see inserts

Abmessungen in mm
Dimensions in mm

Ausführung R oder L angeben
State R or L version

Bestellhinweis:

Rechte Klemmhalter verwendbar für linke Schneidplatten. Linke Klemmhalter verwendbar für rechte Schneidplatten.

Ordering note:

Right hand toolholders use left hand inserts. Left hand toolholders use right hand inserts.

Das Anzugsdrehmoment der Schrauben finden Sie in den Technischen Hinweisen.

For torque specification of the screw, please see Technical Instructions.

Ersatzteile

Spare Parts

Klemmhalter Toolholder	Spannschraube Screw	TORX PLUS®-Schlüssel TORX PLUS® Wrench
R/LHC114...	4.12T15EP	T15PQ

Axialeinstechen

Face Grooving



Schneidplatte

Insert

114

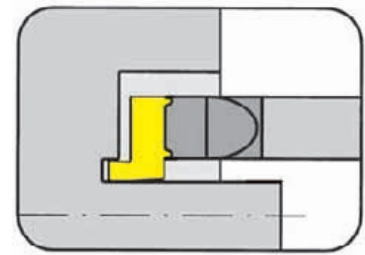

Nutaußen-Ø ab	from outer groove Ø	12 mm
Stechtiefe bis	Depth of groove up to	6 mm
Stechbreite	Width of groove	1-3 mm

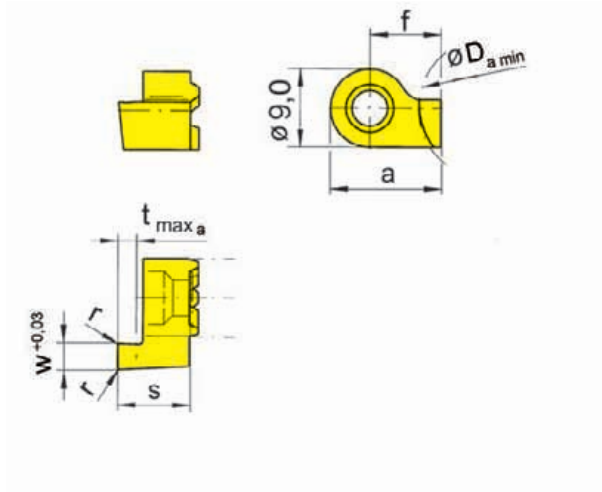

Klemmhalter
Toolholder

Typ B114
Type RBA114
HC114

R = rechts wie gezeichnet
R = right hand version shown

L = links spiegelbildlich
L = left hand version

Bearbeitung **HINTER** der
Drehmitte!
Machining **BEHIND** centre
line

Bestellnummer Part number	w	s	f	a	r	t _{max a}	D _{a min}	EG55	TN35
R/L114.1210.00	1,0	8,3	7,5	12	-	1,5	12	▲/▲	▲/▲
R/L114.1215.00	1,5	8,3	7,5	12	0,2	2,5	12	▲/▲	▲/▲
R/L114.1220.00	2,0	8,3	7,5	12	0,2	3,0	12	▲/▲	▲/▲
R/L114.1225.00	2,5	8,3	7,5	12	0,2	3,0	12	▲/▲	▲/▲
R/L114.1230.00	3,0	8,3	7,5	12	0,2	3,0	12	▲/▲	▲/▲
R/L114.1220.5.00	2,0	10,8	7,5	12	0,2	5,0	12	▲/▲	▲/▲
R/L114.1225.5.00	2,5	10,8	7,5	12	0,2	5,0	12	▲/▲	▲/▲
R/L114.1230.6.00	3,0	11,8	7,5	12	0,2	6,0	12	▲/▲	▲/▲

▲ ab Lager / on stock Δ 4 Wochen / 4 weeks x auf Anfrage / upon request

● empfohlen / recommended

o bedingt einsetzbar / alternative recommendation

- nicht geeignet / not suitable

■ unbeschichtete HM-Sorten / uncoated grades

■ beschichtete HM-Sorten / coated grades

■ bestückt/Cermet / brazed/Cermet

Abmessungen in mm

Dimensions in mm

Ausführung R oder L angeben

State R or L version

Hinweis:

Ausführung R = Spindel linksdrehend! Bei Verwendung der Axialstechplatte Typ 114 mit Klemmhalter Typ B114 verlängern sich die Haltermaße I₁ und I₂ um 3,0 / 5,5 oder 6,5 mm.

Note:

R = rotation anti-clockwise! Using the face grooving insert type 114 on toolholder type B114 the size I₁ and I₂ will be enlarged by 3,0 / 5,5 or 6,5 mm.

P	●	●
M	○	●
K	○	●
N	-	●
S	-	●
H	-	-

HM-Sorten
Carbide grades



Axialeinstechen

Face Grooving



Schneidplatte

Insert

114

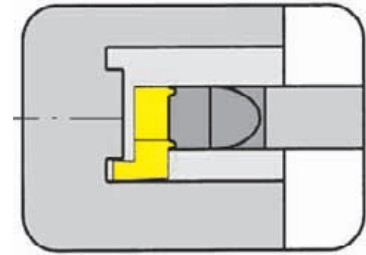

Nutaußen-Ø ab	from outer groove Ø	14 mm
Stechtiefe bis	Depth of groove up to	6 mm
Stechbreite	Width of groove	1-3 mm

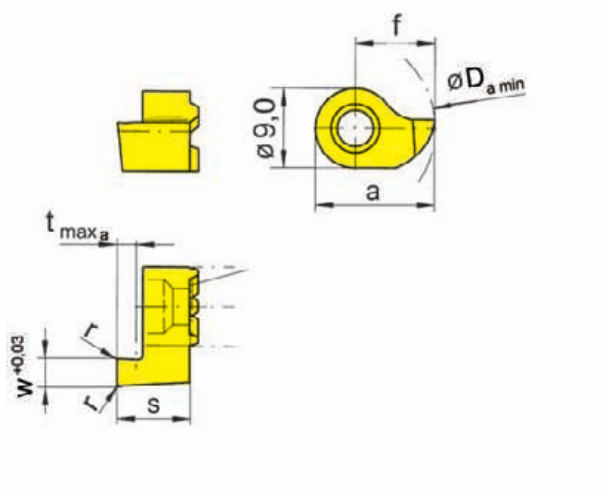

Klemhalter
Toolholder

Typ B114
Type RBA114
HC114

S

R = rechts wie gezeichnet
R = right hand version shown

L = links spiegelbildlich
L = left hand version

Bearbeitung **VOR** der
Drehmitte!
Machining **IN-FRONT** of
centre line

Bestellnummer Part number	w	s	f	a	r	t _{max a}	D _{a min}	MG12	EG55	TF45	TN35
R/L114.1410.00	1,0	8,3	9	13,5	-	1,5	14	Δ/Δ	▲/▲		▲/▲
R/L114.1415.00	1,5	8,3	9	13,5	0,2	2,5	14		▲/▲		▲/▲
R/L114.1420.00	2,0	8,3	9	13,5	0,2	3,0	14		▲/▲	x/x	▲/▲
R/L114.1425.00	2,5	8,3	9	13,5	0,2	3,0	14		▲/▲		▲/▲
R/L114.1430.00	3,0	8,3	9	13,5	0,2	3,0	14	▲/Δ	▲/▲		▲/▲
R/L114.1420.5.00	2,0	10,8	9	13,5	0,2	5,0	14		▲/▲		▲/▲
R/L114.1425.5.00	2,5	10,8	9	13,5	0,2	5,0	14		▲/▲		▲/▲
R/L114.1430.6.00	3,0	11,8	9	13,5	0,2	6,0	14		▲/▲		▲/▲

▲ ab Lager / on stock Δ 4 Wochen / 4 weeks x auf Anfrage / upon request

● empfohlen / recommended

o bedingt einsetzbar / alternative recommendation

- nicht geeignet / not suitable

■ unbeschichtete HM-Sorten / uncoated grades

■ beschichtete HM-Sorten / coated grades

■ bestückt/Cermet / brazed/Cermet

Abmessungen in mm

Dimensions in mm

Ausführung R oder L angeben

State R or L version

Hinweis:

Ausführung R = Spindel rechtsdrehend! Bei Verwendung der Axialstechplatte Typ 114 mit Klemhalter Typ B114 verlängern sich die Haltermaße l_1 und l_2 um 3,0 / 5,5 oder 6,5 mm.

Note:

R = rotation clockwise! Using the face grooving insert type 114 on toolholder type B114 the size l_1 and l_2 will be enlarged by 3,0 / 5,5 or 6,5 mm.

P	○	●	●	●
M	●	○	●	●
K	●	○	●	●
N	●	-	●	●
S	●	-	●	●
H	-	-	-	-

HM-Sorten
Carbide grades

Axialeinstechen

Face Grooving



Schneidplatte

Insert

114

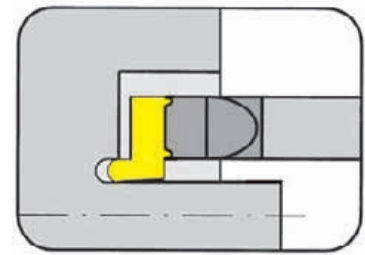

Nutaußen-Ø ab	from outer groove Ø	12 mm
Stechtiefe bis	Depth of groove up to	6 mm
Stechbreite	Width of groove	2-3 mm

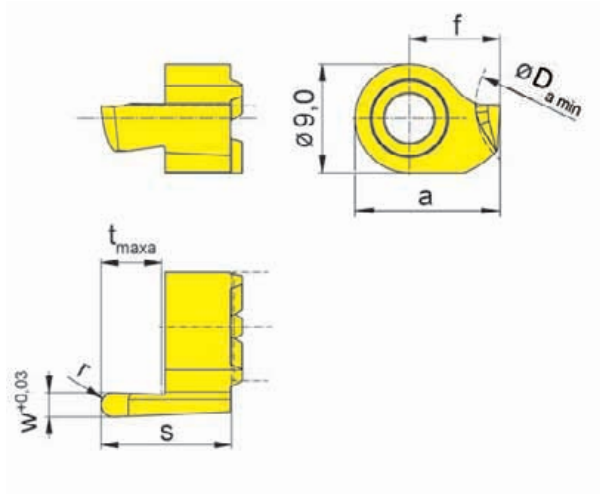

R = rechts wie gezeichnet
R = right hand version shown

L = links spiegelbildlich
L = left hand version

Klemmhalter
Toolholder

Typ B114
Type RBA114
HC114

Vollradius Bearbeitung
HINTER der Drehmitte!
Full radius Machining
BEHIND centre line

Bestellnummer Part number	w	s	f	a	r	t _{max a}	D _{a min}	EG55	TN35
R/L114.1220.5.10	2,0	10,8	7,5	12	1,00	5	12	▲/▲	▲/▲
R/L114.1225.5.12	2,5	10,8	7,5	12	1,25	5	12	▲/▲	▲/▲
R/L114.1230.6.15	3,0	11,8	7,5	12	1,50	6	12	▲/▲	▲/▲

▲ ab Lager / on stock Δ 4 Wochen / 4 weeks x auf Anfrage / upon request

● empfohlen / recommended

o bedingt einsetzbar / alternative recommendation

- nicht geeignet / not suitable

■ unbeschichtete HM-Sorten / uncoated grades

■ beschichtete HM-Sorten / coated grades

■ bestückt/Cermet / brazed/Cermet

Abmessungen in mm

Dimensions in mm

Ausführung R oder L angeben

State R or L version

Hinweis:

Ausführung R = Spindel linksdrehend! Bei Verwendung der Axialstechplatte Typ 114 mit Klemmhalter Typ B114 verlängern sich die Haltermaße l_1 und l_2 um 5,5 oder 6,5 mm.

Note:

R = rotation anti-clockwise! Using the face grooving insert type 114 on toolholder type B114 the size l_1 and l_2 will be enlarged by 5,5 mm or 6,5 mm.

P	•	•
M	o	•
K	o	•
N	-	•
S	-	•
H	-	-

HM-Sorten
Carbide grades

Axialeinstechen

Face Grooving



Schneidplatte

Insert

114

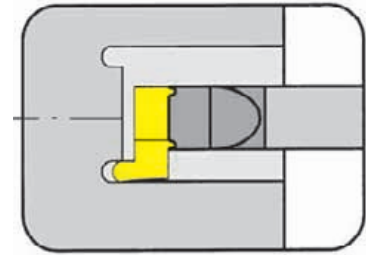

Nutaußen-Ø ab	from outer groove Ø	14 mm
Stechtiefe bis	Depth of groove up to	3 mm
Stechbreite	Width of groove	1-3 mm

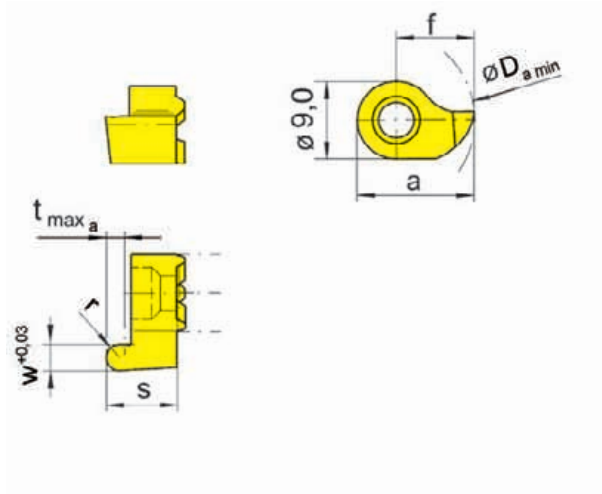

Klemhalter
Toolholder

Typ B114
Type RBA114
HC114

R = rechts wie gezeichnet
R = right hand version shown

L = links spiegelbildlich
L = left hand version

Vollradius Bearbeitung
VOR der Drehmitte!
Full radius Machining
IN-FRONT of centre line

Bestellnummer Part number	w	s	f	a	r	t _{max a}	D _{min}	EG55	TN35
R/L114.1410.05	1,0	8,3	9	13,5	0,50	1,5	14	▲/▲	▲/▲
R/L114.1416.08	1,6	8,3	9	13,5	0,80	2,5	14	▲/▲	▲/▲
R/L114.1420.10	2,0	8,3	9	13,5	1,00	3,0	14	▲/▲	▲/▲
R/L114.1425.12	2,5	8,3	9	13,5	1,25	3,0	14	▲/▲	▲/▲
R/L114.1430.15	3,0	8,3	9	13,5	1,50	3,0	14	▲/▲	▲/▲

▲ ab Lager / on stock Δ 4 Wochen / 4 weeks x auf Anfrage / upon request

● empfohlen / recommended

o bedingt einsetzbar / alternative recommendation

- nicht geeignet / not suitable

■ unbeschichtete HM-Sorten / uncoated grades

■ beschichtete HM-Sorten / coated grades

■ bestückt/Cermet / brazed/Cermet

Abmessungen in mm

Dimensions in mm

Ausführung R oder L angeben

State R or L version

Hinweis:

Ausführung R = Spindel rechtsdrehend! Bei Verwendung der Axialstechplatte Typ 114 mit Klemhalter Typ B114 verlängern sich die Haltermaße I₁ und I₂ um 3,0 mm.

Note:

R = rotation clockwise! Using the face grooving insert type 114 on toolholder type B114 the size I₁ and I₂ will be enlarged by 3,0 mm.

P	●	●
M	○	●
K	○	●
N	-	●
S	-	●
H	-	-

HM-Sorten
Carbide grades



Klemmhalter
Toolholder
H25A/IB25A

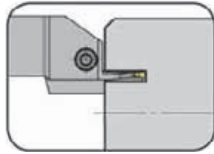

Seite/Page
S36

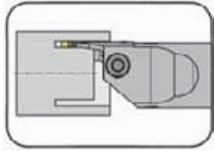

Seite/Page
S38

Kassette
Cassette
K25A

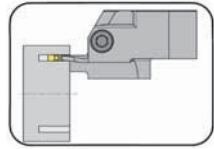

Seite/Page
S37

Schneidplatte
Insert
S15A



Seite/Page
S39-S40

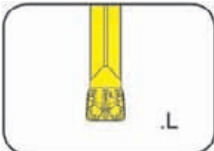

Seite/Page
S41

Wendeschneidplatte
Indexable insert
S25A



Seite/Page
S42-S43

S15A / S25A



S

**Klemmhalter mit
Schneidplatten**

Stechbreite 2 - 4 mm

**Toolholder with
Inserts**

Width of groove 2 - 4 mm

Axialeinstechen

Face Grooving



Klemmhalter

Toolholder

H25A

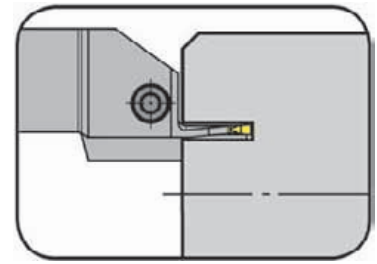

Nutaußen-Ø ab	from outer groove Ø	15 mm
Stechtiefe bis	Depth of groove up to	15 mm
Stechbreite	Width of groove	2,0 - 3,0 mm

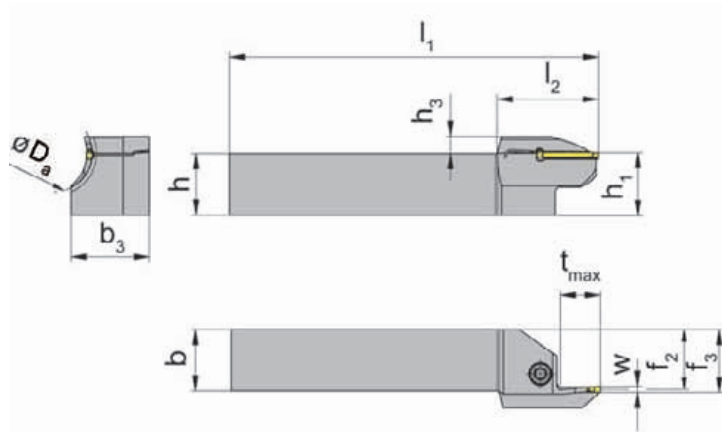

Wendeschneidplatte
Indexable insert

Typ S15A
Type S25A

Spitzenhöhe liegt 0,3 mm
über Drehmitte
The cutting edge must be set
0.3 mm above centre height

L = links wie gezeichnet
L = left hand version shown

R = rechts spiegelbildlich
R = right hand version

Bestellnummer Part number	h	b	l ₁	l ₂	h ₁	b ₃	f ₂	f ₃	t _{max}	h ₃	D _{a min}	D _{a max}	Größe Size
R/LAH25A.12.1520.02	12	12	120	32	12,3	15,5	11,5	12,5	12	5,0	15	20	02
R/LAH25A.16.1520.02	16	16	120	32	16,3	19,5	15,5	16,5	12	5,0	15	20	02
R/LAH25A.20.1520.02	20	20	120	32	20,3	23,5	19,5	20,5	12	5,0	15	20	02
R/LAH25A.12.2025.02	12	12	120	32	12,3	16,5	11,5	12,5	12	5,0	20	25	02
R/LAH25A.16.2025.02	16	16	120	32	16,3	20,5	15,5	16,5	12	5,0	20	25	02
R/LAH25A.20.2025.02	20	20	120	32	20,3	24,5	19,5	20,5	12	5,0	20	25	02
R/LAH25A.12.2530.02	12	12	120	33	12,3	17,5	11,5	12,5	13	5,5	25	30	02
R/LAH25A.16.2530.02	16	16	120	33	16,3	21,5	15,5	16,5	13	5,5	25	30	02
R/LAH25A.20.2530.02	20	20	120	33	20,3	25,5	19,5	20,5	13	5,5	25	30	02
R/LAH25A.12.1520.03	12	12	120	33	12,3	17,0	11,0	12,5	13	5,5	15	20	03
R/LAH25A.16.1520.03	16	16	120	33	16,3	21,0	15,0	16,5	13	5,5	15	20	03
R/LAH25A.20.1520.03	20	20	120	33	20,3	25,0	19,0	20,5	13	5,5	15	20	03
R/LAH25A.12.2025.03	12	12	120	34	12,3	18,5	11,0	12,5	14	5,5	20	25	03
R/LAH25A.16.2025.03	16	16	120	34	16,3	22,5	15,0	16,5	14	5,5	20	25	03
R/LAH25A.20.2025.03	20	20	120	34	20,3	26,5	19,0	20,5	14	5,5	20	25	03
R/LAH25A.12.2530.03	12	12	120	35	12,3	19,5	11,0	12,5	15	6,0	25	30	03
R/LAH25A.16.2530.03	16	16	120	35	16,3	23,5	15,0	16,5	15	6,0	25	30	03
R/LAH25A.20.2530.03	20	20	120	35	20,3	27,5	19,0	20,5	15	6,0	25	30	03

Weitere Abmessungen auf Anfrage
Further sizes upon request

w siehe WSP
w see indexable inserts

Abmessungen in mm
Dimensions in mm

Das Anzugsdrehmoment der Schraube für w = 2,0 mm ist 2,5 Nm
Das Anzugsdrehmoment der Schraube für w = 3,0 mm ist 3,0 Nm
Torque specification of the screw for w = 2,0 mm is 2,5 Nm
Torque specification of the screw for w = 3,0 mm is 3,0 Nm

Ersatzteile

Spare Parts

Klemmhalter Toolholder	Spannschraube Screw	TORX PLUS®-Schlüssel TORX PLUS® Wrench
R/LAH25A.12...	5.14T20P	T20PQ
R/LAH25A...	5.13 T20P	T20PQ

Axialeinstechen

Face Grooving



Kassette

Cassette

K25A

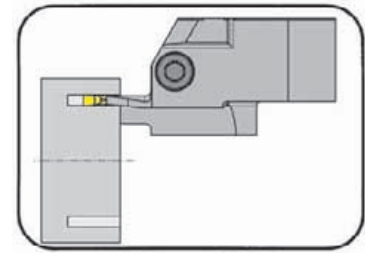

Nutaußen-Ø ab	from outer groove Ø	15 mm
Stechtiefe bis	Depth of groove up to	20 mm
Stechbreite	Width of groove	2,0 - 4,0 mm

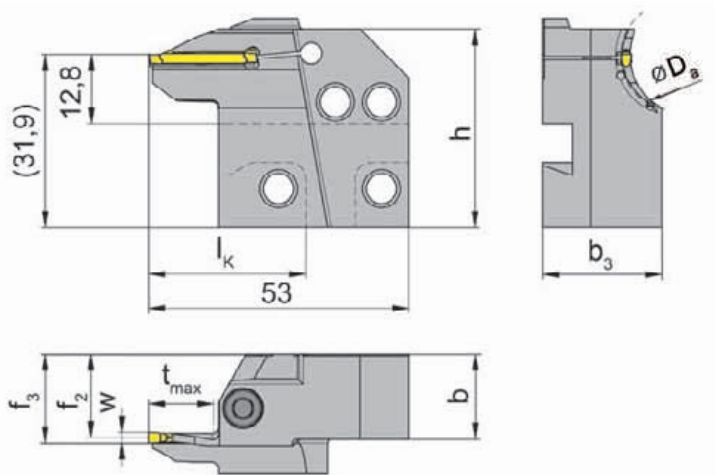

Wendeschneidplatte
Indexable insert

Typ S15A
Type S25A

R = rechts wie gezeichnet
R = right hand version shown

L = links spiegelbildlich
L = left hand version

Spitzenhöhe liegt 0,3 mm
über Drehmitte
The cutting edge must be set
0.3 mm above centre height

Bestellnummer Part number	b	b ₃	t _{max}	f ₃	f ₂	h	D _{a min}	D _{a max}	l _k	Größe Size
R/LAK25A.1520.02.IK	15,7	21	12	f ₂ +w/2	15,4	38,6	15	20	34	02
R/LAK25A.2025.02.IK	15,7	22	12	f ₂ +w/2	15,4	38,6	20	25	34	02
R/LAK25A.2530.02.IK	15,7	23	13	f ₂ +w/2	15,4	38,6	25	30	34	02
R/LAK25A.2025.03.IK	15,7	24	14	f ₂ +w/2	14,9	38,6	20	25	34	03
R/LAK25A.2530.03.IK	15,7	25	15	f ₂ +w/2	14,9	38,6	25	30	34	03
R/LAK25A.3040.03.IK	15,7	23	16	f ₂ +w/2	14,9	38,6	30	40	34	03
R/LAK25A.4050.03.IK	15,7	24	18	f ₂ +w/2	14,9	38,6	40	50	34	03
R/LAK25A.2025.04.IK	15,7	24	16	f ₂ +w/2	15,1	38,6	20	25	34	04
R/LAK25A.2530.04.IK	15,7	24	17	f ₂ +w/2	15,1	38,6	25	30	34	04
R/LAK25A.3040.04.IK	15,7	24	18	f ₂ +w/2	15,1	38,6	30	40	34	04
R/LAK25A.4050.04.IK	15,7	24	20	f ₂ +w/2	15,1	39,2	40	50	34	04

Weitere Abmessungen auf Anfrage
Further sizes upon request

w siehe WSP
w see indexable inserts

Abmessungen in mm
Dimensions in mm

Das Anzugsdrehmoment der Schraube für w = 2,0 mm ist 2,5 Nm
Das Anzugsdrehmoment der Schraube für w = 3,0 mm ist 3,0 Nm
Das Anzugsdrehmoment der Schraube für w = 4,0 mm ist 3,5 Nm

Torque specification of the screw for w = 2,0 mm is 2,5 Nm
Torque specification of the screw for w = 3,0 mm is 3,0 Nm
Torque specification of the screw for w = 4,0 mm is 3,5 Nm

Hinweis:
für Kassettensitz System 220!
Note:
for use with pocket seat system 220!

Ersatzteile

Spare Parts

Kassette Cassette	Spannschraube Screw	TORX PLUS®-Schlüssel TORX PLUS® Wrench
R/LAK25A...	5.13 T20P	T20PQ

Axialeinstechen

Face Grooving



Klemmhalter

Toolholder

IB25A

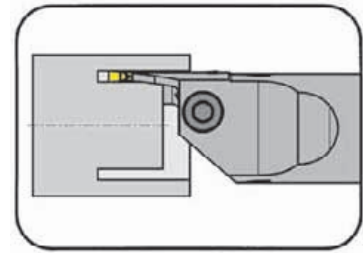

Nutaußen-Ø ab	from outer groove Ø	20 mm
Stechtiefe bis	Depth of groove up to	20 mm
Stechbreite	Width of groove	2,0 - 4,0 mm

Wendeschneidplatte
Indexable insert

Typ S15A
Type S25A

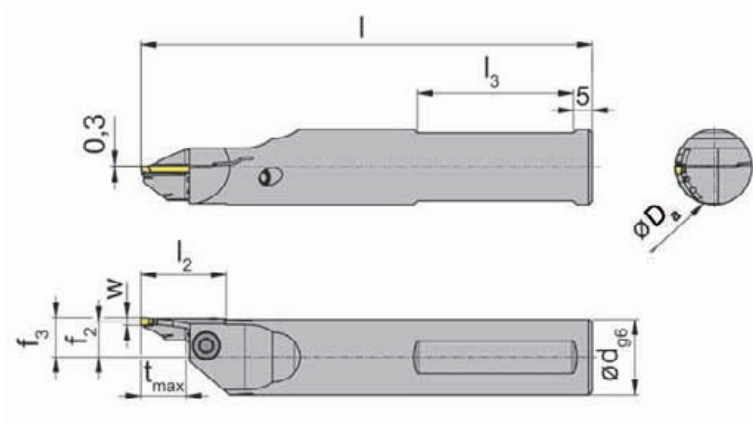

Spitzenhöhe liegt 0,3 mm
über Drehmitte
The cutting edge must be set
0.3 mm above centre height

L = links wie gezeichnet
L = left hand version shown

R = rechts spiegelbildlich
R = right hand version

Bestellnummer Part number	d	l	l ₂	l ₃	t _{max}	f ₃	f ₂	D _{a min}	D _{a max}	Schneidbreite Width of groove
R/LIB25A.20.2025.02.IK	20	120	23	55	12	f ₂ +w/2	9,5	20	25	2
R/LIB25A.20.2530.02.IK	20	120	23	55	13	f ₂ +w/2	9,5	25	30	2
R/LIB25A.20.2025.03.IK	20	120	24	55	14	f ₂ +w/2	9,0	20	25	3
R/LIB25A.20.2530.03.IK	20	120	25	55	15	f ₂ +w/2	9,0	25	30	3
R/LIB25A.20.3040.03.IK	20	120	27	55	16	f ₂ +w/2	9,0	30	40	3
R/LIB25A.20.4050.03.IK	20	120	30	55	18	f ₂ +w/2	9,0	40	50	3
R/LIB25A.20.2025.04.IK	20	120	26	55	16	f ₂ +w/2	8,5	20	25	4
R/LIB25A.20.2530.04.IK	20	120	27	55	17	f ₂ +w/2	8,5	25	30	4
R/LIB25A.20.3040.04.IK	20	120	29	55	18	f ₂ +w/2	8,5	30	40	4
R/LIB25A.20.4050.04.IK	20	120	31	55	20	f ₂ +w/2	8,5	40	50	4

Weitere Abmessungen auf Anfrage
Further sizes upon request

w siehe WSP
w see indexable inserts

Abmessungen in mm
Dimensions in mm

Das Anzugsdrehmoment der Schraube für w = 2,0 mm ist 2,5 Nm
Das Anzugsdrehmoment der Schraube für w = 3,0 mm ist 3,0 Nm
Das Anzugsdrehmoment der Schraube für w = 4,0 mm ist 3,5 Nm

Torque specification of the screw for w = 2,0 mm is 2,5 Nm
Torque specification of the screw for w = 3,0 mm is 3,0 Nm
Torque specification of the screw for w = 4,0 mm is 3,5 Nm

Ersatzteile

Spare Parts

Klemmhalter Toolholder	Spannschraube Screw	TORX PLUS®-Schlüssel TORX PLUS® Wrench
R/LIB25A...	5.13T20EP	T20PQ

Axialeinstechen

Face Grooving



Schneidplatte

Insert

S15A

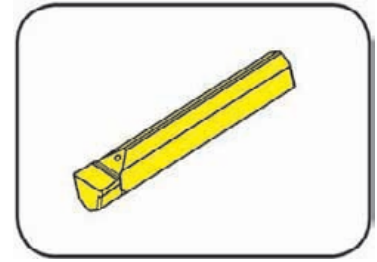

Stechbreite	Width of groove	2-4 mm
-------------	-----------------	--------

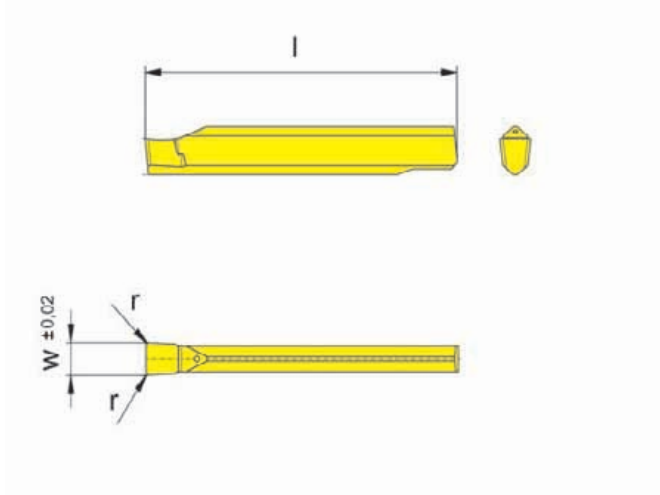

Klemmhalter
Toolholder

Typ H25A
Type K25A
IB25A

Wechselgenauigkeit
Länge ± 0,025 mm
Indexability length ± 0,025 mm

Bestellnummer Part number	w	r	l	Größe Size	TH35
S15A.0200.12	2	0,2	20	02	▲
S15A.0300.12	3	0,2	21	03	▲
S15A.0400.12	4	0,2	24	04	▲
					P •
					M •
					K •
					N •
					S •
					H -

▲ ab Lager / on stock Δ 4 Wochen / 4 weeks x auf Anfrage / upon request

● empfohlen / recommended

o bedingt einsetzbar / alternative recommendation

- nicht geeignet / not suitable

□ unbeschichtete HM-Sorten / uncoated grades

■ beschichtete HM-Sorten / coated grades

■ bestückt/Cermet / brazed/Cermet

Abmessungen in mm

Dimensions in mm

Schneidplatten sind in **rechten und linken** Klemmhaltern verwendbar.

Indexable inserts can be used in **right and left** hand toolholders.

HM-Sorten
Carbide grades



Axialeinstechen

Face Grooving



Schneidplatte

Insert

S15A

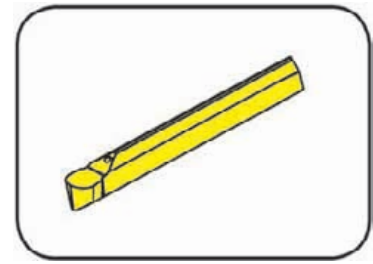

Vollradius	Full radius	1-2 mm
Stechbreite	Width of groove	2-4 mm

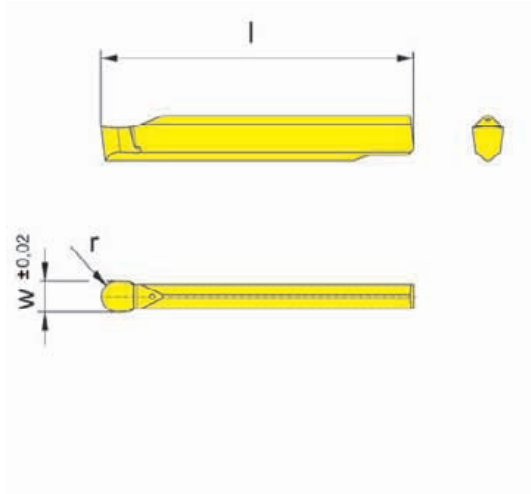

Klemmhalter
Toolholder

Typ H25A
Type K25A
IB25A

Wechselgenauigkeit
Länge $\pm 0,025$ mm
Indexability length $\pm 0,025$ mm

Bestellnummer Part number	w	l	r	Größe Size	TH35
S15A.0200.10.10	2	20	1,0	02	▲
S15A.0300.10.15	3	21	1,5	03	▲
S15A.0400.10.20	4	24	2,0	04	▲
					P •
					M •
					K •
					N •
					S •
					H -

▲ ab Lager / on stock Δ 4 Wochen / 4 weeks x auf Anfrage / upon request

● empfohlen / recommended

o bedingt einsetzbar / alternative recommendation

- nicht geeignet / not suitable

□ unbeschichtete HM-Sorten / uncoated grades

■ beschichtete HM-Sorten / coated grades

■ bestückt/Cermet / brazed/Cermet

Abmessungen in mm

Dimensions in mm

Schneidplatten sind in **rechten und linken** Klemmhaltern verwendbar.

Indexable inserts can be used in **right and left** hand toolholders.

HM-Sorten
Carbide grades

Axialeinstechen

Face Grooving



Schneidplatte

Insert

S15A

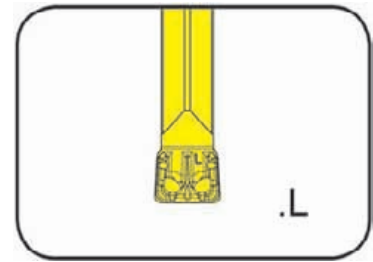

Stechbreite	Width of groove	4 mm
-------------	-----------------	------

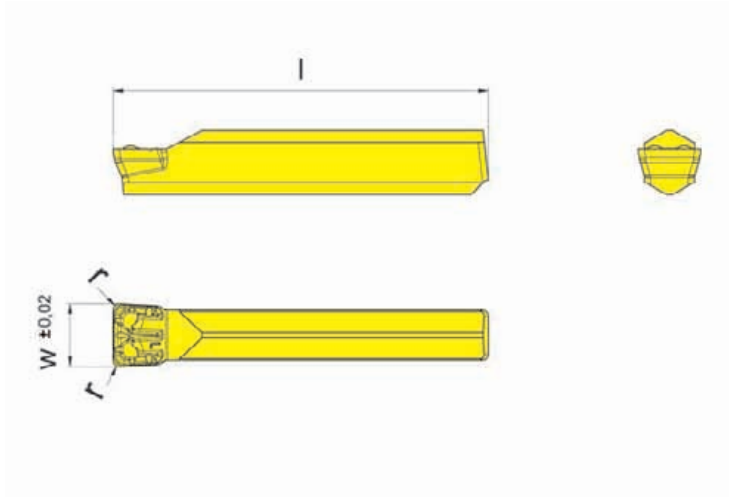

Klemmhalter
Toolholder

Typ H25A
Type K25A
IB25A

Wechselgenauigkeit
Länge ± 0,025 mm
Indexability length ± 0,025 mm

Bestellnummer Part number	w	r	l	Größe Size	AS45
S15A.0400.L4	4	0,4	24	04	▲

- ▲ ab Lager / on stock Δ 4 Wochen / 4 weeks x auf Anfrage / upon request
- empfohlen / recommended
- o bedingt einsetzbar / alternative recommendation
- nicht geeignet / not suitable
- unbeschichtete HM-Sorten / uncoated grades
- beschichtete HM-Sorten / coated grades
- bestückt/Cermet / brazed/Cermet

Abmessungen in mm
Dimensions in mm

Schneidplatten sind in **rechten und linken** Klemmhaltern verwendbar.
Indexable inserts can be used in **right and left** hand toolholders.

HM-Sorten
Carbide grades

P	●
M	●
K	●
N	○
S	●
H	-



Axialeinstechen

Face Grooving



Wendeschneidplatte

Indexable insert

S25A

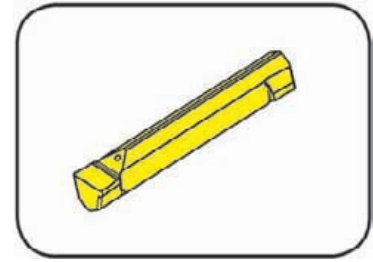

Stechbreite	Width of groove	2-4 mm
-------------	-----------------	--------

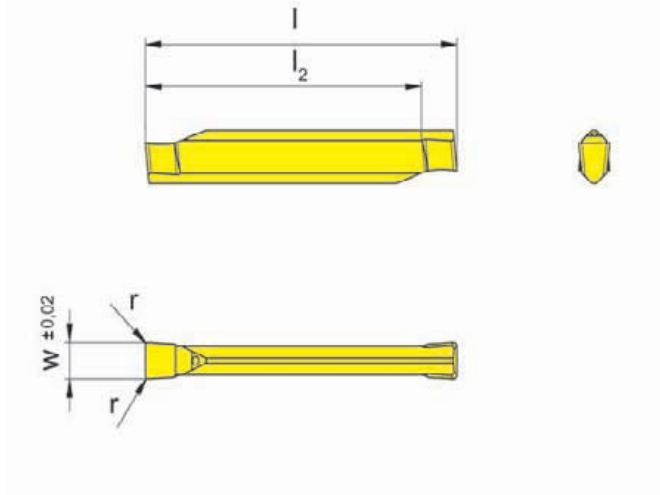

Klemmhalter
Toolholder

Typ H25A
Type K25A
IB25A

Wechselgenauigkeit
Länge ± 0,025 mm
Indexability length ± 0,025 mm

Bestellnummer Part number	w	r	l	l ₂	Größe Size	TH35
S25A.0200.12	2	0,2	20	17,0	02	▲
S25A.0300.12	3	0,2	21	18,0	03	▲
S25A.0400.12	4	0,2	24	20,5	04	▲

▲ ab Lager / on stock Δ 4 Wochen / 4 weeks x auf Anfrage / upon request

● empfohlen / recommended

o bedingt einsetzbar / alternative recommendation

- nicht geeignet / not suitable

□ unbeschichtete HM-Sorten / uncoated grades

■ beschichtete HM-Sorten / coated grades

■ bestückt/Cermet / brazed/Cermet

Abmessungen in mm

Dimensions in mm

Wendeschneidplatten sind in rechten und linken Klemmhaltern verwendbar.

Indexable inserts can be used in right and left hand toolholders.

P	•
M	•
K	•
N	•
S	•
H	-

HM-Sorten
Carbide grades

Axialeinstechen

Face Grooving



Wendeschneidplatte

Indexable insert

S25A

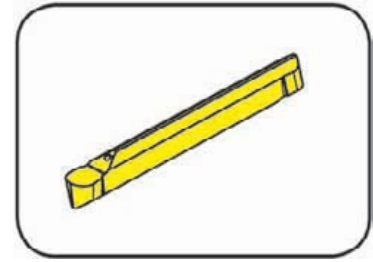

Vollradius	Full radius	1-2 mm
Stechbreite	Width of groove	2-4 mm

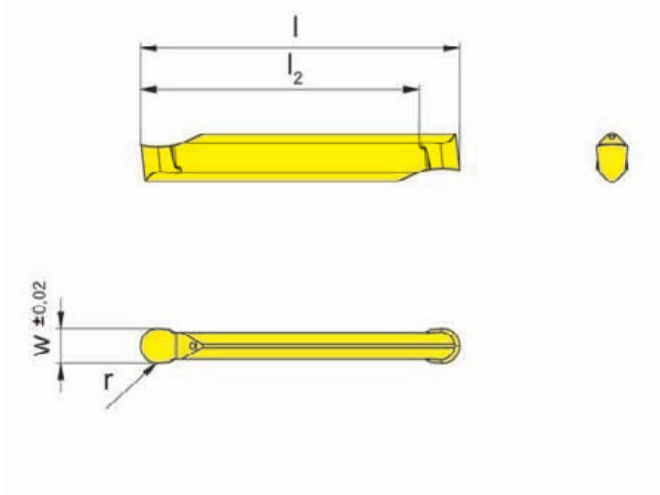

Klemmhalter
Toolholder

Typ H25A
Type K25A
IB25A

Wechselgenauigkeit
Länge ± 0,025 mm
Indexability length ± 0,025 mm

Bestellnummer Part number	w	l	r	l ₂	Größe Size	TH35
S25A.0200.10.10	2	20	1,0	17,0	02	▲
S25A.0300.10.15	3	21	1,5	18,0	03	▲
S25A.0400.10.20	4	24	2,0	20,5	04	▲

▲ ab Lager / on stock Δ 4 Wochen / 4 weeks x auf Anfrage / upon request

● empfohlen / recommended

o bedingt einsetzbar / alternative recommendation

- nicht geeignet / not suitable

□ unbeschichtete HM-Sorten / uncoated grades

■ beschichtete HM-Sorten / coated grades

■ bestückt/Cermet / brazed/Cermet

Abmessungen in mm

Dimensions in mm

Wendeschneidplatten sind in rechten und linken Klemmhaltern verwendbar.

Indexable inserts can be used in right and left hand toolholders.

P	•
M	•
K	•
N	•
S	•
H	-

HM-Sorten
Carbide grades



Grundhalter
Basic toolholder
System220/220/B224

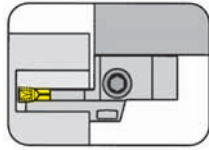

Seite/Page
S46-S47, S50

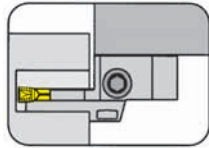

Seite/Page
S48-S49

Kassette
Cassette
LAK224/RAK224/
LIK224/RIK224

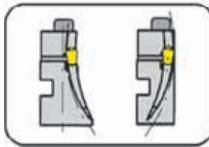

Seite/Page
S51-S58

Wendeschneidplatte
Indexable insert
S224

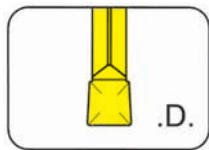

Seite/Page
S59

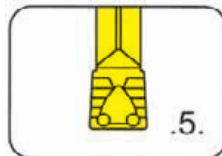

Seite/Page
S60

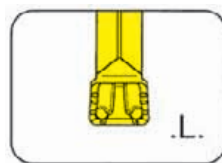

Seite/Page
S601

S

224



S

**Klemmhalter mit
Schneidplatten**

Stechbreite 3 - 6 mm

**Toolholder with
Inserts**

Width of groove 3 - 6 mm

Axialeinstechen

Face Grooving



Grundhalter

Basic toolholder

220

ohne Kassette
without cassette

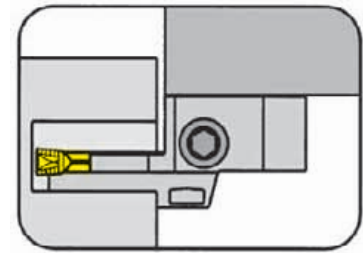

Grundhalter für Kassetten Typ 220/224
Basic toolholder for cassettes type 220/224

Schaft parallel zur Drehachse
Shank parallel to the axis of workpiece

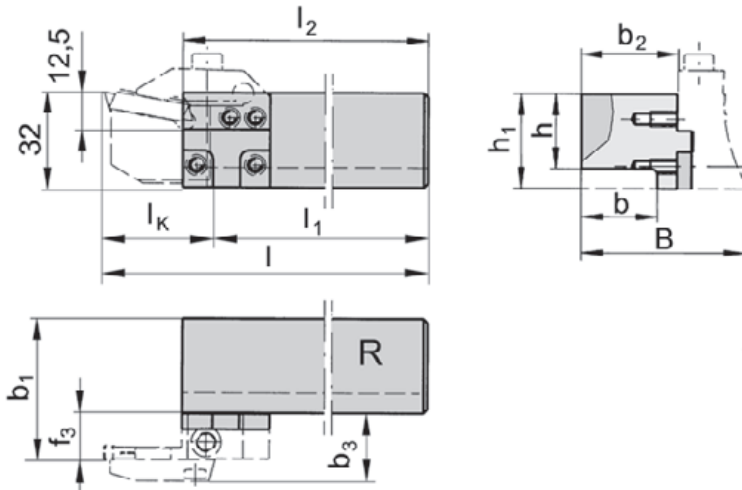

R = rechts wie gezeichnet
R = right hand version shown

L = Linksausführung
L = left hand version

Bestellnummer Part number	h	h ₁	l ₁	b	b ₁	b ₂	l ₂	l	B
R/L220.1616.K1	16	32	l ₂ -10	16	b ₂ +f ₃	25	64	l ₁ +l _K	b ₂ +b ₃
R/L220.2020.K1	20	32	l ₂ -10	20	b ₂ +f ₃	27	74	l ₁ +l _K	b ₂ +b ₃
R/L220.2525.K1	25	32	l ₂ -10	25	b ₂ +f ₃	32	94	l ₁ +l _K	b ₂ +b ₃
R/L220.3225.K1	32	32	l ₂ -10	-	b ₂ +f ₃	25	109	l ₁ +l _K	b ₂ +b ₃
R/L220.3232.K1	32	32	l ₂ -10	-	b ₂ +f ₃	32	109	l ₁ +l _K	b ₂ +b ₃

Ausführung R oder L angeben
State R or L version

l_K, b₃ und f₃ siehe Kassetten
l_K, b₃ and f₃ see cassettes

Abmessungen in mm
Dimensions in mm

Weitere Abmessungen auf Anfrage
Further sizes upon request

Rechte Grundhalter für rechte Kassetten und linke Grundhalter für linke Kassetten verwenden.
Use right hand basic toolholder for right hand cassettes and left hand basic toolholder for left hand cassettes.

Ersatzteile

Spare Parts

Grundhalter Basic toolholder	Spannschraube Screw	TORX PLUS®-Schlüssel TORX PLUS® Wrench
L220.1616.K1	5.12T20P	T20PQ

Axialeinstechen

Face Grooving



Grundhalter

Basic toolholder

220

ohne Kasette
without cassette

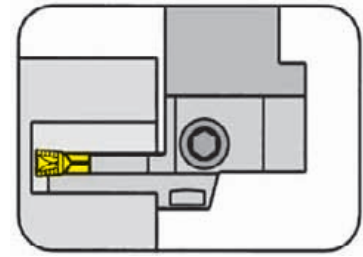

Grundhalter für Kassetten Typ 220/224
Basic toolholder for cassettes type 220/224

Schaft 90° zur Drehachse
Shank 90° to the axis of workpiece

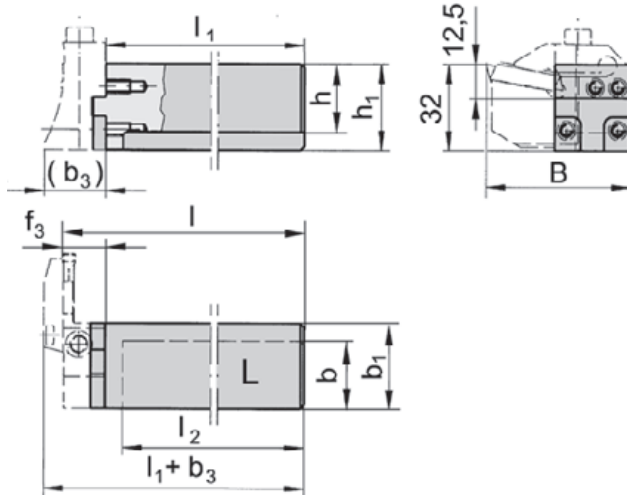

L = links wie gezeichnet
L = left hand version shown

R = Rechtsausführung
R = right hand version

Bestellnummer Part number	h	h ₁	b	l ₂	l	B	b ₁	l ₁
R/L220.1616.K2	16	32	16	60	l ₁ +f ₃	l _k +19	29	70
R/L220.2020.K2	20	32	20	75	l ₁ +f ₃	l _k +19	29	85
R/L220.2525.K2	25	32	25	93	l ₁ +f ₃	l _k +22	32	100
R/L220.3225.K2	32	32	-	108	l ₁ +f ₃	l _k +19	29	115
R/L220.3232.K2	32	32	-	115	l ₁ +f ₃	l _k +22	32	115

Ausführung R oder L angeben
State R or L version

l_k, b₃ und f₃ siehe Kassetten
l_k, b₃ and f₃ see cassettes

Abmessungen in mm
Dimensions in mm

Weitere Abmessungen auf Anfrage
Further sizes upon request

Rechte Grundhalter für linke Kassetten und linke Grundhalter für rechte Kassetten verwenden.
Use right hand basic toolholder for left hand cassettes and left hand basic toolholder for right hand cassettes.

Ersatzteile

Spare Parts

Grundhalter Basic toolholder	Spannschraube Screw	TORX PLUS®-Schlüssel TORX PLUS® Wrench
R/L220...	5.12T20P	T20PQ

Axialeinstechen

Face Grooving



Grundhalter

Basic toolholder

220

ohne Kasette
without cassette

passend für HORN VDI-Aufnahmen mit integrierter Innenkühlung
suitable for HORN adaptors VDI with integrated through coolant supply

Schaft parallel zur Drehachse
Shank parallel to the axis of workpiece

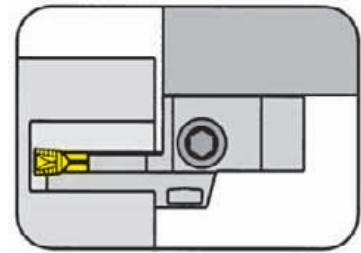

für Kasette
for Cassette

Typ 220
Type 224

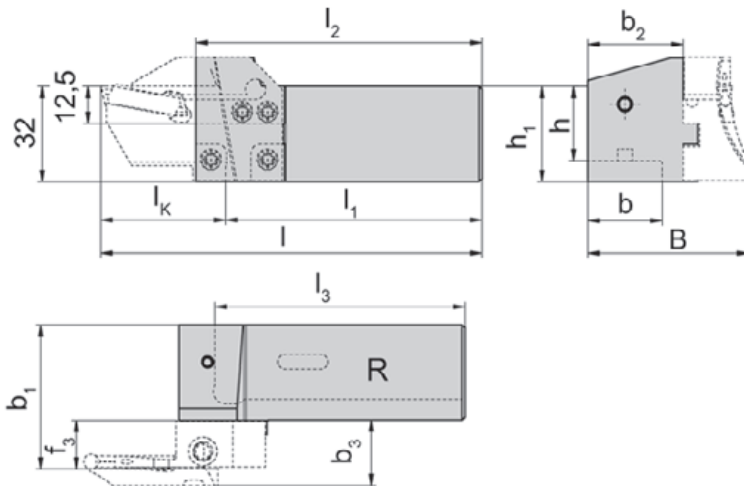

R = rechts wie gezeichnet
R = right hand version shown

L = Linksausführung
L = left hand version

mit integrierter innerer
Kühlmittelzufuhr
with integrated through
coolant supply

Bestellnummer Part number	h	h ₁	l ₁	b	b ₁	b ₂	l ₂	l	B
R/L220.2020.2.K1.IK	20	32	l ₂ -10	20	b ₂ +f ₃	27	84	l ₁ +l _k	b ₂ +b ₃
R/L220.2525.2.K1.IK	25	32	l ₂ -10	25	b ₂ +f ₃	32	96	l ₁ +l _k	b ₂ +b ₃

Ausführung R oder L angeben
State R or L version

l_k, b₃ und f₃ siehe Kassetten
l_k, b₃ and f₃ see cassettes

Abmessungen in mm
Dimensions in mm

Weitere Abmessungen auf Anfrage
Further sizes upon request

Rechte Grundhalter für rechte Kassetten und linke Grundhalter für linke Kassetten verwenden.
Use right hand basic toolholder for right hand cassettes and left hand basic toolholder for left hand cassettes.

Ersatzteile

Spare Parts

Grundhalter Basic toolholder	Spannschraube Screw	TORX PLUS®-Schlüssel TORX PLUS® Wrench
L220...	5.12T20P	T20PQ

Axialeinstechen

Face Grooving



Grundhalter

Basic toolholder

220
ohne Kasette
without cassette

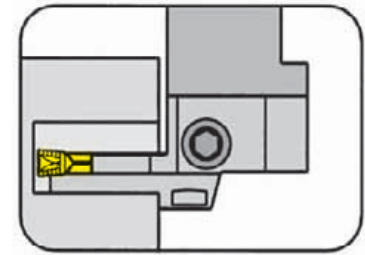

passend für HORN VDI-Aufnahmen mit integrierter Innenkühlung
suitable for HORN adaptors VDI with integrated through coolant supply

Schaft 90° zur Drehachse
Shank 90° to the axis of workpiece

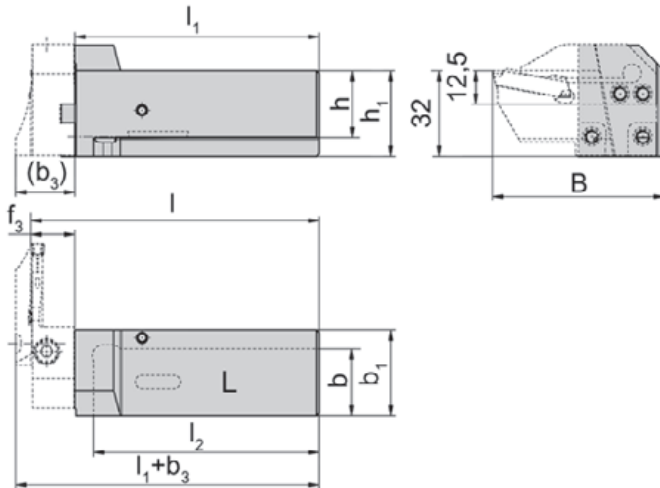

L = links wie gezeichnet
L = left hand version shown

R = Rechtsausführung
R = right hand version

für Kasette
for Cassette

Typ 220
Type 224

mit integrierter innerer
Kühlmittelzufuhr
with integrated through
coolant supply

Bestellnummer Part number	h	h ₁	b	l ₂	l	B	b ₁	l ₁
R/L220.2020.2.K2.IK	20	32	20	69	l ₁ +f ₃	l _k +19	29	79
R/L220.2525.2.K2.IK	25	32	25	84	l ₁ +f ₃	l _k +19	32	91

Ausführung R oder L angeben
State R or L version

l_k, b₃ und f₃ siehe Kassetten
l_k, b₃ and f₃ see cassettes

Abmessungen in mm
Dimensions in mm

Weitere Abmessungen auf Anfrage
Further sizes upon request

Rechte Grundhalter für linke Kassetten und linke Grundhalter für rechte Kassetten verwenden.
Use right hand basic toolholder for left hand cassettes and left hand basic toolholder for right hand cassettes.

Ersatzteile

Spare Parts

Grundhalter Basic toolholder	Spannschraube Screw	TORX PLUS®-Schlüssel TORX PLUS® Wrench
R/L220...	5.12T20P	T20PQ

Axialeinstechen

Face Grooving



Grundhalter

Basic toolholder

B224

ohne Kasette
without cassette

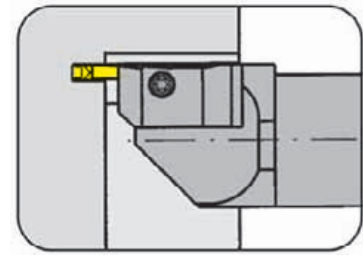

Grundhalter für Kassetten Typ RIK/LIK224
Basic toolholder for cassettes type RIK/LIK224

mit innerer Kühlmittelzufuhr
with through coolant supply

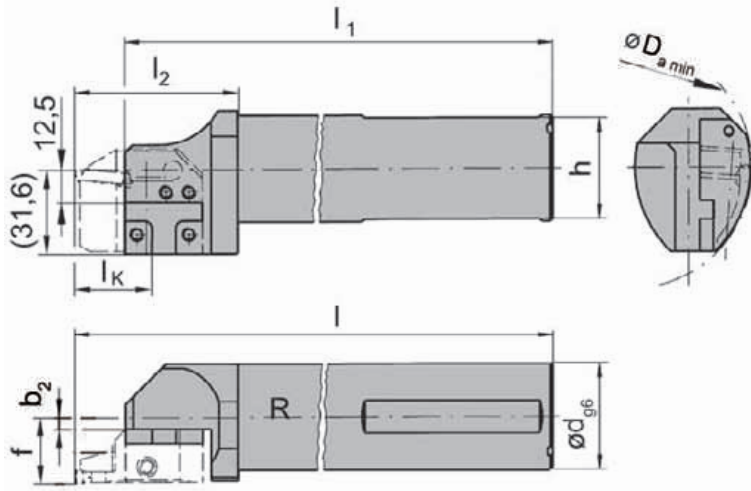

für Kasette
for Cassette

Typ R/LIK224
Type

R = rechts wie gezeichnet
R = right hand version shown

L = Linksausführung
L = left hand version

Bestellnummer Part number	d	l ₁	h	f	l ₂	b ₂	l	D _{Bohr}
R/LB224.0032.K1	32	181	30	b ₂ +f ₃	59	0,41	200	90
R/LB224.0040.K1	40	231	38	b ₂ +f ₃	59	4,41	250	90

Ausführung R oder L angeben
State R or L version

D_{a min} / f₃ / l_k siehe Kassetten
D_{a min} / f₃ / l_k see cassettes

Abmessungen in mm
Dimensions in mm

Weitere Abmessungen auf Anfrage
Further sizes upon request

Ersatzteile

Spare Parts

Grundhalter Basic toolholder	Spannschraube Screw	TORX PLUS®-Schlüssel TORX PLUS® Wrench
R/LB224...	5.12T20P	T20PQ

Axialeinstechen

Face Grooving



Kassette

Cassette

LAK224

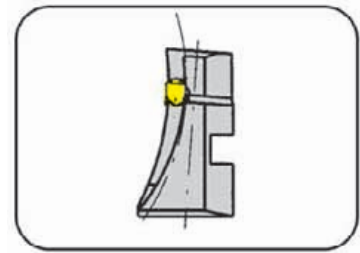

Nutaußen-Ø
Stechtiefe bis
Stechbreite

Nutaußen-Ø
Depth of groove up to
Width of groove

38 - 1000 mm
14 mm
3 - 4 mm

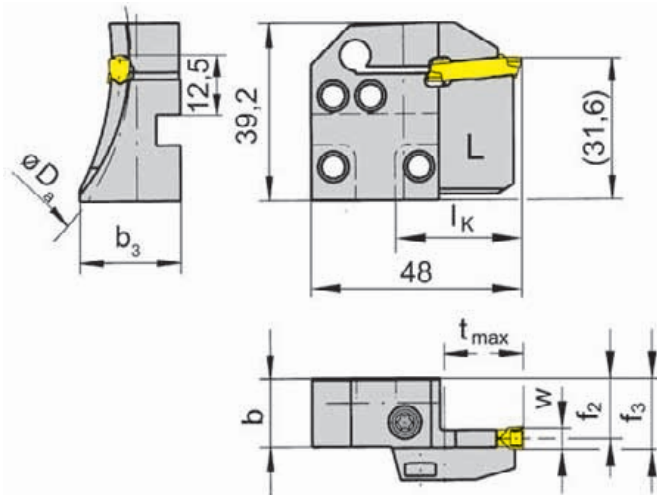

L = Linksausführung
L = left hand version

für Wendeschneidplatte
for Indexable insert

Typ S224
Type

Bestellnummer Part number	$D_{a \min}$	$D_{a \max}$	t_{\max}	b	b_3	f_2	f_3	w	l_K
LAK224.5060.03	50	60	14	15,7	21,0	14,9	$f_2+w/2$	3	29
LAK224.6075.03	60	75	14	15,7	21,0	14,9	$f_2+w/2$	3	29
LAK224.7590.03	75	90	14	15,7	21,0	14,9	$f_2+w/2$	3	29
LAK224.9011.03	90	110	14	15,7	21,0	14,9	$f_2+w/2$	3	29
LAK224.1113.03	110	130	14	15,7	21,0	14,9	$f_2+w/2$	3	29
LAK224.1318.03	130	180	14	15,7	20,0	14,9	$f_2+w/2$	3	29
LAK224.1830.03	180	300	14	15,7	19,0	14,9	$f_2+w/2$	3	29
LAK224.3000.03	300	1000	14	15,7	16,4	14,9	$f_2+w/2$	3	29
LAK224.3847.04	38	60	14	15,7	21,0	14,4	$f_2+w/2$	4	29
LAK224.4760.04	47	75	14	15,7	21,0	14,4	$f_2+w/2$	4	29
LAK224.6075.04	60	90	14	15,7	21,0	14,4	$f_2+w/2$	4	29
LAK224.7590.04	75	110	14	15,7	21,0	14,4	$f_2+w/2$	4	29
LAK224.9013.04	90	130	14	15,7	21,0	14,4	$f_2+w/2$	4	29
LAK224.1318.04	130	180	14	15,7	21,0	14,4	$f_2+w/2$	4	29
LAK224.1830.04	180	300	14	15,7	19,0	14,4	$f_2+w/2$	4	29
LAK224.3000.04	300	1000	14	15,7	16,7	14,4	$f_2+w/2$	4	29

Für Grundhalter L...K1 und R...K2
For basic toolholder L...K1 and R...K2

Weitere Abmessungen auf Anfrage
Further sizes upon request

Abmessungen in mm
Dimensions in mm

Bestellhinweis:

Befestigungsschrauben der Kassetten gehören zum Lieferumfang des Grundhalters.

Ordering note:

The fastening screw is combined with the basic toolholder - no separate order required.

Das Anzugsdrehmoment der Schrauben finden Sie in den Technischen Hinweisen.

For torque specification of the screw, please see Technical Instructions.

Ersatzteile

Spare Parts

Kassette Cassette	Spannschraube Screw	TORX PLUS®-Schlüssel TORX PLUS® Wrench
LAK224...	5.13 T20P	T20PQ

Axialeinstechen

Face Grooving



Kassette

Cassette

LAK224

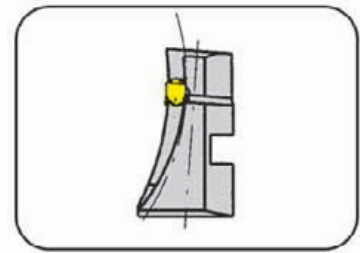

Nutaußen-Ø
Stechtiefe bis
Stechbreite

Nutaußen-Ø
Depth of groove up to
Width of groove

38 - 1000 mm
14 mm
5 - 6 mm

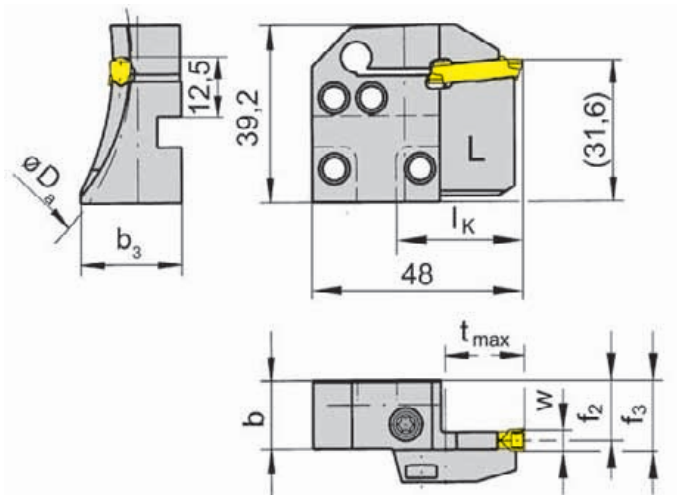

für Wendeschneidplatte
for Indexable insert

Typ S224
Type

L = Linksausführung
L = left hand version

Bestellnummer Part number	D _{a min}	D _{a max}	t _{max}	b	b ₃	f ₂	f ₃	w	l _k
LAK224.3847.05	38	47	14	15,7	21,0	13,9	f ₂ +w/2	5	29
LAK224.4760.05	47	60	14	15,7	21,0	13,9	f ₂ +w/2	5	29
LAK224.6075.05	60	75	14	15,7	21,0	13,9	f ₂ +w/2	5	29
LAK224.7590.05	75	90	14	15,7	21,0	13,9	f ₂ +w/2	5	29
LAK224.9013.05	90	130	14	15,7	21,0	13,9	f ₂ +w/2	5	29
LAK224.1318.05	130	180	14	15,7	21,0	13,9	f ₂ +w/2	5	29
LAK224.1830.05	180	300	14	15,7	19,0	13,9	f ₂ +w/2	5	29
LAK224.3000.05	300	1000	14	15,7	16,7	13,9	f ₂ +w/2	5	29
LAK224.6075.06	60	75	14	15,7	23,0	13,4	f ₂ +w/2	6	29
LAK224.7590.06	75	90	14	15,7	23,0	13,4	f ₂ +w/2	6	29
LAK224.9013.06	90	130	14	15,7	21,0	13,4	f ₂ +w/2	6	29
LAK224.1318.06	130	180	14	15,7	21,0	13,4	f ₂ +w/2	6	29
LAK224.1830.06	180	300	14	15,7	19,0	13,4	f ₂ +w/2	6	29
LAK224.3000.06	300	1000	14	15,7	16,7	13,4	f ₂ +w/2	6	29

Für Grundhalter L...K1 und R...K2
For basic toolholder L...K1 and R...K2

Weitere Abmessungen auf Anfrage
Further sizes upon request

Abmessungen in mm
Dimensions in mm

Bestellhinweis:

Befestigungsschrauben der Kassetten gehören zum Lieferumfang des Grundhalters.

Ordering note:

The fastening screw is combined with the basic toolholder - no separate order required.

Das Anzugsdrehmoment der Schrauben finden Sie in den Technischen Hinweisen.

For torque specification of the screw, please see Technical Instructions.

Ersatzteile

Spare Parts

Kassette Cassette	Spannschraube Screw	TORX PLUS®-Schlüssel TORX PLUS® Wrench
LAK224...	5.13 T20P	T20PQ

Axialeinstechen

Face Grooving



Kassette

Cassette

RAK224

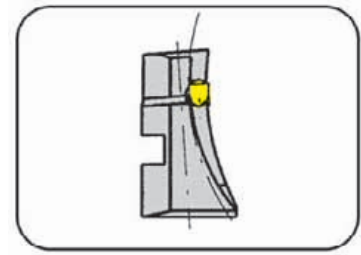

Nutaußen-Ø	Nutaußen-Ø	38 - 1000 mm
Stechtiefe bis	Depth of groove up to	14 mm
Stechbreite	Width of groove	3 - 4 mm

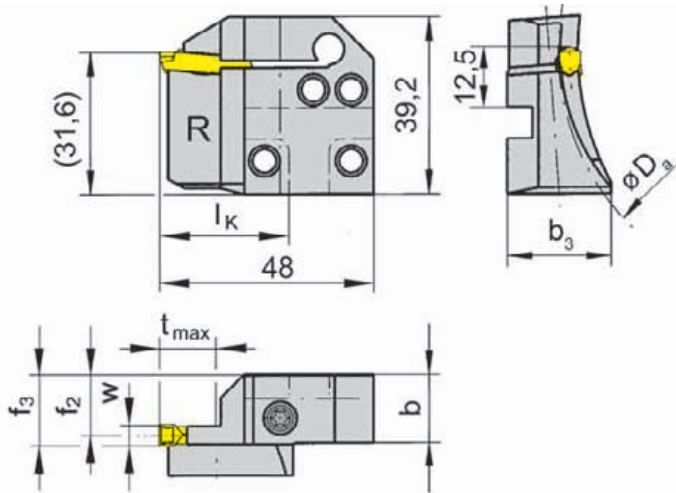

für Wendeschneidplatte
for Indexable insert

Typ S224
Type

R = Rechtsausführung
R = right hand version

Bestellnummer Part number	D _{a min}	D _{a min2}	t _{max}	b	b ₃	f ₂	f ₃	w	l _k
RAK224.5060.03	50	60	14	15,7	21,0	14,9	f ₂ +w/2	3	29
RAK224.6075.03	60	75	14	15,7	21,0	14,9	f ₂ +w/2	3	29
RAK224.7590.03	75	90	14	15,7	21,0	14,9	f ₂ +w/2	3	29
RAK224.9011.03	90	110	14	15,7	21,0	14,9	f ₂ +w/2	3	29
RAK224.1113.03	110	130	14	15,7	21,0	14,9	f ₂ +w/2	3	29
RAK224.1318.03	130	180	14	15,7	20,0	14,9	f ₂ +w/2	3	29
RAK224.1830.03	180	300	14	15,7	19,0	14,9	f ₂ +w/2	3	29
RAK224.3000.03	300	1000	14	15,7	16,4	14,9	f ₂ +w/2	3	29
RAK224.3847.04	38	47	14	15,7	21,0	14,4	f ₂ +w/2	4	29
RAK224.4760.04	47	60	14	15,7	21,0	14,4	f ₂ +w/2	4	29
RAK224.6075.04	60	75	14	15,7	21,0	14,4	f ₂ +w/2	4	29
RAK224.7590.04	75	90	14	15,7	21,0	14,4	f ₂ +w/2	4	29
RAK224.9013.04	90	130	14	15,7	21,0	14,4	f ₂ +w/2	4	29
RAK224.1318.04	130	180	14	15,7	21,0	14,4	f ₂ +w/2	4	29
RAK224.1830.04	180	300	14	15,7	19,0	14,4	f ₂ +w/2	4	29
RAK224.3000.04	300	1000	14	15,7	16,7	14,4	f ₂ +w/2	4	29

Für Grundhalter R...K1 und L...K2
For basic toolholder R...K1 and L...K2

Weitere Abmessungen auf Anfrage
Further sizes upon request

Abmessungen in mm
Dimensions in mm

Bestellhinweis:

Befestigungsschrauben der Kassetten gehören zum Lieferumfang des Grundhalters.

Ordering note:

The fastening screw is combined with the basic toolholder - no separate order required.

Das Anzugsdrehmoment der Schrauben finden Sie in den Technischen Hinweisen.

For torque specification of the screw, please see Technical Instructions.

Ersatzteile

Spare Parts

Kassette Cassette	Spannschraube Screw	TORX PLUS®-Schlüssel TORX PLUS® Wrench
RAK224...	5.13 T20P	T20PQ

Axialeinstechen

Face Grooving



Kassette

Cassette

RAK224

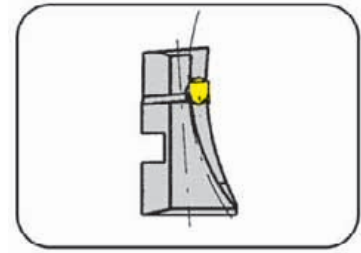

Nutaußen-Ø	Nutaußen-Ø	38 - 1000 mm
Stechtiefe bis	Depth of groove up to	14 mm
Stechbreite	Width of groove	5 - 6 mm

für Wendeschneidplatte
for Indexable insert

Typ S224
Type

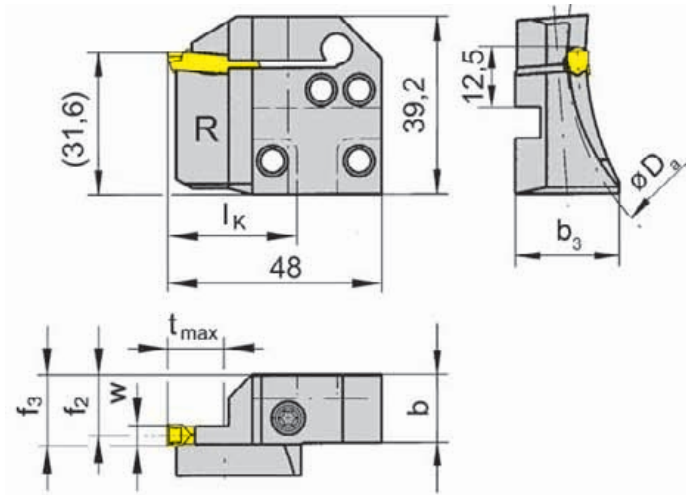

R = Rechtsausführung
R = right hand version

Bestellnummer Part number	D _{a min}	D _{a min2}	t _{max}	b	b ₃	f ₂	f ₃	w	l _k
RAK224.3847.05	38	47	14	15,7	21,0	13,9	f ₂ +w/2	5	29
RAK224.4760.05	47	60	14	15,7	21,0	13,9	f ₂ +w/2	5	29
RAK224.6075.05	60	75	14	15,7	21,0	13,9	f ₂ +w/2	5	29
RAK224.7590.05	75	90	14	15,7	21,0	13,9	f ₂ +w/2	5	29
RAK224.9013.05	90	130	14	15,7	21,0	13,9	f ₂ +w/2	5	29
RAK224.1318.05	130	180	14	15,7	21,0	13,9	f ₂ +w/2	5	29
RAK224.1830.05	180	300	14	15,7	19,0	13,9	f ₂ +w/2	5	29
RAK224.3000.05	300	1000	14	15,7	16,7	13,9	f ₂ +w/2	5	29
RAK224.6075.06	60	75	14	15,7	23,0	13,4	f ₂ +w/2	6	29
RAK224.7590.06	75	90	14	15,7	23,0	13,4	f ₂ +w/2	6	29
RAK224.9013.06	90	130	14	15,7	21,0	13,4	f ₂ +w/2	6	29
RAK224.1318.06	130	180	14	15,7	21,0	13,4	f ₂ +w/2	6	29
RAK224.1830.06	180	300	14	15,7	19,0	13,4	f ₂ +w/2	6	29
RAK224.3000.06	300	1000	14	15,7	16,7	13,4	f ₂ +w/2	6	29

Für Grundhalter R...K1 und L...K2
For basic toolholder R...K1 and L...K2

Weitere Abmessungen auf Anfrage
Further sizes upon request

Abmessungen in mm
Dimensions in mm

Bestellhinweis:

Befestigungsschrauben der Kassetten gehören zum Lieferumfang des Grundhalters.

Ordering note:

The fastening screw is combined with the basic toolholder - no separate order required.

Das Anzugsdrehmoment der Schrauben finden Sie in den Technischen Hinweisen.

For torque specification of the screw, please see Technical Instructions.

Ersatzteile

Spare Parts

Kassette Cassette	Spannschraube Screw	TORX PLUS®-Schlüssel TORX PLUS® Wrench
RAK224...	5.13 T20P	T20PQ

Axialeinstechen

Face Grooving



Kassette

Cassette

LIK224

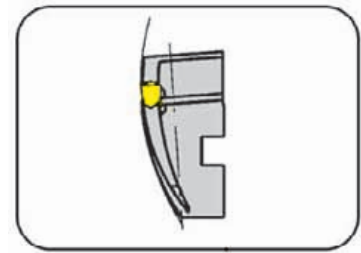

Nutaußen-Ø	Nutaußen-Ø	38 - 1000 mm
Stechtiefe bis	Depth of groove up to	14 mm
Stechbreite	Width of groove	3 - 4 mm

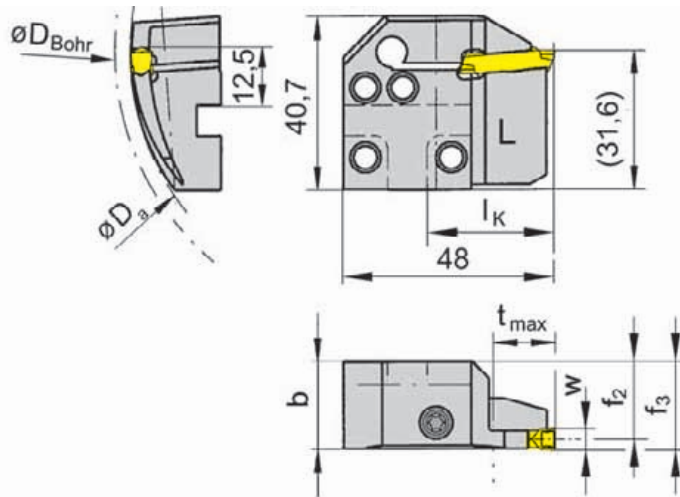

für Wendeschneidplatte
for Indexable insert

Typ S224
Type

L = Linksausführung
L = left hand version

Bestellnummer Part number	D _{a min}	D _{a min2}	t _{max}	b	f ₂	f ₃	w	l _k	D _{Bohr}
LIK224.5060.03	50	60	14	19	17,9	f ₂ +w/2	3	29	90
LIK224.6075.03	60	75	14	19	17,9	f ₂ +w/2	3	29	90
LIK224.7590.03	75	90	14	19	17,9	f ₂ +w/2	3	29	90
LIK224.9011.03	90	110	14	19	17,9	f ₂ +w/2	3	29	90
LIK224.1113.03	110	130	14	19	17,9	f ₂ +w/2	3	29	110
LIK224.1318.03	130	180	14	19	17,9	f ₂ +w/2	3	29	130
LIK224.1830.03	180	300	14	19	17,9	f ₂ +w/2	3	29	180
LIK224.3847.04	38	47	14	19	17,4	f ₂ +w/2	4	29	90
LIK224.4760.04	47	60	14	19	17,4	f ₂ +w/2	4	29	90
LIK224.6075.04	60	75	14	19	17,4	f ₂ +w/2	4	29	90
LIK224.7590.04	75	90	14	19	17,4	f ₂ +w/2	4	29	90
LIK224.9013.04	90	130	14	19	17,4	f ₂ +w/2	4	29	90
LIK224.1318.04	130	180	14	19	17,4	f ₂ +w/2	4	29	130
LIK224.3000.04	300	1000	14	19	17,4	f ₂ +w/2	4	29	300

Für Grundhalter L...K1 und R...K2
For basic toolholder L...K1 and R...K2

Weitere Abmessungen auf Anfrage
Further sizes upon request

Abmessungen in mm
Dimensions in mm

Bestellhinweis:

Befestigungsschrauben der Kassetten gehören zum Lieferumfang des Grundhalters.

Ordering note:

The fastening screw is combined with the basic toolholder - no separate order required.

Das Anzugsdrehmoment der Schrauben finden Sie in den Technischen Hinweisen.

For torque specification of the screw, please see Technical Instructions.

Ersatzteile

Spare Parts

Kassette Cassette	Spannschraube Screw	TORX PLUS®-Schlüssel TORX PLUS® Wrench
LIK224...	5.13 T20P	T20PQ

Axialeinstechen

Face Grooving



Kassette

Cassette

LIK224

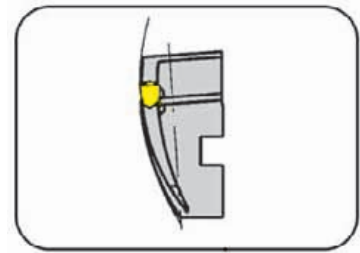

Nutaußen-Ø	Nutaußen-Ø	38 - 1000 mm
Stechtiefe bis	Depth of groove up to	14 mm
Stechbreite	Width of groove	5 - 6 mm

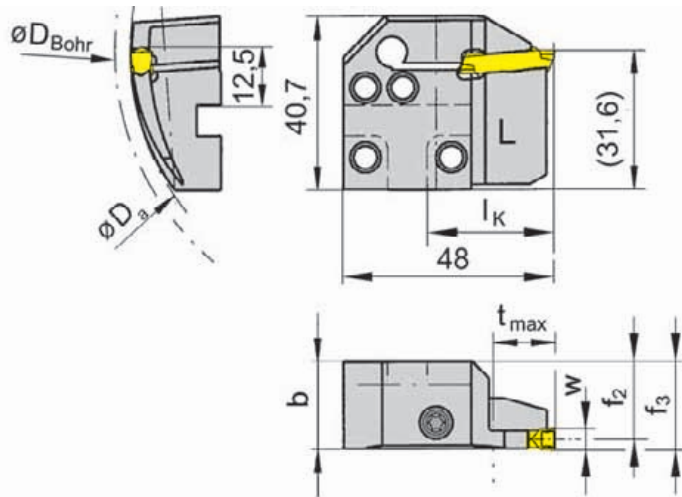

für Wendeschneidplatte
for Indexable insert

Typ S224
Type

L = Linksausführung
L = left hand version

Bestellnummer Part number	D _{a min}	D _{a min2}	t _{max}	b	f ₂	f ₃	w	l _k	D _{Bohr}
LIK224.3847.05	38	47	14	19	16,9	f ₂ +w/2	5	29	90
LIK224.4760.05	47	60	14	19	16,9	f ₂ +w/2	5	29	90
LIK224.6075.05	60	75	14	19	16,9	f ₂ +w/2	5	29	90
LIK224.7590.05	75	90	14	19	16,9	f ₂ +w/2	5	29	90
LIK224.9013.05	90	130	14	19	16,9	f ₂ +w/2	5	29	90
LIK224.1318.05	130	180	14	19	16,9	f ₂ +w/2	5	29	130
LIK224.1830.05	180	300	14	19	16,9	f ₂ +w/2	5	29	180
LIK224.3000.05	300	1000	14	19	16,9	f ₂ +w/2	5	29	300
LIK224.6075.06	60	75	14	19	16,4	f ₂ +w/2	6	29	90
LIK224.7590.06	75	90	14	19	16,4	f ₂ +w/2	6	29	90
LIK224.9013.06	90	130	14	19	16,4	f ₂ +w/2	6	29	90
LIK224.1318.06	130	180	14	19	16,4	f ₂ +w/2	6	29	130
LIK224.1830.06	180	300	14	19	16,4	f ₂ +w/2	6	29	180
LIK224.3000.06	300	1000	14	19	16,4	f ₂ +w/2	6	29	300

Für Grundhalter L...K1 und R...K2
For basic toolholder L...K1 and R...K2

Weitere Abmessungen auf Anfrage
Further sizes upon request

Abmessungen in mm
Dimensions in mm

Bestellhinweis:

Befestigungsschrauben der Kassetten gehören zum Lieferumfang des Grundhalters.

Ordering note:

The fastening screw is combined with the basic toolholder - no separate order required.

Das Anzugsdrehmoment der Schrauben finden Sie in den Technischen Hinweisen.

For torque specification of the screw, please see Technical Instructions.

Ersatzteile

Spare Parts

Kassette Cassette	Spannschraube Screw	TORX PLUS®-Schlüssel TORX PLUS® Wrench
LIK224...	5.13 T20P	T20PQ

Axialeinstechen

Face Grooving



Kassette

Cassette

RIK224

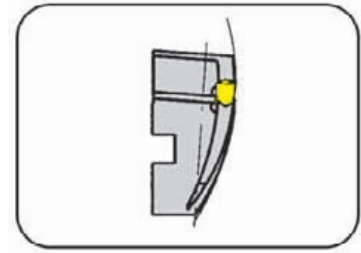

Nutaußen-Ø	Nutaußen-Ø	38 - 1000 mm
Stechtiefe bis	Depth of groove up to	14 mm
Stechbreite	Width of groove	3 - 4 mm

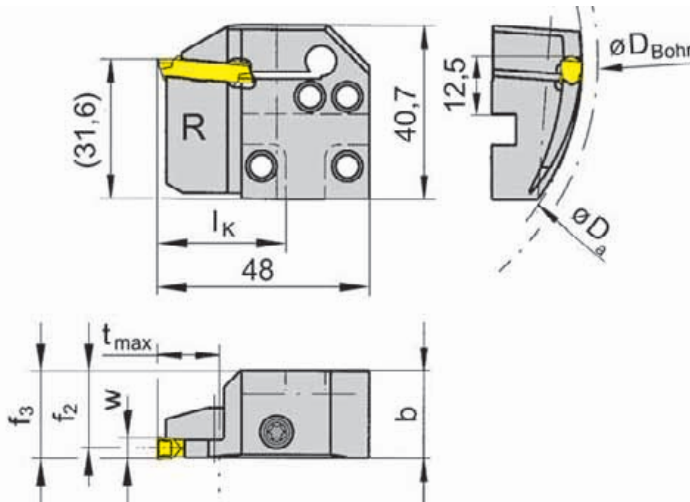

R = Rechtsausführung
R = right hand version

für Wendeschneidplatte
for Indexable insert

Typ S224
Type



Bestellnummer Part number	D _{a min}	D _{a min2}	t _{max}	b	f ₂	f ₃	w	l _k	D _{Bohr}
RIK224.5060.03	50	60	14	19	17,9	f ₂ +w/2	3	29	90
RIK224.6075.03	60	75	14	19	17,9	f ₂ +w/2	3	29	90
RIK224.7590.03	75	90	14	19	17,9	f ₂ +w/2	3	29	90
RIK224.9011.03	90	110	14	19	17,9	f ₂ +w/2	3	29	90
RIK224.1113.03	110	130	14	19	17,9	f ₂ +w/2	3	29	110
RIK224.1318.03	130	180	14	19	17,9	f ₂ +w/2	3	29	130
RIK224.1830.03	180	300	14	19	17,9	f ₂ +w/2	3	29	180
RIK224.3847.04	38	47	14	19	17,4	f ₂ +w/2	4	29	90
RIK224.4760.04	47	60	14	19	17,4	f ₂ +w/2	4	29	90
RIK224.6075.04	60	75	14	19	17,4	f ₂ +w/2	4	29	90
RIK224.7590.04	75	90	14	19	17,4	f ₂ +w/2	4	29	90
RIK224.9013.04	90	130	14	19	17,4	f ₂ +w/2	4	29	90
RIK224.1318.04	130	180	14	19	17,4	f ₂ +w/2	4	29	130
RIK224.3000.04	300	1000	14	19	17,4	f ₂ +w/2	4	29	300

Für Grundhalter R...K1 und L...K2
For basic toolholder R...K1 and L...K2

Weitere Abmessungen auf Anfrage
Further sizes upon request

Abmessungen in mm
Dimensions in mm

Bestellhinweis:

Befestigungsschrauben der Kassetten gehören zum Lieferumfang des Grundhalters.

Ordering note:

The fastening screw is combined with the basic toolholder - no separate order required.

Das Anzugsdrehmoment der Schrauben finden Sie in den Technischen Hinweisen.

For torque specification of the screw, please see Technical Instructions.

Ersatzteile

Spare Parts

Kassette Cassette	Spannschraube Screw	TORX PLUS®-Schlüssel TORX PLUS® Wrench
RIK224...	5.13 T20P	T20PQ

Axialeinstechen

Face Grooving



Kassette

Cassette

RIK224

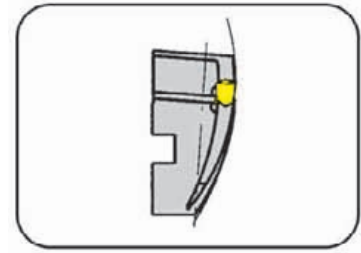

Nutaußen-Ø	Nutaußen-Ø	38 - 1000 mm
Stechtiefe bis	Depth of groove up to	14 mm
Stechbreite	Width of groove	5 - 6 mm

für Wendeschneidplatte
for Indexable insert

Typ S224
Type

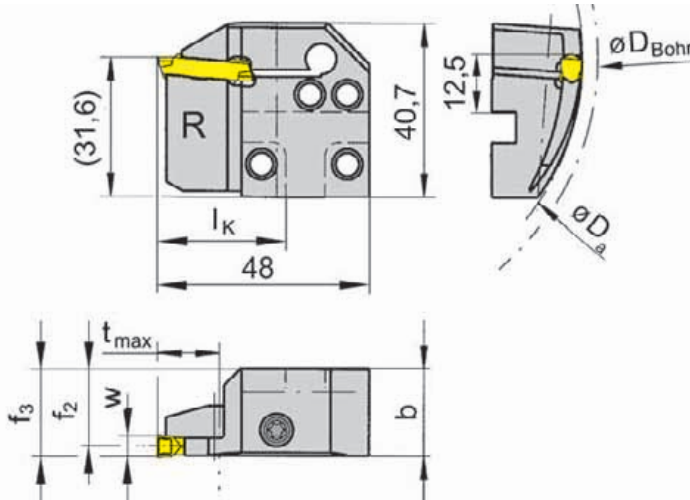

R = Rechtsausführung
R = right hand version

Bestellnummer Part number	D _{a min}	D _{a min2}	t _{max}	b	f ₂	f ₃	w	l _k	D _{Bohr}
RIK224.3847.05	38	47	14	19	16,9	f ₂ +w/2	5	29	90
RIK224.4760.05	47	60	14	19	16,9	f ₂ +w/2	5	29	90
RIK224.6075.05	60	75	14	19	16,9	f ₂ +w/2	5	29	90
RIK224.7590.05	75	90	14	19	16,9	f ₂ +w/2	5	29	90
RIK224.9013.05	90	130	14	19	16,9	f ₂ +w/2	5	29	90
RIK224.1318.05	130	180	14	19	16,9	f ₂ +w/2	5	29	130
RIK224.1830.05	180	300	14	19	16,9	f ₂ +w/2	5	29	180
RIK224.3000.05	300	1000	14	19	16,9	f ₂ +w/2	5	29	300
RIK224.6075.06	60	75	14	19	16,4	f ₂ +w/2	6	29	90
RIK224.7590.06	75	90	14	19	16,4	f ₂ +w/2	6	29	90
RIK224.9013.06	90	130	14	19	16,4	f ₂ +w/2	6	29	90
RIK224.1318.06	130	180	14	19	16,4	f ₂ +w/2	6	29	130
RIK224.1830.06	180	300	14	19	16,4	f ₂ +w/2	6	29	180
RIK224.3000.06	300	1000	14	19	16,4	f ₂ +w/2	6	29	300

Für Grundhalter R...K1 und L...K2
For basic toolholder R...K1 and L...K2

Weitere Abmessungen auf Anfrage
Further sizes upon request

Abmessungen in mm
Dimensions in mm

Bestellhinweis:

Befestigungsschrauben der Kassetten gehören zum Lieferumfang des Grundhalters.

Ordering note:

The fastening screw is combined with the basic toolholder - no separate order required.

Das Anzugsdrehmoment der Schrauben finden Sie in den Technischen Hinweisen.

For torque specification of the screw, please see Technical Instructions.

Ersatzteile

Spare Parts

Kassette Cassette	Spannschraube Screw	TORX PLUS®-Schlüssel TORX PLUS® Wrench
RIK224...	5.13 T20P	T20PQ

Axialeinstechen

Face Grooving



Wendeschneidplatte

Indexable insert

S224

mit Spanformung
with chip forming

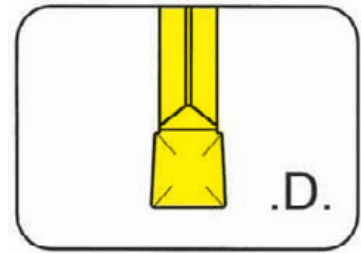

Stechtiefe bis Stechbreite	Depth of groove up to Width of groove	18 mm 3-4 mm
-------------------------------	--	-----------------

D2 präzisionsgesintert / D2.G präzisionsgeschliffen
D2 precision sintered / D2.G precision ground

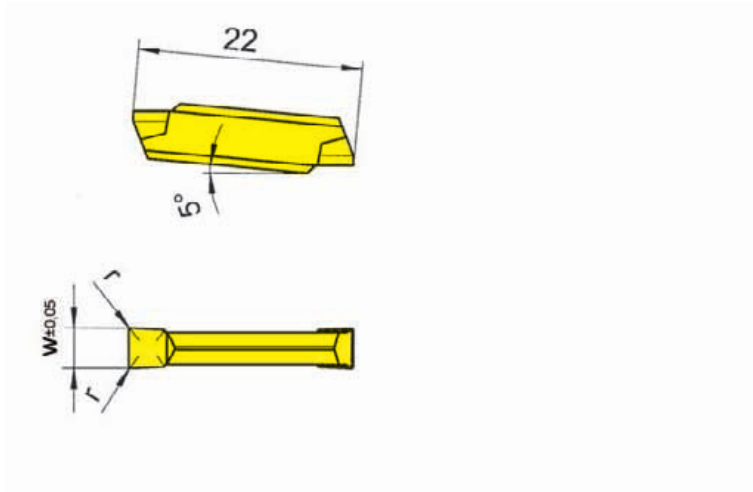

für Kassette
for Cassette

Typ R/LAK224
Type R/LIK224

Wechselgenauigkeit
Länge ± 0,06 mm
Indexability length ± 0,06 mm

Bestellnummer Part number	w	r	Größe Size	H54	TF45	TF46	TI22	TI25	TN32	TN35
S224.0300.D2.G	3	0,2	03		▲	▲	▲			
S224.0300.D2	3	0,2	03	▲	▲	▲		▲	▲	▲
S224.0400.D2.G	4	0,2	04			▲	▲			
S224.0400.D2	4	0,2	04	△	▲	▲		▲	▲	▲
▲ ab Lager / on stock △ 4 Wochen / 4 weeks x auf Anfrage / upon request				P	●	●	●	●	●	●
● empfohlen / recommended				M	●	●	○	-	-	●
○ bedingt einsetzbar / alternative recommendation				K	-	●	●	-	-	●
- nicht geeignet / not suitable				N	-	●	●	-	-	●
■ unbeschichtete HM-Sorten / uncoated grades				S	-	●	○	-	-	●
■ beschichtete HM-Sorten / coated grades				H	-	-	-	-	-	-
■ bestückt/Cermet / brazed/Cermet				HM-Sorten Carbide grades						

Abmessungen in mm
Dimensions in mm

Wendeschneidplatten sind in rechten und linken Kassetten L/RAK224 und L/RIK224 verwendbar.
Indexable inserts can be used in right and left hand cassettes L/RAK224 and L/RIK224.



Axialeinstechen

Face Grooving



Wendeschneidplatte

Indexable insert

S224

mit Spanformung
with chip forming

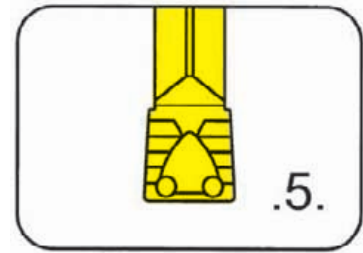

Stechtiefe bis Stechbreite	Depth of groove up to Width of groove	18 mm 3-5 mm
-------------------------------	--	-----------------

präzisionsgesintert
precision sintered

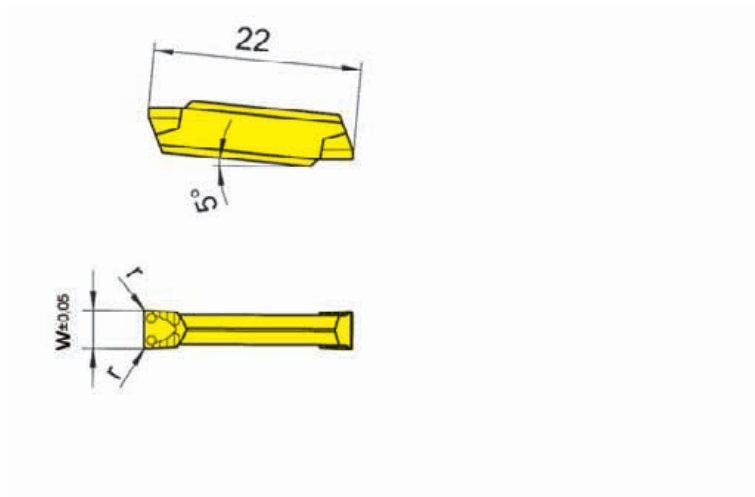

für Kassette
for Cassette

Typ R/LAK224
Type R/LIK224

Wechselgenauigkeit
Länge ± 0,06 mm
Indexability length ± 0,06 mm

Bestellnummer Part number	w	r	Größe Size	AL96	AS62	AS66	EG56	H54	TC92	TF45	TI25	TN32	TN35
S224.0300.52	3	0,2	03	▲	▲	▲	▲	▲	▲	▲	▲	▲	▲
S224.0300.54	3	0,4	03	▲	▲	▲	▲	▲	▲	▲	▲	▲	▲
S224.0400.52	4	0,2	04	▲	▲	▲	▲	▲	▲	▲	▲	▲	▲
S224.0400.54	4	0,4	04	▲	▲	▲	▲	▲	▲	▲	▲	▲	▲
S224.0500.54	5	0,4	05	▲	▲	▲	▲	▲	▲	▲	▲	▲	▲
S224.0500.58	5	0,8	05	▲	▲	▲	▲	▲	▲	▲	▲	▲	▲
▲ ab Lager / on stock Δ 4 Wochen / 4 weeks x auf Anfrage / upon request				P	•	•	•	•	•	•	•	•	•
● empfohlen / recommended				M	-	-	o	o	•	-	•	-	•
o bedingt einsetzbar / alternative recommendation				K	•	-	•	o	-	-	•	-	•
- nicht geeignet / not suitable				N	•	-	•	-	-	-	•	-	•
■ unbeschichtete HM-Sorten / uncoated grades				S	-	-	o	-	-	-	•	-	•
■ beschichtete HM-Sorten / coated grades				H	-	-	-	-	-	-	-	-	-
■ bestückt/Cermet / brazed/Cermet													

Abmessungen in mm
Dimensions in mm

HM-Sorten
Carbide grades

Wendeschneidplatten sind in rechten und linken Kassetten L/RAK224 und L/RIK224 verwendbar.
Indexable inserts can be used in right and left hand cassettes L/RAK224 and L/RIK224.

Axialeinstechen

Face Grooving



Wendeschneidplatte

Indexable insert

S224

mit Spanformung
with chip forming

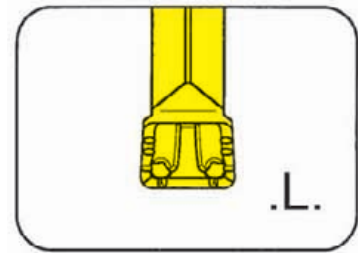

Stechtiefe bis Stechbreite	Depth of groove up to Width of groove	18 mm 4-6 mm
-------------------------------	--	-----------------

präzisionsgesintert
precision sintered

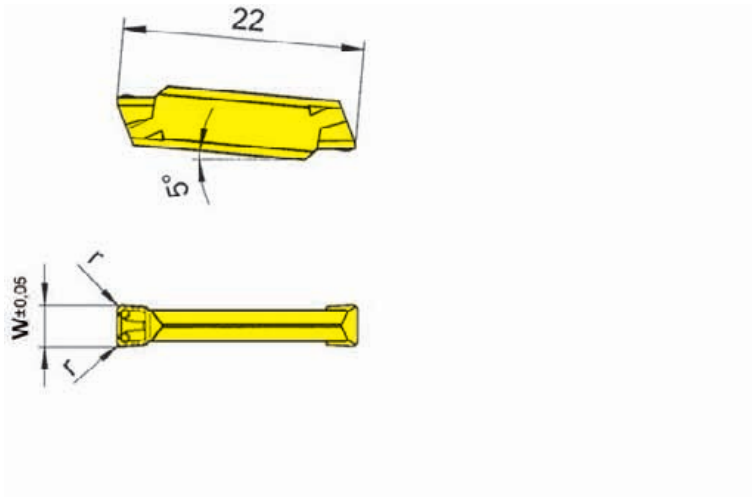

für Kassette
for Cassette

Typ R/LAK224
Type R/LIK224

Wechselgenauigkeit
Länge ± 0,06 mm
Indexability length ± 0,06 mm

Bestellnummer Part number	w	r	Größe Size	AL96	AS62	AS66	ASG6	TF42	Ti22
				S224.0400.L4	4	0,4	04	▲	▲
S224.0500.L4	5	0,4	05	▲	▲	△	△	▲	
S224.0500.L6	5	0,6	05	△	▲	▲	△	▲	
S224.0600.L4	6	0,4	06	▲	▲	▲	▲	▲	
S224.0600.L6	6	0,6	06	▲	▲	▲	△	▲	
▲ ab Lager / on stock △ 4 Wochen / 4 weeks x auf Anfrage / upon request				P	●	●	●	●	●
● empfohlen / recommended				M	-	-	○	○	-
○ bedingt einsetzbar / alternative recommendation				K	●	-	●	○	-
- nicht geeignet / not suitable				N	●	-	●	-	-
■ unbeschichtete HM-Sorten / uncoated grades				S	-	-	○	-	-
■ beschichtete HM-Sorten / coated grades				H	-	-	-	-	-
■ bestückt/Cermet / brazed/Cermet									

Abmessungen in mm
Dimensions in mm

Wendeschneidplatten sind in rechten und linken Kassetten L/RAK224 und L/RIK224 verwendbar.
Indexable inserts can be used in right and left hand cassettes L/RAK224 and L/RIK224.

HM-Sorten
Carbide grades



Axialeinstechen

Face Grooving

Klemmhalter
Toolholder
A226/A210

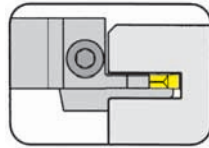

Seite/Page
S64-S67

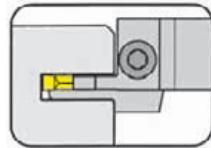

Seite/Page
S65,S67

Kassette
Cassette
LIK220/RIK220/
LAK220/RAK220

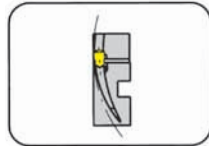

Seite/Page
S68-S83

Wendeschnidplatte
Indexable insert
S229

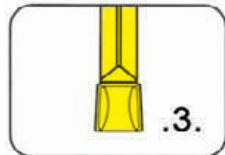

Seite/Page
S84

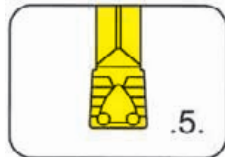

Seite/Page
S85

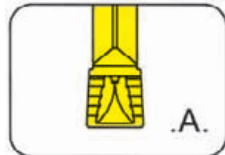

Seite/Page
S86

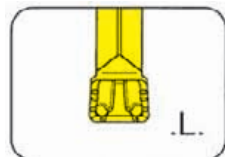

Seite/Page
S87

Schnidplatte
Insert
229

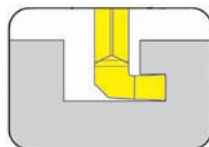

Seite/Page
S88

S

229



S

**Klemmhalter mit
Schneidplatten**

Stechbreite 3 - 6 mm

**Toolholder with
Inserts**

Width of groove 3 - 6 mm

Axialeinstechen

Face Grooving



Klemmhalter

Toolholder

LA226

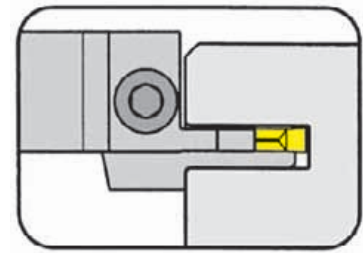

Nutaußen-Ø ab	from outer groove Ø	95 mm
Stechtiefe bis	Depth of groove up to	25 mm
Stechbreite	Width of groove	4 - 5 mm

für Wendeschneidplatte
für Indexable insert

Typ S229
Type

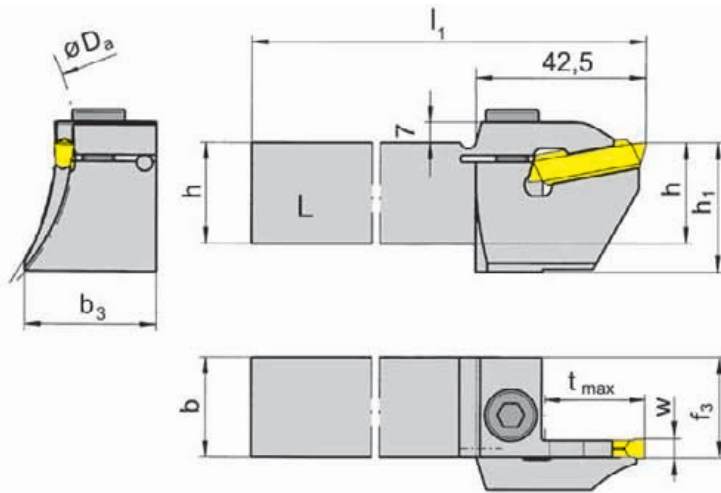

L = Linksausführung
L = left hand version

Bestellnummer Part number	h	b	l_1	h_1	f_3	t_{max}	$D_{a \min}$	$D_{a \min 2}$	b_3	Größe Size
LA226.20.1318.04	20	20	150	32	20,5	25	130	180	25	04
LA226.20.9513.04	20	20	150	32	20,5	25	95	130	26	04
LA226.25.1318.04	25	25	150	32	25,5	25	130	180	30	04
LA226.25.9513.04	25	25	150	32	25,5	25	95	130	31	04
LA226.20.1318.05	20	20	150	32	20,5	25	130	180	25	05
LA226.20.9513.05	20	20	150	32	20,5	25	95	130	28	05
LA226.25.1318.05	25	25	150	32	25,5	25	130	180	30	05
LA226.25.9513.05	25	25	150	32	25,5	25	95	130	33	05

Weitere Abmessungen auf Anfrage
Further sizes upon request

Abmessungen in mm
Dimensions in mm

Das Anzugsdrehmoment der Schrauben finden Sie in den Technischen Hinweisen.
For torque specification of the screw, please see Technical Instructions.

Ersatzteile

Spare Parts

Klemmhalter Toolholder	Spannschraube Screw	Inbus-Schlüssel Wrench
LA226...	218.3	SW6,0 DIN911

Axialeinstechen

Face Grooving



Klemmhalter

Toolholder

RA226

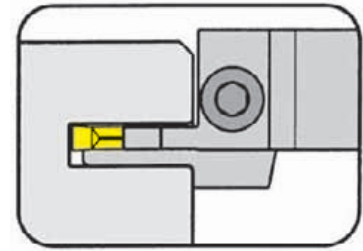

Nutaußen-Ø ab	from outer groove Ø	95 mm
Stechtiefe bis	Depth of groove up to	25 mm
Stechbreite	Width of groove	4 - 5 mm

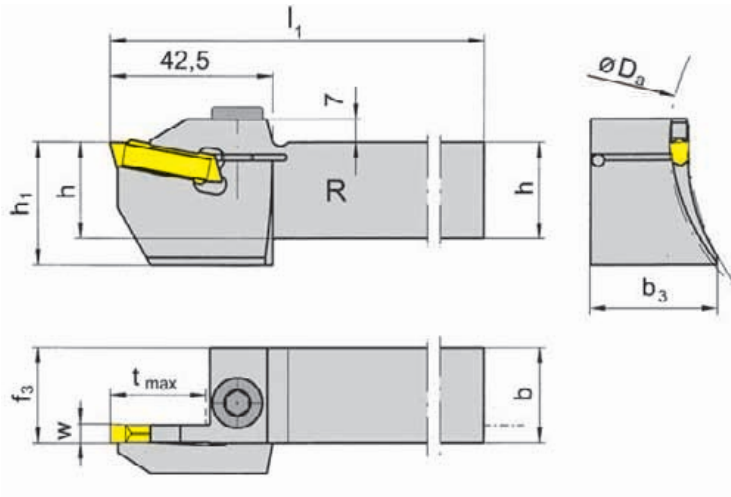

für Wendeschneidplatte
für Indexable insert

Typ S229
Type



R = Rechtsausführung
R = right hand version

Bestellnummer Part number	h	b	l ₁	h ₁	f ₃	t _{max}	D _{a min}	D _{a min2}	b ₃	Größe Size
RA226.20.1318.04	20	20	150	32	20,5	25	130	180	25	04
RA226.20.9513.04	20	20	150	32	20,5	25	95	130	26	04
RA226.25.1318.04	25	25	150	32	25,5	25	130	180	30	04
RA226.25.9513.04	25	25	150	32	25,5	25	95	130	31	04
RA226.20.1318.05	20	20	150	32	20,5	25	130	180	25	05
RA226.20.9513.05	20	20	150	32	20,5	25	95	130	28	05
RA226.25.1318.05	25	25	150	32	25,5	25	130	180	30	05
RA226.25.9513.05	25	25	150	32	25,5	25	95	130	33	05

Weitere Abmessungen auf Anfrage
Further sizes upon request

Abmessungen in mm
Dimensions in mm

Das Anzugsdrehmoment der Schrauben finden Sie in den Technischen Hinweisen.
For torque specification of the screw, please see Technical Instructions.

Ersatzteile

Spare Parts

Klemmhalter Toolholder	Spannschraube Screw	Inbus-Schlüssel Wrench
RA226...	218.3	SW6,0 DIN911

Axialeinstechen

Face Grooving



Klemmhalter

Toolholder

LA210

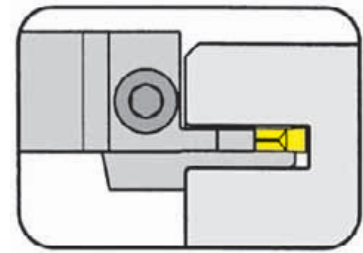

Nutaußen-Ø ab	from outer groove Ø	95 mm
Stechtiefe bis	Depth of groove up to	15 mm
Stechbreite	Width of groove	4 - 5 mm

für Wendeschneidplatte
für Indexable insert

Typ S229
Type

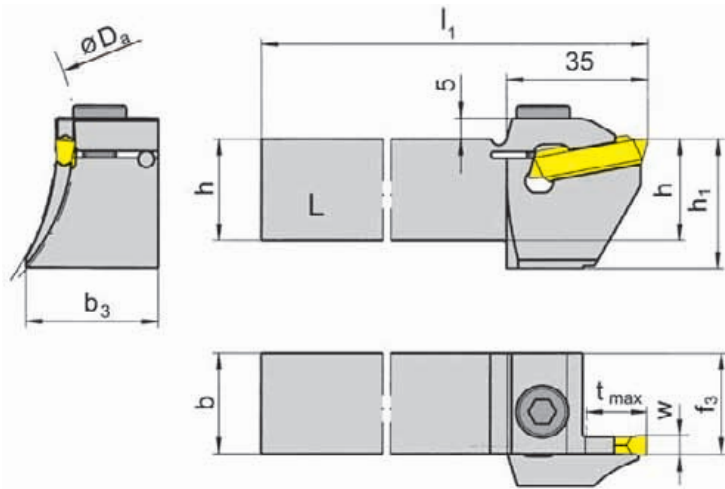

L = Linksausführung
L = left hand version

Bestellnummer Part number	h	b	l_1	h_1	b_3	f_3	t_{max}	$D_{a\ min}$	$D_{a\ max}$	w	Größe Size
LA210.20.1318.14	20	20	150	32	25,0	20,5	15	130	180	4	04
LA210.20.9513.14	20	20	150	32	26,0	20,5	15	95	130	4	04
LA210.25.1318.14	25	25	150	32	30,0	25,5	15	130	180	4	04
LA210.25.9513.14	25	25	150	32	31,0	25,5	15	95	130	4	04
LA210.20.1318.15	20	20	150	32	25,0	20,5	15	130	180	5	05
LA210.20.9513.15	20	20	150	32	28,0	20,5	15	95	130	5	05
LA210.25.1318.15	25	25	150	32	30,0	25,5	15	130	180	5	05
LA210.25.9513.15	25	25	150	32	33,0	25,5	15	95	130	5	05
LA210.25.1318.18	25	25	150	32	30,5	25,5	15	130	180	8	08

Weitere Abmessungen auf Anfrage
Further sizes upon request

Abmessungen in mm
Dimensions in mm

Das Anzugsdrehmoment der Schrauben finden Sie in den Technischen Hinweisen.
For torque specification of the screw, please see Technical Instructions.

Ersatzteile

Spare Parts

Klemmhalter Toolholder	Spannschraube Screw	Inbus-Schlüssel Wrench
LA210...	218.3	SW6,0 DIN911

Axialeinstechen

Face Grooving



Klemmhalter

Toolholder

RA210

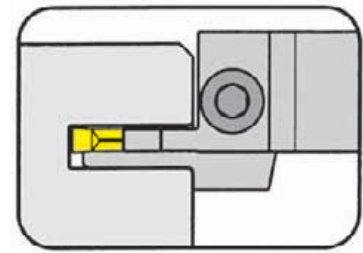

Nutaußen-Ø ab	from outer groove Ø	95 mm
Stechtiefe bis	Depth of groove up to	15 mm
Stechbreite	Width of groove	4 - 5 mm

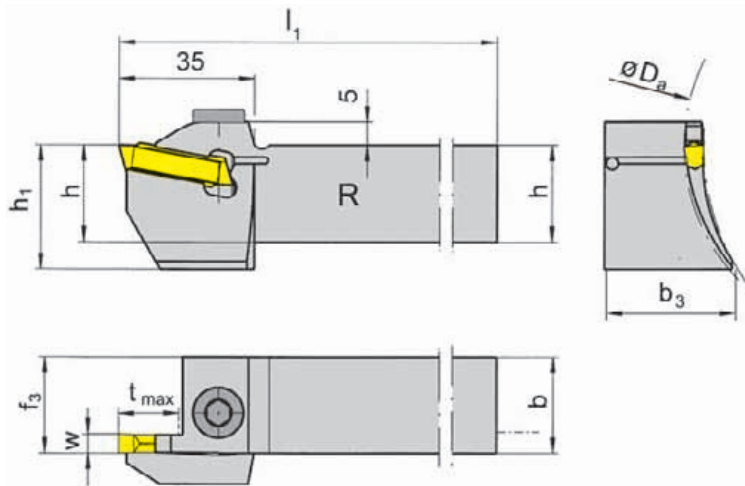

für Wendeschneidplatte
für Indexable insert

Typ S229
Type

R = Rechtsausführung
R = right hand version

Bestellnummer Part number	h	b	l ₁	h ₁	b ₃	f ₃	t _{max}	D _{a min}	D _{a max}	w	Größe Size
RA210.20.1318.14	20	20	150	32	25,0	20,5	15	130	180	4	04
RA210.20.9513.14	20	20	150	32	26,0	20,5	15	95	130	4	04
RA210.25.1318.14	25	25	150	32	30,0	25,5	15	130	180	4	04
RA210.25.9513.14	25	25	150	32	31,0	25,5	15	95	130	4	04
RA210.20.1318.15	20	20	150	32	25,0	20,5	15	130	180	5	05
RA210.25.1318.15	25	25	150	32	30,0	25,5	15	130	180	5	05
RA210.32.1318.15	32	32	150	32	37,0	32,5	15	130	180	5	05
RA210.20.9513.15	20	20	150	32	28,0	20,5	15	95	130	5	05
RA210.25.9513.15	25	25	150	32	33,0	25,5	15	95	130	5	05
RA210.25.1318.18	25	25	150	32	30,5	25,5	15	130	180	8	08

Weitere Abmessungen auf Anfrage
Further sizes upon request

Abmessungen in mm
Dimensions in mm

Das Anzugsdrehmoment der Schrauben finden Sie in den Technischen Hinweisen.
For torque specification of the screw, please see Technical Instructions.

Ersatzteile

Spare Parts

Klemmhalter Toolholder	Spannschraube Screw	Inbus-Schlüssel Wrench
RA210...	218.3	SW6,0 DIN911

Axialeinstechen

Face Grooving



Kassette

Cassette

LIK220

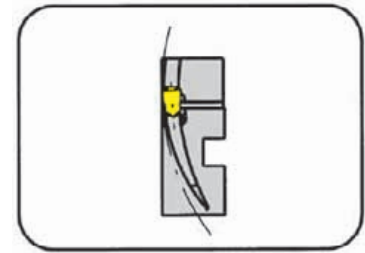

Nutaußen-Ø ab	from outer groove Ø	60 - 300 mm
Stechtiefe bis	Depth of groove up to	15 mm
Stechbreite	Width of groove	4 - 5 mm

für Wendeschneidplatte
für Indexable insert

Typ S229
Type

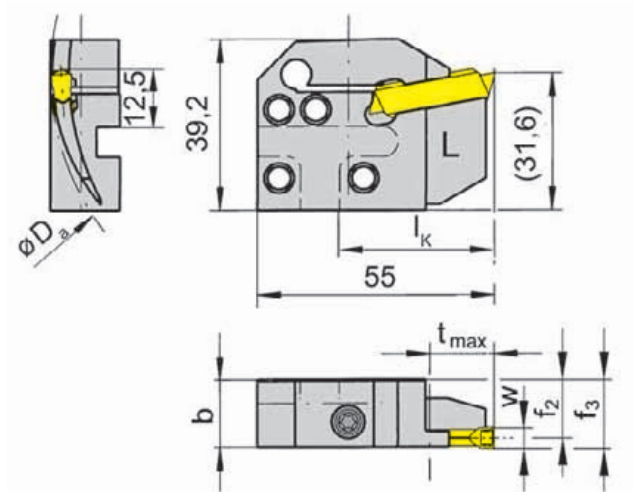

L = Linksausführung
L = left hand version

Bestellnummer Part number	D _{a min}	D _{a min2}	t _{max}	b	f ₂	f ₃	w	l _k
LIK220.6575.14	65	75	10	15,7	14,4	f ₂ +w/2	4	36
LIK220.7595.14	75	95	15	15,7	14,4	f ₂ +w/2	4	36
LIK220.9513.14	95	130	15	15,7	14,4	f ₂ +w/2	4	36
LIK220.1318.14	130	180	15	15,7	14,4	f ₂ +w/2	4	36
LIK220.1830.14	180	300	15	15,7	14,4	f ₂ +w/2	4	36
LIK220.6075.15	60	75	10	15,7	13,9	f ₂ +w/2	5	36
LIK220.7595.15	75	95	15	15,7	13,9	f ₂ +w/2	5	36
LIK220.9513.15	95	130	15	15,7	13,9	f ₂ +w/2	5	36
LIK220.1318.15	130	180	15	15,7	13,9	f ₂ +w/2	5	36
LIK220.1830.15	180	300	15	15,7	13,9	f ₂ +w/2	5	36

Für Grundhalter L...K1 und R...K2

For basic toolholder L...K1 and R...K2

Weitere Abmessungen auf Anfrage

Further sizes upon request

Bestellhinweis:

Befestigungsschrauben der Kassetten gehören zum Lieferumfang des Grundhalters.

Ordering note:

The fastening screw is combined with the basic toolholder - no separate order required.

Das Anzugsdrehmoment der Schrauben finden Sie in den Technischen Hinweisen.

For torque specification of the screw, please see Technical Instructions.

Abmessungen in mm

Dimensions in mm

Ersatzteile

Spare Parts

Kassette Cassette	Spannschraube Screw	TORX PLUS®-Schlüssel TORX PLUS® Wrench
LIK220...	6.23T25P	T25PQ

Axialeinstechen

Face Grooving



Kassette

Cassette

LIK220

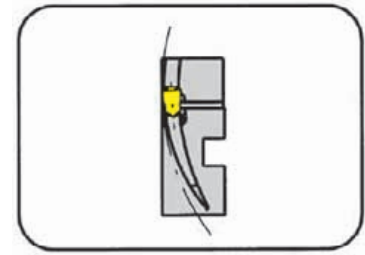

Nutaußen-Ø ab
Stechtiefe bis
Stechbreite

from outer groove Ø
Depth of groove up to
Width of groove

60 - 300 mm
15 mm
6 mm

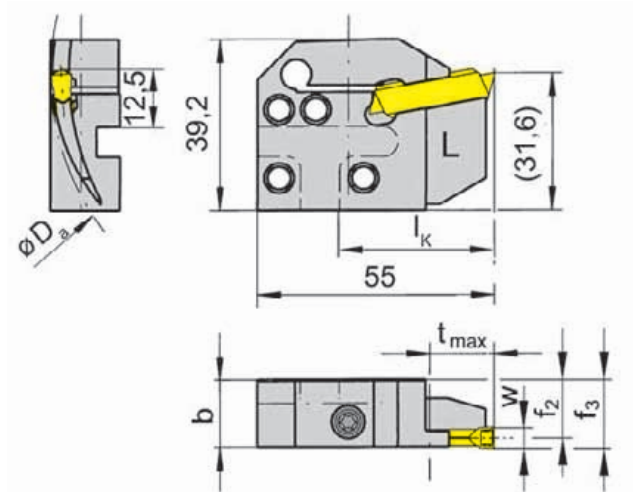

für Wendeschneidplatte
für Indexable insert

Typ S229
Type

L = Linksausführung
L = left hand version

Bestellnummer Part number	D _{a min}	D _{a min2}	t _{max}	b	f ₂	f ₃	w	l _k
LIK220.6075.16	60	75	10	15,7	13,4	f ₂ +w/2	6	36
LIK220.7595.16	75	95	15	15,7	13,4	f ₂ +w/2	6	36
LIK220.9513.16	95	130	15	15,7	13,4	f ₂ +w/2	6	36
LIK220.1318.16	130	180	15	15,7	13,4	f ₂ +w/2	6	36
LIK220.1830.16	180	300	15	15,7	13,4	f ₂ +w/2	6	36

Für Grundhalter L...K1 und R...K2
For basic toolholder L...K1 and R...K2

Abmessungen in mm
Dimensions in mm

Weitere Abmessungen auf Anfrage
Further sizes upon request

Bestellhinweis:

Befestigungsschrauben der Kassetten gehören zum Lieferumfang des Grundhalters.

Ordering note:

The fastening screw is combined with the basic toolholder - no separate order required.

Das Anzugsdrehmoment der Schrauben finden Sie in den Technischen Hinweisen.

For torque specification of the screw, please see Technical Instructions.

Ersatzteile

Spare Parts

Kassette Cassette	Spannschraube Screw	TORX PLUS®-Schlüssel TORX PLUS® Wrench
LIK220...	6.23T25P	T25PQ

Axialeinstechen

Face Grooving



Kassette

Cassette

RIK220

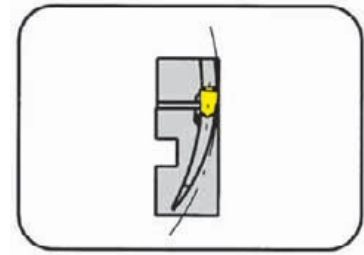

Nutaußen-Ø ab	from outer groove Ø	60 - 300 mm
Stechtiefe bis	Depth of groove up to	15 mm
Stechbreite	Width of groove	4 - 5 mm

für Wendeschneidplatte
für Indexable insert

Typ S229
Type

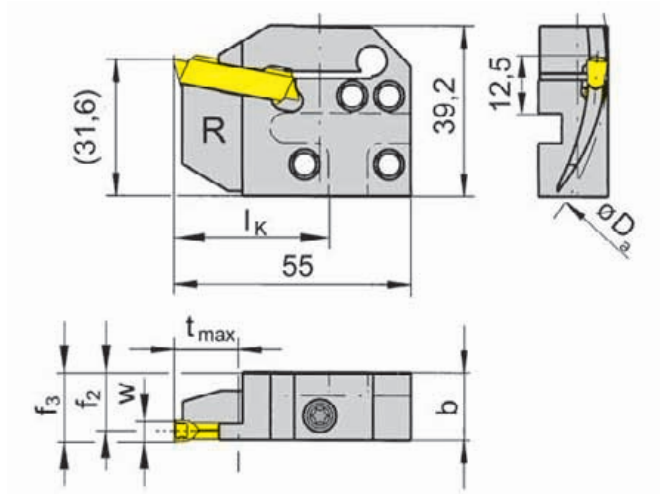

R = Rechtsausführung
R = right hand version

Bestellnummer Part number	$D_{a \min}$	$D_{a \min 2}$	t_{\max}	b	f_2	f_3	w	l_k
RIK220.6575.14	65	75	10	15,7	14,4	$f_2+w/2$	4	36
RIK220.7595.14	75	95	15	15,7	14,4	$f_2+w/2$	4	36
RIK220.9513.14	95	130	15	15,7	14,4	$f_2+w/2$	4	36
RIK220.1318.14	130	180	15	15,7	14,4	$f_2+w/2$	4	36
RIK220.1830.14	180	300	15	15,7	14,4	$f_2+w/2$	4	36
RIK220.6075.15	60	75	10	15,7	13,9	$f_2+w/2$	5	36
RIK220.7595.15	75	95	15	15,7	13,9	$f_2+w/2$	5	36
RIK220.9513.15	95	130	15	15,7	13,9	$f_2+w/2$	5	36
RIK220.1318.15	130	180	15	15,7	13,9	$f_2+w/2$	5	36
RIK220.1830.15	180	300	15	15,7	13,9	$f_2+w/2$	5	36

Für Grundhalter R...K1 und L...K2

For basic toolholder R...K1 and L...K2

Weitere Abmessungen auf Anfrage

Further sizes upon request

Bestellhinweis:

Befestigungsschrauben der Kassetten gehören zum Lieferumfang des Grundhalters.

Ordering note:

The fastening screw is combined with the basic toolholder - no separate order required.

Das Anzugsdrehmoment der Schrauben finden Sie in den Technischen Hinweisen.

For torque specification of the screw, please see Technical Instructions.

Abmessungen in mm

Dimensions in mm

Ersatzteile

Spare Parts

Kassette Cassette	Spannschraube Screw	TORX PLUS®-Schlüssel TORX PLUS® Wrench
RIK220...	6.23T25P	T25PQ

Axialeinstechen

Face Grooving



Kassette

Cassette

RIK220

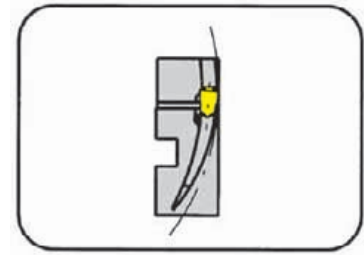

Nutaußen-Ø ab	from outer groove Ø	60 - 300 mm
Stechtiefe bis	Depth of groove up to	15 mm
Stechbreite	Width of groove	6 mm

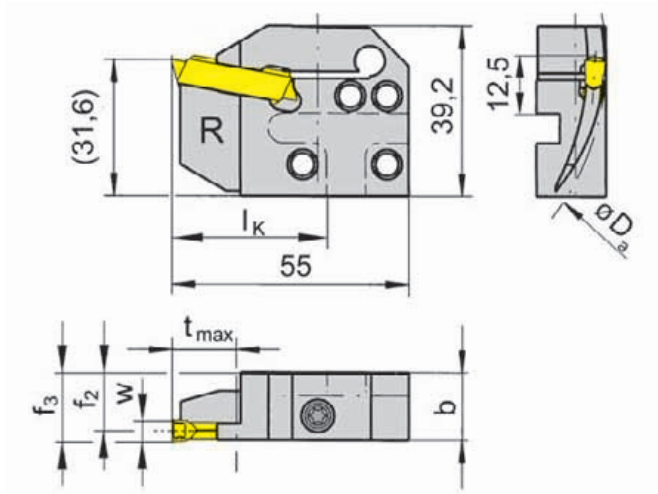

für Wendeschneidplatte
für Indexable insert

Typ S229
Type

R = Rechtsausführung
R = right hand version

Bestellnummer Part number	D _{a min}	D _{a min2}	t _{max}	b	f ₂	f ₃	w	l _k
RIK220.6075.16	60	75	10	15,7	13,4	f ₂ +w/2	6	36
RIK220.7595.16	75	95	15	15,7	13,4	f ₂ +w/2	6	36
RIK220.9513.16	95	130	15	15,7	13,4	f ₂ +w/2	6	36
RIK220.1318.16	130	180	15	15,7	13,4	f ₂ +w/2	6	36
RIK220.1830.16	180	300	15	15,7	13,4	f ₂ +w/2	6	36

Für Grundhalter R...K1 und L...K2
For basic toolholder R...K1 and L...K2

Abmessungen in mm
Dimensions in mm

Weitere Abmessungen auf Anfrage
Further sizes upon request

Bestellhinweis:

Befestigungsschrauben der Kassetten gehören zum Lieferumfang des Grundhalters.

Ordering note:

The fastening screw is combined with the basic toolholder - no separate order required.

Das Anzugsdrehmoment der Schrauben finden Sie in den Technischen Hinweisen.

For torque specification of the screw, please see Technical Instructions.

Ersatzteile

Spare Parts

Kassette Cassette	Spannschraube Screw	TORX PLUS®-Schlüssel TORX PLUS® Wrench
RIK220...	6.23T25P	T25PQ

Axialeinstechen

Face Grooving



Kassette

Cassette

LAK220

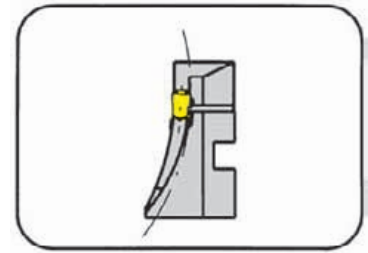

Nutaußen-Ø ab	from outer groove Ø	60 - 300 mm
Stechtiefe bis	Depth of groove up to	15 mm
Stechbreite	Width of groove	4 - 5 mm

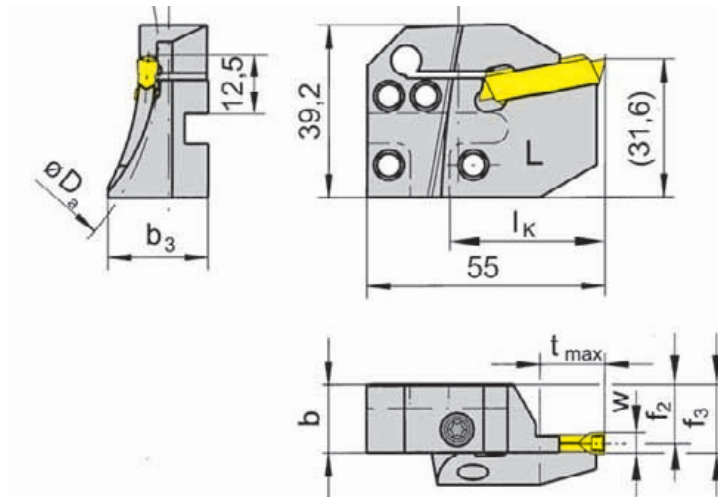

für Wendeschneidplatte
für Indexable insert

Typ S229
Type

L = Linksausführung
L = left hand version

Bestellnummer Part number	D _{a min}	D _{a min2}	t _{max}	b	b ₃	f ₂	f ₃	w	l _k
LAK220.6575.14	65	75	10	15,7	23,0	14,4	f ₂ +w/2	4	36
LAK220.7595.14	75	95	15	15,7	23,0	14,4	f ₂ +w/2	4	36
LAK220.9513.14	95	130	15	15,7	21,2	14,4	f ₂ +w/2	4	36
LAK220.1318.14	130	180	15	15,7	21,2	14,4	f ₂ +w/2	4	36
LAK220.1830.14	180	300	15	15,7	19,0	14,4	f ₂ +w/2	4	36
LAK220.6075.15	60	75	10	15,7	23,0	13,9	f ₂ +w/2	5	36
LAK220.7595.15	75	95	15	15,7	23,0	13,9	f ₂ +w/2	5	36
LAK220.9513.15	95	130	15	15,7	23,0	13,9	f ₂ +w/2	5	36
LAK220.1318.15	130	180	15	15,7	21,2	13,9	f ₂ +w/2	5	36
LAK220.1830.15	180	300	15	15,7	19,0	13,9	f ₂ +w/2	5	36

Für Grundhalter L...K1 und R...K2
For basic toolholder L...K1 and R...K2

Abmessungen in mm
Dimensions in mm

Weitere Abmessungen auf Anfrage
Further sizes upon request

Bestellhinweis:

Befestigungsschrauben der Kassetten gehören zum Lieferumfang des Grundhalters.

Ordering note:

The fastening screw is combined with the basic toolholder - no separate order required.

Das Anzugsdrehmoment der Schrauben finden Sie in den Technischen Hinweisen.

For torque specification of the screw, please see Technical Instructions.

Ersatzteile

Spare Parts

Kassette Cassette	Spannschraube Screw	TORX PLUS®-Schlüssel TORX PLUS® Wrench
LAK220...	6.23T25P	T25PQ

Axialeinstechen

Face Grooving



Kassette

Cassette

LAK220

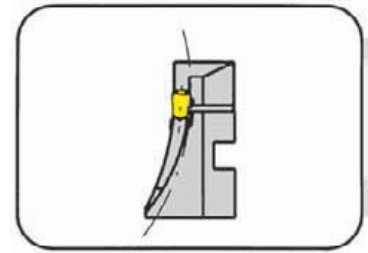

Nutaußen-Ø ab	from outer groove Ø	60 - 300 mm
Stechtiefe bis	Depth of groove up to	15 mm
Stechbreite	Width of groove	6 mm

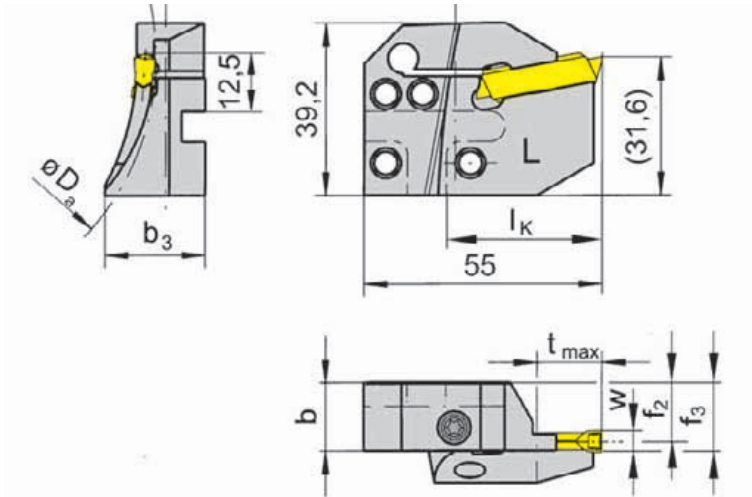

für Wendeschneidplatte
für Indexable insert

Typ S229
Type

L = Linksausführung
L = left hand version

Bestellnummer Part number	D _{a min}	D _{a min2}	t _{max}	b	b ₃	f ₂	f ₃	w	l _k
LAK220.6075.16	60	75	10	15,7	23,0	13,4	f ₂ +w/2	6	36
LAK220.7595.16	75	95	15	15,7	23,0	13,4	f ₂ +w/2	6	36
LAK220.9513.16	95	130	15	15,7	23,0	13,4	f ₂ +w/2	6	36
LAK220.1318.16	130	180	15	15,7	21,2	13,4	f ₂ +w/2	6	36
LAK220.1830.16	180	300	15	15,7	19,0	13,4	f ₂ +w/2	6	36

Für Grundhalter L...K1 und R...K2
For basic toolholder L...K1 and R...K2

Abmessungen in mm
Dimensions in mm

Weitere Abmessungen auf Anfrage
Further sizes upon request

Bestellhinweis:

Befestigungsschrauben der Kassetten gehören zum Lieferumfang des Grundhalters.

Ordering note:

The fastening screw is combined with the basic toolholder - no separate order required.

Das Anzugsdrehmoment der Schrauben finden Sie in den Technischen Hinweisen.

For torque specification of the screw, please see Technical Instructions.

Ersatzteile

Spare Parts

Kassette Cassette	Spannschraube Screw	TORX PLUS®-Schlüssel TORX PLUS® Wrench
LAK220...	6.23T25P	T25PQ

Axialeinstechen

Face Grooving



Kassette

Cassette

RAK220

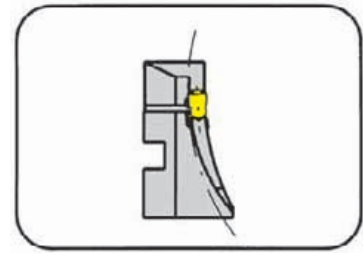

Nutaußen-Ø ab	from outer groove Ø	60 - 300 mm
Stechtiefe bis	Depth of groove up to	15 mm
Stechbreite	Width of groove	4 - 5 mm

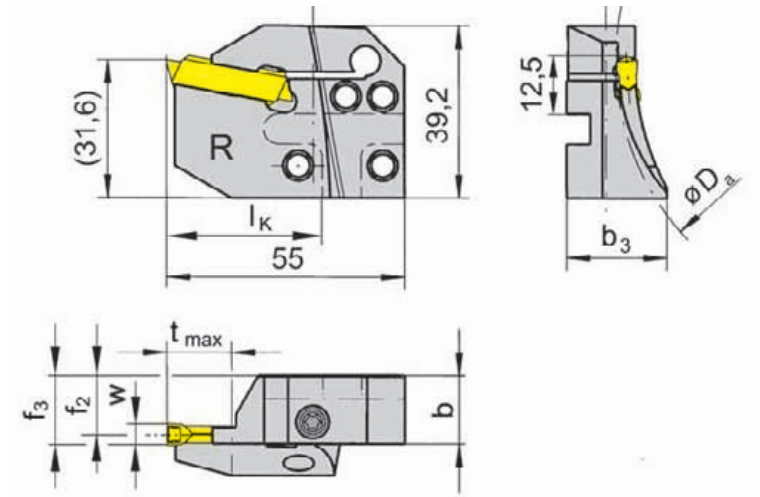

für Wendeschneidplatte
für Indexable insert

Typ S229
Type

R = Rechtsausführung
R = right hand version

Bestellnummer Part number	D _{a min}	D _{a min2}	t _{max}	b	b ₃	f ₂	f ₃	w	l _k
RAK220.6575.14	65	75	10	15,7	23,0	14,4	f ₂ +w/2	4	36
RAK220.7595.14	75	95	15	15,7	23,0	14,4	f ₂ +w/2	4	36
RAK220.9513.14	95	130	15	15,7	21,2	14,4	f ₂ +w/2	4	36
RAK220.1318.14	130	180	15	15,7	21,2	14,4	f ₂ +w/2	4	36
RAK220.1830.14	180	300	15	15,7	19,0	14,4	f ₂ +w/2	4	36
RAK220.6075.15	60	75	10	15,7	23,0	13,9	f ₂ +w/2	5	36
RAK220.7595.15	75	95	15	15,7	23,0	13,9	f ₂ +w/2	5	36
RAK220.9513.15	95	130	15	15,7	23,0	13,9	f ₂ +w/2	5	36
RAK220.1318.15	130	180	15	15,7	21,2	13,9	f ₂ +w/2	5	36
RAK220.1830.15	180	300	15	15,7	19,0	13,9	f ₂ +w/2	5	36

Für Grundhalter R...K1 und L...K2
For basic toolholder R...K1 and L...K2

Abmessungen in mm
Dimensions in mm

Weitere Abmessungen auf Anfrage
Further sizes upon request

Bestellhinweis:

Befestigungsschrauben der Kassetten gehören zum Lieferumfang des Grundhalters.

Ordering note:

The fastening screw is combined with the basic toolholder - no separate order required.

Das Anzugsdrehmoment der Schrauben finden Sie in den Technischen Hinweisen.

For torque specification of the screw, please see Technical Instructions.

Ersatzteile

Spare Parts

Kassette Cassette	Spannschraube Screw	TORX PLUS®-Schlüssel TORX PLUS® Wrench
RAK220...	6.23T25P	T25PQ

Axialeinstechen

Face Grooving



Kassette

Cassette

RAK220

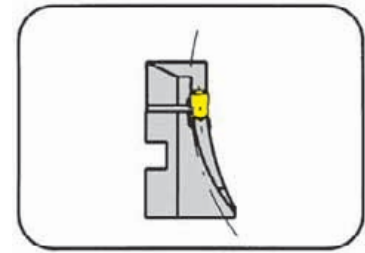

Nutaußen-Ø ab	from outer groove Ø	60 - 300 mm
Stechtiefe bis	Depth of groove up to	15 mm
Stechbreite	Width of groove	6 mm

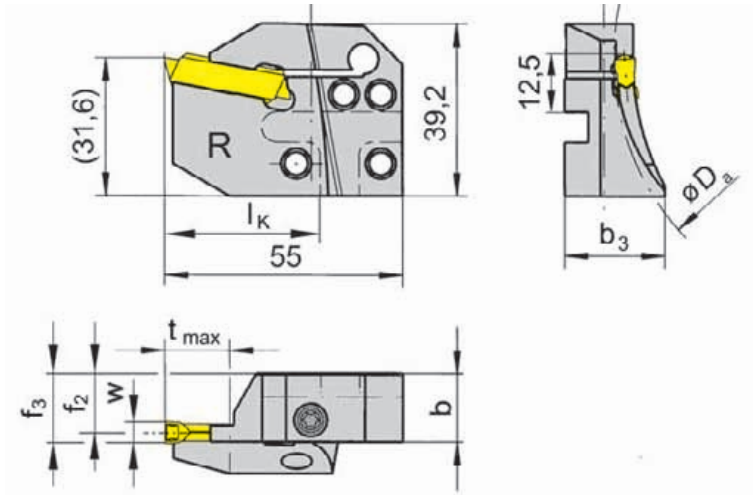

für Wendeschneidplatte
für Indexable insert

Typ S229
Type

R = Rechtsausführung
R = right hand version

Bestellnummer Part number	$D_{a \min}$	$D_{a \min 2}$	t_{\max}	b	b_3	f_2	f_3	w	l_k
RAK220.6075.16	60	75	10	15,7	23,0	13,4	$f_2+w/2$	6	36
RAK220.7595.16	75	95	15	15,7	23,0	13,4	$f_2+w/2$	6	36
RAK220.9513.16	95	130	15	15,7	23,0	13,4	$f_2+w/2$	6	36
RAK220.1318.16	130	180	15	15,7	21,2	13,4	$f_2+w/2$	6	36
RAK220.1830.16	180	300	15	15,7	19,0	13,4	$f_2+w/2$	6	36

Für Grundhalter R...K1 und L...K2
For basic toolholder R...K1 and L...K2

Abmessungen in mm
Dimensions in mm

Weitere Abmessungen auf Anfrage
Further sizes upon request

Bestellhinweis:

Befestigungsschrauben der Kassetten gehören zum Lieferumfang des Grundhalters.

Ordering note:

The fastening screw is combined with the basic toolholder - no separate order required.

Das Anzugsdrehmoment der Schrauben finden Sie in den Technischen Hinweisen.

For torque specification of the screw, please see Technical Instructions.

Ersatzteile

Spare Parts

Kassette Cassette	Spannschraube Screw	TORX PLUS®-Schlüssel TORX PLUS® Wrench
RAK220...	6.23T25P	T25PQ

Axialeinstechen

Face Grooving



Kassette

Cassette

LIK220

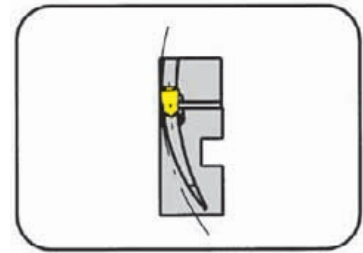

Nutaußen-Ø ab
Stechtiefe bis
Stechbreite

from outer groove Ø
Depth of groove up to
Width of groove

60 - 1000 mm
25 mm
4 - 5 mm

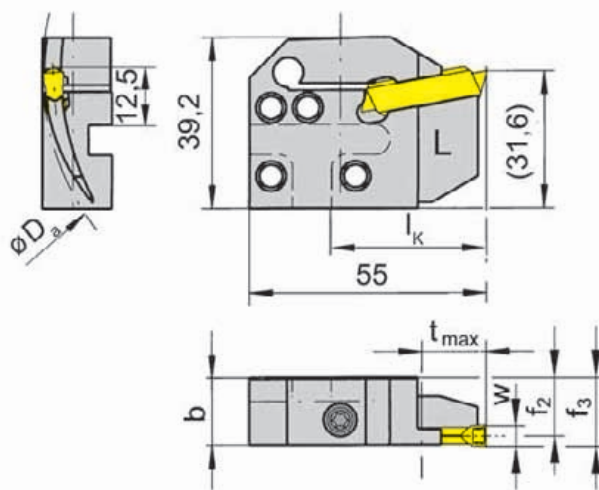

für Wendeschneidplatte
für Indexable insert

Typ S229
Type

L = Linksausführung
L = left hand version

Bestellnummer Part number	D _{a min}	D _{a max}	t _{max}	b	f ₂	f ₃	w	l _k
LIK220.6575.04	65	75	10-15	15,7	14,4	f ₂ +w/2	4	36
LIK220.7595.04	75	95	15-25	15,7	14,4	f ₂ +w/2	4	36
LIK220.9513.04	95	130	25	15,7	14,4	f ₂ +w/2	4	36
LIK220.1318.04	130	180	25	15,7	14,4	f ₂ +w/2	4	36
LIK220.1830.04	180	300	25	15,7	14,4	f ₂ +w/2	4	36
LIK220.3000.04	300	1000	25	15,7	14,4	f ₂ +w/2	4	36
LIK220.6075.05	60	75	10-17	15,7	13,9	f ₂ +w/2	5	36
LIK220.7595.05	75	95	17-25	15,7	13,9	f ₂ +w/2	5	36
LIK220.9513.05	95	130	25	15,7	13,9	f ₂ +w/2	5	36
LIK220.1318.05	130	180	25	15,7	13,9	f ₂ +w/2	5	36
LIK220.1830.05	180	300	25	15,7	13,9	f ₂ +w/2	5	36
LIK220.3000.05	300	1000	25	15,7	13,9	f ₂ +w/2	5	36

Für Grundhalter L...K1 und R...K2
For basic toolholder L...K1 and R...K2

Weitere Abmessungen auf Anfrage
Further sizes upon request

Abmessungen in mm
Dimensions in mm

Bestellhinweis:

Befestigungsschrauben der Kassetten gehören zum Lieferumfang des Grundhalters.

Ordering note:

The fastening screw is combined with the basic toolholder - no separate order required.

Das Anzugsdrehmoment der Schrauben finden Sie in den Technischen Hinweisen.

For torque specification of the screw, please see Technical Instructions.

Ersatzteile

Spare Parts

Kassette Cassette	Spannschraube Screw	TORX PLUS®-Schlüssel TORX PLUS® Wrench
LIK220...	6.23T25P	T25PQ

Axialeinstechen

Face Grooving



Kassette

Cassette

LIK220

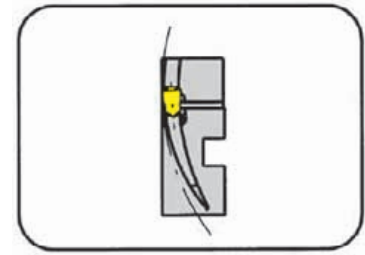

Nutaußen-Ø ab	from outer groove Ø	60 - 1000 mm
Stechtiefe bis	Depth of groove up to	25 mm
Stechbreite	Width of groove	6 mm

für Wendeschneidplatte
für Indexable insert

Typ S229
Type

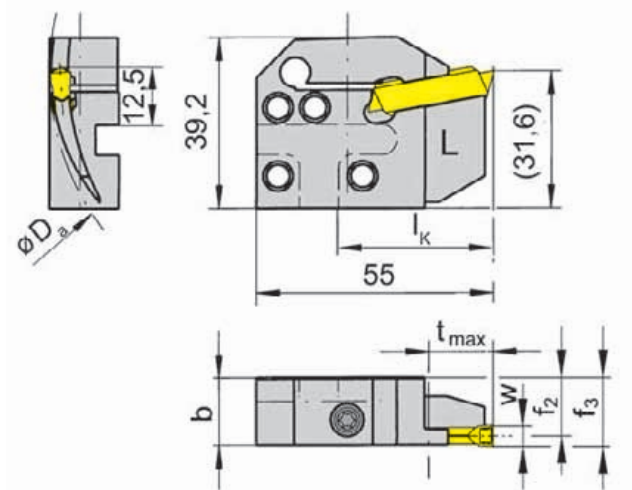

L = Linksausführung
L = left hand version

Bestellnummer Part number	D _{a min}	D _{a max}	t _{max}	b	f ₂	f ₃	w	l _k
LIK220.6075.06	60	75	10-17	15,7	13,4	f ₂ +w/2	6	36
LIK220.7595.06	75	95	17-25	15,7	13,4	f ₂ +w/2	6	36
LIK220.9513.06	95	130	25	15,7	13,4	f ₂ +w/2	6	36
LIK220.1318.06	130	180	25	15,7	13,4	f ₂ +w/2	6	36
LIK220.1830.06	180	300	25	15,7	13,4	f ₂ +w/2	6	36
LIK220.3000.06	300	1000	25	15,7	13,4	f ₂ +w/2	6	36

Für Grundhalter L...K1 und R...K2
For basic toolholder L...K1 and R...K2

Abmessungen in mm
Dimensions in mm

Weitere Abmessungen auf Anfrage
Further sizes upon request

Bestellhinweis:

Befestigungsschrauben der Kassetten gehören zum Lieferumfang des Grundhalters.

Ordering note:

The fastening screw is combined with the basic toolholder - no separate order required.

Das Anzugsdrehmoment der Schrauben finden Sie in den Technischen Hinweisen.

For torque specification of the screw, please see Technical Instructions.

Ersatzteile

Spare Parts

Kassette Cassette	Spannschraube Screw	TORX PLUS®-Schlüssel TORX PLUS® Wrench
LIK220...	6.23T25P	T25PQ

Axialeinstechen

Face Grooving



Kassette

Cassette

RIK220

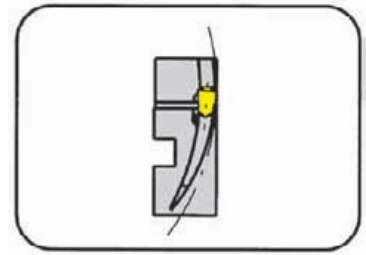

Nutaußen-Ø ab	from outer groove Ø	60 - 1000 mm
Stechtiefe bis	Depth of groove up to	25 mm
Stechbreite	Width of groove	4 - 5 mm

für Wendeschneidplatte
für Indexable insert

Typ S229
Type

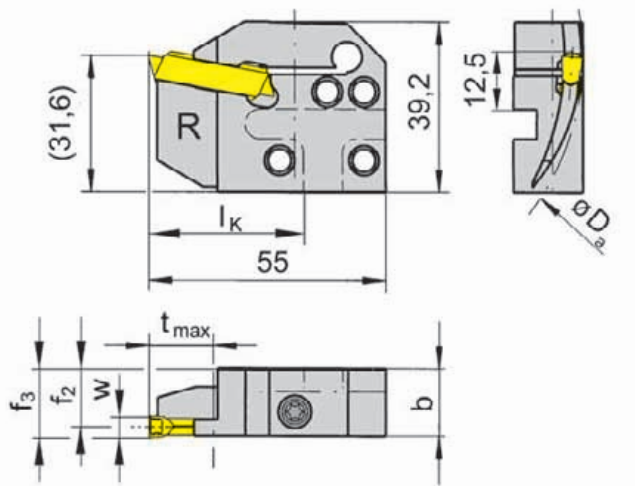

R = Rechtsausführung
R = right hand version

Bestellnummer Part number	D _{a min}	D _{a max}	t _{max}	b	f ₂	f ₃	w	I _k
RIK220.6575.04	65	75	10-15	15,7	14,4	f ₂ +w/2	4	36
RIK220.7595.04	75	95	15-25	15,7	14,4	f ₂ +w/2	4	36
RIK220.9513.04	95	130	25	15,7	14,4	f ₂ +w/2	4	36
RIK220.1318.04	130	180	25	15,7	14,4	f ₂ +w/2	4	36
RIK220.1830.04	180	300	25	15,7	14,4	f ₂ +w/2	4	36
RIK220.3000.04	300	1000	25	15,7	14,4	f ₂ +w/2	4	36
RIK220.6075.05	60	75	10	15,7	13,9	f ₂ +w/2	5	36
RIK220.7595.05	75	95	17	15,7	13,9	f ₂ +w/2	5	36
RIK220.9513.05	95	130	25	15,7	13,9	f ₂ +w/2	5	36
RIK220.1318.05	130	180	25	15,7	13,9	f ₂ +w/2	5	36
RIK220.1830.05	180	300	25	15,7	13,9	f ₂ +w/2	5	36
RIK220.3000.05	300	1000	25	15,7	13,9	f ₂ +w/2	5	36

Für Grundhalter R...K1 und L...K2
For basic toolholder R...K1 and L...K2

Weitere Abmessungen auf Anfrage
Further sizes upon request

Abmessungen in mm
Dimensions in mm

Bestellhinweis:

Befestigungsschrauben der Kassetten gehören zum Lieferumfang des Grundhalters.

Ordering note:

The fastening screw is combined with the basic toolholder - no separate order required.

Das Anzugsdrehmoment der Schrauben finden Sie in den Technischen Hinweisen.

For torque specification of the screw, please see Technical Instructions.

Ersatzteile

Spare Parts

Kassette Cassette	Spannschraube Screw	TORX PLUS®-Schlüssel TORX PLUS® Wrench
RIK220...	6.23T25P	T25PQ

Axialeinstechen

Face Grooving



Kassette

Cassette

RIK220

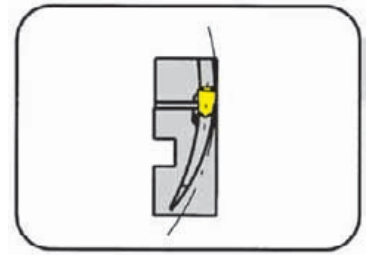

Nutaußen-Ø ab
Stechtiefe bis
Stechbreite

from outer groove Ø
Depth of groove up to
Width of groove

60 - 1000 mm
25 mm
6 mm

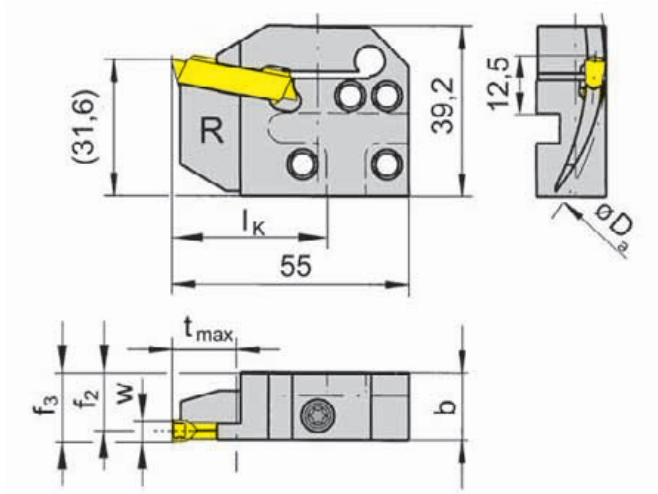

für Wendeschneidplatte
für Indexable insert

Typ S229
Type



R = Rechtsausführung
R = right hand version

Bestellnummer Part number	$D_{a \min}$	$D_{a \max}$	t_{\max}	b	f_2	f_3	w	l_k
RIK220.6075.06	60	75	10-17	15,7	13,4	$f_2+w/2$	6	36
RIK220.7595.06	75	95	17-25	15,7	13,4	$f_2+w/2$	6	36
RIK220.9513.06	95	130	25	15,7	13,4	$f_2+w/2$	6	36
RIK220.1318.06	130	180	25	15,7	13,4	$f_2+w/2$	6	36
RIK220.1830.06	180	300	25	15,7	13,4	$f_2+w/2$	6	36
RIK220.3000.06	300	1000	25	15,7	13,4	$f_2+w/2$	6	36

Für Grundhalter R...K1 und L...K2
For basic toolholder R...K1 and L...K2

Abmessungen in mm
Dimensions in mm

Weitere Abmessungen auf Anfrage
Further sizes upon request

Bestellhinweis:

Befestigungsschrauben der Kassetten gehören zum Lieferumfang des Grundhalters.

Ordering note:

The fastening screw is combined with the basic toolholder - no separate order required.

Das Anzugsdrehmoment der Schrauben finden Sie in den Technischen Hinweisen.

For torque specification of the screw, please see Technical Instructions.

Ersatzteile

Spare Parts

Kassette Cassette	Spannschraube Screw	TORX PLUS®-Schlüssel TORX PLUS® Wrench
RIK220...	6.23T25P	T25PQ

Axialeinstechen

Face Grooving



Kassette

Cassette

LAK220

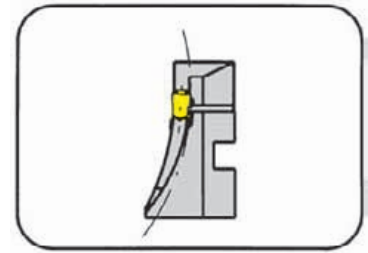

Nutaußen-Ø ab
Stechtiefe bis
Stechbreite

from outer groove Ø
Depth of groove up to
Width of groove

60 - 1000 mm
25 mm
4 - 5 mm

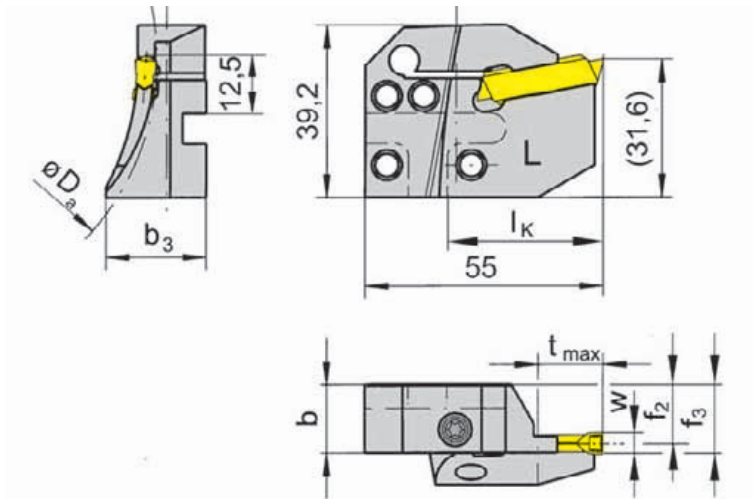

für Wendeschneidplatte
für Indexable insert

Typ S229
Type

L = Linksausführung
L = left hand version

Bestellnummer Part number	D _{a min}	D _{a max}	t _{max}	b	b ₃	f ₂	f ₃	w	l _k
LAK220.6575.04	65	75	10-17	15,7	23,0	14,4	f ₂ +w/2	4	36
LAK220.7595.04	75	95	15-25	15,7	23,0	14,4	f ₂ +w/2	4	36
LAK220.9513.04	95	130	25	15,7	21,2	14,4	f ₂ +w/2	4	36
LAK220.1318.04	130	180	25	15,7	21,2	14,4	f ₂ +w/2	4	36
LAK220.1830.04	180	300	25	15,7	21,2	14,4	f ₂ +w/2	4	36
LAK220.3000.04	300	1000	25	15,7	16,8	14,4	f ₂ +w/2	4	36
LAK220.6075.05	60	75	10-17	15,7	23,0	13,9	f ₂ +w/2	5	36
LAK220.7595.05	75	95	17-25	15,7	23,0	13,9	f ₂ +w/2	5	36
LAK220.9513.05	95	130	25	15,7	23,0	13,9	f ₂ +w/2	5	36
LAK220.1318.05	130	180	25	15,7	21,2	13,9	f ₂ +w/2	5	36
LAK220.1830.05	180	300	25	15,7	21,2	13,9	f ₂ +w/2	5	36
LAK220.3000.05	300	1000	25	15,7	16,8	13,9	f ₂ +w/2	5	36

Für Grundhalter L...K1 und R...K2
For basic toolholder L...K1 and R...K2

Weitere Abmessungen auf Anfrage
Further sizes upon request

Abmessungen in mm
Dimensions in mm

Bestellhinweis:

Befestigungsschrauben der Kassetten gehören zum Lieferumfang des Grundhalters.

Ordering note:

The fastening screw is combined with the basic toolholder - no separate order required.

Das Anzugsdrehmoment der Schrauben finden Sie in den Technischen Hinweisen.

For torque specification of the screw, please see Technical Instructions.

Ersatzteile

Spare Parts

Kassette Cassette	Spannschraube Screw	TORX PLUS®-Schlüssel TORX PLUS® Wrench
LAK220...	6.23T25P	T25PQ

Axialeinstechen

Face Grooving



Kassette

Cassette

LAK220

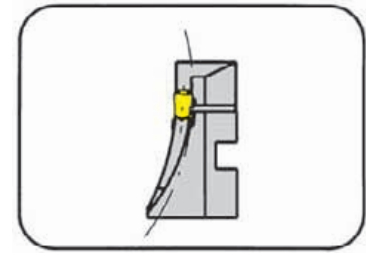

Nutaußen-Ø ab
Stechtiefe bis
Stechbreite

from outer groove Ø
Depth of groove up to
Width of groove

60 - 1000 mm
25 mm
6 mm

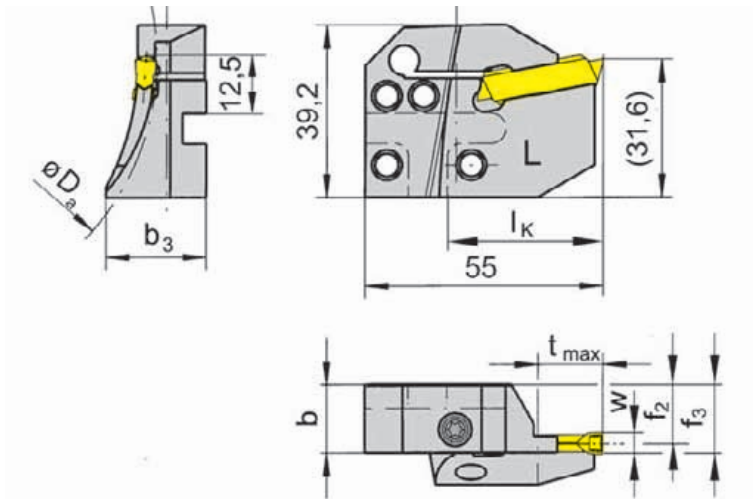

L = Linksausführung
L = left hand version

für Wendeschneidplatte
für Indexable insert

Typ S229
Type

Bestellnummer Part number	D _{a min}	D _{a max}	t _{max}	b	b ₃	f ₂	f ₃	w	l _k
LAK220.6075.06	60	75	10-17	15,7	23,0	13,4	f ₂ +w/2	6	36
LAK220.7595.06	75	95	17-25	15,7	23,0	13,4	f ₂ +w/2	6	36
LAK220.9513.06	95	130	25	15,7	23,0	13,4	f ₂ +w/2	6	36
LAK220.1318.06	130	180	25	15,7	21,2	13,4	f ₂ +w/2	6	36
LAK220.1830.06	180	300	25	15,7	21,2	13,4	f ₂ +w/2	6	36
LAK220.3000.06	300	1000	25	15,7	16,8	13,4	f ₂ +w/2	6	36

Für Grundhalter L...K1 und R...K2
For basic toolholder L...K1 and R...K2

Abmessungen in mm
Dimensions in mm

Weitere Abmessungen auf Anfrage
Further sizes upon request

Bestellhinweis:

Befestigungsschrauben der Kassetten gehören zum Lieferumfang des Grundhalters.

Ordering note:

The fastening screw is combined with the basic toolholder - no separate order required.

Das Anzugsdrehmoment der Schrauben finden Sie in den Technischen Hinweisen.

For torque specification of the screw, please see Technical Instructions.

Ersatzteile

Spare Parts

Kassette Cassette	Spannschraube Screw	TORX PLUS®-Schlüssel TORX PLUS® Wrench
LAK220...	6.23T25P	T25PQ

Axialeinstechen

Face Grooving



Kassette

Cassette

RAK220

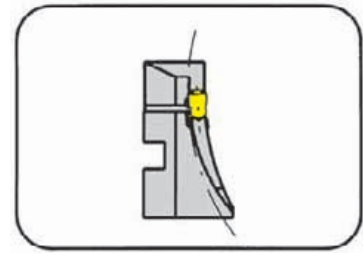

Nutaußen-Ø ab
Stechtiefe bis
Stechbreite

from outer groove Ø
Depth of groove up to
Width of groove

60 - 1000 mm
25 mm
4 - 5 mm

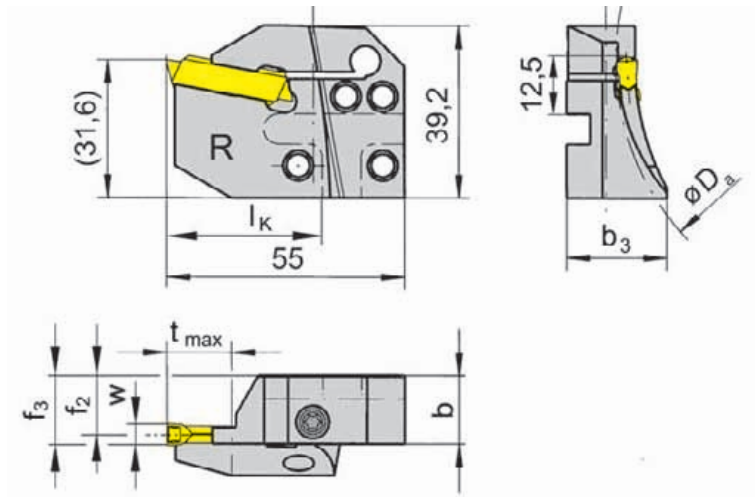

für Wendeschneidplatte
für Indexable insert

Typ S229
Type

R = Rechtsausführung
R = right hand version

Bestellnummer Part number	D _{a min}	D _{a max}	t _{max}	b	b ₃	f ₂	f ₃	w	l _k
RAK220.6575.04	65	75	10	15,7	23,0	14,4	f ₂ +w/2	4	36
RAK220.7595.04	75	95	15	15,7	23,0	14,4	f ₂ +w/2	4	36
RAK220.9513.04	95	130	25	15,7	21,2	14,4	f ₂ +w/2	4	36
RAK220.1318.04	130	180	25	15,7	21,2	14,4	f ₂ +w/2	4	36
RAK220.1830.04	180	300	25	15,7	21,2	14,4	f ₂ +w/2	4	36
RAK220.3000.04	300	1000	25	15,7	16,8	14,4	f ₂ +w/2	4	36
RAK220.6075.05	60	75	10	15,7	23,0	13,9	f ₂ +w/2	5	36
RAK220.7595.05	75	95	17	15,7	23,0	13,9	f ₂ +w/2	5	36
RAK220.9513.05	95	130	25	15,7	23,0	13,9	f ₂ +w/2	5	36
RAK220.1318.05	130	180	25	15,7	21,2	13,9	f ₂ +w/2	5	36
RAK220.1830.05	180	300	25	15,7	21,2	13,9	f ₂ +w/2	5	36
RAK220.3000.05	300	1000	25	15,7	16,8	13,9	f ₂ +w/2	5	36

Für Grundhalter R...K1 und L...K2
For basic toolholder R...K1 and L...K2

Weitere Abmessungen auf Anfrage
Further sizes upon request

Abmessungen in mm
Dimensions in mm

Bestellhinweis:

Befestigungsschrauben der Kassetten gehören zum Lieferumfang des Grundhalters.

Ordering note:

The fastening screw is combined with the basic toolholder - no separate order required.

Das Anzugsdrehmoment der Schrauben finden Sie in den Technischen Hinweisen.

For torque specification of the screw, please see Technical Instructions.

Ersatzteile

Spare Parts

Kassette Cassette	Spannschraube Screw	TORX PLUS®-Schlüssel TORX PLUS® Wrench
RAK220...	6.23T25P	T25PQ

Axialeinstechen

Face Grooving



Kassette

Cassette

RAK220

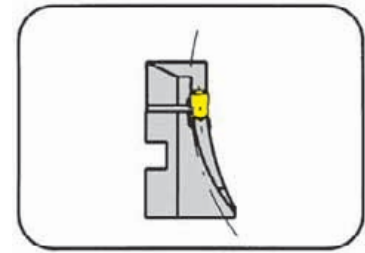

Nutaußen-Ø ab
Stechtiefe bis
Stechbreite

from outer groove Ø
Depth of groove up to
Width of groove

60 - 1000 mm
25 mm
6 mm

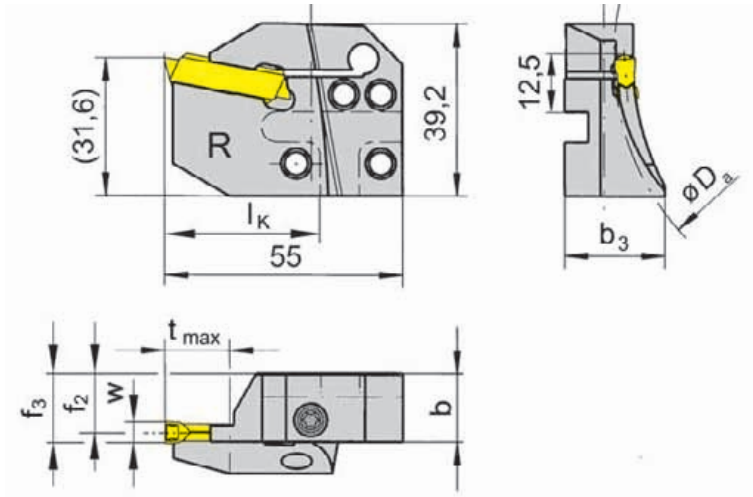

für Wendeschneidplatte
für Indexable insert

Typ S229
Type

R = Rechtsausführung
R = right hand version

Bestellnummer Part number	D _{a min}	D _{a max}	t _{max}	b	b ₃	f ₂	f ₃	w	l _k
RAK220.6075.06	60	75	10	15,7	23,0	13,4	f ₂ +w/2	6	36
RAK220.7595.06	75	95	17	15,7	23,0	13,4	f ₂ +w/2	6	36
RAK220.9513.06	95	130	25	15,7	23,0	13,4	f ₂ +w/2	6	36
RAK220.1318.06	130	180	25	15,7	21,2	13,4	f ₂ +w/2	6	36
RAK220.1830.06	180	300	25	15,7	21,2	13,4	f ₂ +w/2	6	36
RAK220.3000.06	300	1000	25	15,7	16,8	13,4	f ₂ +w/2	6	36

Für Grundhalter R...K1 und L...K2
For basic toolholder R...K1 and L...K2

Abmessungen in mm
Dimensions in mm

Weitere Abmessungen auf Anfrage
Further sizes upon request

Bestellhinweis:

Befestigungsschrauben der Kassetten gehören zum Lieferumfang des Grundhalters.

Ordering note:

The fastening screw is combined with the basic toolholder - no separate order required.

Das Anzugsdrehmoment der Schrauben finden Sie in den Technischen Hinweisen.

For torque specification of the screw, please see Technical Instructions.

Ersatzteile

Spare Parts

Kassette Cassette	Spannschraube Screw	TORX PLUS®-Schlüssel TORX PLUS® Wrench
RAK220...	6.23T25P	T25PQ

Axialeinstechen

Face Grooving



Wendeschneidplatte

Indexable insert

S229

mit Spanformrille
with chip former

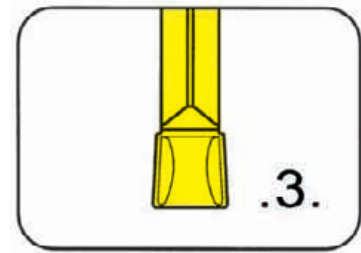

Stechtiefe bis Stechbreite	Depth of groove up to Width of groove	25 mm 4-6 mm
-------------------------------	--	-----------------

präzisionsgesintert
precision sintered

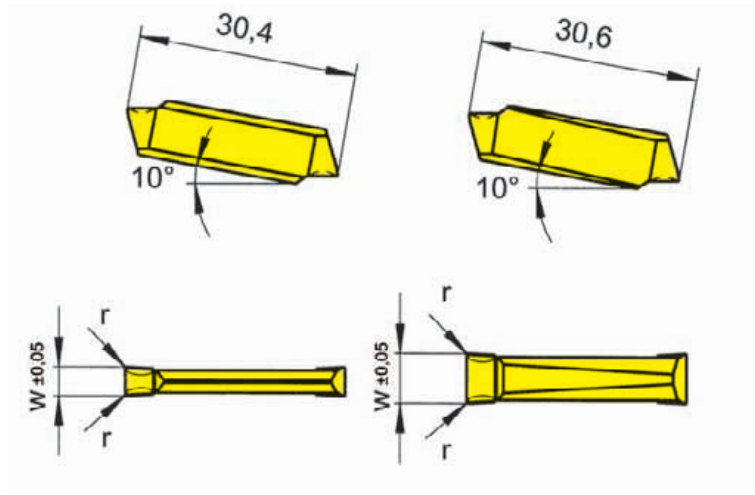

Schneidbreite 4,0 - 5,0 mm
Width 4,0 - 5,0 mm

Schneidbreite 6,0 mm
Width 6,0 mm

für Kassette
for Cassette

Typ R/LAK220
Type R/LIK220

Wechselgenauigkeit
Länge ± 0,06 mm
Indexability length ± 0,06 mm

Bestellnummer Part number	w	r	Größe Size	MG12	AL96	AS62	AS66	H54	P20	TA45	TC92	TF42	TF45	TI22	TI25	TN32	TN35	
				S229.0400.32	4	0,2	04	Δ	▲	▲	▲	▲	Δ	Δ	▲		▲	Δ
S229.0400.34	4	0,4	04	Δ	▲	▲	▲	▲	Δ	Δ	▲	▲	▲	Δ	▲	▲	▲	
S229.0500.34	5	0,4	04	Δ	▲	▲	▲	Δ	Δ	Δ	Δ		▲	▲	▲	▲	▲	
S229.0500.36	5	0,6	04					Δ	Δ	Δ	Δ			Δ	Δ	Δ	Δ	
S229.0600.34	6	0,4	05	Δ	▲	▲	▲	Δ	Δ	Δ	Δ		▲	Δ	▲	▲	▲	
S229.0600.38	6	0,8	05								Δ			Δ				
▲ ab Lager / on stock Δ 4 Wochen / 4 weeks				P	○	●	●	●	●	●	●	●	●	●	●	●	●	●
x auf Anfrage / upon request				M	●	-	-	○	●	-	●	-	●	-	●	-	●	●
● empfohlen / recommended				K	●	●	-	●	-	●	-	●	-	●	-	●	-	●
○ bedingt einsetzbar / alternative recommendation				N	●	●	-	●	-	●	-	●	-	●	-	●	-	●
- nicht geeignet / not suitable				S	●	●	-	○	-	●	-	●	-	●	-	●	-	●
■ unbeschichtete HM-Sorten / uncoated grades				H	-	-	-	-	-	-	-	-	-	-	-	-	-	-
■ beschichtete HM-Sorten / coated grades																		
■ bestückt/Cermet / brazed/Cermet																		

Abmessungen in mm
Dimensions in mm

HM-Sorten
Carbide grades

Wendeschneidplatten sind in rechten und linken Kassetten L/RAK220 und L/RIK220 verwendbar.
Indexable inserts can be used in right and left hand cassettes L/RAK220 and L/RIK220.

Axialeinstechen

Face Grooving



Wendeschneidplatte

Indexable insert

S229

mit Spanformung
with chip forming

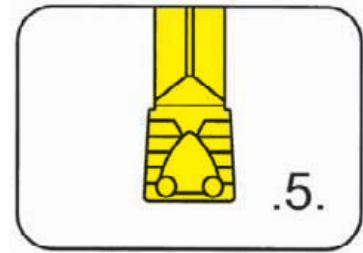

Stechtiefe bis Stechbreite	Depth of groove up to Width of groove	25 mm 4-6 mm
-------------------------------	--	-----------------

präzisionsgesintert
precision sintered

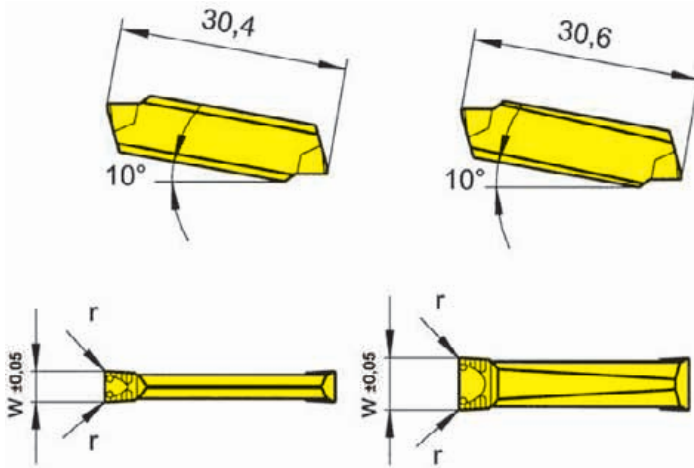

Schneidbreite 4,0 - 5,0 mm
Width 4,0 - 5,0 mm

Schneidbreite 6,0 mm
Width 6,0 mm

für Kassette
for Cassette

Typ R/LAK220
Type R/LIK220

Wechselgenauigkeit
Länge ± 0,06 mm
Indexability length ± 0,06 mm

Bestellnummer Part number	w	r	Größe Size	AL96	AS62	P20	TC92	TF45	TI22	TI25	TN32	TN35
S229.0400.52	4	0,2	04	Δ	▲	Δ	▲	▲	▲	▲	▲	▲
S229.0400.54	4	0,4	04	Δ	▲			▲	▲	▲	▲	▲
S229.0500.54	5	0,4	04	Δ	▲	Δ	▲	▲	▲	▲	▲	▲
S229.0500.56	5	0,6	06			x	Δ		x	Δ	Δ	Δ
S229.0600.54	6	0,4	05	Δ	▲	Δ	▲	▲		▲	▲	▲
S229.0600.56	6	0,6	05	Δ		x	Δ			Δ	Δ	Δ
▲ ab Lager / on stock				P	●	●	●	●	●	●	●	●
Δ 4 Wochen / 4 weeks				M	-	-	-	-	-	●	-	●
x auf Anfrage / upon request				K	●	-	-	-	-	●	-	●
● empfohlen / recommended				N	●	-	-	-	●	-	-	●
o bedingt einsetzbar / alternative recommendation				S	-	-	-	-	●	●	-	●
- nicht geeignet / not suitable				H	-	-	-	-	-	-	-	-
unbeschichtete HM-Sorten / uncoated grades												
beschichtete HM-Sorten / coated grades												
bestückt/Cermet / brazed/Cermet												

Abmessungen in mm
Dimensions in mm

Wendeschneidplatten sind in rechten und linken Kassetten L/RAK220 und L/RIK220 verwendbar.
Indexable inserts can be used in right and left hand cassettes L/RAK220 and L/RIK220.

HM-Sorten
Carbide grades



Axialeinstechen

Face Grooving



Wendeschneidplatte

Indexable insert

S229

mit Spanformung
with chip forming



Stechtiefe bis Stechbreite	Depth of groove up to Width of groove	25 mm 4-6 mm
-------------------------------	--	-----------------

präzisionsgesintert
precision sintered

für Kassette
for Cassette

Typ R/LAK220
Type R/LIK220

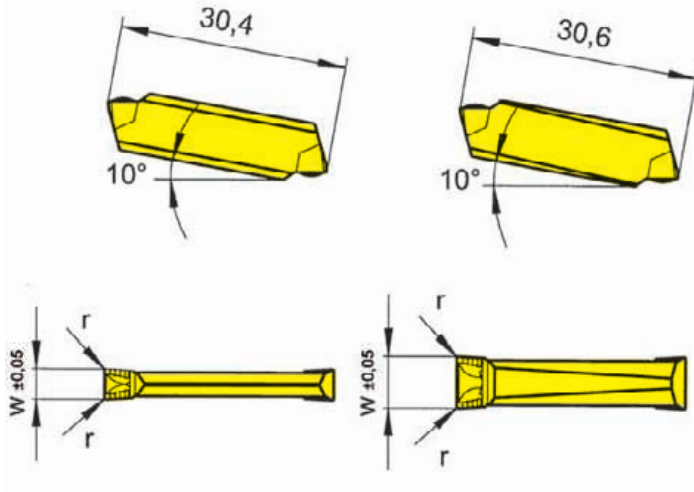

Schneidbreite 4,0 - 5,0 mm
Width 4,0 - 5,0 mm

Schneidbreite 6,0 mm
Width 6,0 mm

Wechselgenauigkeit
Länge ± 0,06 mm
Indexability length ± 0,06 mm

Bestellnummer Part number	w	r	Größe Size	AL96	AS62	P20	TC92	TF42	TF45	TI22	TI25	TN32	TN35
S229.0400.A2	4	0,2	04	Δ	▲	Δ	Δ		▲	▲	▲	▲	▲
S229.0400.A4	4	0,4	04	Δ	▲		Δ	▲	Δ	▲	▲	▲	▲
S229.0500.A4	5	0,4	04		▲		Δ		Δ	▲	Δ	▲	▲
S229.0600.A4	6	0,4	05	Δ	▲	Δ	Δ	Δ	▲	▲	Δ	▲	▲
▲ ab Lager / on stock Δ 4 Wochen / 4 weeks x auf Anfrage / upon request				P	●	●	●	●	●	●	●	●	●
● empfohlen / recommended				M	-	-	-	-	-	-	-	-	-
o bedingt einsetzbar / alternative recommendation				K	●	-	-	-	-	-	-	-	-
- nicht geeignet / not suitable				N	●	-	-	-	-	-	-	-	-
■ unbeschichtete HM-Sorten / uncoated grades				S	-	-	-	-	-	-	-	-	-
■ beschichtete HM-Sorten / coated grades				H	-	-	-	-	-	-	-	-	-
■ bestückt/Cermet / brazed/Cermet													

Abmessungen in mm
Dimensions in mm

HM-Sorten
Carbide grades

Wendeschneidplatten sind in rechten und linken Kassetten L/RAK220 und L/RIK220 verwendbar.
Indexable inserts can be used in right and left hand cassettes L/RAK220 and L/RIK220.

Axialeinstechen

Face Grooving



Wendeschneidplatte

Indexable insert

S229

mit Spanformung
with chip forming

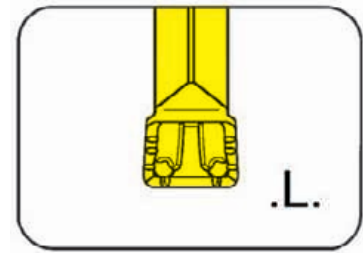

Stechtiefe bis
Stechbreite

Depth of groove up to
Width of groove

25 mm
4-6 mm

präzisionsgesintert
precision sintered

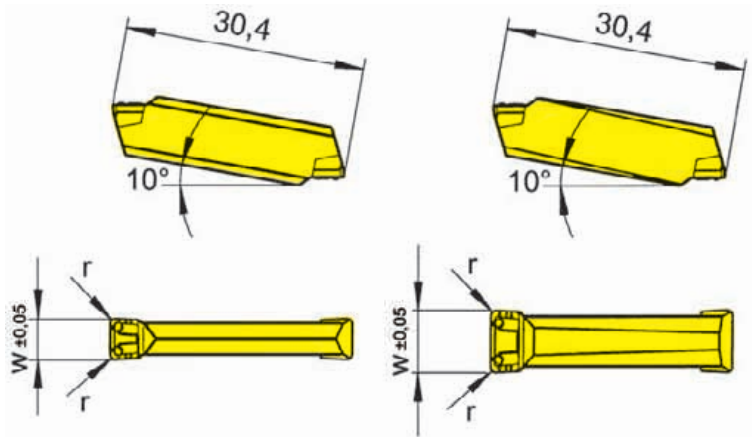

Schneidbreite 4,0 - 5,0 mm
Width 4,0 - 5,0 mm

Schneidbreite 6,0 mm
Width 6,0 mm

für Kassette
for Cassette

Typ R/LAK220
Type R/LIK220

Wechselgenauigkeit
Länge ± 0,06 mm
Indexability length ± 0,06 mm

Bestellnummer Part number	w	r	Größe Size	AL96	AS62	AS66	TF42	Ti22
				▲	▲	▲	▲	▲
S229.0400.L4	4	0,4	04	▲	▲	▲	▲	▲
S229.0500.L4	5	0,4	04	▲	▲	▲	▲	▲
S229.0500.L6	5	0,6	04	▲	▲	▲	▲	▲
S229.0600.L4	6	0,4	05	▲	▲	▲	▲	▲
S229.0600.L6	6	0,6	05	▲	▲	▲	▲	▲
P	•	•	•	•	•	•	•	•
M	-	-	o	-	-	-	-	-
K	•	-	•	-	-	-	-	-
N	•	-	•	-	-	-	-	-
S	-	-	o	-	-	-	-	-
H	-	-	-	-	-	-	-	-

▲ ab Lager / on stock Δ 4 Wochen / 4 weeks x auf Anfrage / upon request

• empfohlen / recommended

o bedingt einsetzbar / alternative recommendation

- nicht geeignet / not suitable

■ unbeschichtete HM-Sorten / uncoated grades

■ beschichtete HM-Sorten / coated grades

■ bestückt/Cermet / brazed/Cermet

Abmessungen in mm

Dimensions in mm

Wendeschneidplatten sind in rechten und linken Kassetten L/RAK220 und L/RIK220 verwendbar.

Indexable inserts can be used in right and left hand cassettes L/RAK220 and L/RIK220.

HM-Sorten
Carbide grades



Axialeinstechen

Face Grooving



Schneidplatte

Insert

229

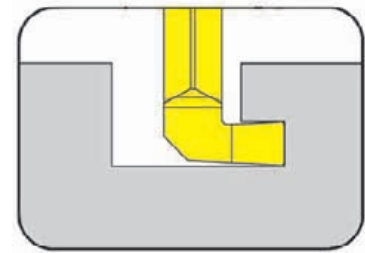

Stechtiefe bis Stechbreite	Depth of groove up to Width of groove	4 mm 3-4 mm
-------------------------------	--	----------------

für Kassette
for Cassette

Typ R/LAK220
Type R/LIK220

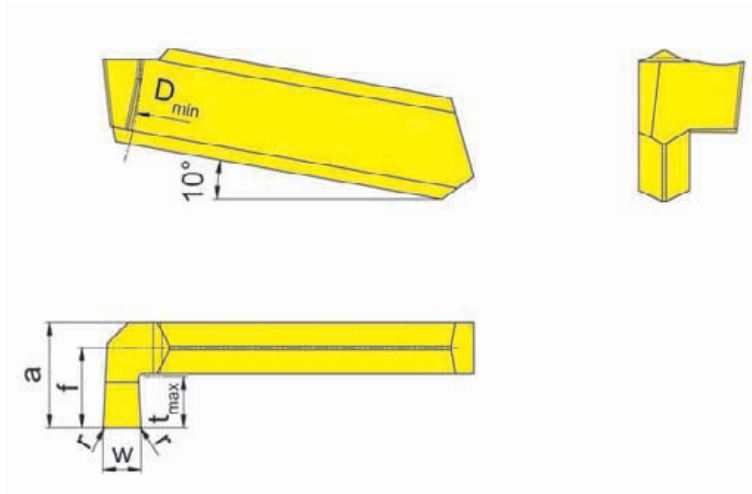

R = rechts wie gezeichnet
R = right hand version shown

L = links spiegelbildlich
L = left hand version

Bestellnummer Part number	w	r	t _{max}	a	f	D _{min}	Größe Size	AS65
R/L229.3040.HA50.12	3	0,2	4	8,3	6,3	50	03	▲▲
R/L229.4040.HA50.12	4	0,2	4	8,3	6,3	50	04	▲▲

▲ ab Lager / on stock Δ 4 Wochen / 4 weeks x auf Anfrage / upon request

● empfohlen / recommended

o bedingt einsetzbar / alternative recommendation

- nicht geeignet / not suitable

■ unbeschichtete HM-Sorten / uncoated grades

■ beschichtete HM-Sorten / coated grades

■ bestückt/Cermet / brazed/Cermet

Abmessungen in mm

Dimensions in mm

Ausführung R oder L angeben

State R or L version

P	●
M	○
K	○
N	-
S	-
H	-

HM-Sorten
Carbide grades



Axialeinstechen

Face Grooving



Klemmhalter
Toolholder
221/228

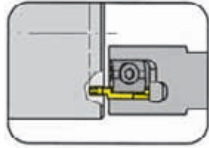

Seite/Page
S92-S93

Wendeschneidplatte
Indexable insert
231

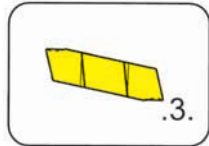

Seite/Page
S94

S

231



**Klemmhalter mit
Schneidplatten**

Stechbreite 3,0 - 10,0 mm

**Toolholder with
Inserts**

Width of groove 3,0 - 10,0 mm

Axialeinstechen

Face Grooving



Klemmhalter

Toolholder

221

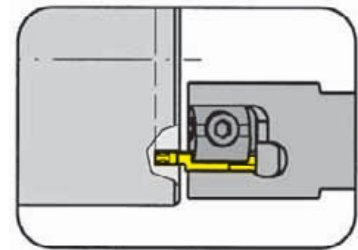

Nutaußen-Ø ab	from outer groove Ø	40 mm
Stechtiefe bis	Depth of groove up to	8 mm
Spannbereich	Clamping range	3,0 - 10,0 mm

Wendeschneidplatte
Indexable insert

Typ 231
Type N231

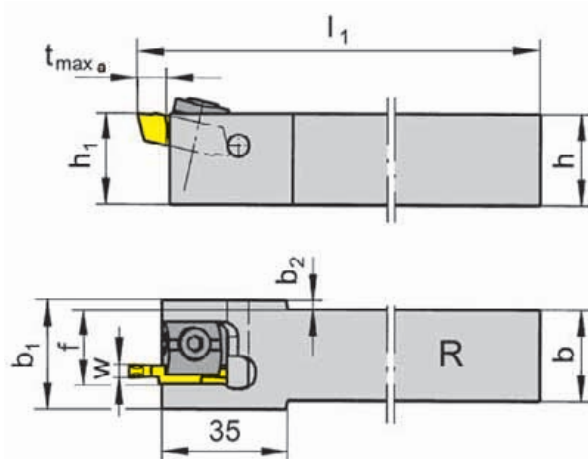

R = rechts wie gezeichnet
R = right hand version shown

L = links spiegelbildlich
L = left hand version

Bestellnummer Part number	h	b	l ₁	h ₁	b ₁	f	t _{max a}	b ₂	D _{a min}	Größe Size	Spannbereich Clamping range
R/L221.2020.04	20	20	125	20	28	17,9	8	4,0	40	04	3,0-4,0
R/L221.2525.04	25	25	150	25	28	20,4	8	1,5	40	04	3,0-4,0
R/L221.2020.05	20	20	125	20	30	18,9	8	5,0	40	05	4,1-6,0
R/L221.2525.05	25	25	150	25	30	21,4	8	2,5	40	05	4,1-6,0
R/L221.2020.07	20	20	125	20	32	19,9	8	6,0	40	07	6,1-8,0
R/L221.2525.07	25	25	150	25	32	22,4	8	3,5	40	07	6,1-8,0
R/L221.2020.09	20	20	125	20	34	20,9	8	7,0	40	09	8,1-10,0
R/L221.2525.09	25	25	150	25	34	23,4	8	4,5	40	09	8,1-10,0

Ausführung R oder L angeben
State R or L version

w siehe WSP
w see indexable inserts

Abmessungen in mm
Dimensions in mm

Weitere Abmessungen auf Anfrage
Further sizes upon request

Dieser Klemmhalter ist in Abhängigkeit der Stechtiefe von D_a = 30 mm bis ∞ einsetzbar.
This toolholder can be used from D_a = 30 mm up to ∞ depending on grooving depth.

Das Anzugsdrehmoment der Schrauben finden Sie in den Technischen Hinweisen.
For torque specification of the screw, please see Technical Instructions.

Ersatzteile

Spare Parts

Klemmhalter Toolholder	Anschlagstift Stop Pin	Spannelement Clamping element	TORX PLUS®-Schlüssel TORX PLUS® Wrench
R/L221...	3.6.28	01.60.12	T20PQ

Axialeinstechen

Face Grooving



Klemmhalter

Toolholder

228

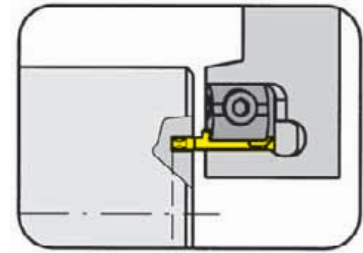

Nutaußen-Ø ab	from outer groove Ø	40 mm
Stechtiefe bis	Depth of groove up to	8 mm
Spannbereich	Clamping range	3,0 - 10,0 mm

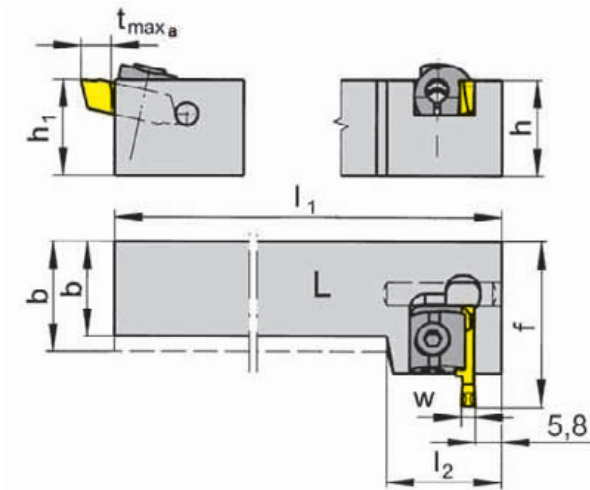

Wendeschneidplatte
Indexable insert

Typ 231
Type N231

L = links wie gezeichnet
L = left hand version shown

R = rechts spiegelbildlich
R = right hand version

Bestellnummer Part number	h	b	h ₁	f	t _{max a}	D _{a min}	l ₁	l ₂	Größe Size	Spannbereich Clamping range
R/L228.2020.04	20	20	20	38,5	8	40	125	35,5	04	3,0-4,0
R/L228.2525.04	25	25	25	38,5	8	40	150	35,5	04	3,0-4,0
R/L228.2020.05	20	20	20	38,5	8	40	125	35,5	05	4,1-6,0
R/L228.2525.05	25	25	25	38,5	8	40	150	35,5	05	4,1-6,0
R/L228.2020.07	20	20	20	38,5	8	40	125	35,5	07	6,1-8,0
R/L228.2525.07	25	25	25	38,5	8	40	150	35,5	07	6,1-8,0
R/L228.2020.09	20	20	20	38,5	8	40	125	35,5	09	8,1-10,0
R/L228.2525.09	25	25	25	38,5	8	40	150	35,5	09	8,1-10,0

Ausführung R oder L angeben
State R or L version

w siehe WSP
w see indexable inserts

Abmessungen in mm
Dimensions in mm

Weitere Abmessungen auf Anfrage
Further sizes upon request

Dieser Klemmhalter ist in Abhängigkeit der Stechtiefe von D_a = 30 mm bis ∞ einsetzbar.
This toolholder can be used from D_a = 30 mm up to ∞ depending on grooving depth.

Das Anzugsdrehmoment der Schrauben finden Sie in den Technischen Hinweisen.
For torque specification of the screw, please see Technical Instructions.

Ersatzteile

Spare Parts

Klemmhalter Toolholder	Anschlagstift Stop Pin	Spannelement Clamping element	TORX PLUS®-Schlüssel TORX PLUS® Wrench
R/L228...	3.6.28	01.60.12	T20PQ

Axialeinstechen

Face Grooving



Wendeschneidplatte

Indexable insert

231

mit Spanformrille
with chip former

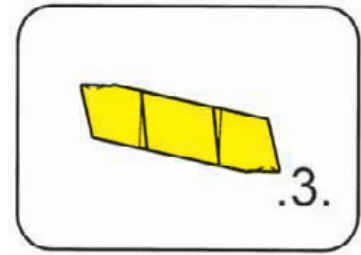

Nutaußen-Ø	outer groove Ø	40 mm
Stechtiefe bis	Depth of groove up to	8 mm
Stechbreite	Width of groove	3-10 mm

Klemhalter
Toolholder

Typ 221
Type 228

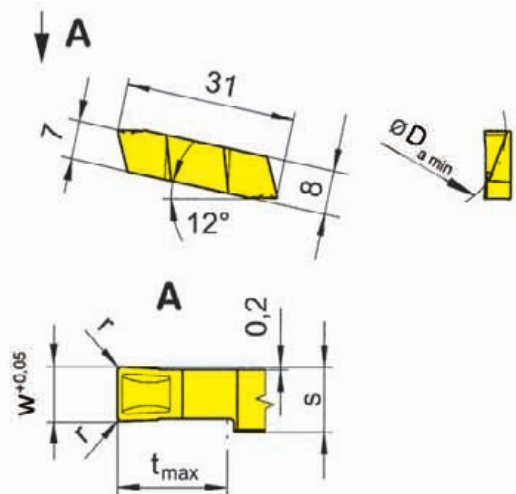

Wechselgenauigkeit
Länge ± 0,025 mm
Indexability length ± 0,025 mm

Bestellnummer Part number	w	r	t _{max}	s	D _{a min}	Größe Size	TN35
R/L231.4030.32	3	0,2	8	3,8	40	04	▲▲
R/L231.4040.32	4	0,2	8	3,8	40	04	▲▲
R/L231.4050.34	5	0,4	8	5,8	40	05	▲▲
N231.4060.34	6	0,4	8	5,8	40	05	▲
N231.4070.36	7	0,6	8	7,8	40	07	△
N231.4080.36	8	0,6	8	7,8	40	07	▲
N231.4090.38	9	0,8	8	9,8	40	09	△
N231.4100.38	10	0,8	8	9,8	40	09	▲

▲ ab Lager / on stock △ 4 Wochen / 4 weeks x auf Anfrage / upon request

● empfohlen / recommended

o bedingt einsetzbar / alternative recommendation

- nicht geeignet / not suitable

■ unbeschichtete HM-Sorten / uncoated grades

■ beschichtete HM-Sorten / coated grades

■ bestückt/Cermet / brazed/Cermet

Abmessungen in mm

Dimensions in mm

Ausführung R, L oder N angeben

State R, L or N version

Bei Nutaußen-Ø < 40 mm bitten wir um Anfrage.

Outer-Ø of groove < 40 mm upon request.

P	•
M	•
K	•
N	•
S	•
H	-

HM-Sorten
Carbide grades



Axialeinstechen

Face Grooving

Klemmhalter
Toolholder
360/369

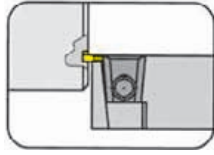

Seite/Page
S98-S99

Wendeschneidplatte
Indexable insert
312

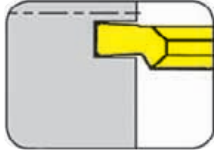

Seite/Page
S100

312



**Klemmhalter mit
Schneidplatten**

Stechbreite 1,5 - 3 mm

**Toolholder with
Inserts**

Width of groove 1,5 - 3 mm

Axialeinstechen

Face Grooving



Klemmhalter

Toolholder

360

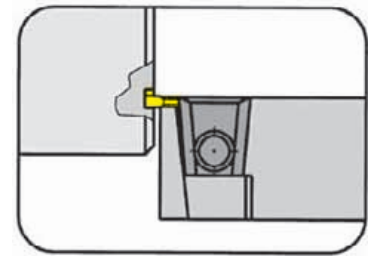

Nutaußen-Ø ab	from outer groove Ø	20 mm
Stechtiefe bis	Depth of groove up to	6 mm
Spannbereich	Clamping range	1,9 - 3,9 mm

für Wendeschneidplatte
for Indexable insert

Typ 312
Type S312

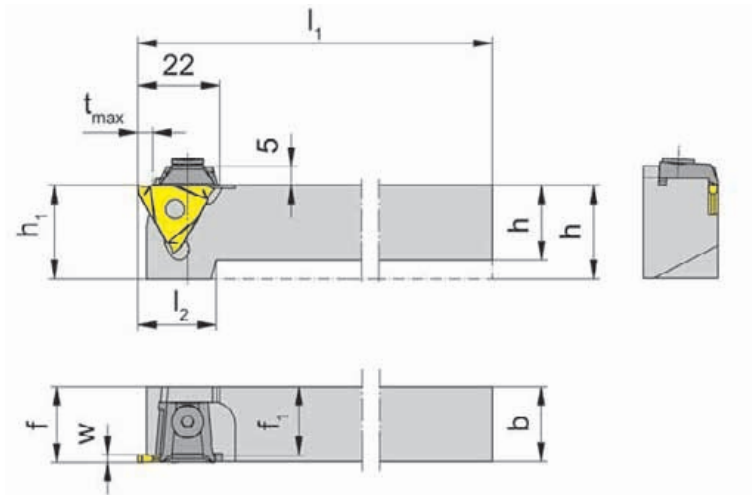

R = rechts wie gezeichnet
R = right hand version shown

L = links spiegelbildlich
L = left hand version

Bestellnummer Part number	h	b	l ₁	l ₂	h ₁	f ₁	f	t _{max}	Größe Size	Spannbereich Clamping range
R/L360.1212.02	12	12	100	24	25	9,5	f ₁ +w-a ₁	6	02	1,9-2,9
R/L360.1616.02	16	16	125	22	25	13,5	f ₁ +w-a ₁	6	02	1,9-2,9
R/L360.2020.02	20	20	125	21	25	17,5	f ₁ +w-a ₁	6	02	1,9-2,9
R/L360.2525.02	25	25	150	-	25	22,5	f ₁ +w-a ₁	6	02	1,9-2,9
R/L360.3232.02	32	32	170	-	32	29,5	f ₁ +w-a ₁	6	02	1,9-2,9
R/L360.1212.03	12	12	100	24	25	8,5	f ₁ +w-a ₁	6	03	2,9-3,9
R/L360.1616.03	16	16	125	22	25	12,5	f ₁ +w-a ₁	6	03	2,9-3,9
R/L360.2020.03	20	20	125	21	25	16,5	f ₁ +w-a ₁	6	03	2,9-3,9
R/L360.2525.03	25	25	150	-	25	21,5	f ₁ +w-a ₁	6	03	2,9-3,9
R/L360.3232.03	32	32	170	-	32	28,5	f ₁ +w-a ₁	6	03	2,9-3,9

Ausführung R oder L angeben
State R or L version

w, a₁ siehe WSP
w, a₁ see indexable inserts

Abmessungen in mm
Dimensions in mm

Das Anzugsdrehmoment der Schrauben finden Sie in den Technischen Hinweisen.
For torque specification of the screw, please see Technical Instructions.

Ersatzteile

Spare Parts

Klemmhalter Toolholder	Inbus-Schlüssel Wrench	Spannelement Clamping element
R/L360...	SW3,0 DIN911	11.3
R/L360...	SW3,0 DIN911	16.4

Axialeinstechen

Face Grooving



Klemmhalter

Toolholder

369

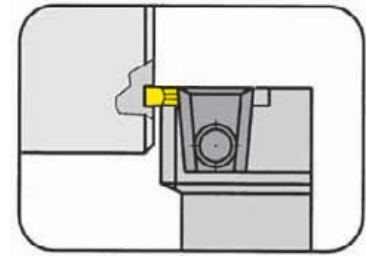

Nutaußen-Ø ab	from outer groove Ø	20 mm
Stechtiefe bis	Depth of groove up to	6 mm
Spannbereich	Clamping range	1,9 - 3,9 mm

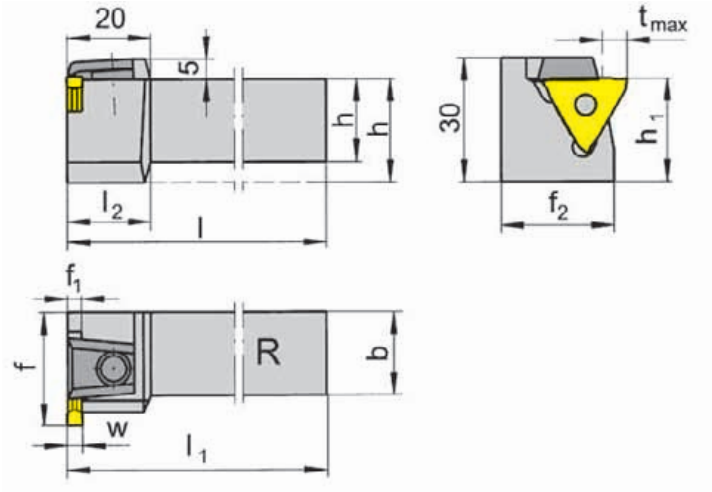

für Wendeschneidplatte
for Indexable insert

Typ 312
Type S312

R = rechts wie gezeichnet
R = right hand version shown

L = links spiegelbildlich
L = left hand version

Bestellnummer Part number	h	b	l ₂	h ₁	f	t _{max}	l ₁	l	f ₁	f ₂	Größe Size	Spannbereich Clamping range
R/L369.2020.02	20	20	20	25	27	6	l-f ₁ +w-a ₁	125	2,5	23,5	02	1,9-2,9
R/L369.2525.02	25	25	-	25	32	6	l-f ₁ +w-a ₁	150	2,5	28,5	02	1,9-2,9
R/L369.2020.03	20	20	20	25	27	6	l-f ₁ +w-a ₁	125	3,5	23,5	03	2,9-3,9
R/L369.2525.03	25	25	-	25	32	6	l-f ₁ +w-a ₁	150	3,5	28,5	03	2,9-3,9

Ausführung R oder L angeben
State R or L version

w, a₁ siehe WSP
w, a₁ see indexable inserts

Abmessungen in mm
Dimensions in mm

Weitere Abmessungen auf Anfrage
Further sizes upon request

Das Anzugsdrehmoment der Schrauben finden Sie in den Technischen Hinweisen.
For torque specification of the screw, please see Technical Instructions.

Ersatzteile

Spare Parts

Klemmhalter Toolholder	Inbus-Schlüssel Wrench	Spannelement Clamping element
R/L369...	SW3,0 DIN911	16.4

Axialeinstechen

Face Grooving



Wendeschneidplatte

Indexable insert

312

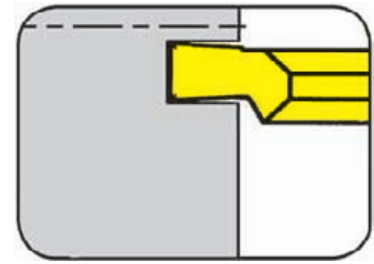

Nutaußen-Ø ab	from outer groove Ø	20 mm
Stechtiefe bis	Depth of groove up to	3 mm
Stechbreite	Width of groove	1,5-3 mm

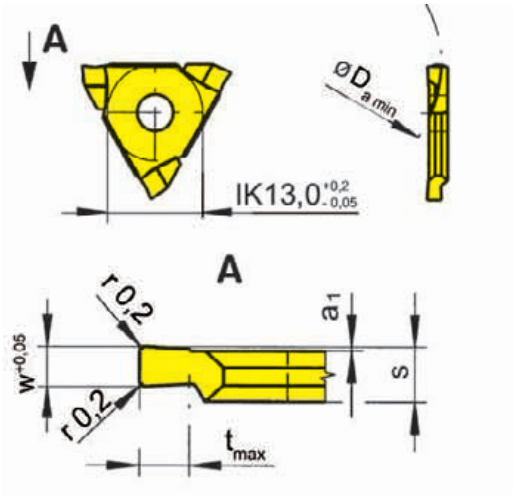

für Klemmhalter
for Toolholder

Typ 360
Type 369

Wechselgenauigkeit
Länge ± 0,02 mm
Indexability length ± 0,02 mm

R = rechts wie gezeichnet
R = right hand version shown

L = links spiegelbildlich
L = left hand version

Bestellnummer Part number	w	t _{max}	a ₁	s	D _{a min}	Größe Size	EG55	TN35
R/L312.2015.02	1,5	2	0,2	2,7	20	02	▲/▲	▲/▲
R/L312.3030.02	3,0	3	0,2	3,7	30	03	▲/▲	▲/▲

- ▲ ab Lager / on stock Δ 4 Wochen / 4 weeks x auf Anfrage / upon request
- empfohlen / recommended
- o bedingt einsetzbar / alternative recommendation
- nicht geeignet / not suitable
- unbeschichtete HM-Sorten / uncoated grades
- beschichtete HM-Sorten / coated grades
- bestückt/Cermet / brazed/Cermet

P	●	●
M	○	●
K	○	●
N	-	●
S	-	●
H	-	-

HM-Sorten
Carbide grades

Abmessungen in mm
Dimensions in mm

Ausführung R oder L angeben
State R or L version

Hinweis für Klemmhalter Typ 360

Rechte WSP in linken, linke WSP in rechten Klemmhaltern verwenden.

Note for toolholder type 360

Use right hand inserts in left hand toolholders and left hand inserts in right hand toolholders

Hinweis für Klemmhalter Typ 369

Rechte WSP in rechten, linke WSP in linken Klemmhaltern verwenden.

Note for toolholder type 369

Use right hand inserts in right hand toolholders and left hand inserts in left hand toolholders



Klemmhalter
Toolholder
356/357

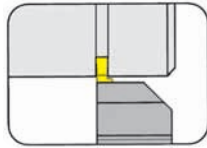

Seite/Page
S104-S105

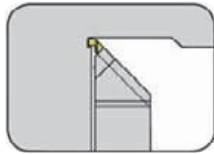

Seite/Page
S106

Wendeschneidplatte
Indexable insert
A315

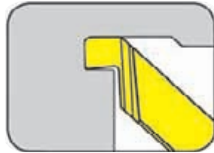

Seite/Page
S107, S109

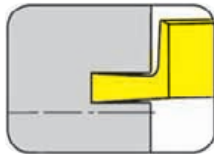

Seite/Page
S108

S

A315



S

**Klemmhalter mit
Schneidplatten**

Stechbreite 1,5 - 3 mm

**Toolholder with
Inserts**

Width of groove 1,5 - 3 mm

Einstecken/Gewindedrehen (außen)

Grooving and Threading (external)



Klemmhalter

Toolholder

356

Stechtiefe bis Stechbreite	Depth of groove up to Width of groove	5 mm 0,5 - 7,3 mm
-------------------------------	--	----------------------

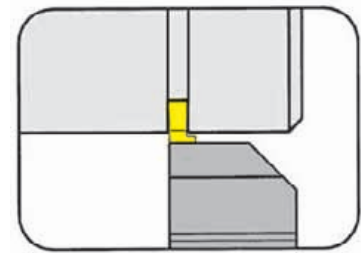

für Wendeschneidplatte
for Indexable insert

Typ LA315
Type RA315

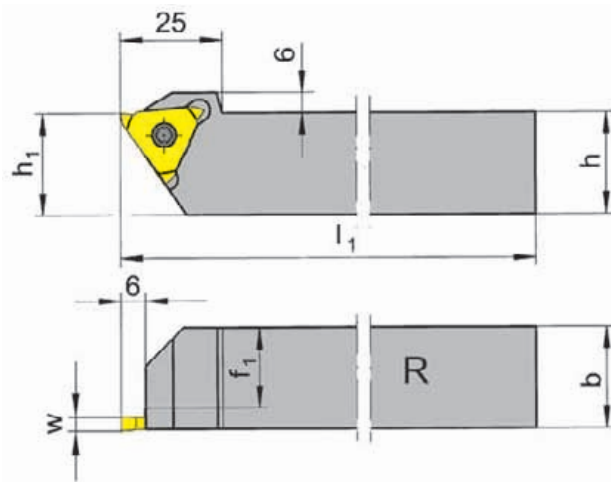

R = rechts wie gezeichnet
R = right hand version shown

L = links spiegelbildlich
L = left hand version

Bestellnummer Part number	h	b	l ₁	h ₁	f ₁	Größe Size
R/L356.1616.03	16	16	125	20	13,0	03
R/L356.1616.05	16	16	125	20	10,8	05
R/L356.2020.03	20	20	125	20	17,0	03
R/L356.2020.05	20	20	125	20	14,8	05
R/L356.2020.07	20	20	125	20	13,0	07
R/L356.2525.03	25	25	150	25	22,0	03
R/L356.2525.05	25	25	150	25	19,8	05
R/L356.2525.07	25	25	150	25	18,0	07
R/L356.3232.03	32	32	170	32	29,0	03
R/L356.3232.05	32	32	170	32	26,8	05
R/L356.3232.07	32	32	170	32	25,0	07

Ausführung R oder L angeben
State R or L version

w siehe WSP
w see indexable inserts

Abmessungen in mm
Dimensions in mm

Weitere Abmessungen auf Anfrage
Further sizes upon request

Das Anzugsdrehmoment der Schrauben finden Sie in den Technischen Hinweisen.
For torque specification of the screw, please see Technical Instructions.

Ersatzteile

Spare Parts

Klemmhalter Toolholder	Spannschraube Screw	TORX PLUS®-Schlüssel TORX PLUS® Wrench
R/L356...	5.12T20P	T20PQ
R/L356...	5.15T20P	T20PQ

Einstecken/Gewindedrehen (außen)

Grooving and Threading (external)



Klemmhalter

Toolholder

357

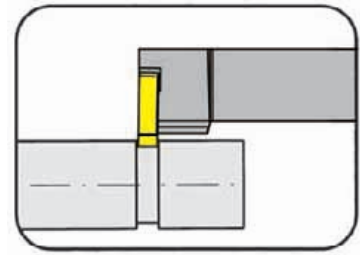

Stechtiefe bis Stechbreite	Depth of groove up to Width of groove	5 mm 0,5 - 5,3 mm
-------------------------------	--	----------------------

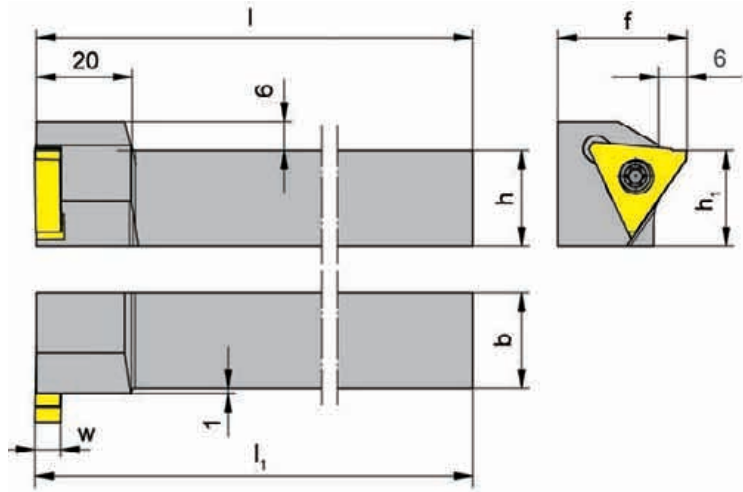

R = rechts wie gezeichnet
R = right hand version shown

L = links spiegelbildlich
L = left hand version

für Wendeschneidplatte
for Indexable insert

Typ LA315
Type RA315



Bestellnummer Part number	h	b	l ₁	h ₁	f	l	Größe Size
R/L357.2020.05	20	20	125,3	20	27	125	05
R/L357.2525.05	25	25	150,3	25	32	150	05

Ausführung R oder L angeben
State R or L version

w siehe WSP
w see indexable inserts

Abmessungen in mm
Dimensions in mm

Weitere Abmessungen auf Anfrage
Further sizes upon request

Bestellhinweis:

Rechte WSP in linken, linke WSP in rechten Klemmhaltern verwenden.

Ordering note:

Use right hand inserts in left hand toolholders and left hand inserts in right hand toolholders

Das Anzugsdrehmoment der Schrauben finden Sie in den Technischen Hinweisen.

For torque specification of the screw, please see Technical Instructions.

Ersatzteile

Spare Parts

Klemmhalter Toolholder	Spannschraube Screw	TORX PLUS®-Schlüssel TORX PLUS® Wrench
R/L357...	5.12T20P	T20PQ

Eckenfreistechen (außen)

Grooving Corner Reliefs (external)



Klemmhalter
Toolholder

356

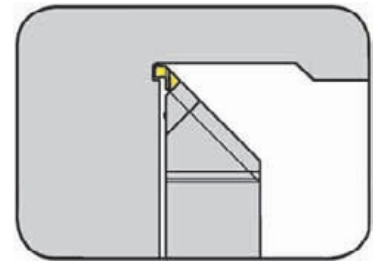

Eckenfreistiche (45°)
Corner reliefs (45°)

für Wendeschneidplatte
for Indexable insert

Typ LA315...45...R
Type RA315...45...L

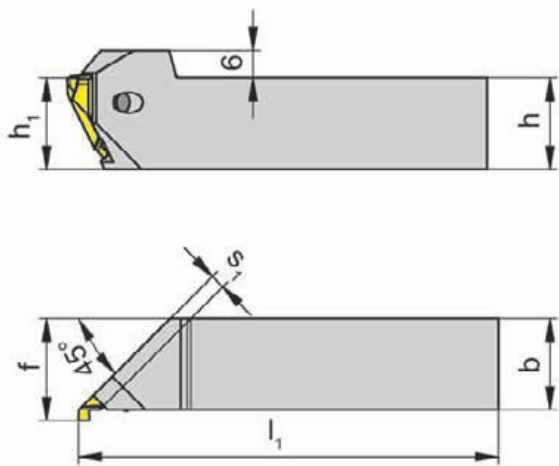

R = rechts wie gezeichnet
R = right hand version shown

L = links spiegelbildlich
L = left hand version

Bestellnummer Part number	h	b	l ₁	h ₁	f	s ₁	Größe Size
R/L356.2020.45.03	20	20	125	20	22,3	3,25	03
R/L356.2525.45.03	25	25	150	25	27,3	3,25	03

Ausführung R oder L angeben
State R or L version

Abmessungen in mm
Dimensions in mm

Bestellhinweis:

Rechte WSP in linken, linke WSP in rechten Klemmhaltern verwenden.

Ordering note:

Use right hand inserts in left hand toolholders and left hand inserts in right hand toolholders

Das Anzugsdrehmoment der Schrauben finden Sie in den Technischen Hinweisen.

For torque specification of the screw, please see Technical Instructions.

Ersatzteile

Spare Parts

Klemmhalter Toolholder	Spannschraube Screw	TORX PLUS®-Schlüssel TORX PLUS® Wrench
R/L356...	5F.08T20P	T20PQ

Axialeinstechen

Face Grooving



Wendeschneidplatte

Indexable insert

A315

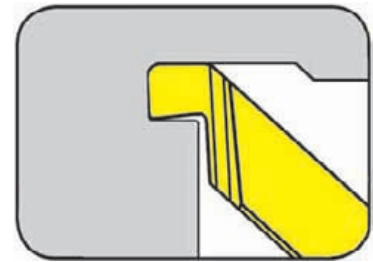

Nutaußen-Ø ab	from outer groove Ø	8 mm
Stechtiefe bis	Depth of groove up to	2 mm
Stechbreite	Width of groove	1,5-2,4 mm

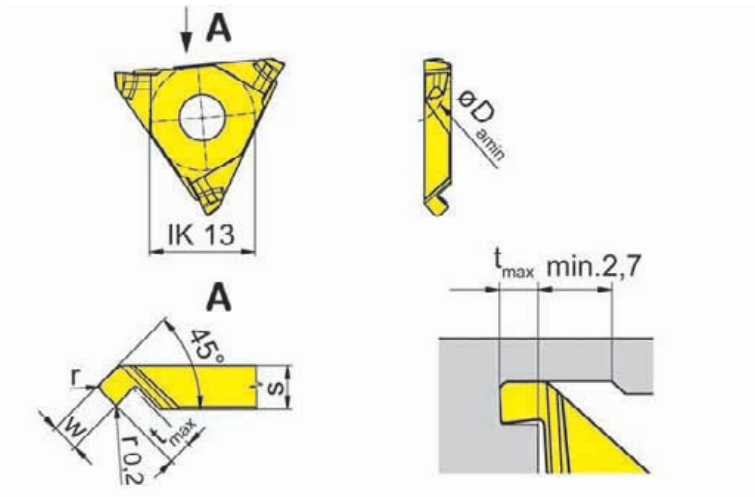

L = links wie gezeichnet
L = left hand version shown

R = rechts spiegelbildlich
R = right hand version

für Klemhalter
for Toolholder

Typ R/L356...45.03
Type

Wechselgenauigkeit
Länge ± 0,02 mm
Indexability length ± 0,02 mm

Bestellnummer Part number	w	r	t _{max}	D _{a min}	s	Größe Size	TH35	TN35
RA315.0815.45.04L	1,5	0,4	1,6	8	3,25	03	▲	▲
RA315.1220.45.05L	2,0	0,5	1,8	12	3,25	03	▲	▲
RA315.2024.45.06L	2,4	0,6	2,0	20	3,25	03	▲	▲
LA315.0815.45.04R	1,5	0,4	1,6	8	3,25	03	▲	▲
LA315.1220.45.05R	2,0	0,5	1,8	12	3,25	03	▲	▲
LA315.2024.45.06R	2,4	0,6	2,0	20	3,25	03	▲	▲

▲ ab Lager / on stock Δ 4 Wochen / 4 weeks x auf Anfrage / upon request

● empfohlen / recommended

o bedingt einsetzbar / alternative recommendation

- nicht geeignet / not suitable

□ unbeschichtete HM-Sorten / uncoated grades

■ beschichtete HM-Sorten / coated grades

■ bestückt/Cermet / brazed/Cermet

Abmessungen in mm

Dimensions in mm

Ausführung R oder L angeben

State R or L version

Hinweis für Klemhalter Typ 356...45..

Rechte WSP in linken, linke WSP in rechten Klemmhaltern verwenden.

Note for toolholder type 356...45..

Use right hand inserts in left hand toolholders and left hand inserts in right hand toolholders

Der Freistich muss VOR der Axialbearbeitung eingebracht werden!

The undercut must be placed BEFORE the axial machining!

P	•	•
M	•	•
K	•	•
N	•	•
S	•	•
H	-	-

HM-Sorten
Carbide grades



Axialeinstechen

Face Grooving



Wendeschneidplatte

Indexable insert

A315

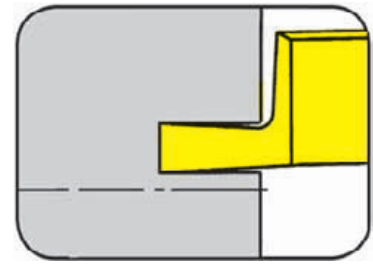

Nutaußen-Ø ab	from outer groove Ø	20 mm
Stechtiefe bis	Depth of groove up to	3 mm
Stechbreite	Width of groove	1,5-3 mm

für Klemhalter
for Toolholder

Typ 356...03-07
Type 357

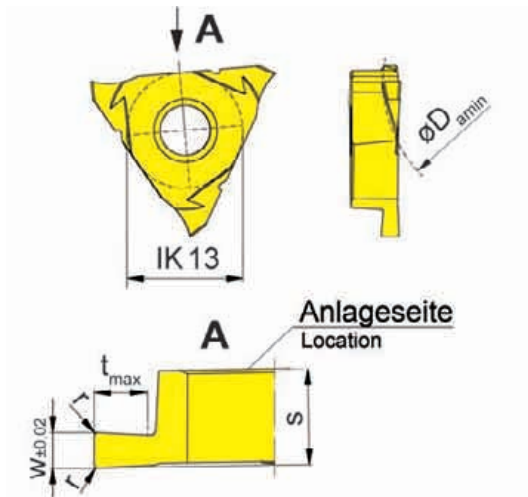

R = rechts wie gezeichnet
R = right hand version shown

L = links spiegelbildlich
L = left hand version

Bestellnummer Part number	w	r	t _{max}	D _{a min}	s	Größe Size	TH35
LA315.2015.02R	1,5	0,2	2	20	5,4	05	▲
RA315.3020.02L	2,0	0,2	3	30	5,4	05	▲
LA315.3030.02R	3,0	0,2	3	30	5,4	05	▲
RA315.2015.02L	1,5	0,2	2	20	5,4	05	▲
LA315.3020.02R	2,0	0,2	3	30	5,4	05	▲
RA315.3030.02L	3,0	0,2	3	30	5,4	05	▲

▲ ab Lager / on stock Δ 4 Wochen / 4 weeks x auf Anfrage / upon request

● empfohlen / recommended

o bedingt einsetzbar / alternative recommendation

- nicht geeignet / not suitable

■ unbeschichtete HM-Sorten / uncoated grades

■ beschichtete HM-Sorten / coated grades

■ bestückt/Cermet / brazed/Cermet

Abmessungen in mm

Dimensions in mm

Ausführung R oder L angeben

State R or L version

P	•
M	•
K	•
N	•
S	•
H	-

HM-Sorten
Carbide grades

Axialeinstechen

Face Grooving



Wendeschneidplatte

Indexable insert

A315

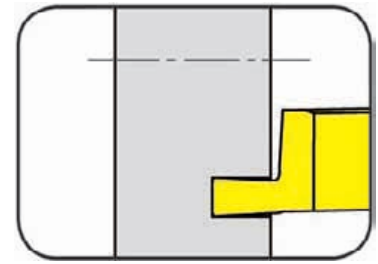

Nutaußen-Ø ab	from outer groove Ø	20 mm
Stechtiefe bis	Depth of groove up to	3 mm
Stechbreite	Width of groove	1,5-3 mm

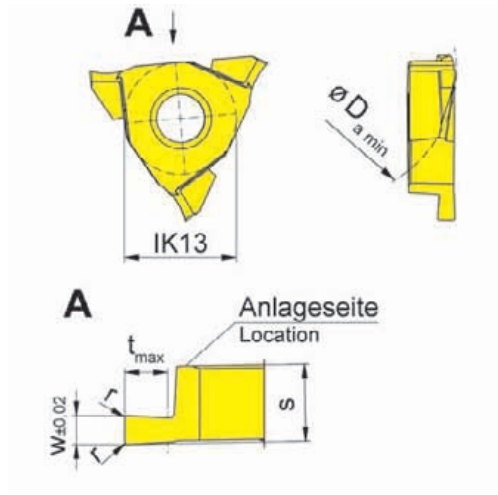

für Klemhalter
for Toolholder

Typ 356
Type 357

R = rechts wie gezeichnet
R = right hand version shown

Wechselgenauigkeit
Länge ± 0,02 mm
Indexability length ± 0,02 mm

Bestellnummer Part number	w	r	t _{max}	D _{a min}	s	Größe Size	TH35
RA315.2015.02R	1,5	0,2	2	20	5,4	05	▲
RA315.3020.02R	2,0	0,2	3	30	5,4	05	▲
RA315.3030.02R	3,0	0,2	3	30	5,4	05	▲

▲ ab Lager / on stock Δ 4 Wochen / 4 weeks x auf Anfrage / upon request

● empfohlen / recommended

o bedingt einsetzbar / alternative recommendation

- nicht geeignet / not suitable

■ unbeschichtete HM-Sorten / uncoated grades

■ beschichtete HM-Sorten / coated grades

■ bestückt/Cermet / brazed/Cermet

Abmessungen in mm

Dimensions in mm

P	•
M	•
K	•
N	•
S	•
H	-

HM-Sorten
Carbide grades



S



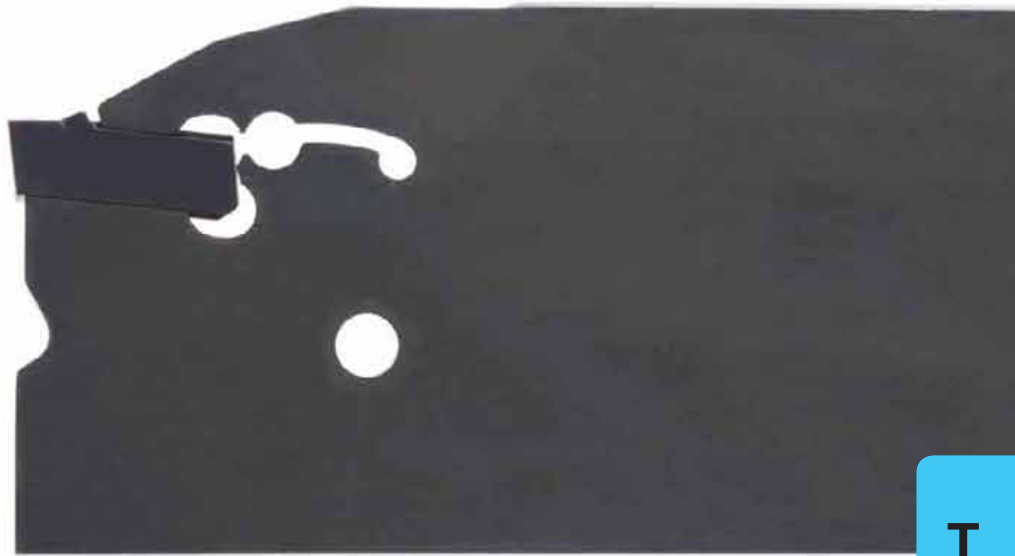

T

System	Seite/page
100	T2
123/S223	T52
224	T62
264	T80
274	T88
229	T104
312	T116
316	T130

Klemmhalter
Toolholder
H100



Seite/Page
T4, T7, T18



Seite/Page
T5



Seite/Page
T6



Seite/Page
T8-T15

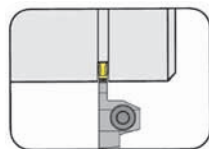

Seite/Page
T16-T17

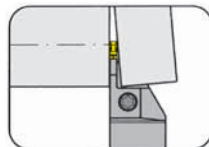

Seite/Page
T19-T34

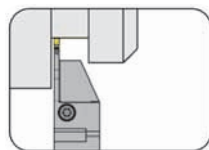

Seite/Page
T35

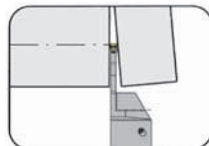

Seite/Page
T46-T47

Kassette
Cassette
NK100

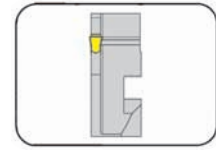

Seite/Page
T36, T38

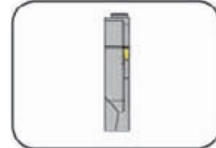

Seite/Page
T48

Grundhalter
Basic toolholder
System220

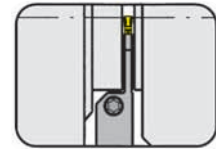

Seite/Page
T37

Schneidplatte
Insert
S100

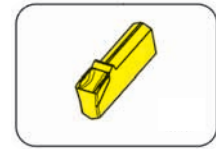

Seite/Page
T39-T45

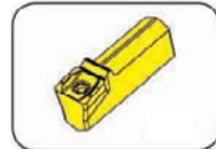

Seite/Page
T49-T50

T

100



T

**Klemmhalter mit
Schneidplatten**

Stechbreite 1,6 - 5,0 mm

Stechtiefe bis 55 mm

**Toolholder with
Inserts**

Width of groove 1,6 - 5,0 mm

Depth of groove up to 55 mm

Klemmhalter

Toolholder

H100

mit Selbstklemmung
with self clamping

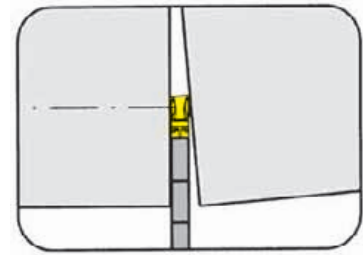

Stechtiefe bis Stechbreite	Depth of groove up to Width of groove	55 mm 2,0 - 5,0 mm
-------------------------------	--	-----------------------

für Schneidplatte
for Insert

Typ S100
Type

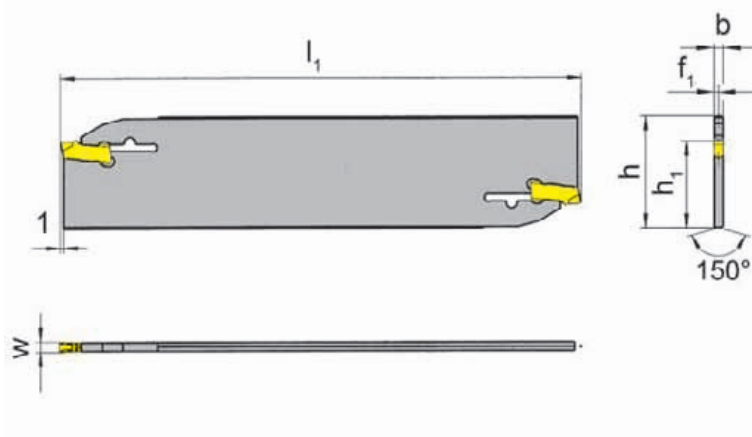

T

Bestellnummer Part number	h	b	l ₁	h ₁	f ₁	t _{max}	Größe Size
H100.2601.01	26	1,5	110	21,4	0,75	25,0	01
H100.2602.02	26	1,9	110	21,4	0,95	37,5	02
H100.2603.03	26	2,3	110	21,4	1,15	37,5	03
H100.2604.04	26	3,1	110	21,8	1,65	40,0	04
H100.3201.01	32	1,5	150	24,8	0,75	25,0	01
H100.3202.02	32	1,9	150	24,8	0,95	50,0	02
H100.3203.03	32	2,3	150	24,8	1,15	50,0	03
H100.3204.04	32	3,1	160	24,8	1,65	55,0	04
H100.3205.05	32	3,9	160	24,8	2,00	55,0	05

Weitere Abmessungen auf Anfrage
Further sizes upon request

w siehe Schneidplatten
w see inserts

Abmessungen in mm
Dimensions in mm

Hinweis:

Der Schlüssel P39L gehört nicht zum Lieferumfang des Schneidenträgers. Bitte separat bestellen!

Note:

Wrench P39L ist not combined with blade - separate order required!

Abstechen

Parting Off



Klemmhalter

Toolholder

H100

mit innerer Kühlmittelzufuhr
with through coolant supply

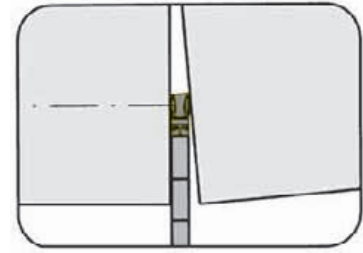

Stechtiefe bis
Stechbreite

Depth of groove up to
Width of groove

60 mm
2,5 - 4,0 mm

für Schneidplatte
for Insert

Typ S100
Type S100...IK

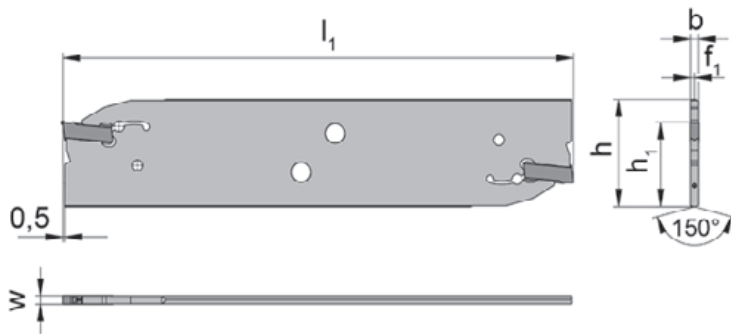

Bestellnummer Part number	h	b	l ₁	h ₁	f ₁	t _{max}	Größe Size
H100.2602.8.02.IK	26	1,9	110	21,4	0,95	35	02
H100.2603.8.03.IK	26	2,3	110	21,4	1,15	35	03
H100.2604.8.04.IK	26	3,1	110	21,4	1,55	35	04
H100.3202.8.02.IK	32	1,9	150	24,8	0,95	55	02
H100.3203.8.03.IK	32	2,3	150	24,8	1,15	60	03
H100.3204.8.04.IK	32	3,1	150	24,8	1,55	60	04

Weitere Abmessungen auf Anfrage
Further sizes upon request

Abmessungen in mm
Dimensions in mm

Der Schlüssel **P101.02** gehört nicht zum Lieferumfang des Halters. Bitte separat bestellen!
Wrench **P101.02** is not combined with tool holder - separate order required!

Ersatzteile

Spare Parts

Klemmhalter Toolholder	Inbus-Schlüssel Wrench	IK-Verschluss Coolant plug
H100...	SW3,0 DIN911	020.IK01.5732

T

Einstechen und Abstechen

Grooving and Parting Off



Klemmhalter

Toolholder

H100

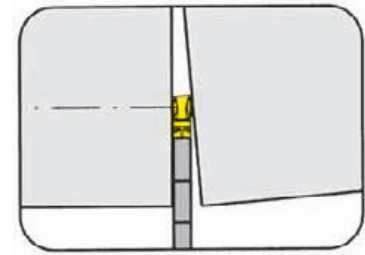

Stechtiefe bis Stechbreite	Depth of groove up to Width of groove	25 mm 2,0 - 2,5 mm
-------------------------------	--	-----------------------

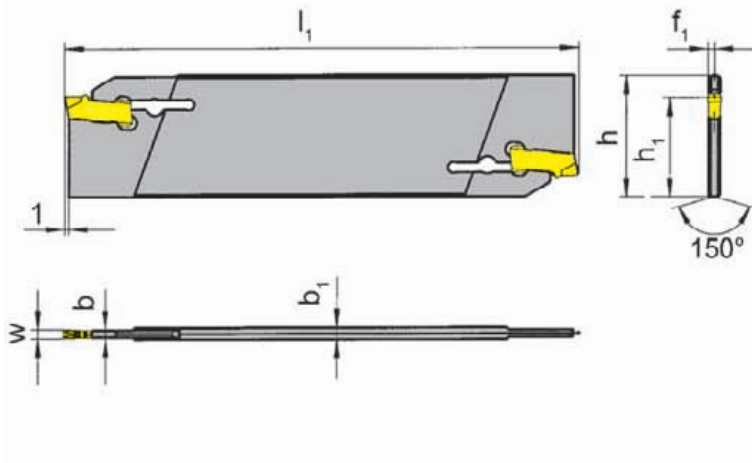

für Schneidplatte
for Insert

Typ S100
Type

T

Bestellnummer Part number	h	b	l ₁	h ₁	f ₁	t _{max}	b ₁	Größe Size
H100.2603.01	26	1,5	110	21,4	1,15	21	2,3	01
H100.2603.02	26	1,9	110	21,4	1,15	21	2,3	02
H100.3203.01	32	1,5	150	24,8	1,15	25	2,3	01
H100.3203.02	32	1,9	150	24,8	1,15	25	2,3	02

Weitere Abmessungen auf Anfrage
Further sizes upon request

Abmessungen in mm
Dimensions in mm

Der Schlüssel P39L gehört nicht zum Lieferumfang des Schneidenträgers. Bitte separat bestellen!
Wrench P39L is not combined with blade - separate order required!

Einstecken und Abstechen

Grooving and Parting Off



Klemmhalter

Toolholder

H100

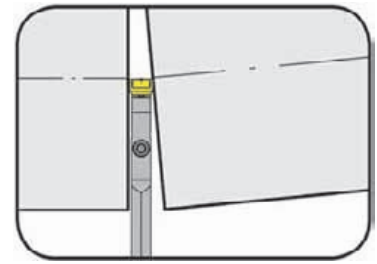

Stechbreite	Width of groove	8,0 - 12,0 mm
-------------	-----------------	---------------

für Schneidplatte
for Insert

Typ S100
Type

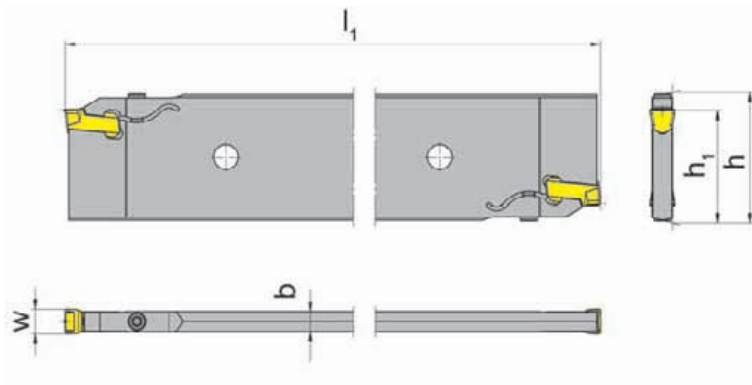

Bestellnummer Part number	h	b	l ₁	h ₁	Schneidbreite Width of groove
H100.5208.26.08	52,6	7,4	260	45	8
H100.5210.26.10	52,6	8,2	260	45	10
H100.5212.26.12	52,6	10,4	260	45	12

Weitere Abmessungen auf Anfrage
Further sizes upon request

Abmessungen in mm
Dimensions in mm

Das Anzugsdrehmoment der Schrauben finden Sie in den Technischen Hinweisen.
For torque specification of the screw, please see Technical Instructions.

Ersatzteile

Spare Parts

Klemmhalter Toolholder	Spannschraube Screw	TORX PLUS®-Schlüssel TORX PLUS® Wrench
H100...	5.13 T20P	T20PQ



Einstechen und Abstechen

Grooving and Parting Off



Klemmhalter

Toolholder

H100

mit Selbstklemmung
with self clamping

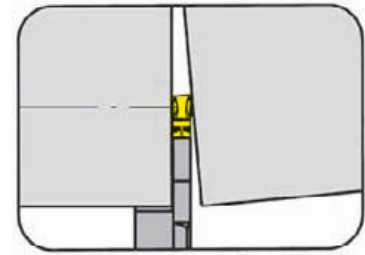

Stechtiefe bis Stechbreite	Depth of groove up to Width of groove	34 mm 2,0 - 4,0 mm
-------------------------------	--	-----------------------

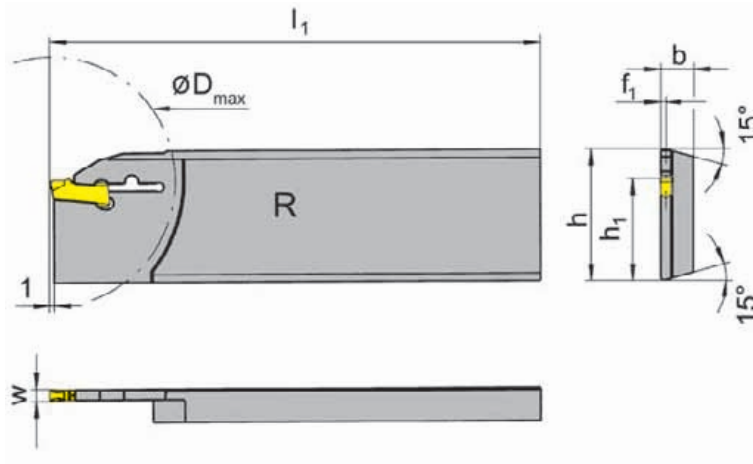

für Schneidplatte
for Insert

Typ S100
Type

R = rechts wie gezeichnet
R = right hand version shown

L = links spiegelbildlich
L = left hand version

Bestellnummer Part number	h	b	l ₁	h ₁	f ₁	t _{max}	D _{max}	Größe Size
R/LH100.2608.31	26	7,9	110	21,4	0,75	21	42	01
R/LH100.2608.32	26	7,9	110	21,4	0,95	25	50	02
R/LH100.2608.33	26	7,9	110	21,4	1,15	25	50	03
R/LH100.2608.34	26	7,9	110	21,4	1,55	25	50	04
R/LH100.3208.31	32	7,9	112	24,8	0,75	25	50	01
R/LH100.3208.32	32	7,9	112	24,8	0,95	34	68	02
R/LH100.3208.33	32	7,9	112	24,8	1,15	34	68	03
R/LH100.3208.34	32	7,9	112	24,8	1,55	34	68	04

Ausführung R oder L angeben
State R or L version

w siehe Schneidplatten
w see inserts

Abmessungen in mm
Dimensions in mm

Weitere Abmessungen auf Anfrage
Further sizes upon request

Hinweis:

Der Schlüssel P39L gehört nicht zum Lieferumfang des Schneidenträgers. Bitte separat bestellen!

Note:

Wrench P39L ist not combined with blade - separate order required!

Empfohlen auf Maschinen der Firma Traub Typ:
Recommended for Traub machines type:

R/L100.2608.31-34

R/LH100.3208.31-34

TNC 30
TNM 28
TNS 26
TNS 30/42
TNA 300
TNK 28/36
TNL 26

TNC 42/65
TNM 42/65
TNS 65
TNS 60
TNA 400
TNA 300

Einstechen und Abstechen

Grooving and Parting Off



Klemmhalter

Toolholder

H100

mit Selbstklemmung
with self clamping

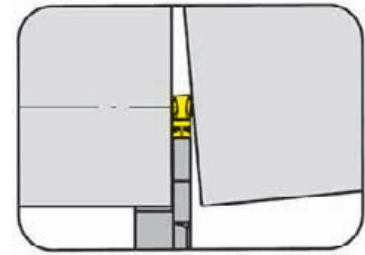

Stechtiefe bis Stechbreite	Depth of groove up to Width of groove	34 mm 2,0 - 4,0 mm
-------------------------------	--	-----------------------

für Schneidplatte
for insert

Typ S100
Type

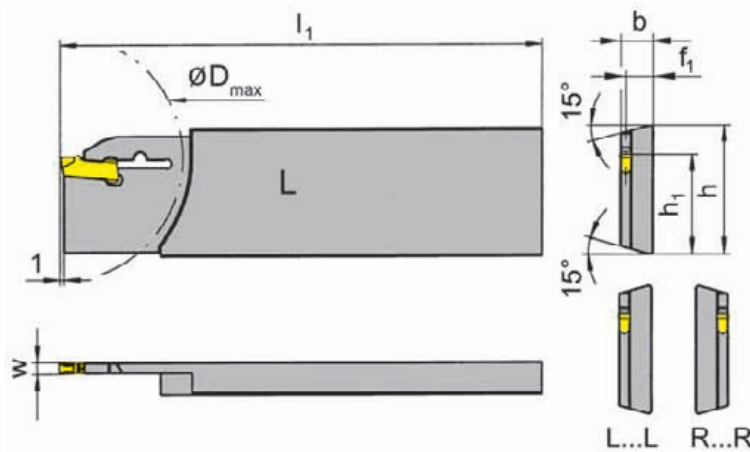

L = links wie gezeichnet
L = left hand version shown

R = rechts spiegelbildlich
R = right hand version

Bestellnummer Part number	h	b	l ₁	h ₁	f ₁	t _{max}	D _{max}	Größe Size
LH100.2608.31L	26	7,9	110	21,4	7,15	21	42	01
RH100.2608.31R	26	7,9	110	21,4	7,15	21	42	01
LH100.3208.31L	32	7,9	112	24,8	7,15	25	50	01
RH100.3208.31R	32	7,9	112	24,8	7,15	25	50	01
LH100.2608.32L	26	7,9	110	21,4	6,95	25	50	02
RH100.2608.32R	26	7,9	110	21,4	6,95	25	50	02
LH100.3208.32L	32	7,9	112	24,8	6,95	34	68	02
RH100.3208.32R	32	7,9	112	24,8	6,95	34	68	02
LH100.2608.33L	26	7,9	110	21,4	6,75	25	50	03
RH100.2608.33R	26	7,9	110	21,4	6,75	25	50	03
LH100.3208.33L	32	7,9	112	24,8	6,75	34	68	03
RH100.3208.33R	32	7,9	112	24,8	6,75	34	68	03
LH100.2608.34L	26	7,9	110	21,4	6,35	25	50	04
RH100.2608.34R	26	7,9	110	21,4	6,35	25	50	04
LH100.3208.34L	32	7,9	112	24,8	6,35	34	68	04
RH100.3208.34R	32	7,9	112	24,8	6,35	34	68	04

Ausführung R oder L angeben
State R or L version

w siehe Schneidplatten
w see inserts

Abmessungen in mm
Dimensions in mm

Weitere Abmessungen auf Anfrage
Further sizes upon request

Hinweis:

Der Schlüssel P39L gehört nicht zum Lieferumfang des Schneidenträgers. Bitte separat bestellen!

Note:

Wrench P39L ist not combined with blade - separate order required!

T

Einstechen und Abstechen

Grooving and Parting Off



Klemmhalter

Toolholder

H100

mit Selbstklemmung
with self clamping

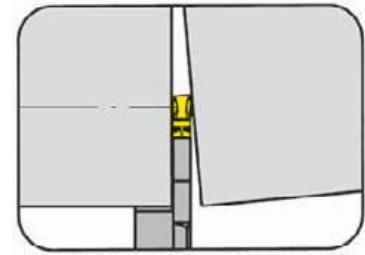

Stechtiefe bis Stechbreite	Depth of groove up to Width of groove	41 mm 4 mm
-------------------------------	--	---------------

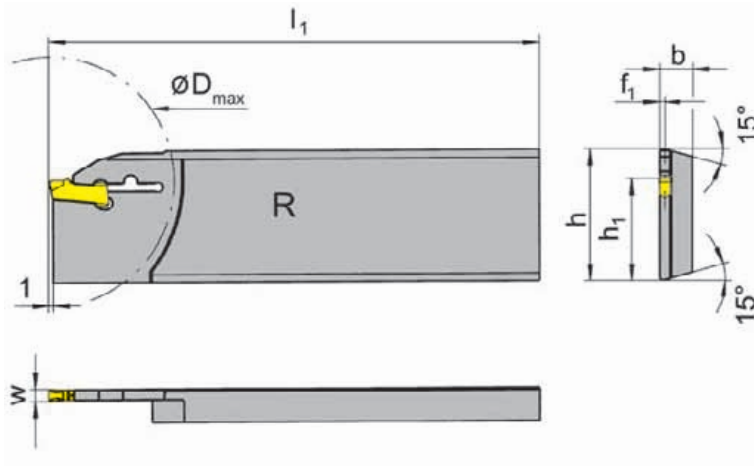

für Schneidplatte
for Insert

Typ S100
Type

T

R = Rechtsausführung
R = right hand version

Bestellnummer Part number	h	b	l ₁	h ₁	f ₁	t _{max}	D _{max}	Größe Size
RH100.3208.2.44	32	7,9	160	24,8	1,55	41	80	04
RH100.3208.44	32	7,9	130	24,8	1,55	41	80	04

Weitere Abmessungen auf Anfrage
Further sizes upon request

w siehe Schneidplatten
w see inserts

Abmessungen in mm
Dimensions in mm

Hinweis:

Der Schlüssel P39L gehört nicht zum Lieferumfang des Schneidträgers. Bitte separat bestellen!

Note:

Wrench P39L ist not combined with blade - separate order required!

Einstechen und Abstechen

Grooving and Parting Off



Klemmhalter

Toolholder

H100

mit Schraubklemmung
with screwed clamping

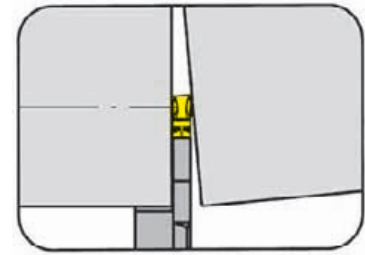

Stechtiefe bis Stechbreite	Depth of groove up to Width of groove	32,5 mm 2 - 3 mm
-------------------------------	--	---------------------

für Schneidplatte
for Insert

Typ S100
Type

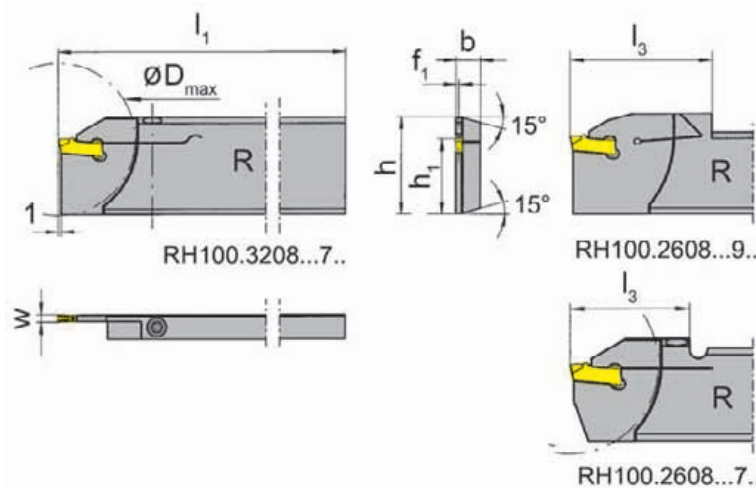

R = rechts wie gezeichnet
R = right hand version shown

L = links spiegelbildlich
L = left hand version

Bestellnummer Part number	h	b	l ₁	h ₁	f ₁	l ₃	t _{max}	D _{max}	Größe Size
R/LH100.2608.71	26	7,9	110	21,4	0,75	33,8	25,0	50	01
R/LH100.3208.71	32	7,9	112	24,8	0,75	33,8	25,0	50	01
R/LH100.2608.72	26	7,9	110	21,4	0,95	33,8	25,0	50	02
R/LH100.3208.72	32	7,9	112	24,8	0,95	33,8	25,0	50	02
R/LH100.2608.93	26	8,0	112	21,4	1,15	40,0	25,0	50	03
R/LH100.3208.93	32	8,0	112	24,8	1,15	40,0	32,5	65	03

Ausführung R oder L angeben
State R or L version

w siehe Schneidplatten
w see inserts

Abmessungen in mm
Dimensions in mm

Weitere Abmessungen auf Anfrage
Further sizes upon request

Das Anzugsdrehmoment der Schrauben finden Sie in den Technischen Hinweisen.
For torque specification of the screw, please see Technical Instructions.

Ersatzteile

Spare Parts

Klemmhalter Toolholder	Spannschraube Screw	TORX PLUS®-Schlüssel TORX PLUS® Wrench
R/LH100...	4.15T15P	T15PQ
R/LH100...93	030.0413.T15P	T15PQ

Einstechen und Abstechen

Grooving and Parting Off



Klemmhalter

Toolholder

H100

mit Schraubklemmung
with screwed clamping

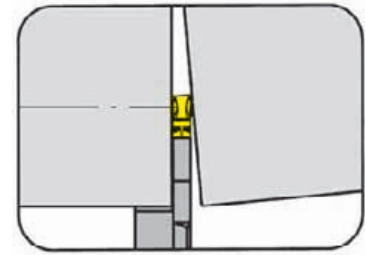

Stechtiefe bis	Depth of groove up to	32,5 mm
Stechbreite	Width of groove	2 - 3 mm

für Schneidplatte
for insert

Typ S100
Type

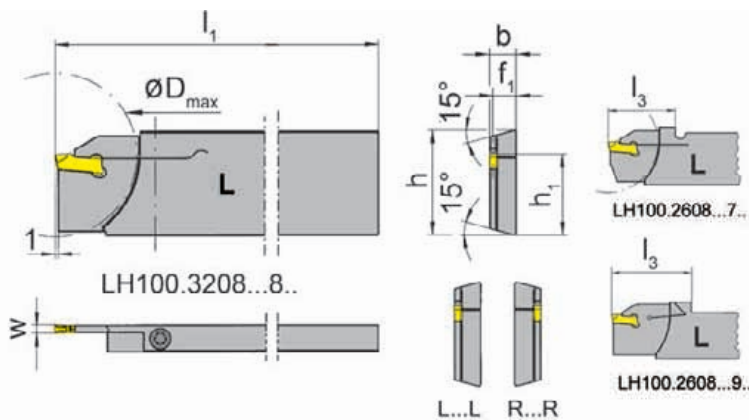

L = links wie gezeichnet
L = left hand version shown

R = rechts spiegelbildlich
R = right hand version

Bestellnummer Part number	h	b	l_1	h_1	f_1	l_3	t_{max}	D_{max}	Größe Size
LH100.2608.71L	26	7,9	110	21,4	7,15	33,8	25,0	50	01
LH100.3208.71L	32	7,9	112	24,8	7,15	33,8	25,0	50	01
RH100.2608.71R	26	7,9	110	21,4	7,15	33,8	25,0	50	01
RH100.3208.71R	32	7,9	112	24,8	7,15	33,8	25,0	50	01
LH100.2608.72L	26	7,9	110	21,4	6,95	33,8	25,0	50	02
LH100.3208.72L	32	7,9	112	24,8	6,95	33,8	25,0	50	02
RH100.2608.72R	26	7,9	110	21,4	6,95	33,8	25,0	50	02
RH100.3208.72R	32	7,9	112	24,8	6,95	33,8	25,0	50	02
LH100.2608.93L	26	8,0	115	21,4	6,85	40,0	25,0	50	03
LH100.3208.93L	32	8,0	115	24,8	6,85	42,0	32,5	65	03
RH100.2608.93R	26	8,0	115	21,4	6,85	40,0	25,0	50	03
RH100.3208.93R	32	8,0	115	24,8	6,85	42,0	32,5	65	03

Ausführung R oder L angeben
State R or L version

w siehe Schneidplatten
w see inserts

Abmessungen in mm
Dimensions in mm

Weitere Abmessungen auf Anfrage
Further sizes upon request

Das Anzugsdrehmoment der Schrauben finden Sie in den Technischen Hinweisen.
For torque specification of the screw, please see Technical Instructions.

Ersatzteile

Spare Parts

Klemmhalter Toolholder	Spannschraube Screw	TORX PLUS®-Schlüssel TORX PLUS® Wrench	Stift Pin
R/LH100...	4.15T15P	T15PQ	
R/LH100...93R/L	030.0413.T15P	T15PQ	020.0040.0999

Einstechen und Abstechen

Grooving and Parting Off



Klemmhalter

Toolholder

H100

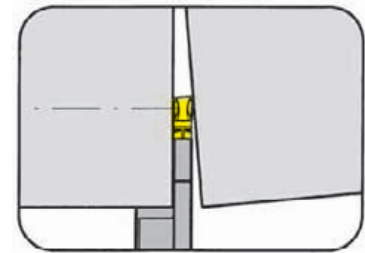

Stechtiefe bis	Depth of groove up to	32,5 mm
Stechbreite	Width of groove	3 - 4 mm

für TRAUB-Maschinen (TNX65)
for machines TRAUB (TNX65)

für Schneidplatte
for Insert

Typ S100
Type

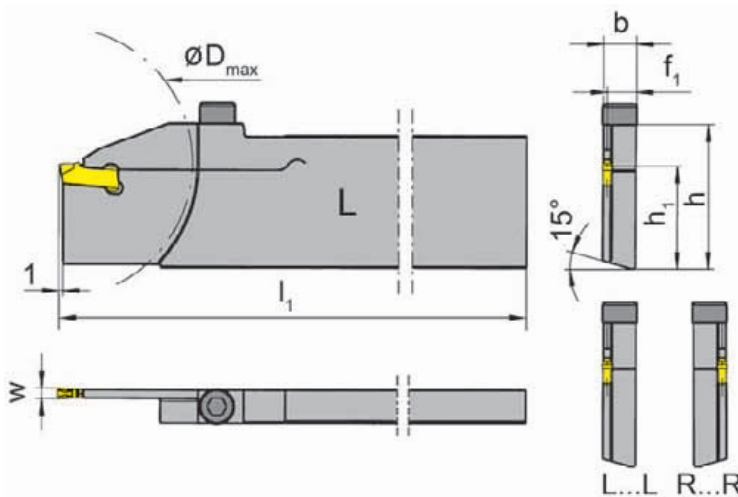

L = links wie gezeichnet
L = left hand version shown

R = rechts spiegelbildlich
R = right hand version

Bestellnummer Part number	h	b	l ₁	h ₁	f ₁	t _{max}	D _{max}	Größe Size
LH100.3280.73L	32	7,9	130	24,8	6,75	32,5	65	03
RH100.3280.73R	32	7,9	130	24,8	6,75	32,5	65	03
LH100.3280.74L	32	7,9	130	24,8	6,35	32,5	65	04
RH100.3280.74R	32	7,9	130	24,8	6,35	32,5	65	04

Ausführung R oder L angeben
State R or L version

w siehe Schneidplatten
w see inserts

Abmessungen in mm
Dimensions in mm

Weitere Abmessungen auf Anfrage
Further sizes upon request

Das Anzugsdrehmoment der Schrauben finden Sie in den Technischen Hinweisen.
For torque specification of the screw, please see Technical Instructions.

Ersatzteile

Spare Parts

Klemmhalter Toolholder	Inbus-Schlüssel Wrench
LH100...	SW4,0 DIN911

T

Einstechen und Abstechen

Grooving and Parting Off



Klemmhalter

Toolholder

H100

mit Schraubklemmung
with screwed clamping

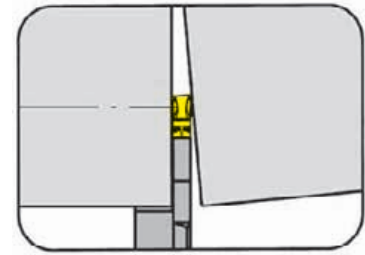

Stechtiefe bis Stechbreite	Depth of groove up to Width of groove	33,5 mm 3 - 4 mm
-------------------------------	--	---------------------

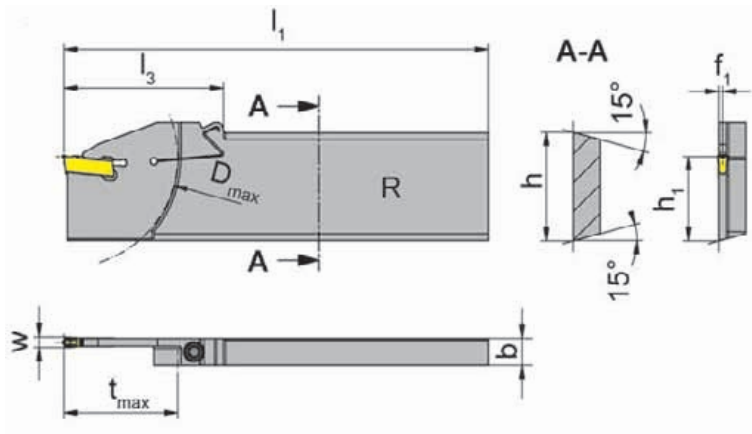

für Schneidplatte
for Insert

Typ S100
Type

für TRAUB- und INDEX-
Maschinen
for machines TRAUB and
INDEX

R = rechts wie gezeichnet
R = right hand version shown

L = links spiegelbildlich
L = left hand version

Bestellnummer Part number	h	b	l ₁	h ₁	f ₁	l ₃	t _{max}	D _{max}	Maschinentyp Machine type	Größe Size
R/LH100.3208.83	32	8	125	24,8	1,15	47	33,5	65	TraubTNX65/42, IndexC65	03
LH100.3208.15.83	32	8	150	24,8	1,15	47	33,5	65	TraubTNX65/42, IndexC65	03
R/LH100.3208.84	32	8	125	24,8	1,50	47	33,5	65	TraubTNX65/42, IndexC65	04
LH100.3208.15.84	32	8	150	24,8	1,15	47	33,5	65	TraubTNX65/42, IndexC65	04

Ausführung R oder L angeben
State R or L version

w siehe Schneidplatten
w see inserts

Abmessungen in mm
Dimensions in mm

Weitere Abmessungen auf Anfrage
Further sizes upon request

Das Anzugsdrehmoment der Schrauben finden Sie in den Technischen Hinweisen.
For torque specification of the screw, please see Technical Instructions.

Ersatzteile

Spare Parts

Klemmhalter Toolholder	Spannschraube Screw	TORX PLUS®-Schlüssel TORX PLUS® Wrench
R/LH100...	030.505P.0718	T15PQ

Einstechen und Abstechen

Grooving and Parting Off



Klemmhalter

Toolholder

H100

mit Schraubklemmung
with screwed clamping

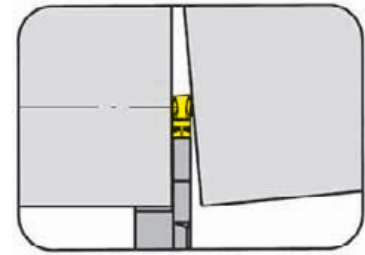

Stechtiefe bis Stechbreite	Depth of groove up to Width of groove	41 mm 3 - 4 mm
-------------------------------	--	-------------------

für Schneidplatte
for Insert

Typ S100
Type

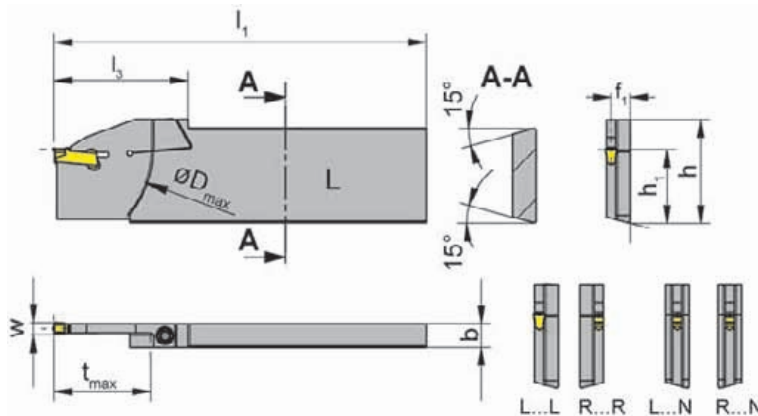

L = links wie gezeichnet
L = left hand version shown

R = rechts spiegelbildlich
R = right hand version

für TRAUB- und INDEX-
Maschinen
for machines TRAUB and
INDEX

Bestellnummer Part number	h	b	l ₁	h ₁	f ₁	l ₃	t _{max}	D _{max}	Maschinentyp Machine type	Größe Size
LH100.3208.83L	32	8	125	24,8	6,75	47,0	33,5	65	TraubTNX65/42, IndexC65	03
RH100.3208.83R	32	8	125	24,8	6,75	47,0	33,5	65	TraubTNX65/42, IndexC65	03
R/LH100.3208.83N	32	8	125	24,8	4,00	47,0	33,5	65	TraubTNX65/42, IndexC65	03
LH100.3208.84L	32	8	125	24,8	6,35	47,0	33,5	65	TraubTNX65/42, IndexC65	04
RH100.3208.84R	32	8	125	24,8	6,35	47,0	33,5	65	TraubTNX65/42, IndexC65	04
R/LH100.3208.84N	32	8	134	24,8	4,00	54,5	41,0	80	TraubTNX80/65	04

Ausführung R oder L angeben
State R or L version

w siehe Schneidplatten
w see inserts

Abmessungen in mm
Dimensions in mm

Weitere Abmessungen auf Anfrage
Further sizes upon request

Das Anzugsdrehmoment der Schrauben finden Sie in den Technischen Hinweisen.
For torque specification of the screw, please see Technical Instructions.

Ersatzteile

Spare Parts

Klemmhalter Toolholder	Spannschraube Screw	TORX PLUS®-Schlüssel TORX PLUS® Wrench
R/LH100...	030.505P.0718	T15PQ

Einstechen und Abstechen

Grooving and Parting Off



Klemmhalter

Toolholder

H100

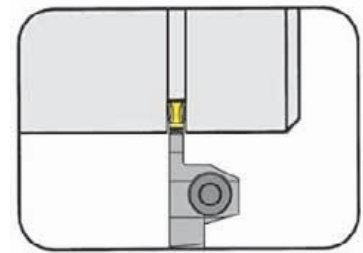

Stechtiefe bis Stechbreite	Depth of groove up to Width of groove	10 mm 3 mm
-------------------------------	--	---------------

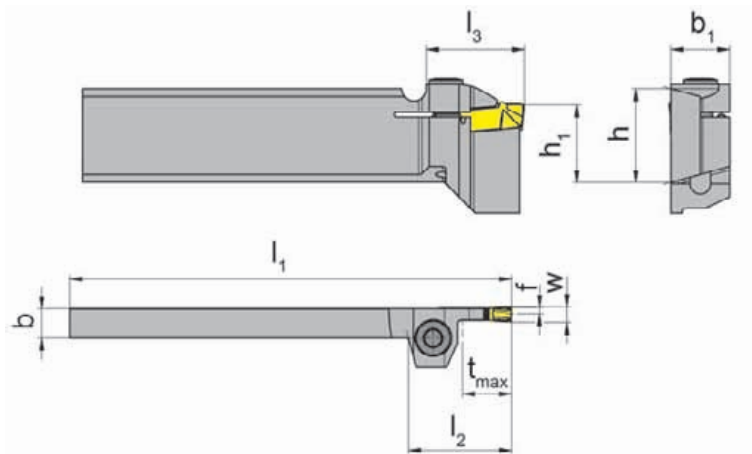

für Schneidplatte
for Insert

Typ S100
Type

für REIKA Maschinen
for machines REIKA

L = links wie gezeichnet
L = left hand version shown

Bestellnummer Part number	h	b	l ₁	h ₁	l ₂	f	l ₃	t _{max}	b ₁	Größe Size
LH100.1908.R.13	19	8	90	15,7	16	1,15	20	10	12	03
LH100.3208.R.13	32	8	110	24,8	16	1,15	20	10	12	03

Weitere Abmessungen auf Anfrage
Further sizes upon request

w siehe Schneidplatten
w see inserts

Abmessungen in mm
Dimensions in mm

Das Anzugsdrehmoment der Schrauben finden Sie in den Technischen Hinweisen.
For torque specification of the screw, please see Technical Instructions.

Ersatzteile

Spare Parts

Klemmhalter Toolholder	Spannschraube Screw	TORX PLUS®-Schlüssel TORX PLUS® Wrench
LH100...R.13	5.17T20P	T20PQ

Einstechen und Abstechen

Grooving and Parting Off



Klemmhalter

Toolholder

H100

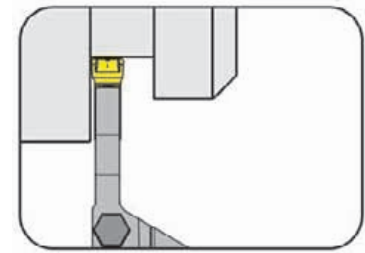

Stechtiefe bis
Stechbreite

Depth of groove up to
Width of groove

65 mm
8 - 12 mm

für Schneidplatte
for Insert

Typ S100
Type

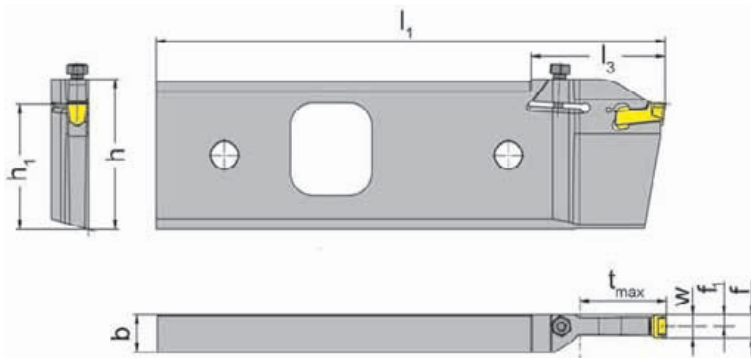

für REIKA Maschinen
for machines REIKA

L = links wie gezeichnet
L = left hand version shown

Bestellnummer Part number	h	b	l_1	h_1	f_1	l_3	f	t_{max}	Größe Size
LH100.5517.38.8.08	65	16,4	224	55	4	59	$f_1+w/2$	38	08
LH100.5517.54.8.08	65	16,4	224	55	4	75	$f_1+w/2$	54	08
LH100.5517.38.8.10	65	16,4	224	55	5	59	$f_1+w/2$	38	10
LH100.5517.54.8.10	65	16,4	224	55	5	75	$f_1+w/2$	54	10
LH100.5517.44.8.12	65	16,4	224	55	6	65	$f_1+w/2$	44	12
LH100.5517.65.8.12	65	16,4	224	55	6	86	$f_1+w/2$	65	12

Weitere Abmessungen auf Anfrage
Further sizes upon request

Abmessungen in mm
Dimensions in mm

Das Anzugsdrehmoment der Schrauben finden Sie in den Technischen Hinweisen.
For torque specification of the screw, please see Technical Instructions.

Ersatzteile

Spare Parts

Klemmhalter Toolholder	Spannschraube Screw	TORX PLUS®-Schlüssel TORX PLUS® Wrench
LH100...	030.6075.T20P	T20PQ

Einstechen und Abstechen

Grooving and Parting Off



Klemmhalter

Toolholder

H100

mit Selbstklemmung
with self clamping

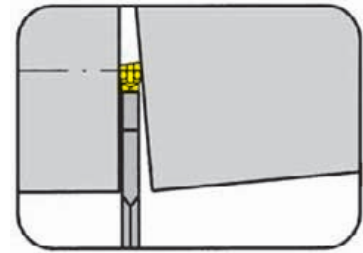

Stechtiefe bis Stechbreite	Depth of groove up to Width of groove	38 mm 2 - 3 mm
-------------------------------	--	-------------------

für Schneidplatte
for Insert

Typ S100
Type

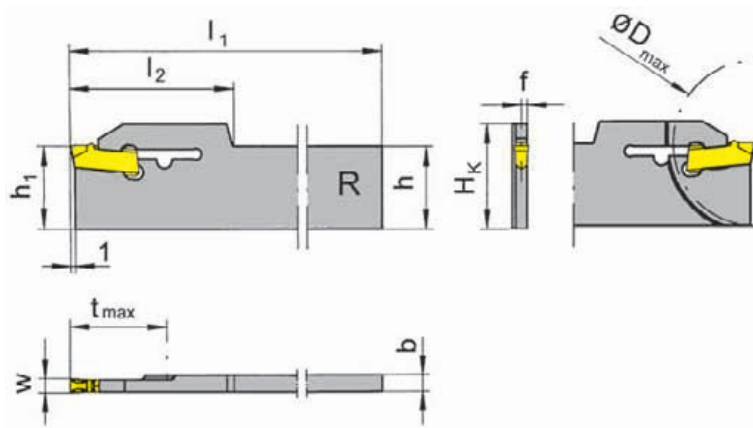

R = Rechtsausführung
R = right hand version

Bestellnummer Part number	H _k	b	l ₁	h ₁	f	l ₂	t _{max}	D _{max}	h	Größe Size
RH100.1703.21	22,1	3,2	110	17,4	0,75	32,0	17,5	35	17,4	01
RH100.2203.21	26,9	3,2	150	22,2	0,75	32,0	38,0	50	22,1	01
RH100.1703.33	22,1	3,2	110	17,4	1,15	34,5	30,0	60	17,4	03
RH100.2203.33	26,9	3,2	150	22,2	1,15	34,5	38,0	76	22,1	03

Weitere Abmessungen auf Anfrage
Further sizes upon request

w siehe Schneidplatten
w see inserts

Abmessungen in mm
Dimensions in mm

Hinweis:

Der Schlüssel **P39L** gehört nicht zum Lieferumfang des Schneidträgers R/LH100...33. Bitte separat bestellen!

Note:

Wrench **P39L** ist not combined with blade R/LH100...33 - separate order required!

Einstechen und Abstechen

Grooving and Parting Off



Klemmhalter

Toolholder

H100

mit Schraubklemmung
with screwed clamping

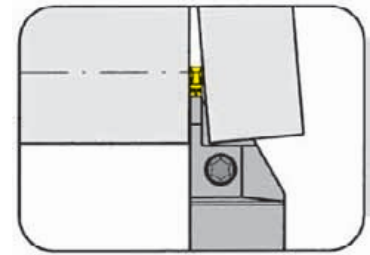

Stechtiefe bis Stechbreite	Depth of groove up to Width of groove	21 mm 2,0 mm
-------------------------------	--	-----------------

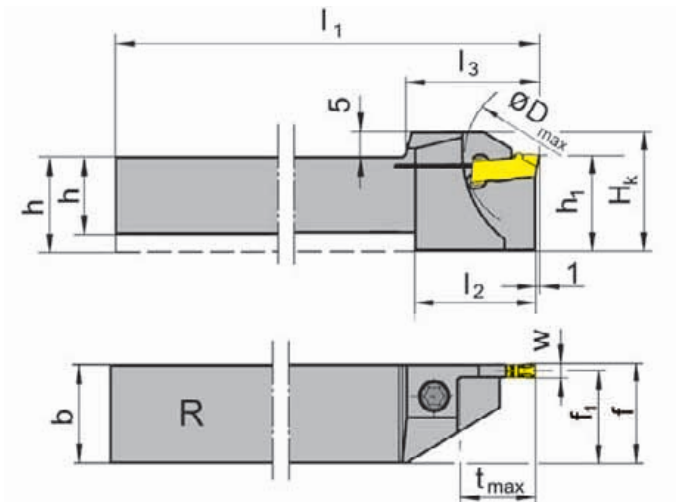

für Schneidplatte
for Insert

Typ S100
Type

R = rechts wie gezeichnet
R = right hand version shown

L = links spiegelbildlich
L = left hand version

Bestellnummer Part number	h	b	l ₁	l ₂	l ₃	h ₁	f ₁	f	t _{max}	D _{max}	H _K	Größe Size
R/LH100.1010.01	10	10	125	19	21,0	13	9,25	f ₁ +w/2	10,5	21	18	01
R/LH100.1010.11	10	10	125	21	23,0	16	9,25	f ₁ +w/2	13,0	42	21	01
R/LH100.1212.01	12	12	125	21	23,0	16	11,25	f ₁ +w/2	13,0	26	21	01
R/LH100.1212.11	12	12	125	21	26,0	16	11,25	f ₁ +w/2	16,0	42	21	01
R/LH100.1616.11	16	16	125	24	26,0	20	15,25	f ₁ +w/2	16,0	42	25	01
R/LH100.1616.21	16	16	125	30	33,5	20	15,25	f ₁ +w/2	21,0	42	25	01
R/LH100.2020.11	20	20	125	-	33,5	20	19,25	f ₁ +w/2	16,0	42	25	01
R/LH100.2020.21	20	20	125	-	33,5	20	19,25	f ₁ +w/2	21,0	42	25	01
R/LH100.2525.21	25	25	150	-	33,5	25	24,30	f ₁ +w/2	21,0	42	30	01

Ausführung R oder L angeben
State R or L version

w siehe Schneidplatten
w see inserts

Abmessungen in mm
Dimensions in mm

Weitere Abmessungen auf Anfrage
Further sizes upon request

Das Anzugsdrehmoment der Schrauben finden Sie in den Technischen Hinweisen.
For torque specification of the screw, please see Technical Instructions.

Ersatzteile

Spare Parts

Klemmhalter Toolholder	Spannschraube Screw	TORX PLUS®-Schlüssel TORX PLUS® Wrench
R/LH100...	4.15T15P	T15PQ



Einstechen und Abstechen

Grooving and Parting Off



Klemmhalter

Toolholder

H100

mit Schraubklemmung
with screwed clamping

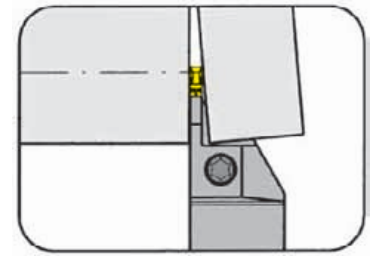

Stechtiefe bis Stechbreite	Depth of groove up to Width of groove	21 mm 2,0 mm
-------------------------------	--	-----------------

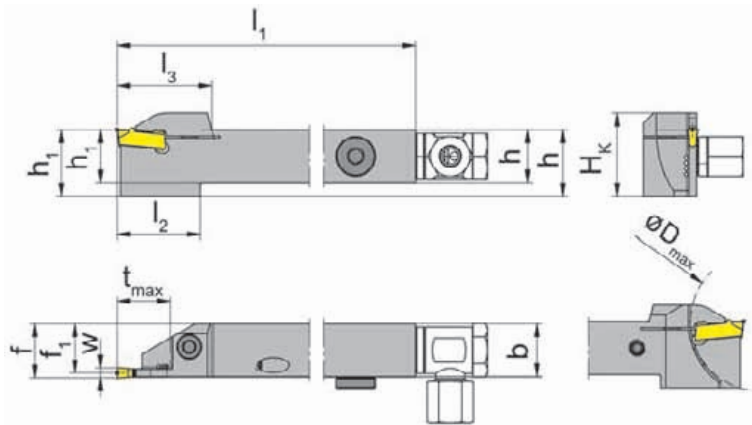

für Schneidplatte
for insert

Typ S100
Type

mit innerer
Kühlmittelzufuhr
with through coolant supply

R = rechts wie gezeichnet
R = right hand version shown

L = links spiegelbildlich
L = left hand version

Bestellnummer Part number	h	b	l ₁	l ₂	l ₃	h ₁	f ₁	f	t _{max}	D _{max}	H _k	Größe Size
R/LH100.1212.01.IK	12	12	125	21	23,0	12	11,25	f ₁ +w/2	13	26	21	01
R/LH100.1212.11.IK	12	12	125	21	26,0	12	11,25	f ₁ +w/2	16	42	21	01
R/LH100.1616.11.IK	16	16	125	24	26,0	16	15,25	f ₁ +w/2	16	42	25	01
R/LH100.1616.21.IK	16	16	125	30	33,5	16	15,25	f ₁ +w/2	21	42	25	01
R/LH100.2020.11.IK	20	20	125	-	33,5	20	19,25	f ₁ +w/2	16	42	25	01
R/LH100.2020.21.IK	20	20	125	-	33,5	20	19,25	f ₁ +w/2	21	42	25	01
R/LH100.2525.21.IK	25	25	150	-	33,5	25	24,30	f ₁ +w/2	21	42	30	01

Ausführung R oder L angeben
State R or L version

w siehe Schneidplatten
w see inserts

Abmessungen in mm
Dimensions in mm

Weitere Abmessungen auf Anfrage
Further sizes upon request

Das Anzugsdrehmoment der Schrauben finden Sie in den Technischen Hinweisen.
For torque specification of the screw, please see Technical Instructions.

Ersatzteile

Spare Parts

Klemmhalter Toolholder	Spannschraube Screw	Kühlmittelanschluss Coolant supply	TORX PLUS®-Schlüssel TORX PLUS® Wrench	Dichtstopfen Sealing plug
R/LH100.1212...	4.15T15P	004.00.61	T15PQ	
R/LH100...	4.15T15P	004.00.16	T15PQ	004.00.26

Einstechen und Abstechen

Grooving and Parting Off



Klemmhalter

Toolholder

H100

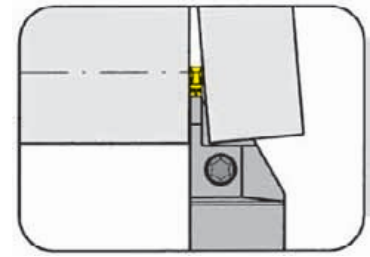

Stechtiefe bis Stechbreite	Depth of groove up to Width of groove	32,5 mm 2,5 mm
-------------------------------	--	-------------------

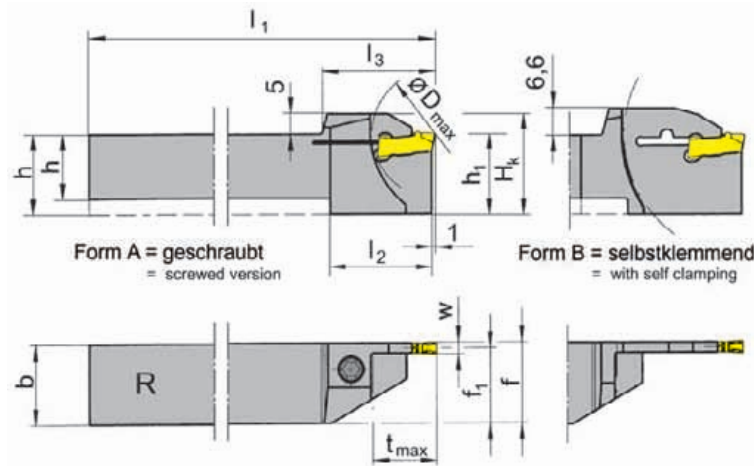

für Schneidplatte
for Insert

Typ S100
Type

R = rechts wie gezeichnet
R = right hand version shown

L = links spiegelbildlich
L = left hand version

Bestellnummer Part number	h	b	l ₁	l ₂	l ₃	h ₁	f ₁	f	t _{max}	D _{max}	H _K	Form Form	Größe Size
R/LH100.1212.02	12	12	125	21	23,0	16	11,05	f ₁ +w/2	13,0	25	21,0	A	02
R/LH100.1212.12	12	12	125	24	26,0	16	11,05	f ₁ +w/2	16,0	42	25,0	A	02
R/LH100.1616.02	16	16	125	19	21,0	20	15,05	f ₁ +w/2	10,5	42	25,0	A	02
R/LH100.1616.12	16	16	125	24	26,0	20	15,05	f ₁ +w/2	16,0	42	25,0	A	02
R/LH100.1616.22	16	16	125	30	33,5	20	15,05	f ₁ +w/2	21,0	42	25,0	A	02
R/LH100.2020.12	20	20	125	-	26,0	20	19,05	f ₁ +w/2	16,0	42	25,0	A	02
R/LH100.2020.22	20	20	125	-	33,5	20	19,05	f ₁ +w/2	21,0	42	25,0	A	02
R/LH100.2020.32	20	20	125	35	38,5	25	19,05	f ₁ +w/2	32,5	65	31,6	B	02
R/LH100.2525.22	25	25	150	-	33,5	25	24,05	f ₁ +w/2	21,0	42	30,0	A	02

Ausführung R oder L angeben
State R or L version

w siehe Schneidplatten
w see inserts

Abmessungen in mm
Dimensions in mm

Weitere Abmessungen auf Anfrage
Further sizes upon request

Bestellhinweis:

Der Schlüssel **P39L** gehört nicht zum Lieferumfang des Schneidenträgers R/LH100...33. Bitte separat bestellen!

Ordering note:

Wrench **P39L** ist not combined with blade R/LH100...33 - separate order required!

Das Anzugsdrehmoment der Schrauben finden Sie in den Technischen Hinweisen.

For torque specification of the screw, please see Technical Instructions.

Ersatzteile

Spare Parts

Klemmhalter Toolholder	Spannschraube Screw	TORX PLUS®-Schlüssel TORX PLUS® Wrench
R/LH100...	4.15T15P	T15PQ

Einstechen und Abstechen

Grooving and Parting Off



Klemmhalter

Toolholder

H100

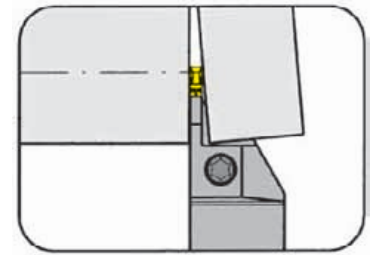

Stechtiefe bis
Stechbreite

Depth of groove up to
Width of groove

21 mm
2,5 mm

für Schneidplatte
for Insert

Typ S100
Type

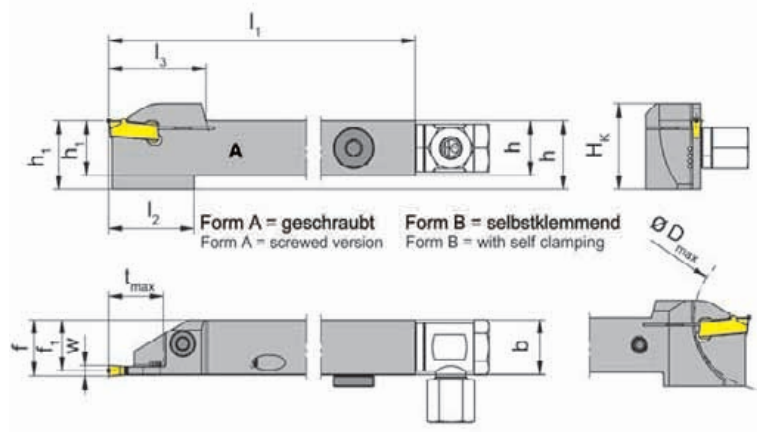

mit innerer
Kühlmittelzufuhr
with through coolant supply

R = rechts wie gezeichnet
R = right hand version shown

L = links spiegelbildlich
L = left hand version

Bestellnummer Part number	h	b	l ₁	l ₂	l ₃	h ₁	f ₁	f	t _{max}	D _{max}	H _k	Form Form	Größe Size
R/LH100.1212.02.IK	12	12	125	21	23,0	16	11,05	f ₁ +w/2	13,0	25	21	A	02
R/LH100.1616.02.IK	16	16	125	19	21,0	20	15,05	f ₁ +w/2	10,5	42	25	A	02
R/LH100.1212.12.IK	12	12	125	24	26,0	16	11,05	f ₁ +w/2	16,0	42	25	A	02
R/LH100.1616.12.IK	16	16	125	24	28,5	20	15,05	f ₁ +w/2	16,0	42	25	A	02
R/LH100.2020.12.IK	20	20	125	-	26,0	20	19,05	f ₁ +w/2	16,0	42	25	A	02
R/LH100.1616.22.IK	16	16	125	30	33,5	20	15,05	f ₁ +w/2	21,0	42	25	A	02
R/LH100.2020.22.IK	20	20	125	-	33,5	20	19,05	f ₁ +w/2	21,0	42	25	A	02
R/LH100.2525.22.IK	25	25	150	-	33,5	25	24,05	f ₁ +w/2	21,0	42	30	A	02

Ausführung R oder L angeben
State R or L version

w siehe Schneidplatten
w see inserts

Abmessungen in mm
Dimensions in mm

Weitere Abmessungen auf Anfrage
Further sizes upon request

Das Anzugsdrehmoment der Schrauben finden Sie in den Technischen Hinweisen.
For torque specification of the screw, please see Technical Instructions.

Ersatzteile

Spare Parts

Klemmhalter Toolholder	Spannschraube Screw	Kühlmittelanschluss Coolant supply	TORX PLUS®-Schlüssel TORX PLUS® Wrench	Dichtstopfen Sealing plug
R/LH100.1212...	4.15T15P	004.00.61	T15PQ	
R/LH100.1616.02.IK	4.15T15P	004.00.61	T15PQ	004.00.26
R/LH100.1616.22.IK	4.15T15P	004.00.16	T15PQ	004.00.26
R/LH100.2020.22.IK	5.17T20P	004.00.16	T20PQ	004.00.26
R/LH100.2525.22.IK	4.15T15P	004.00.16	T15PQ	004.00.26

Einstechen und Abstechen

Grooving and Parting Off



Klemmhalter

Toolholder

H100

mit Schraubklemmung
with screwed clamping

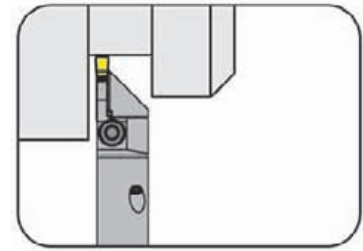

Stechtiefe bis Stechbreite	Depth of groove up to Width of groove	13,5 mm 3 mm
-------------------------------	--	-----------------

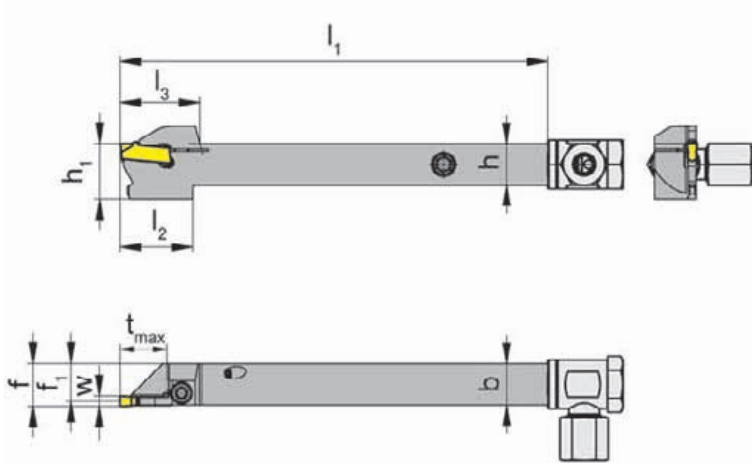

für Schneidplatte
for Insert

Typ S100
Type

mit innerer
Kühlmittelzufuhr
with through coolant supply

R = rechts wie gezeichnet
R = right hand version shown

L = links spiegelbildlich
L = left hand version

Bestellnummer Part number	h	b	l ₁	l ₂	l ₃	h ₁	f ₁	f	t _{max}	Größe Size
R/LH100.1212.5.23.IK	12	12	125	21	23	16	10,85	f ₁ +w/2	13,5	03

Ausführung R oder L angeben
State R or L version

w siehe Schneidplatten
w see inserts

Abmessungen in mm
Dimensions in mm

Weitere Abmessungen auf Anfrage
Further sizes upon request

Ersatzteile

Spare Parts

Klemmhalter Toolholder	Spannschraube Screw	Kühlmittelanschluss Coolant supply	TORX PLUS®-Schlüssel TORX PLUS® Wrench
R/LH100.1212.5.23.IK	4.15T15P	004.00.61	T15PQ



Einstechen und Abstechen

Grooving and Parting Off



Klemmhalter

Toolholder

H100

mit Schraubklemmung
with screwed clamping

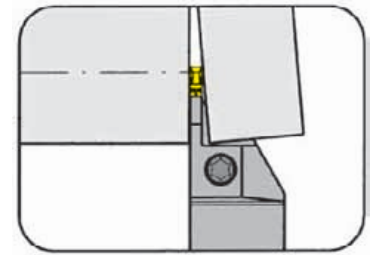

Stechtiefe bis Stechbreite	Depth of groove up to Width of groove	17 mm 2 - 3 mm
-------------------------------	--	-------------------

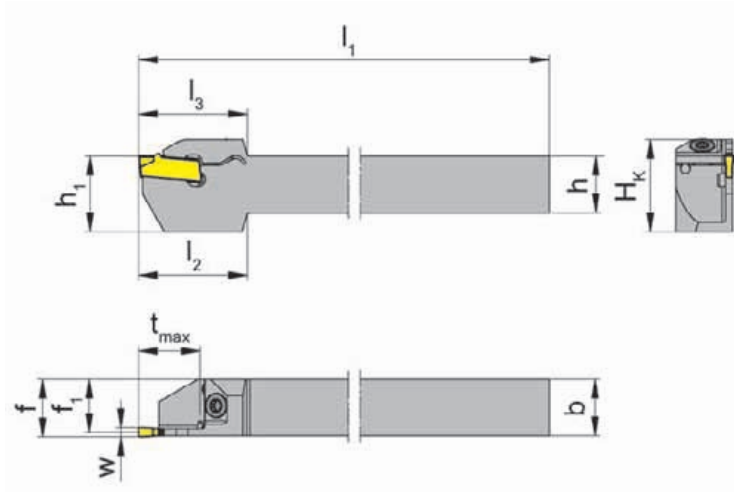

für Schneidplatte
for insert

Typ S100
Type

für Langdrehautomaten
for Swiss type machines

R = rechts wie gezeichnet
R = right hand version shown

L = links spiegelbildlich
L = left hand version

Bestellnummer Part number	h	b	l ₁	l ₂	l ₃	h ₁	f ₁	f	t _{max}	D _{max}	H _k	Größe Size
R/LH100.1212.24.61	12	12	125	23	23	12	11,25	f ₁ +w/2	13	26	19,5	02
R/LH100.1212.32.63	12	12	125	27	24	12	10,85	f ₁ +w/2	17	34	19,5	03
R/LH100.1616.24.61	16	16	125	23	-	16	15,25	f ₁ +w/2	13	26	19,5	02
R/LH100.1616.32.63	16	16	125	27	-	16	14,85	f ₁ +w/2	17	34	19,5	03

Ausführung R oder L angeben
State R or L version

w siehe Schneidplatten
w see inserts

Abmessungen in mm
Dimensions in mm

Weitere Abmessungen auf Anfrage
Further sizes upon request

Das Anzugsdrehmoment der Schrauben finden Sie in den Technischen Hinweisen.
For torque specification of the screw, please see Technical Instructions.

Ersatzteile

Spare Parts

Klemmhalter Toolholder	Spannschraube Screw	TORX PLUS®-Schlüssel TORX PLUS® Wrench
R/LH100...	3.5.12T10EP	T10PL

Einstechen und Abstechen

Grooving and Parting Off



Klemmhalter

Toolholder

H100

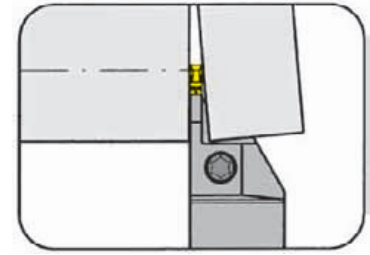

Stechtiefe bis	Depth of groove up to	32,5 mm
Stechbreite	Width of groove	3,0 mm

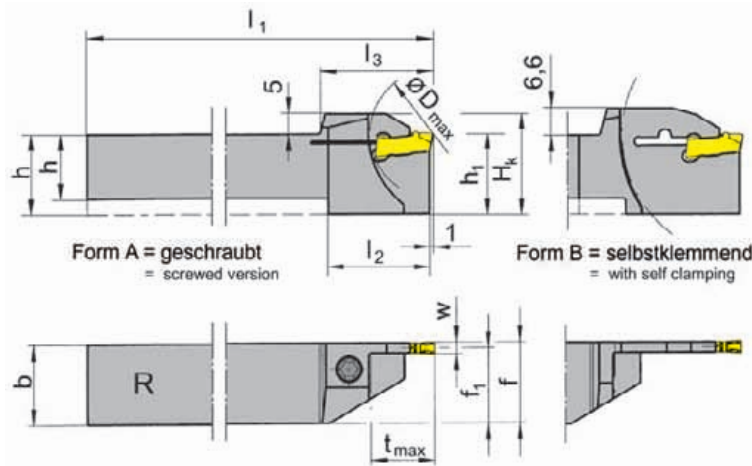

für Schneidplatte
for Insert

Typ S100
Type

R = rechts wie gezeichnet
R = right hand version shown

L = links spiegelbildlich
L = left hand version

Bestellnummer Part number	h	b	l ₁	l ₂	l ₃	h ₁	f ₁	f	t _{max}	D _{max}	H _K	Form Form	Größe Size
R/LH100.1212.03	12	12	125	21,0	23,0	16	10,85	f ₁ +w/2	13,0	26	25,0	A	03
R/LH100.1616.03	16	16	125	19,5	23,0	20	14,85	f ₁ +w/2	10,5	42	25,0	A	03
R/LH100.1616.13	16	16	125	25,0	28,5	20	14,85	f ₁ +w/2	16,0	42	25,0	A	03
R/LH100.1616.23	16	16	125	30,0	33,5	20	14,85	f ₁ +w/2	21,0	42	25,0	A	03
R/LH100.2020.13	20	20	125	-	28,5	20	18,85	f ₁ +w/2	16,0	42	25,0	A	03
R/LH100.2020.23	20	20	125	-	33,5	20	18,85	f ₁ +w/2	21,0	42	25,0	A	03
R/LH100.2020.33	20	20	125	35,0	38,5	25	18,85	f ₁ +w/2	32,5	65	31,6	B	03
R/LH100.2525.13	25	25	150	-	28,5	25	23,85	f ₁ +w/2	16,0	42	30,0	A	03
R/LH100.2525.23	25	25	150	-	33,5	25	23,85	f ₁ +w/2	21,0	42	30,0	A	03
R/LH100.2525.33	25	25	150	-	38,5	25	23,85	f ₁ +w/2	32,5	65	31,6	B	03

Ausführung R oder L angeben
State R or L version

w siehe Schneidplatten
w see inserts

Abmessungen in mm
Dimensions in mm

Weitere Abmessungen auf Anfrage
Further sizes upon request

Bestellhinweis:

Der Schlüssel **P39L** gehört nicht zum Lieferumfang des Schneidenträgers R/LH100...33. Bitte separat bestellen!

Ordering note:

Wrench **P39L** ist not combined with blade R/LH100...33 - separate order required!

Das Anzugsdrehmoment der Schrauben finden Sie in den Technischen Hinweisen.

For torque specification of the screw, please see Technical Instructions.

Ersatzteile

Spare Parts

Klemmhalter Toolholder	Spannschraube Screw	TORX PLUS®-Schlüssel TORX PLUS® Wrench	Spannschlüssel Wrench
R/LH100...	4.15T15P	T15PQ	-
R/LH100...33	-	-	P39L

Einstechen und Abstechen

Grooving and Parting Off



Klemmhalter

Toolholder

H100

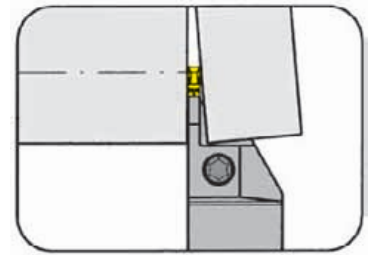

Stechtiefe bis Stechbreite	Depth of groove up to Width of groove	32,5 mm 3 mm
-------------------------------	--	-----------------

für Schneidplatte
for Insert

Typ S100
Type

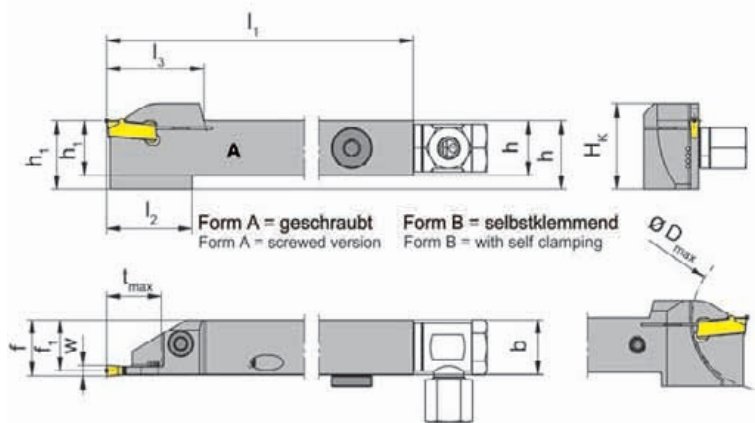

mit innerer
Kühlmittelzufuhr
with through coolant supply

R = rechts wie gezeichnet
R = right hand version shown

L = links spiegelbildlich
L = left hand version

Bestellnummer Part number	h	b	l ₁	l ₂	l ₃	h ₁	f ₁	f	t _{max}	D _{max}	H _k	Form Form	Größe Size
R/LH100.1212.03.IK	12	12	125	21,0	23,0	16	10,85	f ₁ +w/2	13,0	26	25,0	A	03
R/LH100.1616.03.IK	16	16	125	19,5	23,0	20	14,85	f ₁ +w/2	10,5	42	25,0	A	03
R/LH100.1616.13.IK	16	16	125	25,0	28,5	20	14,85	f ₁ +w/2	16,0	42	25,0	A	03
R/LH100.2020.13.IK	20	20	125	-	28,5	20	18,85	f ₁ +w/2	16,0	42	25,0	A	03
R/LH100.2525.13.IK	25	25	150	-	28,5	25	23,85	f ₁ +w/2	16,0	42	30,0	A	03
R/LH100.1616.23.IK	16	16	125	30,0	33,5	20	14,85	f ₁ +w/2	21,0	42	25,0	A	03
R/LH100.2020.23.IK	20	20	125	-	33,5	20	18,85	f ₁ +w/2	21,0	42	25,0	A	03
R/LH100.2525.23.IK	25	25	150	-	33,5	25	23,85	f ₁ +w/2	21,0	42	30,0	A	03
R/LH100.2020.33.IK	20	20	125	35,0	38,5	25	18,85	f ₁ +w/2	32,5	65	31,6	B	03
R/LH100.2525.33.IK	25	25	150	-	38,5	25	23,85	f ₁ +w/2	32,5	65	31,6	B	03

Ausführung R oder L angeben
State R or L version

w siehe Schneidplatten
w see inserts

Abmessungen in mm
Dimensions in mm

Weitere Abmessungen auf Anfrage
Further sizes upon request

Bestellhinweis:

Der Schlüssel **P39L** gehört nicht zum Lieferumfang des Schneidenträgers R/LH100...33. Bitte separat bestellen!

Ordering note:

Wrench **P39L** ist not combined with blade R/LH100...33 - separate order required!

Das Anzugsdrehmoment der Schrauben finden Sie in den Technischen Hinweisen.

For torque specification of the screw, please see Technical Instructions.

Ersatzteile

Spare Parts

Klemmhalter Toolholder	Spannschraube Screw	Kühlmittelanschluss Coolant supply	TORX PLUS®-Schlüssel TORX PLUS® Wrench	Dichtstopfen Sealing plug	Spannschlüssel Wrench
R/LH100...33IK	-	004.00.61	-	004.00.26	P39L
R/LH100...IK	5.17T20P	004.00.16	T20PQ	004.00.26	-

Einstechen und Abstechen

Grooving and Parting Off



Klemmhalter

Toolholder

H100

mit Schraubklemmung
with screwed clamping

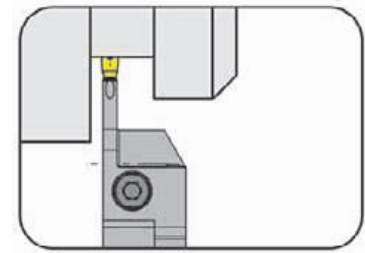

Stechtiefe bis Stechbreite	Depth of groove up to Width of groove	21,5 mm 3 - 4 mm
-------------------------------	--	---------------------

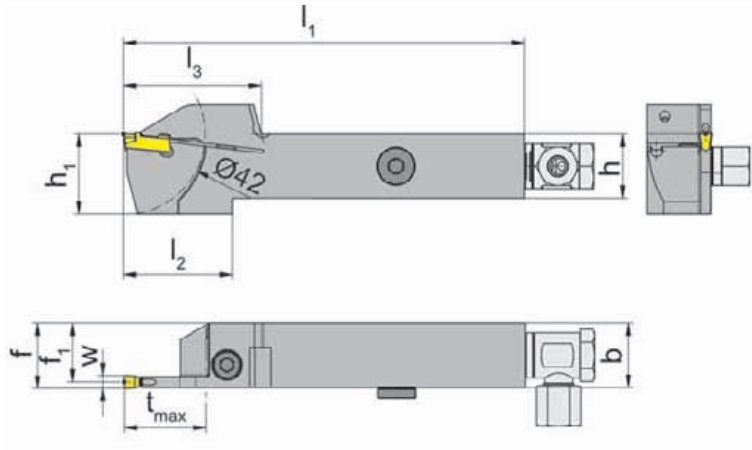

für Schneidplatte
for insert

Typ S100
Type

mit innerer
Kühlmittelzufuhr
with through coolant supply

R = rechts wie gezeichnet
R = right hand version shown

L = links spiegelbildlich
L = left hand version

Bestellnummer Part number	h	b	l ₁	l ₂	l ₃	h ₁	f ₁	f	t _{max}	Größe Size
R/LH100.1616.0.23.IK	16	16	125	35	39	25	14,65	f ₁ +w/2	21,5	03
R/LH100.2020.0.23.IK	20	20	125	33	39	25	18,65	f ₁ +w/2	21,5	03
R/LH100.2525.0.23.IK	25	25	150	33	39	30	23,65	f ₁ +w/2	21,5	03
R/LH100.1616.0.24.IK	16	16	125	35	39	25	14,30	f ₁ +w/2	21,5	04
R/LH100.2020.0.24.IK	20	20	125	33	39	25	18,30	f ₁ +w/2	21,5	04
R/LH100.2525.0.24.IK	25	25	150	33	39	30	23,30	f ₁ +w/2	21,5	04

Ausführung R oder L angeben
State R or L version

w siehe Schneidplatten
w see inserts

Abmessungen in mm
Dimensions in mm

Weitere Abmessungen auf Anfrage
Further sizes upon request

Das Anzugsdrehmoment der Schrauben finden Sie in den Technischen Hinweisen.
For torque specification of the screw, please see Technical Instructions.

Ersatzteile

Spare Parts

Klemmhalter Toolholder	Dichtstopfen Sealing plug	Kühlmittelanschluss Coolant supply	Spannschraube Screw	TORX PLUS®-Schlüssel TORX PLUS® Wrench
R/LH100...	004.00.26	004.00.16	6.23T25P	T25PQ

Einstechen und Abstechen

Grooving and Parting Off



Klemmhalter

Toolholder

H100

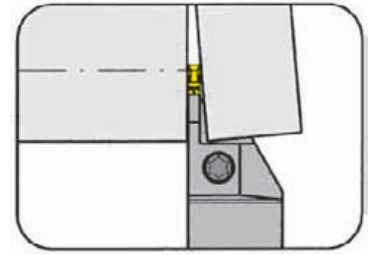

Stechtiefe bis	Depth of groove up to	40,5 mm
Stechbreite	Width of groove	4,0 mm

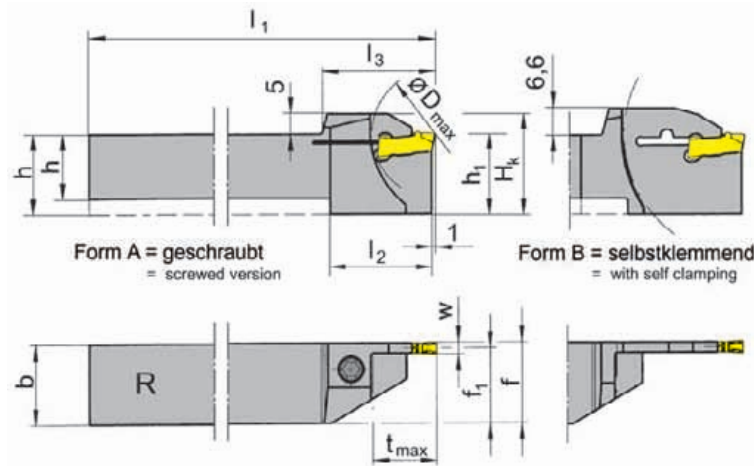

für Schneidplatte
for Insert

Typ S100
Type

R = rechts wie gezeichnet
R = right hand version shown

L = links spiegelbildlich
L = left hand version

Bestellnummer Part number	h	b	l_1	l_2	l_3	h_1	f_1	f	t_{max}	D_{max}	H_K	Form Form	Größe Size
R/LH100.1616.04	16	16	125	19,5	23,0	20	14,45	$f_1+w/2$	10,5	42	25,0	A	04
R/LH100.1616.14	16	16	125	25,0	28,5	20	14,45	$f_1+w/2$	16,0	42	25,0	A	04
R/LH100.1616.24	16	16	125	30,0	33,5	20	14,45	$f_1+w/2$	21,0	42	25,0	A	04
R/LH100.2020.14	20	20	125	-	28,5	20	18,45	$f_1+w/2$	16,0	42	25,0	A	04
R/LH100.2020.34	20	20	125	35,0	38,5	25	18,45	$f_1+w/2$	32,5	65	31,6	B	04
R/LH100.2525.14	25	25	150	-	28,5	25	23,45	$f_1+w/2$	16,0	42	30,0	A	04
R/LH100.2525.34	25	25	150	40,0	46,5	32	23,45	$f_1+w/2$	40,5	81	31,6	B	04

Ausführung R oder L angeben
State R or L version

w siehe Schneidplatten
w see inserts

Abmessungen in mm
Dimensions in mm

Weitere Abmessungen auf Anfrage
Further sizes upon request

Bestellhinweis:

Der Schlüssel **P39L** gehört nicht zum Lieferumfang des Schneidenträgers R/LH100...33. Bitte separat bestellen!

Ordering note:

Wrench **P39L** ist not combined with blade R/LH100...33 - separate order required!

Das Anzugsdrehmoment der Schrauben finden Sie in den Technischen Hinweisen.

For torque specification of the screw, please see Technical Instructions.

Ersatzteile

Spare Parts

Klemmhalter Toolholder	Spannschraube Screw	TORX PLUS®-Schlüssel TORX PLUS® Wrench
R/LH100...	5.17T20P	T20PQ

Einstechen und Abstechen

Grooving and Parting Off



Klemmhalter

Toolholder

H100

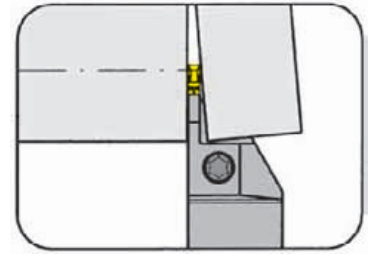

Stechtiefe bis Stechbreite	Depth of groove up to Width of groove	40,5 mm 5,0 mm
-------------------------------	--	-------------------

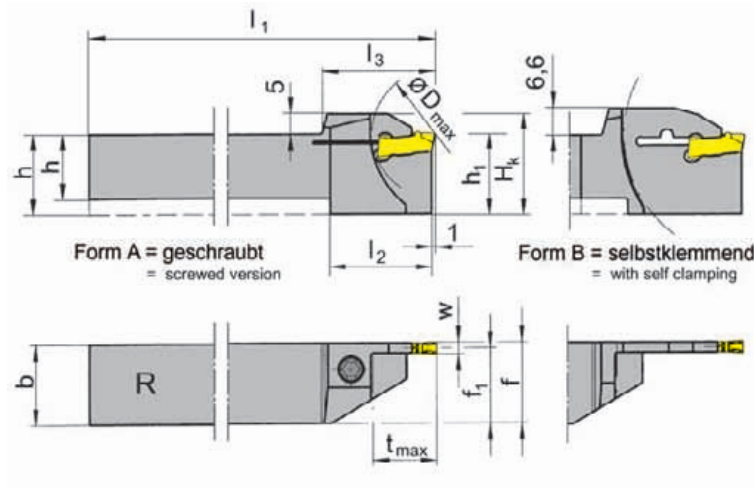

für Schneidplatte
for Insert

Typ S100
Type

R = rechts wie gezeichnet
R = right hand version shown

L = links spiegelbildlich
L = left hand version

Bestellnummer Part number	h	b	l ₁	l ₂	l ₃	h ₁	f ₁	f	t _{max}	D _{max}	H _K	Form Form	Größe Size
R/LH100.2020.15	20	20	125	-	28,5	20	18,05	f ₁ +w/2	16,0	42	25,0	A	05
R/LH100.2020.35	20	20	125	35	38,5	25	18,05	f ₁ +w/2	32,5	65	31,6	B	05
R/LH100.2525.15	25	25	150	-	28,5	25	23,05	f ₁ +w/2	16,0	42	30,0	A	05
R/LH100.2525.35	25	25	150	40	46,5	32	23,05	f ₁ +w/2	40,5	81	38,6	B	05

Ausführung R oder L angeben
State R or L version

w siehe Schneidplatten
w see inserts

Abmessungen in mm
Dimensions in mm

Weitere Abmessungen auf Anfrage
Further sizes upon request

Bestellhinweis:

Der Schlüssel **P39L** gehört nicht zum Lieferumfang des Schneidenträgers R/LH100...33. Bitte separat bestellen!

Ordering note:

Wrench **P39L** ist not combined with blade R/LH100...33 - separate order required!

Das Anzugsdrehmoment der Schrauben finden Sie in den Technischen Hinweisen.

For torque specification of the screw, please see Technical Instructions.

Ersatzteile

Spare Parts

Klemmhalter Toolholder	Spannschraube Screw	TORX PLUS®-Schlüssel TORX PLUS® Wrench
R/LH100....	5.17T20P	T20PQ

Einstechen und Abstechen

Grooving and Parting Off



Klemmhalter

Toolholder

H100

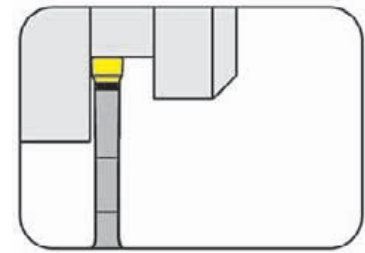

Stechtiefe bis	Depth of groove up to	41 mm
Stechbreite	Width of groove	4,0 - 12,0 mm

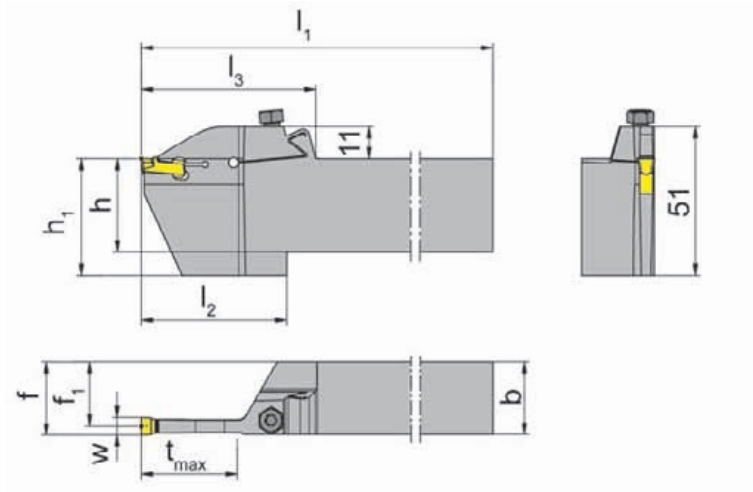

für Schneidplatte
for Insert

Typ S100
Type

R = rechts wie gezeichnet
R = right hand version shown

L = links spiegelbildlich
L = left hand version

Bestellnummer Part number	h	b	l ₁	l ₂	l ₃	h ₁	f ₁	f	t _{max}	Größe Size
R/LH100.2020.3.04	20	20	150	50	60	32	18,2	f ₁ +w/2	33	04
R/LH100.2020.3.05	20	20	150	50	60	32	17,7	f ₁ +w/2	33	05
R/LH100.2525.3.05	25	25	150	50	60	32	22,7	f ₁ +w/2	33	05
R/LH100.2525.3.06	25	25	150	50	60	40	22,2	f ₁ +w/2	33	06
R/LH100.3225.3.06	32	25	170	50	60	40	22,2	f ₁ +w/2	33	06
R/LH100.3225.3.08	32	25	170	50	60	40	21,2	f ₁ +w/2	33	08
R/LH100.3225.3.8	32	25	170	50	60	40	21,2	f ₁ +w/2	35	08
R/LH100.3225.4.08	32	25	170	55	65	40	21,2	f ₁ +w/2	41	08
R/LH100.3225.4.10	32	25	170	55	65	40	20,3	f ₁ +w/2	41	10
R/LH100.3225.4.12	32	25	170	55	65	40	19,3	f ₁ +w/2	41	12

Ausführung R oder L angeben
State R or L version

w siehe Schneidplatten
w see inserts

Abmessungen in mm
Dimensions in mm

Weitere Abmessungen auf Anfrage
Further sizes upon request

Das Anzugsdrehmoment der Schrauben finden Sie in den Technischen Hinweisen.
For torque specification of the screw, please see Technical Instructions.

Ersatzteile

Spare Parts

Klemmhalter Toolholder	Spannschraube Screw	TORX PLUS®-Schlüssel TORX PLUS® Wrench
R/LH100...	030.6075.T20P	T20PQ

Einstechen und Abstechen

Grooving and Parting Off



Klemmhalter

Toolholder

H100

mit Schraubklemmung
with screwed clamping

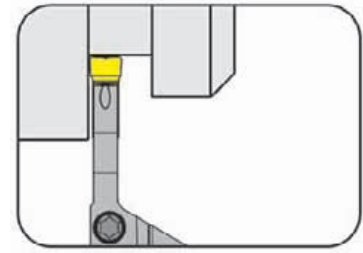

Stechtiefe bis Stechbreite	Depth of groove up to Width of groove	33 mm 4 mm
-------------------------------	--	---------------

für Schneidplatte
for Insert

Typ S100
Type

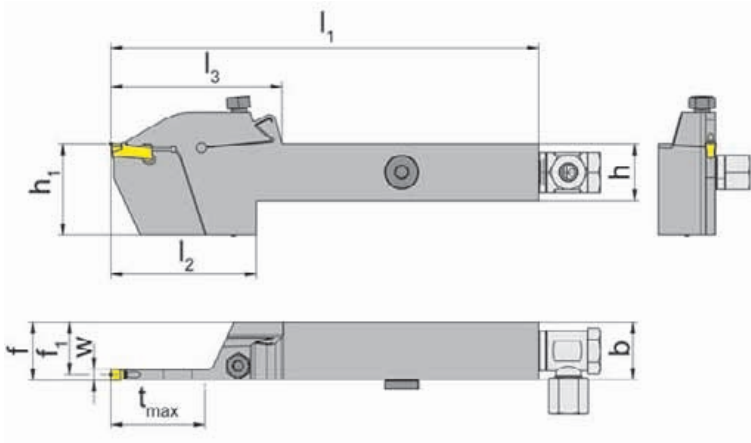

R = rechts wie gezeichnet
R = right hand version shown

L = links spiegelbildlich
L = left hand version

mit innerer
Kühlmittelzufuhr
with through coolant supply

Bestellnummer Part number	h	b	l ₁	l ₂	l ₃	h ₁	f ₁	f	t _{max}	Größe Size
R/LH100.2020.3.0.04.IK	20	20	150	51	60	32	18,3	f ₁ +w/2	33	04
R/LH100.2525.3.0.04.IK	25	25	150	50	60	32	23,3	f ₁ +w/2	33	04

Ausführung R oder L angeben
State R or L version

w siehe Schneidplatten
w see inserts

Abmessungen in mm
Dimensions in mm

Weitere Abmessungen auf Anfrage
Further sizes upon request

Ersatzteile

Spare Parts

Klemmhalter Toolholder	Dichtstopfen Sealing plug	Kühlmittelanschluss Coolant supply	Spannschraube Screw	TORX PLUS®-Schlüssel TORX PLUS® Wrench
R/LH100...	004.00.26	004.00.16	030.6075.T20P	T20PQ



Einstechen und Abstechen

Grooving and Parting Off



Klemmhalter

Toolholder

H100

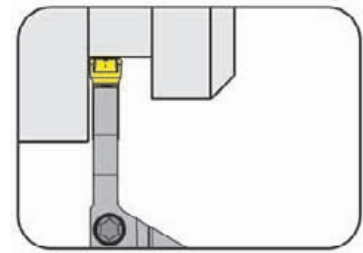

Stechtiefe bis	Depth of groove up to	45 mm
Stechbreite	Width of groove	16 mm

für Schneidplatte
for Insert

Typ S100
Type

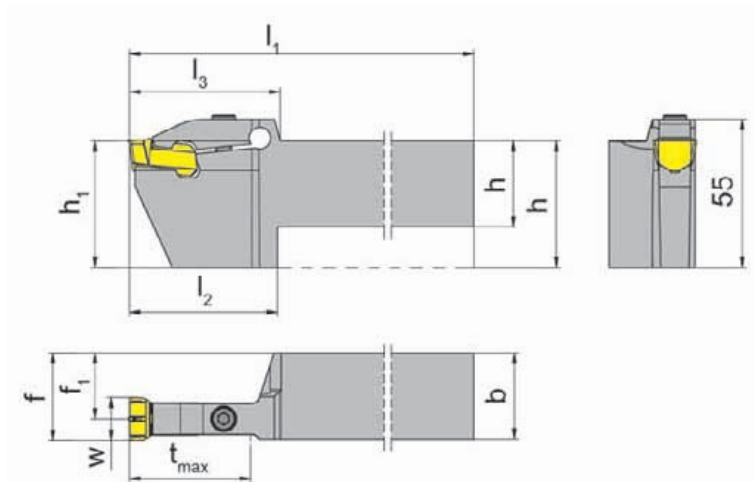

R = rechts wie gezeichnet
R = right hand version shown

L = links spiegelbildlich
L = left hand version

Bestellnummer Part number	h	b	l ₁	l ₂	h ₁	f ₁	f	t _{max}	l ₃	Größe Size
R/LH100.3232.5.16	32	32	170	55	47	24,5	f ₁ +w/2	45	56	16

Ausführung R oder L angeben
State R or L version

w siehe Schneidplatten
w see inserts

Abmessungen in mm
Dimensions in mm

Weitere Abmessungen auf Anfrage
Further sizes upon request

Das Anzugsdrehmoment der Schrauben finden Sie in den Technischen Hinweisen.
For torque specification of the screw, please see Technical Instructions.

Ersatzteile

Spare Parts

Klemmhalter Toolholder	Spannschraube Screw	TORX PLUS®-Schlüssel TORX PLUS® Wrench
R/LH100.3232.5.16	030.0625.T25P	T25PQ

Einstechen und Abstechen

Grooving and Parting Off



Klemmhalter

Toolholder

H100

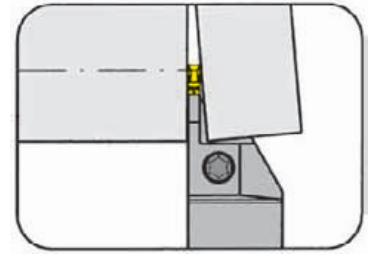

Stechtiefe bis Stechbreite	Depth of groove up to Width of groove	25 mm 3 - 4 mm
-------------------------------	--	-------------------

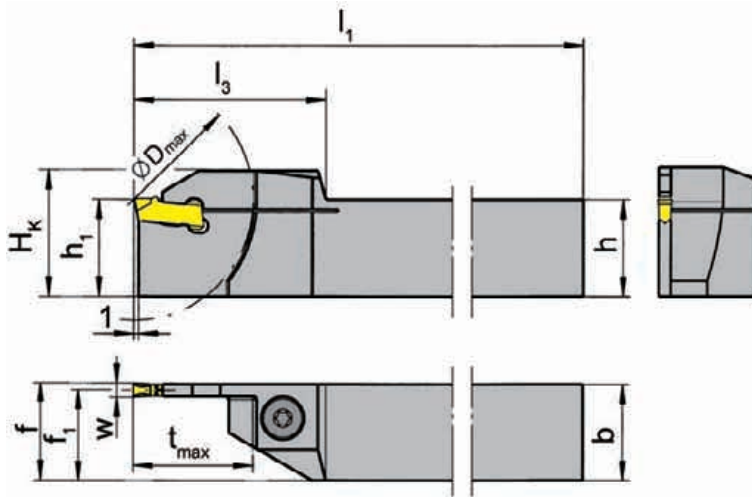

für Schneidplatte
for Insert

Typ S100
Type

L = links wie gezeichnet
L = left hand version shown

R = rechts spiegelbildlich
R = right hand version

Bestellnummer Part number	h	b	l ₁	l ₃	h ₁	f ₁	f	t _{max}	D _{max}	H _K	Größe Size
R/LH100.2020.73	20	20	125	40	20	18,85	f ₁ +w/2	25	50	26	03
R/LH100.2525.73	25	25	150	40	25	23,85	f ₁ +w/2	25	50	31	03
R/LH100.2020.74	20	20	125	40	20	18,85	f ₁ +w/2	25	50	26	04

Ausführung R oder L angeben
State R or L version

w siehe Schneidplatten
w see inserts

Abmessungen in mm
Dimensions in mm

Weitere Abmessungen auf Anfrage
Further sizes upon request

Das Anzugsdrehmoment der Schrauben finden Sie in den Technischen Hinweisen.
For torque specification of the screw, please see Technical Instructions.

Ersatzteile

Spare Parts

Klemmhalter Toolholder	Spannschraube Screw	TORX PLUS®-Schlüssel TORX PLUS® Wrench
R/LH100...	6.23T25P	T25PQ

Einstechen und Abstechen

Grooving and Parting Off



Klemmhalter

Toolholder

H100

mit Schraubklemmung
with screwed clamping

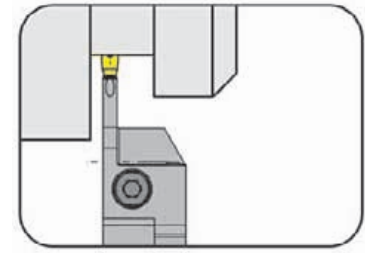

Stechtiefe bis Stechbreite	Depth of groove up to Width of groove	25.5 3 - 4 mm
-------------------------------	--	------------------

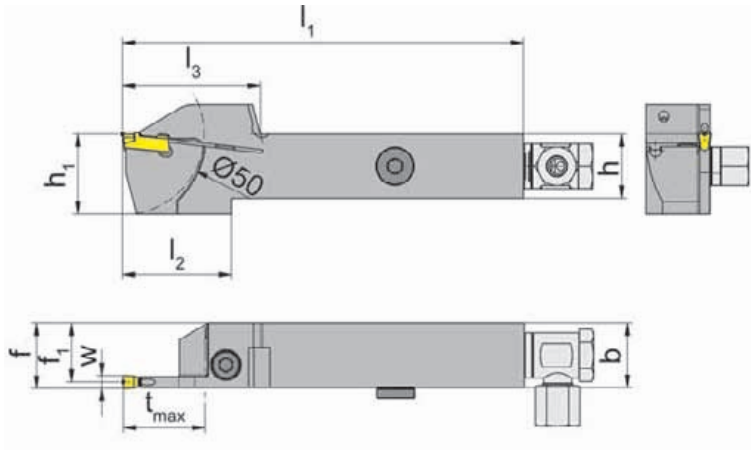

für Schneidplatte
for Insert

Typ S100
Type

mit innerer
Kühlmittelzufuhr
with through coolant supply

R = rechts wie gezeichnet
R = right hand version shown

L = links spiegelbildlich
L = left hand version

Bestellnummer Part number	h	b	l ₁	l ₂	l ₃	h ₁	f ₁	f	t _{max}	Größe Size
R/LH100.2020.0.73.IK	20	20	125	37	43	25	18,65	f ₁ +w/2	25,5	03
R/LH100.2525.0.73.IK	25	25	150	37	43	30	23,65	f ₁ +w/2	25,5	03
R/LH100.2525.0.74.IK	25	25	150	37	43	30	23,30	f ₁ +w/2	25,5	04
R/LH100.2020.0.74.IK	20	20	125	37	43	25	18,30	f ₁ +w/2	25,5	04

Ausführung R oder L angeben
State R or L version

w siehe Schneidplatten
w see inserts

Abmessungen in mm
Dimensions in mm

Weitere Abmessungen auf Anfrage
Further sizes upon request

Das Anzugsdrehmoment der Schrauben finden Sie in den Technischen Hinweisen.
For torque specification of the screw, please see Technical Instructions.

Ersatzteile

Spare Parts

Klemmhalter Toolholder	Dichtstopfen Sealing plug	Kühlmittelanschluss Coolant supply	Spannschraube Screw	TORX PLUS®-Schlüssel TORX PLUS® Wrench
R/LH100...IK	004.00.26	004.00.16	6.23T25P	T25PQ

Einstechen und Abstechen

Grooving and Parting Off



Klemmhalter

Toolholder

H100

mit Schraubklemmung
with screwed clamping

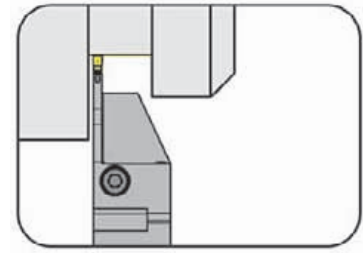

Stechtiefe bis Stechbreite	Depth of groove up to Width of groove	34 mm 3 - 4 mm
-------------------------------	--	-------------------

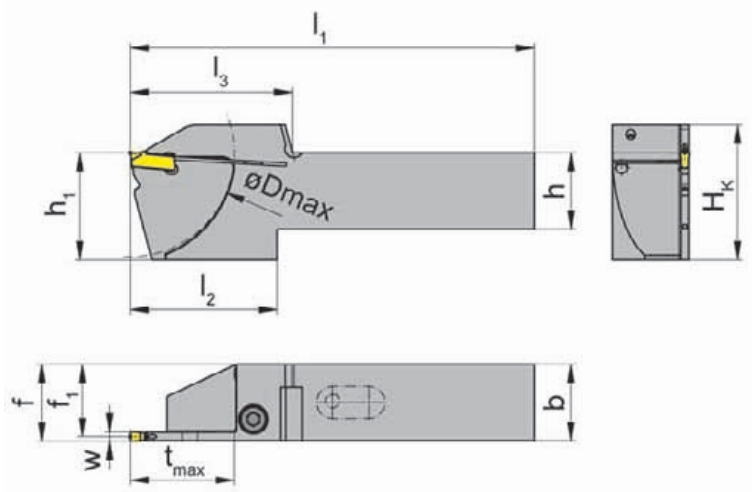

R = rechts wie gezeichnet
R = right hand version shown

L = links spiegelbildlich
L = left hand version

für Schneidplatte
for Insert

Typ S100
Type

mit integrierter innerer
Kühlmittelzufuhr
with integrated through
coolant supply

Bestellnummer Part number	h	b	l ₁	l ₂	l ₃	h ₁	f ₁	f	t _{max}	D _{max}	H _k	Größe Size
R/LH100.2525.34.4.73.IK	25	25	132	48	53	35	23,65	f ₁ +w/2	34	68	44	03
R/LH100.2020.34.4.73.IK	20	20	115	48	53	30	18,65	f ₁ +w/2	34	68	39	03

Ausführung R oder L angeben
State R or L version

w siehe Schneidplatten
w see inserts

Abmessungen in mm
Dimensions in mm

Weitere Abmessungen auf Anfrage
Further sizes upon request

Das Anzugsdrehmoment der Schrauben finden Sie in den Technischen Hinweisen.
For torque specification of the screw, please see Technical Instructions.

Ersatzteile

Spare Parts

Klemmhalter Toolholder	Spannschraube Screw	TORX PLUS®-Schlüssel TORX PLUS® Wrench
R/LH100...	6.23T25P	T25PQ

Einstechen und Abstechen (außen)

Grooving and Parting off (external)



Kassette

Cassette

NK100

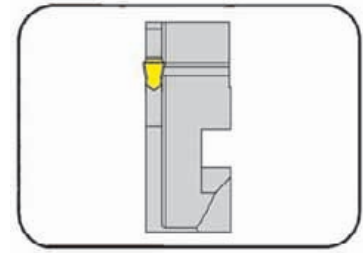

Stechtiefe bis
Stechbreite

Depth of groove up to
Width of groove

25 mm
2 - 4 mm

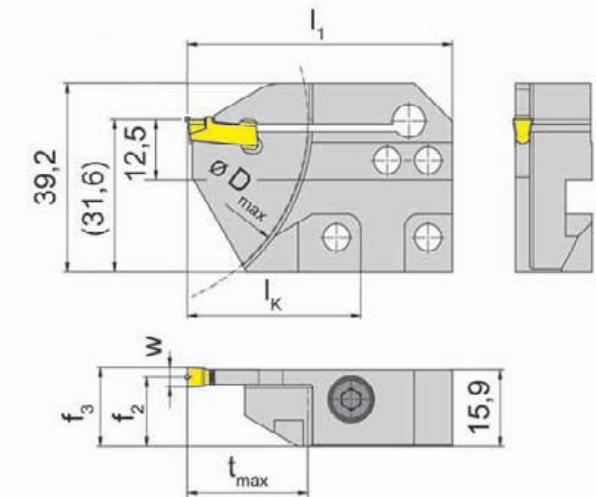

für Schneidplatte
for Insert

Typ S100
Type

L = links wie gezeichnet
L = left hand version shown

R = rechts spiegelbildlich
RL = right hand version

Bestellnummer Part number	l_1	t_{max}	w	f_3	f_2	D_{max}	l_k
R/LNK100.3215.21	55	25	2	$f_2+w/2$	15,4	80	36
R/LNK100.3215.23	55	25	3	$f_2+w/2$	14,9	80	36
R/LNK100.3215.24	55	25	4	$f_2+w/2$	14,4	80	36

Für Grundhalter R...K1 und L...K2
For basic toolholder R...K1 and L...K2

Abmessungen in mm
Dimensions in mm

Bestellhinweis:

Befestigungsschrauben der Kassetten gehören zum Lieferumfang des Grundhalters.

Ordering note:

The fastening screw is combined with the basic toolholder - no separate order required.

Das Anzugsdrehmoment der Schrauben finden Sie in den Technischen Hinweisen.

For torque specification of the screw, please see Technical Instructions.

Ausführung R oder L angeben

State R or L version

Ersatzteile

Spare Parts

Kassette Cassette	Spannschraube Screw	TORX PLUS®-Schlüssel TORX PLUS® Wrench
R/LNK100...	6.23T25P	T25PQ

Abstechen

Parting Off



Grundhalter

Basic toolholder

220

ohne Kasette
without cassette

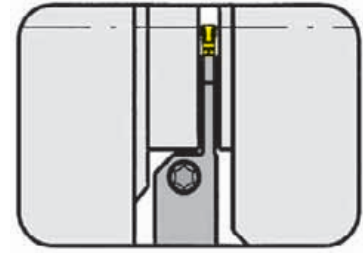

Grundhalter für Kassetten Typ RNK100
Basic adapter for cassettes type RNK100

Schaft parallel zur Drehachse
Shank parallel to the axis of workpiece

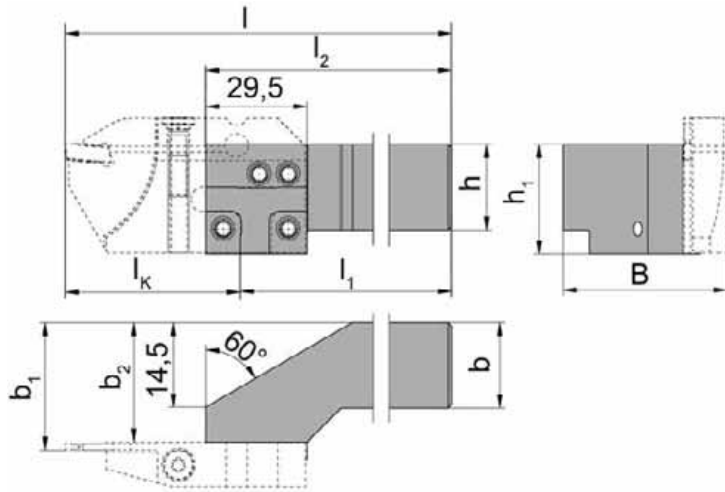

für Kasette
for Cassette

Typ RNK100...L
Type

INDEX Mehrspindler
MS52
Multi spindle system MS52

R = Rechtsausführung
R = right hand version

Bestellnummer Part number	l	b1	b ₂	B	h	l ₂	h ₁	b	l ₁
R220.2529.60.K1	l ₁ +l _K	b ₂ +f ₃	29,5	b ₂ +b ₃	25	160	32	25	l ₂ -10
R220.2535.60.K1	l ₁ +l _K	b ₂ +f ₃	34,9	b ₂ +b ₃	25	160	32	25	l ₂ -10

Weitere Abmessungen auf Anfrage
Further sizes upon request

l_K, b₃ und f₃ siehe Kassetten
l_K, b₃ and f₃ see cassettes

Abmessungen in mm
Dimensions in mm

Ersatzteile

Spare Parts

Grundhalter Basic toolholder	Spannschraube Screw	TORX PLUS®-Schlüssel TORX PLUS® Wrench
R220...	5.12T20P	T20PQ

Einstecken und Abstecken (außen)

Grooving and Parting off (external)



Kassette

Cassette

NK100

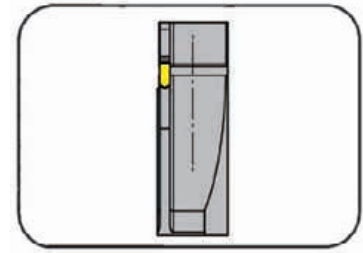

Stechtiefe bis Stechbreite	Depth of groove up to Width of groove	26 mm 2,5 - 3,0 mm
-------------------------------	--	-----------------------

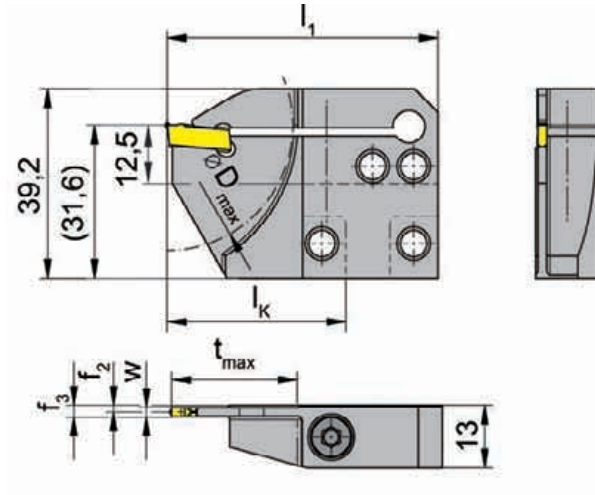

für Schneidplatte
for Insert

Typ S100
Type

R = rechts wie gezeichnet
R = right hand version shown

Bestellnummer Part number	l_1	t_{max}	w	f_3	f_2	D_{max}	l_k
RNK100.5625.02L	56	26	2,5	$f_2+w/2$	1,40	52	37
RNK100.7025.02L	70	26	2,5	$f_2+w/2$	1,40	52	51
RNK100.5625.03L	56	26	3,0	$f_2+w/2$	1,65	52	37
RNK100.7025.03L	70	26	3,0	$f_2+w/2$	1,65	52	51

Für Grundhalter R...K1 und L...K2
For basic toolholder R...K1 and L...K2

Abmessungen in mm
Dimensions in mm

Bestellhinweis:

Befestigungsschrauben der Kassetten gehören zum Lieferumfang des Grundhalters.

Ordering note:

The fastening screw is combined with the basic toolholder - no separate order required.

Das Anzugsdrehmoment der Schrauben finden Sie in den Technischen Hinweisen.

For torque specification of the screw, please see Technical Instructions.

Ersatzteile

Spare Parts

Kassette Cassette	Spannschraube Screw	TORX PLUS®-Schlüssel TORX PLUS® Wrench
RNK100.5625....	6.17T25P	T25PQ
RNK100.7025....	6.23T25P	T25PQ

Einstechen und Abstechen

Grooving and Parting Off



Schneidplatte

Insert

S100

mit Spanformrille
with chip former

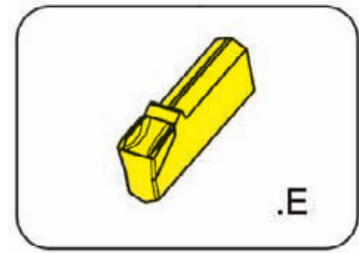

Stechbreite	Width of groove	2-5 mm
-------------	-----------------	--------

für Klemmhalter
for Toolholder

Typ H100
Type NK100

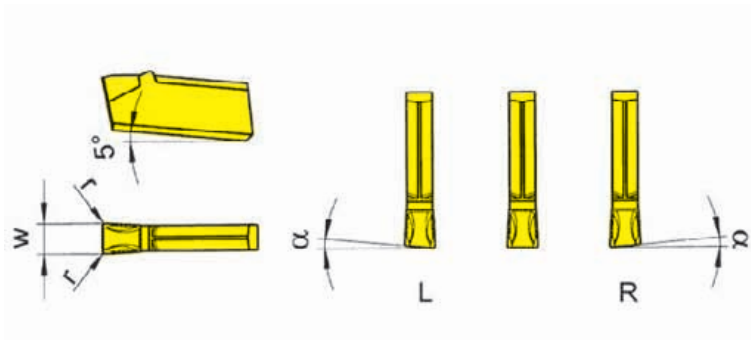

R = Rechtsausführung
R = right hand version

L = Linksausführung
L = left hand version

Bestellnummer Part number	w	r	α	Größe Size	ALX2	ALX3	AS63	AS66	TC92	TC93	TF42	TF43	TF45	TF46	Ti22
S100.0200.E2	2,0	0,2	0°	01		▲			▲	Δ		▲	▲	▲	Δ
R/L/S100.0520.E2	2,0	0,2	5°	01					Δ/Δ	Δ/Δ		▲/Δ	▲/▲	Δ/Δ	Δ/Δ
S100.0250.E2	2,5	0,2	0°	02					Δ	Δ		▲	▲	▲	▲
R/L/S100.0525.E2	2,5	0,2	5°	02					Δ/Δ	▲/Δ		▲/Δ	▲/▲	Δ/▲	Δ/Δ
S100.0300.E2	3,0	0,2	0°	03	▲	▲	▲	▲	▲	▲	▲	▲	▲	▲	▲
R/L/S100.0530.E2	3,0	0,2	5°	03		▲/Δ			Δ/▲	▲/Δ	▲/Δ	▲/▲	▲/▲	▲/▲	▲/Δ
S100.0400.E3	4,0	0,3	0°	04		▲			Δ	▲		▲	▲	▲	▲
R/L/S100.0540.E2	4,0	0,2	5°	04		Δ/Δ			Δ/Δ	Δ/Δ		▲/▲	▲/▲	Δ/Δ	Δ/Δ
S100.0500.E3	5,0	0,3	0°	05				Δ	Δ	▲		▲	▲	Δ	Δ
▲ ab Lager / on stock Δ 4 Wochen / 4 weeks x auf Anfrage / upon request					P	•	•	•	•	•	•	•	•	•	•
• empfohlen / recommended					M	-	-	o	-	-	-	-	•	o	-
o bedingt einsetzbar / alternative recommendation					K	-	-	•	-	-	-	-	•	•	-
- nicht geeignet / not suitable					N	-	-	•	-	-	-	-	•	•	-
unbeschichtete HM-Sorten / uncoated grades					S	-	-	o	-	-	-	-	•	o	-
beschichtete HM-Sorten / coated grades					H	-	-	-	-	-	-	-	-	-	-
bestückt/Cermet / brazed/Cermet															

Abmessungen in mm
Dimensions in mm
Ausführung R oder L angeben
State R or L version

HM-Sorten
Carbide grades



Einstechen und Abstechen

Grooving and Parting Off



Schneidplatte

Insert

S100

mit Spanformrinne
with chip former

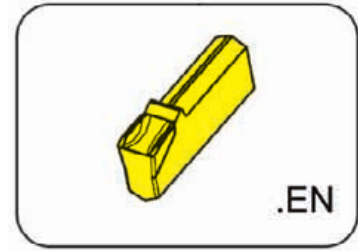

Stechbreite	Width of groove	2-16 mm
-------------	-----------------	---------

für Klemhalter
for Toolholder

Typ H100
Type NK100

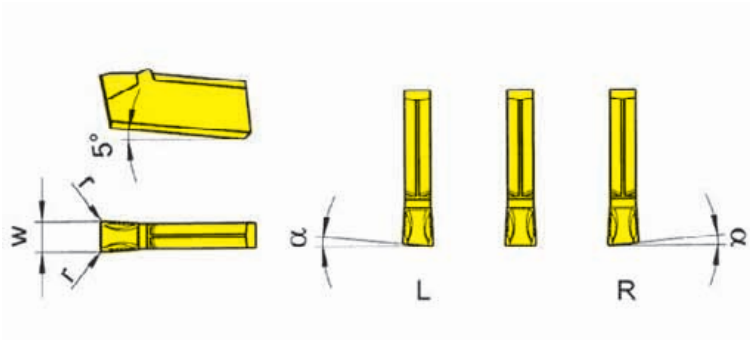

R = Rechtsausführung
R = right hand version

L = Linksausführung
L = left hand version

Bestellnummer Part number	w	r	α	Größe Size	ALX3	ALX5	AS62	AS63	AS66	AS6G	TF45	TH35
S100.0200.EN2	2,0	0,2	0°	01	▲	Δ				▲		Δ
S100.0220.EN2	2,2	0,2	0°	01	▲					▲		
S100.0250.EN2	2,5	0,2	0°	02	▲					▲		
S100.0300.EN2	3,0	0,2	0°	03	▲	Δ		▲	▲	▲	Δ	
RS100.0530.EN2	3,0	0,2	5°	03			▲		▲			
S100.0400.EN3	4,0	0,3	0°	04	▲			▲		▲		
R/LS100.0540.EN2	4,0	0,2	5°	04	▲/▲							
S100.0500.EN3	5,0	0,3	0°	05	▲							
S100.0600.EN6	6,0	0,8	0°	06						▲		
S100.0800.EN8	8,0	0,8	0°	08					▲	▲		
LS100.0480.EN8	8,0	0,8	4°	08					▲			
S100.1000.EN8	10,0	0,8	0°	10						▲		
S100.1200.EN8	12,0	0,8	0°	12						▲		
S100.1600.EN8	16,0	0,8	0°	16						▲		
P	•	•	•	•	•	•	•	•	•	•	•	•
M	-	•	-	-	o	•	•	•	•	•	•	•
K	-	•	-	-	•	•	•	•	•	•	•	•
N	-	•	-	-	•	•	•	•	•	•	•	•
S	-	•	-	-	o	•	•	•	•	•	•	•
H	-	-	-	-	-	-	-	-	-	-	-	-

- ▲ ab Lager / on stock Δ 4 Wochen / 4 weeks x auf Anfrage / upon request
- empfohlen / recommended
- o bedingt einsetzbar / alternative recommendation
- nicht geeignet / not suitable
- unbeschichtete HM-Sorten / uncoated grades
- beschichtete HM-Sorten / coated grades
- bestückt/Cermet / brazed/Cermet

Abmessungen in mm
Dimensions in mm
Ausführung R oder L angeben
State R or L version

HM-Sorten
Carbide grades

Einstechen und Abstechen

Grooving and Parting Off



Schneidplatte

Insert

S100

mit Spanformung
with chip forming

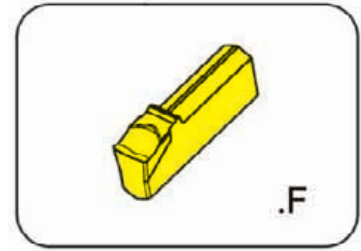

Stechbreite	Width of groove	2-5 mm
-------------	-----------------	--------

für Klemhalter
for Toolholder

Typ H100
Type NK100

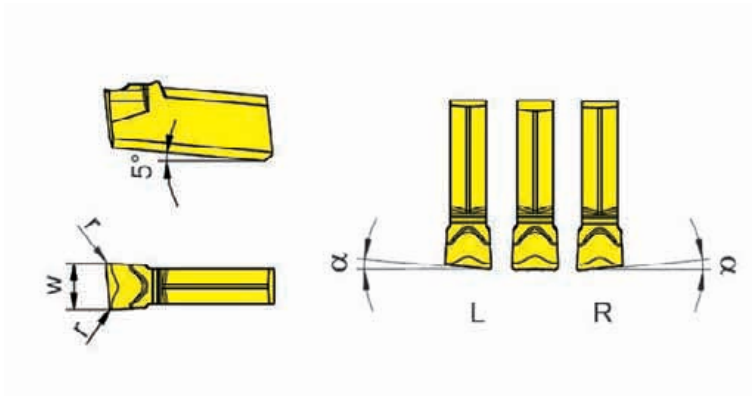

R = rechts wie gezeichnet
R = right hand version shown

L = links spiegelbildlich
L = left hand version

Bestellnummer Part number	w	r	α	Größe Size	ALX3	TC92	TC93	TF42	TF43	TF45	TF46	Ti22
S100.0200.F2	2,0	0,2	0°	01		▲	Δ		▲	▲	▲	▲
R/LS100.0520.F2	2,0	0,2	5°	01		Δ/Δ	Δ/Δ		Δ/Δ	▲/▲	▲/Δ	Δ/Δ
S100.0250.F2	2,5	0,2	0°	02		Δ	Δ		Δ	▲	Δ	▲
R/LS100.0525.F2	2,5	0,2	5°	02		Δ/Δ	Δ/Δ		Δ/Δ	▲/Δ	Δ/Δ	Δ/Δ
S100.0300.F2	3,0	0,2	0°	03		▲	▲	Δ	▲	▲	▲	▲
R/LS100.0530.F2	3,0	0,2	5°	03		Δ/Δ	Δ/▲		▲/▲	▲/▲	Δ/▲	Δ/Δ
S100.0400.F3	4,0	0,3	0°	04		Δ	Δ		▲	▲	▲	▲
R/LS100.0540.F2	4,0	0,2	5°	04		Δ/Δ	Δ/Δ		Δ/Δ	▲/▲	Δ/Δ	Δ/Δ
S100.0500.F3	5,0	0,3	0°	05	x	Δ	Δ		Δ	▲	Δ	▲
▲ ab Lager / on stock Δ 4 Wochen / 4 weeks x auf Anfrage / upon request					P	•	•	•	•	•	•	•
● empfohlen / recommended					M	-	-	-	-	•	o	-
o bedingt einsetzbar / alternative recommendation					K	-	-	-	-	•	•	-
- nicht geeignet / not suitable					N	-	-	-	-	•	•	-
■ unbeschichtete HM-Sorten / uncoated grades					S	-	-	-	-	•	o	-
■ beschichtete HM-Sorten / coated grades					H	-	-	-	-	-	-	-
■ bestückt/Cermet / brazed/Cermet												

Abmessungen in mm
Dimensions in mm
Ausführung R oder L angeben
State R or L version

HM-Sorten
Carbide grades



Einstechen und Abstechen

Grooving and Parting Off



Schneidplatte

Insert

S100

mit Spanformung
with chip forming

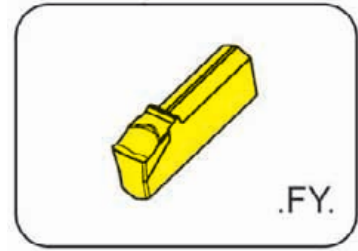

Stechbreite	Width of groove	2-4 mm
-------------	-----------------	--------

präzisionsgesintert
precision sintered

für Klemhalter
for Toolholder

Typ H100
Type NK100

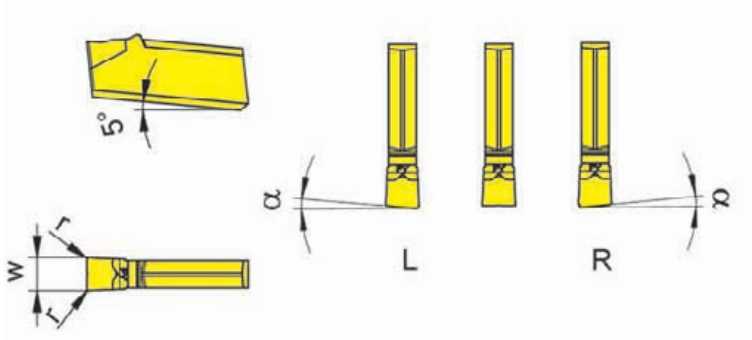

R = Rechtsausführung
R = right hand version

L = Linksausführung
L = left hand version

Bestellnummer Part number	w	r	α	Größe Size	AS45	HP65	PH35	TI25
S100.0200.FY2	2,0	0,2	0°	01	Δ	▲	▲	▲
R/LS100.1520.FY0	2,0	-	15°	01	▲/▲			
S100.0220.FY2	2,2	0,2	0°	01				▲
S100.0250.FY2	2,5	0,2	0°	02	Δ	▲		▲
S100.0300.FY2	3,0	0,2	0°	03	Δ	▲	▲	▲
R/LS100.1530.FY0	3,0	-	15°	03	▲/▲			
S100.0400.FY3	4,0	0,3	0°	04		▲		▲

▲ ab Lager / on stock Δ 4 Wochen / 4 weeks x auf Anfrage / upon request

● empfohlen / recommended

o bedingt einsetzbar / alternative recommendation

- nicht geeignet / not suitable

□ unbeschichtete HM-Sorten / uncoated grades

■ beschichtete HM-Sorten / coated grades

■ bestückt/Cermet / brazed/Cermet

Abmessungen in mm

Dimensions in mm

Schneidplatten sind in **rechten und linken** Klemmhaltern verwendbar.

Indexable inserts can be used in **right and left** hand toolholders.

Ausführung R oder L angeben

State R or L version

P	●	●	○	●
M	●	●	○	●
K	●	●	●	●
N	○	○	-	●
S	●	●	-	●
H	-	-	-	-

HM-Sorten
Carbide grades

Einstechen und Abstechen

Grooving and Parting Off



Schneidplatte

Insert

S100

mit Spanformung
with chip forming

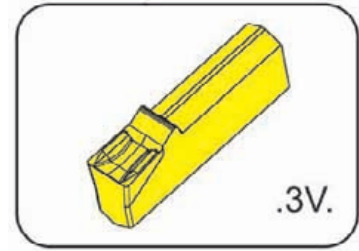

Stechbreite	Width of groove	2-4 mm
-------------	-----------------	--------

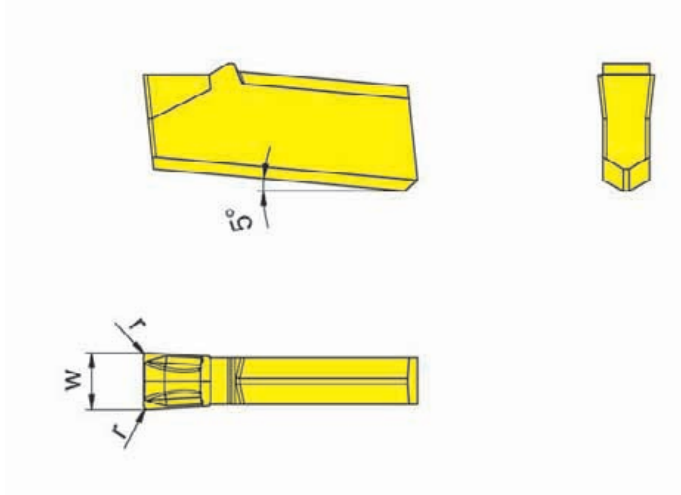

für Klemmhalter
for Toolholder

Typ H100
Type NK100

Bestellnummer Part number	w	r	Größe Size	AS45	HP35	HP65	PH35	
S100.0200.3V2	2,0	0,2	01	▲	△	▲	▲	
S100.0250.3V2	2,5	0,2	02	▲		▲		
S100.0300.3V2	3,0	0,2	03	▲		▲	▲	
S100.0400.3V3	4,0	0,3	04	▲		▲		
▲ ab Lager / on stock △ 4 Wochen / 4 weeks x auf Anfrage / upon request ● empfohlen / recommended o bedingt einsetzbar / alternative recommendation - nicht geeignet / not suitable □ unbeschichtete HM-Sorten / uncoated grades ■ beschichtete HM-Sorten / coated grades ■ bestückt/Cermet / brazed/Cermet				P	●	○	●	○
				M	●	●	●	○
				K	●	○	●	●
				N	○	-	○	-
				S	●	○	●	-
				H	-	-	-	-
Abmessungen in mm Dimensions in mm				HM-Sorten Carbide grades				



Einstechen und Abstechen

Grooving and Parting Off



Schneidplatte

Insert

S100

mit Spanformung
with chip forming

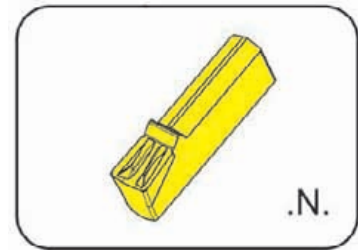

Stechbreite	Width of groove	3-4 mm
-------------	-----------------	--------

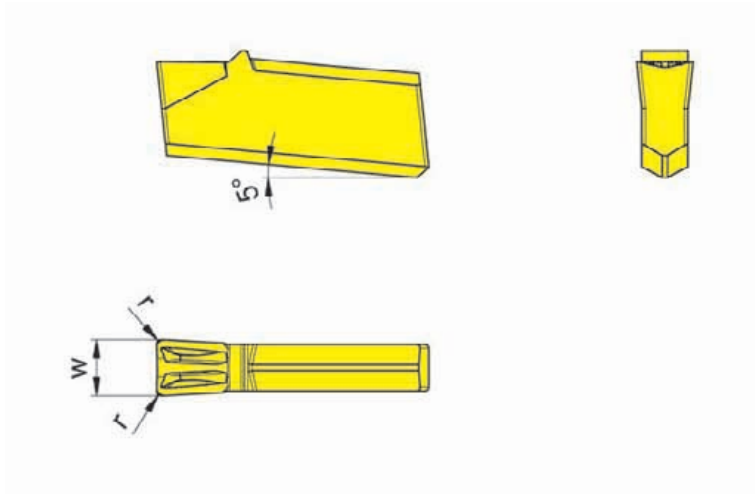

für Klemmhalter
for Toolholder

Typ H100
Type NK100

T

Bestellnummer Part number	w	r	Größe Size	AS45	HP65
S100.0300.N2	3	0,2	03	▲	▲
S100.0400.N3	4	0,3	04	▲	▲

▲ ab Lager / on stock Δ 4 Wochen / 4 weeks x auf Anfrage / upon request

● empfohlen / recommended

o bedingt einsetzbar / alternative recommendation

- nicht geeignet / not suitable

■ unbeschichtete HM-Sorten / uncoated grades

■ beschichtete HM-Sorten / coated grades

■ bestückt/Cermet / brazed/Cermet

Abmessungen in mm

Dimensions in mm

P	●	●
M	●	●
K	●	●
N	o	o
S	●	●
H	-	-

HM-Sorten
Carbide grades

Einstechen und Abstechen

Grooving and Parting Off



Schneidplatte

Insert

S100

mit Spanformung
with chip forming

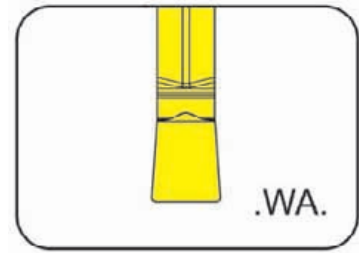

Stechbreite	Width of groove	2-3 mm
-------------	-----------------	--------

präzisionsgeschliffen und poliert
precision ground and polished

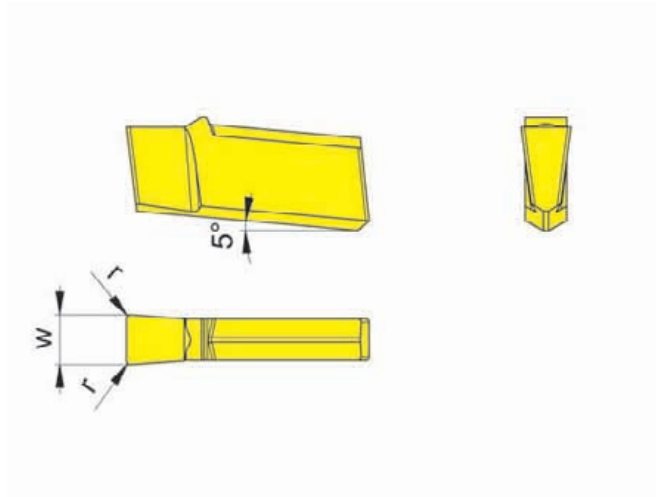

für Klemmhalter
for Toolholder

Typ H100
Type NK100

für Aluminium
for Aluminium



Bestellnummer Part number	w	r	Größe Size		K10	DD26
S100.0200.WA2	2	0,2	01		▲	▲
S100.0300.WA2	3	0,2	03		▲	▲
				P	●	-
				M	○	-
				K	●	-
				N	●	●
				S	○	○
				H	-	-

- ▲ ab Lager / on stock Δ 4 Wochen / 4 weeks x auf Anfrage / upon request
- empfohlen / recommended
- bedingt einsetzbar / alternative recommendation
- nicht geeignet / not suitable
- unbeschichtete HM-Sorten / uncoated grades
- beschichtete HM-Sorten / coated grades
- bestückt/Cermet / brazed/Cermet

Abmessungen in mm
Dimensions in mm

Schneidplatten sind in **rechten und linken** Klemmhaltern verwendbar.
Indexable inserts can be used in **right and left** hand toolholders.

HM-Sorten
Carbide grades

Einstechen und Abstechen

Grooving and Parting Off



Klemmhalter

Toolholder

H100

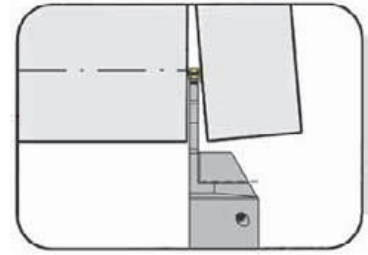

Stechtiefe bis Stechbreite	Depth of groove up to Width of groove	41 mm 3 - 4 mm
-------------------------------	--	-------------------

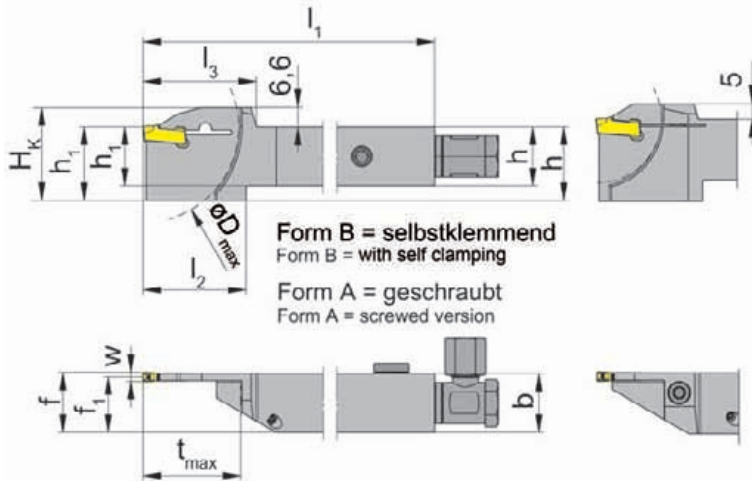

für Schneidplatte
for Insert

Typ S100...IK
Type

Kühlmittelzufuhr durch die
Schneidplatte
Coolant supply through insert

L = links wie gezeichnet
L = left hand version shown

R = rechts spiegelbildlich
R = right hand version

Bestellnummer Part number	h	b	l ₁	l ₂	l ₃	h ₁	f ₁	f	t _{max}	D _{max}	H _K	Form Form	Größe Size
R/LH100.1616.1.23.IK	16	16	125	35	33,5	27	14,85	f ₁ +w/2	21,5	42	32,0	A	03
R/LH100.2020.1.13.IK	20	20	125	30	28,5	27	18,85	f ₁ +w/2	16,0	42	32,0	A	03
R/LH100.2020.1.23.IK	20	20	125	35	33,5	27	18,85	f ₁ +w/2	21,5	42	32,0	A	03
R/LH100.2020.1.33.IK	20	20	125	35	38,5	27	18,85	f ₁ +w/2	33,0	65	33,6	B	03
R/LH100.2525.1.33.IK	25	25	150	35	38,5	32	23,85	f ₁ +w/2	33,0	65	38,6	B	03
R/LH100.2020.1.34.IK	20	20	125	35	38,5	27	18,45	f ₁ +w/2	33,0	65	33,6	B	04
R/LH100.2525.1.34.IK	25	25	150	40	46,5	32	23,45	f ₁ +w/2	41,0	81	38,6	B	04

Ausführung R oder L angeben
State R or L version

w siehe Schneidplatten
w see inserts

Abmessungen in mm
Dimensions in mm

Weitere Abmessungen auf Anfrage
Further sizes upon request

Bestellhinweis:

Der Schlüssel **P39L** gehört nicht zum Lieferumfang des Schneidenträgers R/LH100...33. Bitte separat bestellen!

Ordering note:

Wrench **P39L** ist not combined with blade R/LH100...33 - separate order required!

Das Anzugsdrehmoment der Schrauben finden Sie in den Technischen Hinweisen.

For torque specification of the screw, please see Technical Instructions.

Ersatzteile

Spare Parts

Klemmhalter Toolholder	Spannschraube Screw	Dichtstopfen Sealing plug	Kühlmittelanschluss Coolant supply	TORX PLUS®-Schlüssel TORX PLUS® Wrench	Spannschlüssel Wrench
R/LH100...13/23.IK	5.17T20P	004.00.26	004.00.16	T20PQ	-
R/LH100....	-	004.00.26	004.00.16	-	P39L

Einstechen und Abstechen

Grooving and Parting Off



Klemmhalter

Toolholder

H100

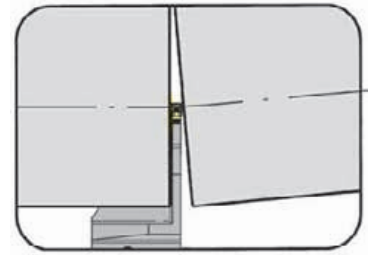

Stechtiefe bis Stechbreite	Depth of groove up to Width of groove	33 mm 3 mm
-------------------------------	--	---------------

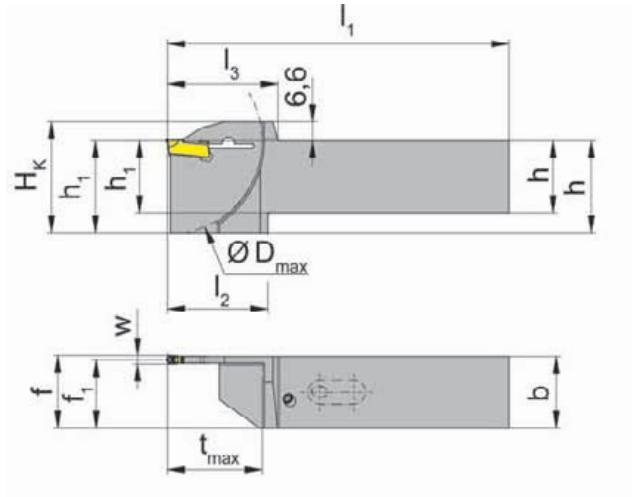

für Schneidplatte
for insert

Typ S100...IK
Type

Kühlmittelzufuhr durch die
Schneidplatte
Coolant supply through insert

L = links wie gezeichnet
L = left hand version shown

R = rechts spiegelbildlich
R = right hand version

Bestellnummer Part number	h	b	l ₁	l ₂	l ₃	h ₁	f ₁	f	t _{max}	D _{max}	H _k	Größe Size
R/LH100.2020.3.33.IK	20	20	104	35	38,5	27	18,85	f ₁ +w/2	33	65	33,6	03
R/LH100.2525.3.33.IK	25	25	119	35	38,5	32	23,85	f ₁ +w/2	33	65	38,6	03

Ausführung R oder L angeben
State R or L version

w siehe Schneidplatten
w see inserts

Abmessungen in mm
Dimensions in mm

Weitere Abmessungen auf Anfrage
Further sizes upon request

Bestellhinweis:

Der Schlüssel **P39L** gehört nicht zum Lieferumfang des Schneidenträgers R/LH100...33. Bitte separat bestellen!

Ordering note:

Wrench **P39L** ist not combined with blade R/LH100...33 - separate order required!



Einstecken und Abstecken (außen)

Grooving and Parting off (external)



Kassette

Cassette

NK100

Schnittstelle 842
Interface 842

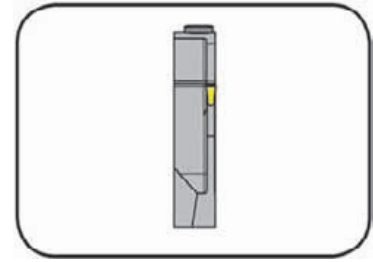

Stechtiefe	Depth of groove	34 mm
Stechbreite	Width of groove	2,5 - 4 mm

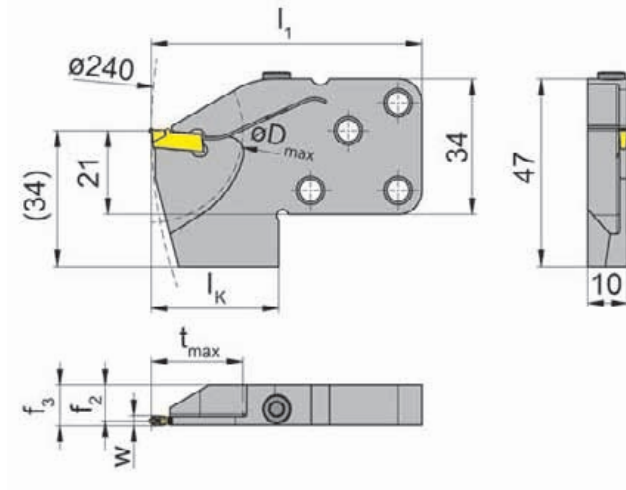

für Schneidplatte
for Insert

Typ S100...IK
Type

Kühlmittelzufuhr durch die
Schneidplatte
Coolant supply through insert

R = rechts wie gezeichnet
R = right hand version shown

L = links spiegelbildlich
L = left hand version

Bestellnummer Part number	t _{max}	f ₂	f ₃	w	l ₁	D _{max}	l _k
R/LNK100.0842.23.3.72.IK	23	8,95	f ₂ +w/2	2,5	68	46	32
R/LNK100.0842.34.3.73.IK	34	8,70	f ₂ +w/2	3,0	76	68	40
R/LNK100.0842.34.3.74.IK	34	8,20	f ₂ +w/2	4,0	76	68	40

Ausführung R oder L angeben
State R or L version

Abmessungen in mm
Dimensions in mm

Bestellhinweis:

Befestigungsschrauben der Kassetten gehören zum Lieferumfang des Stechhaltestücks.

Ordering note:

The fastening screws are combined with the grooving toolholder - no separate order required.

Das Anzugsdrehmoment der Schrauben finden Sie in den Technischen Hinweisen.

For torque specification of the screw, please see Technical Instructions.

Ersatzteile

Spare Parts

Kassette Cassette	Spannschraube Screw	TORX PLUS®-Schlüssel TORX PLUS® Wrench
R/LNK100.0842.23.3.72.IK	5.13 T20P	T20PQ

Einstechen und Abstechen

Grooving and Parting Off



Schneidplatte

Insert

S100

mit Spanformrinne
with chip former

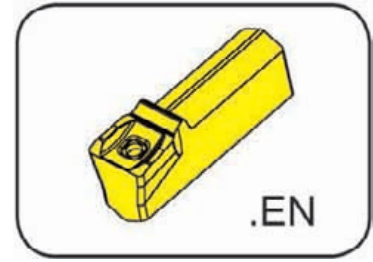

Stechbreite	Width of groove	2,5-4 mm
-------------	-----------------	----------

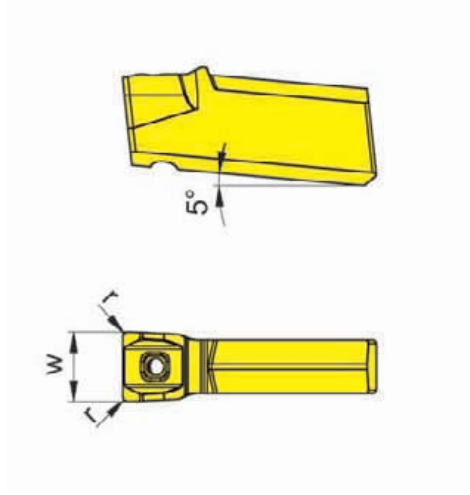

für Klemmhalter
for Toolholder

Typ H100...13/23/33/34.IK
Type NK100...IK

Kühlmittelzufuhr durch die
Schneidplatte
Coolant supply through insert

Bestellnummer Part number	w	r	Größe Size	AS45	HP65
S100.0250.EN2.IK	2,5	0,2	02	▲	▲
S100.0300.EN2.IK	3,0	0,2	03	▲	▲
S100.0400.EN3.IK	4,0	0,3	04	▲	▲
				P ●	●
				M ●	●
				K ●	●
				N ○	○
				S ●	●
				H -	-

▲ ab Lager / on stock Δ 4 Wochen / 4 weeks x auf Anfrage / upon request

● empfohlen / recommended

○ bedingt einsetzbar / alternative recommendation

- nicht geeignet / not suitable

□ unbeschichtete HM-Sorten / uncoated grades

■ beschichtete HM-Sorten / coated grades

■ bestückt/Cermet / brazed/Cermet

Abmessungen in mm

Dimensions in mm

Schneidplatten sind in **rechten und linken** Klemmhaltern verwendbar.

Indexable inserts can be used in **right and left** hand toolholders.

HM-Sorten
Carbide grades



Einstecken und Abstecken

Grooving and Parting Off



Schneidplatte

Insert

S100

mit Spanformrinne
with chip former

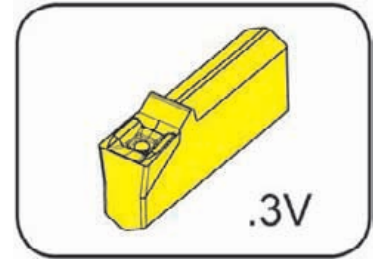

Stechbreite	Width of groove	2,5-3 mm
-------------	-----------------	----------

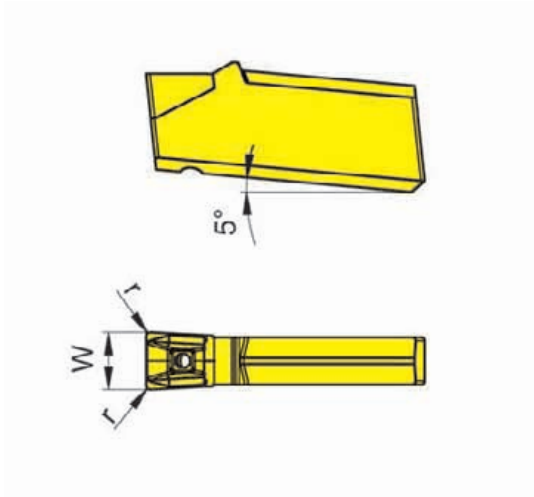

für Klemmhalter
for Toolholder

Typ H100...13/23/33/34.IK
Type NK100...IK

Kühlmittelzufuhr durch die
Schneidplatte
Coolant supply through insert

Bestellnummer Part number	w	r	Größe Size	HP65
S100.0250.3V2.IK	2,5	0,2	02	▲
S100.0300.3V2.IK	3,0	0,2	03	▲

- ▲ ab Lager / on stock Δ 4 Wochen / 4 weeks x auf Anfrage / upon request
- empfohlen / recommended
- o bedingt einsetzbar / alternative recommendation
- nicht geeignet / not suitable
- unbeschichtete HM-Sorten / uncoated grades
- beschichtete HM-Sorten / coated grades
- bestückt/Cermet / brazed/Cermet

Abmessungen in mm
Dimensions in mm

Schneidplatten sind in **rechten und linken** Klemmhaltern verwendbar.
Indexable inserts can be used in **right and left** hand toolholders.

P	●	HM-Sorten Carbide grades
M	●	
K	●	
N	○	
S	●	
H	-	

T

Möglichkeiten des Kühlmittelaustritts.
Possible coolant supply.

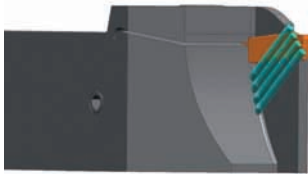

Austritt über Fächerdüsen seitlich
der Schneidplatte.

Coolant outlet through spray nozzle at the side of the insert.

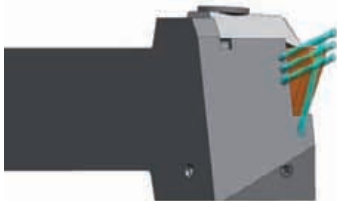

Austritt über Fächerdüsen seitlich
der Schneidplatte.

Coolant outlet through spray nozzle at the side of the insert.



S100
S224
S229

Austritt über Spannfinger.

Coolant outlet through clamping finger.

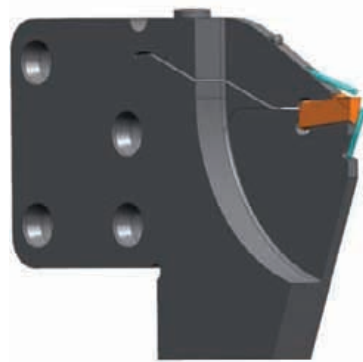

S100
S224
S229

Austritt des Kühlmittels in Kombination von Spannfinger
und Unterstüzung.

Coolant outlet through clamping finger and insert support

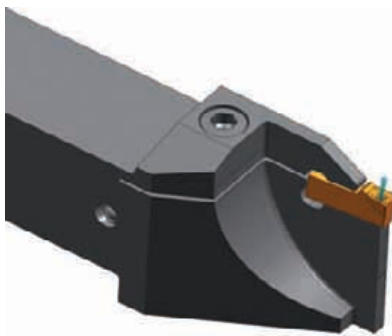

S100
S224

Austritt des KSS durch die Schneidplatte.

Coolant outlet through insert.



Klemhalter
Toolholder
H223

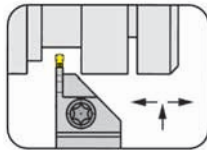

Seite/Page
T54-T55

Schneidplatte
Insert
S123

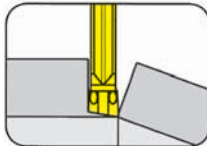

Seite/Page
T56-T57

Wendeschneidplatte
Indexable insert
S223

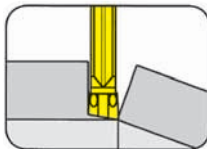

Seite/Page
T58-T59

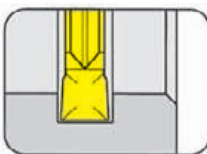

Seite/Page
T60

T

123/223



T

**Klemmhalter mit
Schneidplatten**

mit Spanformung

Stechbreite 2 - 3 mm

Stechtiefe bis 25 mm

**Toolholder with
Inserts**

with chip forming

Width of groove 2 - 3 mm

Depth of groove up to 25 mm

Klemmhalter

Toolholder

H223

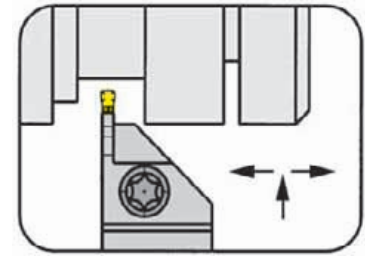

Stechtiefe bis
Stechbreite

Depth of groove up to
Width of groove

10 mm
2-3 mm

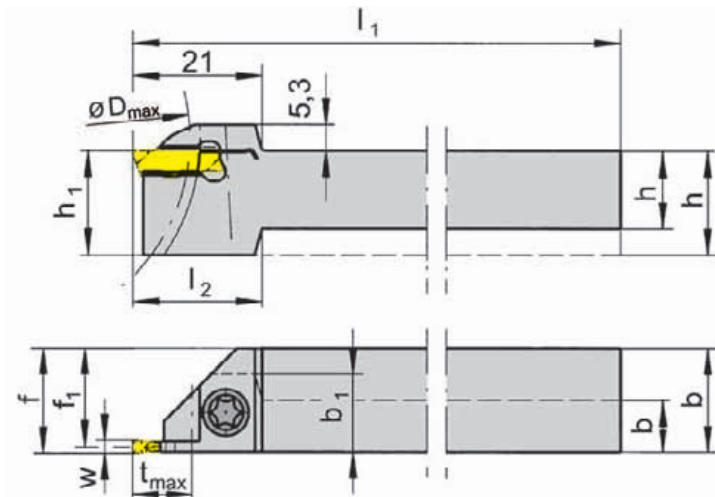

für Schneidplatte
for insert

Typ S223
Type S123

R = rechts wie gezeichnet
R = right hand version shown

L = links spiegelbildlich
L = left hand version

Bestellnummer Part number	h	b	l ₁	l ₂	h ₁	b ₁	f ₁	f	t _{max}	D _{max}	Größe Size	Spannbereich Clamping range
R/LH223.1010.01	10	10	80	20	12	12	9,20	f ₁ +w/2	8	25	01	2,0
R/LH223.1212.01	12	12	100	21	16	-	11,20	f ₁ +w/2	10	50	01	2,0
R/LH223.1616.01	16	16	125	-	16	-	15,20	f ₁ +w/2	10	50	01	2,0
R/LH223.2020.01	20	20	125	-	20	-	19,20	f ₁ +w/2	10	50	01	2,0
R/LH223.2525.01	25	25	150	-	25	-	24,20	f ₁ +w/2	10	50	01	2,0
R/LH223.1010.02	10	10	80	20	12	12	9,05	f ₁ +w/2	8	25	02	2,5
R/LH223.1212.02	12	12	100	21	16	-	11,05	f ₁ +w/2	10	50	02	2,5
R/LH223.1616.02	16	16	125	-	16	-	15,05	f ₁ +w/2	10	50	02	2,5
R/LH223.2020.02	20	20	125	-	20	-	19,05	f ₁ +w/2	10	50	02	2,5
R/LH223.2525.02	25	25	150	-	25	-	24,05	f ₁ +w/2	10	50	02	2,5
R/LH223.1010.03	10	10	80	20	12	12	8,80	f ₁ +w/2	8	25	03	3,0
R/LH223.1212.03	12	12	100	21	16	-	10,80	f ₁ +w/2	10	50	03	3,0
R/LH223.1616.03	16	16	125	-	16	-	14,80	f ₁ +w/2	10	50	03	3,0
R/LH223.2020.03	20	20	125	-	20	-	18,80	f ₁ +w/2	10	50	03	3,0
R/LH223.2525.03	25	25	150	-	25	-	23,80	f ₁ +w/2	10	50	03	3,0

Ausführung R oder L angeben
State R or L version

w siehe WSP
w see indexable inserts

Abmessungen in mm
Dimensions in mm

Weitere Abmessungen auf Anfrage
Further sizes upon request

Das Anzugsdrehmoment der Schrauben finden Sie in den Technischen Hinweisen.
For torque specification of the screw, please see Technical Instructions.

Ersatzteile

Spare Parts

Klemmhalter Toolholder	Spannschraube Screw	TORX PLUS®-Schlüssel TORX PLUS® Wrench
R/LH223...	5.11T15P	T15PL

Einstechen und Abstechen

Grooving and Parting Off



Klemmhalter

Toolholder

H223

verstärkte Ausführung
reinforced version

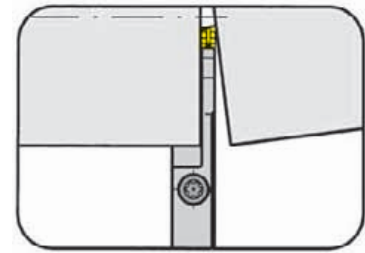

Stechtiefe bis Spannbereich	Depth of groove up to Clamping range	25 mm 2-3 mm
--------------------------------	---	-----------------

für Schneidplatte
for Insert

Typ S223
Type S123

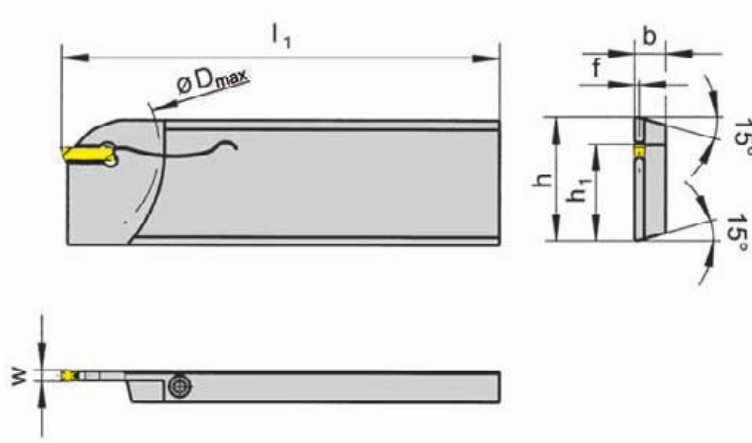

R = rechts wie gezeichnet
R = right hand version shown

L = links spiegelbildlich
L = left hand version

Bestellnummer Part number	h	b	l ₁	h ₁	f	D _{max}	Größe Size	Spannbereich Clamping range
R/LH223.2608.01	26	7,9	110	21,4	0,80	50	01	2,0
R/LH223.3208.01	32	7,9	110	24,8	0,80	50	01	2,0
R/LH223.2608.02	26	7,9	110	21,4	0,95	50	02	2,5
R/LH223.3208.02	32	7,9	110	24,8	0,95	50	02	2,5
R/LH223.2608.03	26	7,9	110	21,4	1,20	50	03	3,0
R/LH223.3208.03	32	7,9	110	24,8	1,20	50	03	3,0

Ausführung R oder L angeben
State R or L version

w siehe WSP
w see indexable inserts

Abmessungen in mm
Dimensions in mm

Weitere Abmessungen auf Anfrage
Further sizes upon request

Das Anzugsdrehmoment der Schrauben finden Sie in den Technischen Hinweisen.
For torque specification of the screw, please see Technical Instructions.

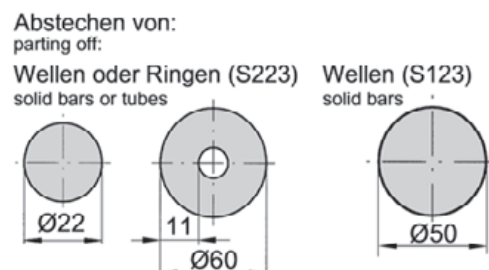

Ersatzteile

Spare Parts

Klemmhalter Toolholder	Spannschraube Screw	TORX PLUS®-Schlüssel TORX PLUS® Wrench
R/LH223...	4.15T15P	T15PL

Einstechen und Abstechen

Grooving and Parting Off



Schneidplatte

Insert

S123

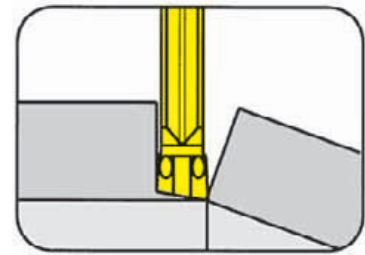

Stechtiefe bis Stechbreite	Depth of groove up to Width of groove	25,0 mm 2-3 mm
-------------------------------	--	-------------------

für Klemhalter
for Toolholder

Typ H223
Type

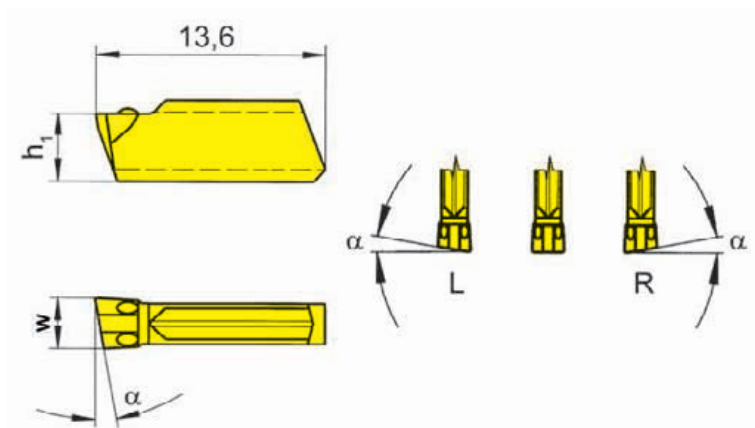

R = rechts wie gezeichnet
R = right hand version shown

L = links spiegelbildlich
L = left hand version

Bestellnummer Part number	w	α	h ₁	Größe Size	TF45	TI25	TN35
S123.0020.C0	2	0°	3,65	01	Δ	Δ	Δ
R/LS123.0420.C0	2	4°	3,65	01	Δ/Δ	Δ/Δ	Δ/Δ
R/LS123.0820.C0	2	8°	3,65	01	Δ/Δ	Δ/Δ	Δ/Δ
R/LS123.1520.C0	2	15°	3,65	01	▲/Δ	Δ/Δ	▲/Δ
S123.0030.C0	3	0°	3,95	03	Δ	Δ	Δ
R/LS123.0430.C0	3	4°	3,95	03	Δ/Δ	Δ/Δ	Δ/Δ
R/LS123.0830.C0	3	8°	3,95	03	Δ/Δ	Δ/Δ	Δ/Δ

▲ ab Lager / on stock Δ 4 Wochen / 4 weeks x auf Anfrage / upon request

● empfohlen / recommended

o bedingt einsetzbar / alternative recommendation

- nicht geeignet / not suitable

□ unbeschichtete HM-Sorten / uncoated grades

■ beschichtete HM-Sorten / coated grades

■ bestückt/Cermet / brazed/Cermet

Abmessungen in mm

Dimensions in mm

Ausführung R oder L angeben

State R or L version

Schneidplatten sind in **rechten und linken** Klemmhaltern verwendbar.

Indexable inserts can be used in **right and left** hand toolholders.

P	●	●	●
M	●	●	●
K	●	●	●
N	●	●	●
S	●	●	●
H	-	-	-

HM-Sorten
Carbide grades

Einstechen und Abstechen

Grooving and Parting Off



Schneidplatte

Insert

S123

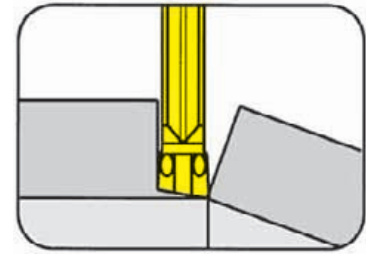

Stechtiefe bis Stechbreite	Depth of groove up to Width of groove	25,0 mm 2-3 mm
-------------------------------	--	-------------------

für Klemmhalter
for Toolholder

Typ H223
Type

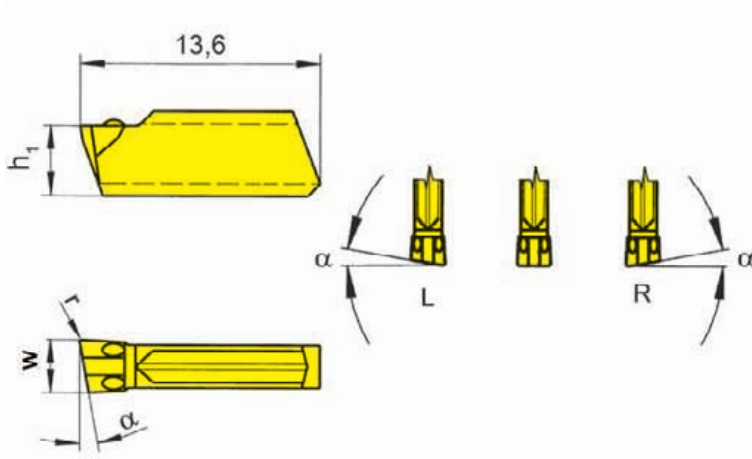

R = rechts wie gezeichnet
R = right hand version shown

L = links spiegelbildlich
L = left hand version

Bestellnummer Part number	w	r	α	h_1	Größe Size	TF45	Tl25	TN35
S123.0020.C1	2	0,15	0°	3,65	01	Δ	Δ	Δ
R/LS123.0420.C1	2	0,15	4°	3,65	01	Δ/Δ	Δ/Δ	Δ/Δ
R/LS123.0820.C1	2	0,15	8°	3,65	01	Δ/Δ	Δ/Δ	Δ/Δ
R/LS123.1520.C1	2	0,15	15°	3,65	01	Δ/Δ	Δ/Δ	Δ/Δ
S123.0030.C1	3	0,15	0°	3,95	03	Δ	Δ	Δ
R/LS123.0430.C1	3	0,15	4°	3,95	03	Δ/Δ	Δ/Δ	Δ/Δ
R/LS123.0830.C1	3	0,15	8°	3,95	03	Δ/Δ	Δ/Δ	Δ/Δ

▲ ab Lager / on stock Δ 4 Wochen / 4 weeks x auf Anfrage / upon request

● empfohlen / recommended

o bedingt einsetzbar / alternative recommendation

- nicht geeignet / not suitable

□ unbeschichtete HM-Sorten / uncoated grades

■ beschichtete HM-Sorten / coated grades

■ bestückt/Cermet / brazed/Cermet

Abmessungen in mm

Dimensions in mm

Ausführung R oder L angeben

State R or L version

Schneidplatten sind in **rechten und linken** Klemmhaltern verwendbar.

Indexable inserts can be used in **right and left** hand toolholders.

P	•	•	•
M	•	•	•
K	•	•	•
N	•	•	•
S	•	•	•
H	-	-	-

HM-Sorten
Carbide grades

T

Einstechen und Abstechen

Grooving and Parting Off



Wendeschneidplatte

Indexable insert

S223

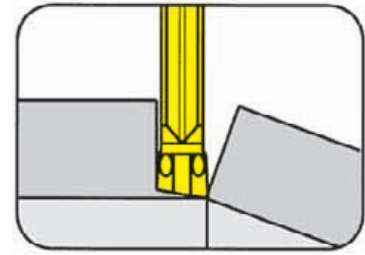

Stechtiefe bis Stechbreite	Depth of groove up to Width of groove	11,0 mm 2-3 mm
-------------------------------	--	-------------------

für Klemmhalter
for Toolholder

Typ H223
Type

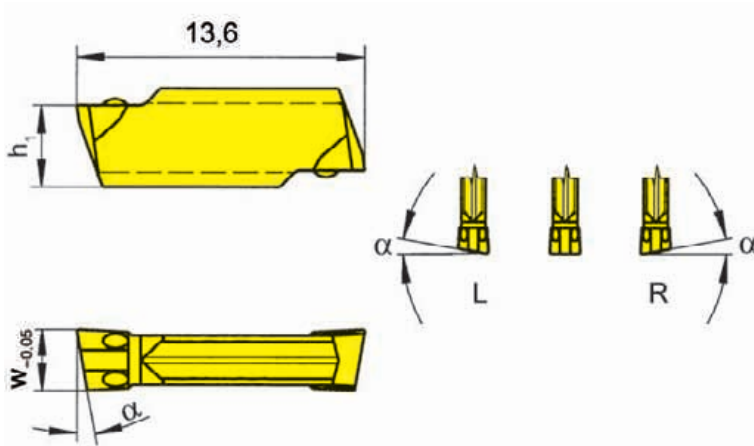

R = rechts wie gezeichnet
R = right hand version shown

L = links spiegelbildlich
L = left hand version

Bestellnummer Part number	w	α	h_1	Größe Size	TF45	TI25	TN35
S223.0020.C0	2,0	0°	3,65	01	▲	▲	▲
R/LS223.0420.C0	2,0	4°	3,65	01	▲/▲	▲/▲	▲/▲
R/LS223.0820.C0	2,0	8°	3,65	01	▲/▲	▲/▲	▲/▲
R/LS223.1520.C0	2,0	15°	3,65	01	▲/▲	▲/▲	▲/▲
S223.0025.C0	2,5	0°	3,75	02	▲	▲	▲
R/LS223.0425.C0	2,5	4°	3,75	02	▲/▲	▲/▲	▲/▲
R/LS223.0825.C0	2,5	8°	3,75	02	▲/▲	▲/▲	▲/▲
S223.0030.C0	3,0	0°	3,95	03	▲	▲	▲
R/LS223.0430.C0	3,0	4°	3,95	03	▲/▲	▲/▲	▲/▲
R/LS223.0830.C0	3,0	8°	3,95	03	▲/▲	▲/▲	▲/▲

▲ ab Lager / on stock Δ 4 Wochen / 4 weeks x auf Anfrage / upon request

● empfohlen / recommended

o bedingt einsetzbar / alternative recommendation

- nicht geeignet / not suitable

■ unbeschichtete HM-Sorten / uncoated grades

■ beschichtete HM-Sorten / coated grades

■ bestückt/Cermet / brazed/Cermet

Abmessungen in mm

Dimensions in mm

Ausführung R oder L angeben

State R or L version

Wendeschneidplatten sind in rechten und linken Klemmhaltern verwendbar.

Indexable inserts can be used in right and left hand toolholders.

P	●	●	●
M	●	●	●
K	●	●	●
N	●	●	●
S	●	●	●
H	-	-	-

HM-Sorten
Carbide grades

Einstechen und Abstechen

Grooving and Parting Off



Wendeschneidplatte

Indexable insert

S223

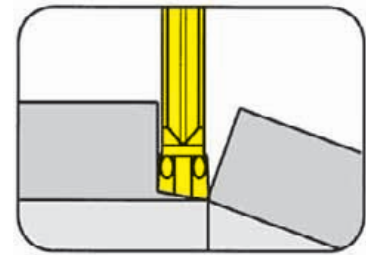

Stechtiefe bis Stechbreite	Depth of groove up to Width of groove	11,0 mm 2-3 mm
-------------------------------	--	-------------------

für Klemmhalter
for Toolholder

Typ H223
Type

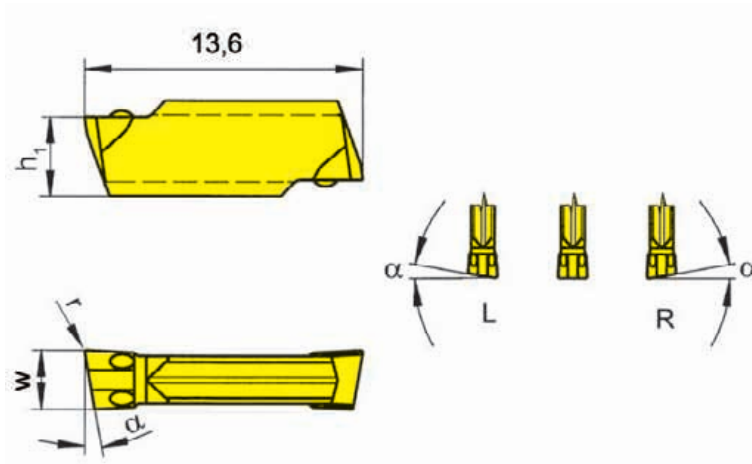

R = rechts wie gezeichnet
R = right hand version shown

L = links spiegelbildlich
L = left hand version

Bestellnummer Part number	w	r	α	h ₁	Größe Size	TF45	TI25	TN35
S223.0020.C1	2,0	0,15	0°	3,65	01	▲	▲	▲
R/LS223.0420.C1	2,0	0,15	4°	3,65	01	▲/Δ	▲/Δ	▲/Δ
R/LS223.0820.C1	2,0	0,15	8°	3,65	01	▲/Δ	▲/Δ	▲/▲
R/LS223.1520.C1	2,0	0,15	15°	3,65	01	▲/Δ	▲/Δ	▲/Δ
S223.0025.C1	2,5	0,15	0°	3,75	02	Δ	▲	Δ
R/LS223.0425.C1	2,5	0,15	4°	3,75	02	Δ/Δ	Δ/Δ	Δ/Δ
R/LS223.0825.C1	2,5	0,15	8°	3,75	02	Δ/Δ	▲/Δ	Δ/Δ
S223.0030.C1	3,0	0,15	0°	3,95	03	▲	▲	▲
R/LS223.0430.C1	3,0	0,15	4°	3,95	03	Δ/Δ	Δ/Δ	Δ/Δ
R/LS223.0830.C1	3,0	0,15	8°	3,95	03	▲/Δ	▲/Δ	▲/Δ
▲ ab Lager / on stock Δ 4 Wochen / 4 weeks x auf Anfrage / upon request						P	•	•
● empfohlen / recommended						M	•	•
o bedingt einsetzbar / alternative recommendation						K	•	•
- nicht geeignet / not suitable						N	•	•
■ unbeschichtete HM-Sorten / uncoated grades						S	•	•
■ beschichtete HM-Sorten / coated grades						H	-	-
■ bestückt/Cermet / brazed/Cermet								

Abmessungen in mm
Dimensions in mm

Ausführung R oder L angeben
State R or L version

Wendeschneidplatten sind in rechten und linken Klemmhaltern verwendbar.
Indexable inserts can be used in right and left hand toolholders.

HM-Sorten
Carbide grades



Einstechen und Abstechen

Grooving and Parting Off



Wendeschneidplatte

Indexable insert

S223

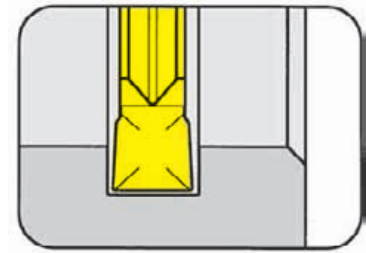

Stechtiefe bis Stechbreite	Depth of groove up to Width of groove	11,0 mm 2-3 mm
-------------------------------	--	-------------------

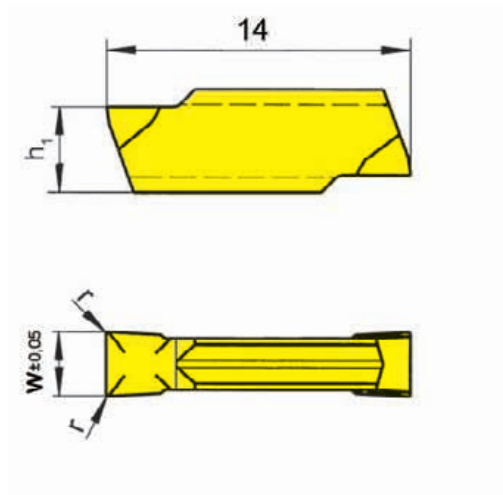

für Klemmhalter
for Toolholder

Typ H223
Type

T

Bestellnummer Part number	w	r	h ₁	Größe Size	MG12	H54	Ti25	TN35
S223.0200.32	2,0	0,2	3,65	01	▲	▲	▲	▲
S223.0250.32	2,5	0,2	3,75	02	▲	▲	▲	▲
S223.0300.32	3,0	0,2	3,95	03	▲	▲	▲	▲
					P	○	●	●
					M	●	●	●
					K	●	-	●
					N	●	-	●
					S	●	-	●
					H	-	-	-

▲ ab Lager / on stock Δ 4 Wochen / 4 weeks x auf Anfrage / upon request

● empfohlen / recommended

○ bedingt einsetzbar / alternative recommendation

- nicht geeignet / not suitable

■ unbeschichtete HM-Sorten / uncoated grades

■ beschichtete HM-Sorten / coated grades

■ bestückt/Cermet / brazed/Cermet

Abmessungen in mm

Dimensions in mm

Wendeschneidplatten sind in rechten und linken Klemmhaltern verwendbar.

Indexable inserts can be used in right and left hand toolholders.

HM-Sorten
Carbide grades



Klemmhalter
Toolholder
H224

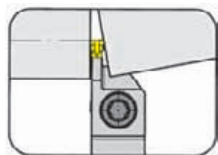

Seite/Page
T64-T71

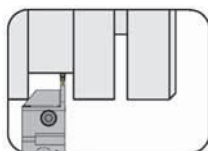

Seite/Page
T76

Wendeschneidplatte
Indexable insert
S224

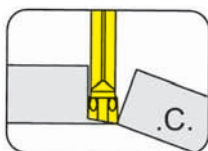

Seite/Page
T72-T73

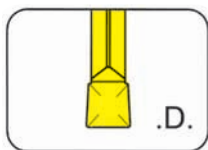

Seite/Page
T74

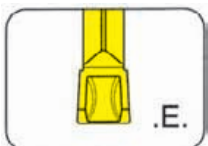

Seite/Page
T75

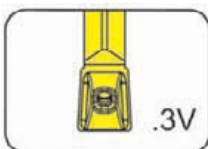

Seite/Page
T77

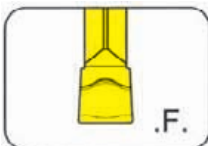

Seite/Page
T78

T

224



T

**Klemmhalter mit
Schneidplatten**

Stechbreite 2,0 - 3,0 mm

**Toolholder with
Inserts**

Width of groove 2,0 - 3,0 mm

Einstechen und Abstechen

Grooving and Parting Off



Klemmhalter

Toolholder

H224

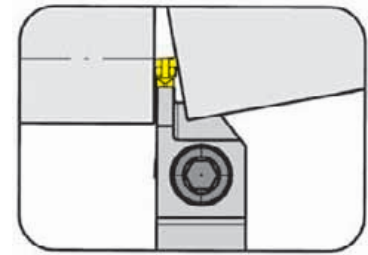

Stechtiefe bis Spannbereich	Depth of groove up to Clamping range	14 mm 2,0 - 3,7 mm
--------------------------------	---	-----------------------

für Wendeschneidplatte
for Indexable insert

Typ S224
Type

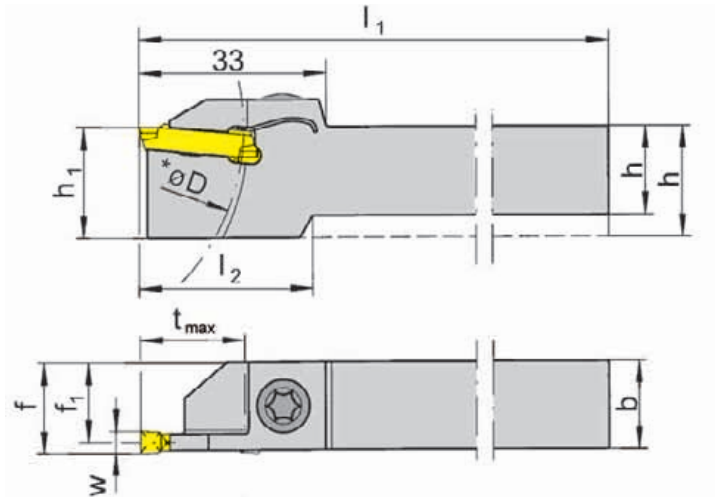

R = rechts wie gezeichnet
R = right hand version shown

L = links spiegelbildlich
L = left hand version

Bestellnummer Part number	h	b	l ₁	l ₂	h ₁	f ₁	f	t _{max}	D _{max}	Größe Size	Spannbereich Clamping range
R/LH224.1616.01	16	16	125	25	20	15,3	f ₁ +w/2	14	80	01	2,0-2,4
R/LH224.2020.01	20	20	125	-	20	19,3	f ₁ +w/2	14	80	01	2,0-2,4
R/LH224.2525.01	25	25	150	-	25	24,3	f ₁ +w/2	14	80	01	2,0-2,4
R/LH224.1616.02	16	16	125	25	20	15,1	f ₁ +w/2	14	80	02	2,4-2,8
R/LH224.2020.02	20	20	125	-	20	19,1	f ₁ +w/2	14	80	02	2,4-2,8
R/LH224.2525.02	25	25	150	-	25	24,1	f ₁ +w/2	14	80	02	2,4-2,8
R/LH224.1616.03	16	16	125	25	20	14,9	f ₁ +w/2	14	80	03	2,8-3,7
R/LH224.2020.03	20	20	125	-	20	18,9	f ₁ +w/2	14	80	03	2,8-3,7
R/LH224.2525.03	25	25	150	-	25	23,9	f ₁ +w/2	14	80	03	2,8-3,7

Ausführung R oder L angeben
State R or L version

w siehe WSP
w see indexable inserts

Abmessungen in mm
Dimensions in mm

Weitere Abmessungen auf Anfrage
Further sizes upon request

* t_{max} bis D = 80 mm

* t_{max} up to D = 80 mm

Das Anzugsdrehmoment der Schrauben finden Sie in den Technischen Hinweisen.
For torque specification of the screw, please see Technical Instructions.

Ersatzteile

Spare Parts

Klemmhalter Toolholder	Spannschraube Screw	TORX PLUS®-Schlüssel TORX PLUS® Wrench
R/LH224...	6.23T25P	T25PQ

Einstechen und Abstechen

Grooving and Parting Off



Klemmhalter

Toolholder

H224

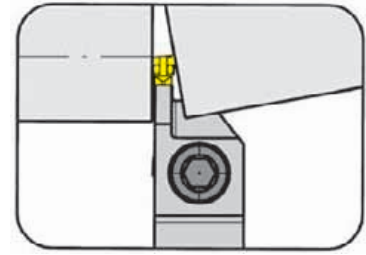

Stechtiefe bis Spannbereich	Depth of groove up to Clamping range	18 mm 2,0 - 3,7 mm
--------------------------------	---	-----------------------

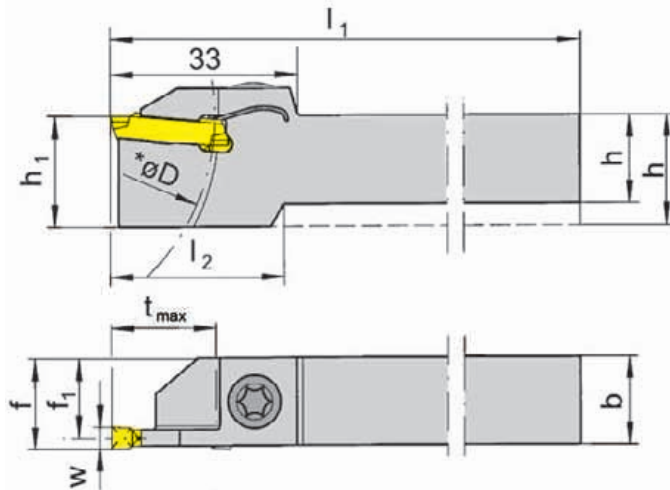

für Wendeschneidplatte
for Indexable insert

Typ S224
Type

R = rechts wie gezeichnet
R = right hand version shown

L = links spiegelbildlich
L = left hand version

Bestellnummer Part number	h	b	l ₁	l ₂	h ₁	f ₁	f	t _{max}	D _{max}	Größe Size	Spannbereich Clamping range
R/LH224.1616.21	16	16	125	30	20	15,3	f ₁ +w/2	18	80	01	2,0-2,4
R/LH224.2020.21	20	20	125	-	20	19,3	f ₁ +w/2	18	80	01	2,0-2,4
R/LH224.2525.21	25	25	150	-	25	24,3	f ₁ +w/2	18	80	01	2,0-2,4
R/LH224.1616.22	16	16	125	30	20	15,1	f ₁ +w/2	18	80	02	2,4-2,8
R/LH224.2020.22	20	20	125	-	20	19,1	f ₁ +w/2	18	80	02	2,4-2,8
R/LH224.2525.22	25	25	150	-	25	24,1	f ₁ +w/2	18	80	02	2,4-2,8
R/LH224.1608.23	16	8	100	-	20	6,9	f ₁ +w/2	18	80	03	2,8-3,7
R/LH224.1616.23	16	16	125	30	20	14,9	f ₁ +w/2	18	80	03	2,8-3,7
R/LH224.2020.23	20	20	125	-	20	18,9	f ₁ +w/2	18	80	03	2,8-3,7
R/LH224.2525.23	25	25	150	-	25	23,9	f ₁ +w/2	18	80	03	2,8-3,7

Ausführung R oder L angeben
State R or L version

w siehe WSP
w see indexable inserts

Abmessungen in mm
Dimensions in mm

Weitere Abmessungen auf Anfrage

Further sizes upon request

* t_{max} bis D = 80 mm

* t_{max} up to D = 80 mm

Das Anzugsdrehmoment der Schrauben finden Sie in den Technischen Hinweisen.

For torque specification of the screw, please see Technical Instructions.

Ersatzteile

Spare Parts

Klemmhalter Toolholder	Spannschraube Screw	TORX PLUS®-Schlüssel TORX PLUS® Wrench
R/LH224...	6.23T25P	T25PQ
R/LH224.1608.23	4.15T15P	T15PQ

Einstechen und Abstechen

Grooving and Parting Off



Klemmhalter

Toolholder

H224

mit Selbstklemmung
with self clamping

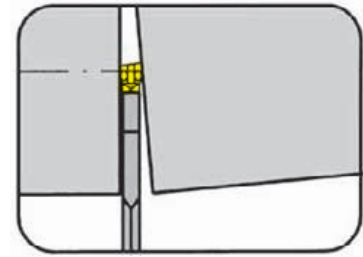

Stechtiefe bis Spannbereich	Depth of groove up to Clamping range	18 mm 2,0 - 3,7 mm
--------------------------------	---	-----------------------

für Wendeschneidplatte
for Indexable insert

Typ S224
Type

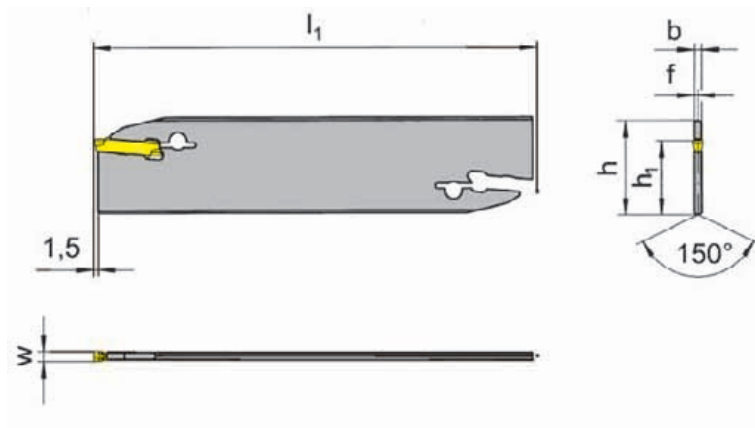

Bestellnummer Part number	h	b	l ₁	h ₁	f	t _{max}	Größe Size	Spannbereich Clamping range
H224.2602.02	26	1,9	110	21,4	0,95	18	02	2,4-2,8
H224.2603.03	26	2,3	110	21,4	1,15	18	03	2,8-3,7
H224.3203.03	32	2,3	150	24,8	1,15	18	03	2,8-3,7

Weitere Abmessungen auf Anfrage
Further sizes upon request

w siehe WSP
w see indexable inserts

Abmessungen in mm
Dimensions in mm

Hinweis:

Der Schlüssel **P39L** gehört nicht zum Lieferumfang des Schneidträgers R/LH100...33. Bitte separat bestellen!

Note:

Wrench **P39L** is not combined with blade R/LH100...33 - separate order required!

T

Einstechen und Abstechen

Grooving and Parting Off



Klemmhalter

Toolholder

H224

verstärkte Ausführung
reinforced version

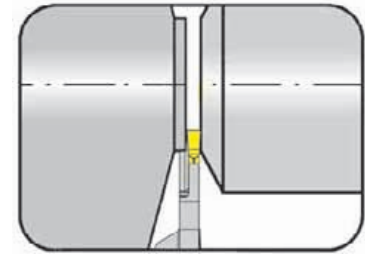

Stechtiefe bis Stechbreite	Depth of groove up to Width of groove	11 mm 2 - 3 mm
-------------------------------	--	-------------------

für TRAUB-Maschinen (TNL18P)
for machines TRAUB (TNL18P)

für Wendeschneidplatte
for Indexable insert

Typ S224
Type

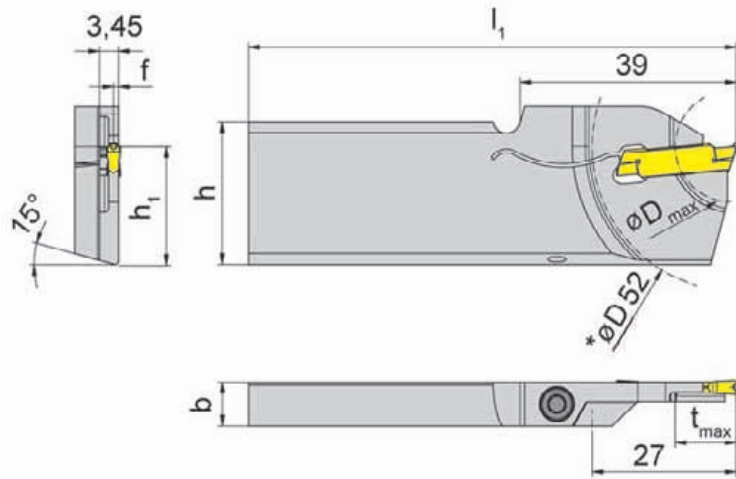

L = Linksausführung
L = left hand version

Bestellnummer Part number	h	b	l ₁	h ₁	f	t _{max}	D _{max}	Größe Size	Spannbereich Clamping range
LH224.2608.20.T.81	26	7,9	88	21,4	0,7	11	20	01	2,0
LH224.2608.20.T.82	26	7,9	88	21,4	0,9	11	20	02	2,5
LH224.2608.20.T.83	26	7,9	88	21,4	1,1	11	20	03	3,0

Weitere Abmessungen auf Anfrage
Further sizes upon request

* D 52 = D_{max} der Gegenspindel
* D 52 = D_{max} of the subspindle

Abmessungen in mm
Dimensions in mm

Das Anzugsdrehmoment der Schrauben finden Sie in den Technischen Hinweisen.
For torque specification of the screw, please see Technical Instructions.

Ersatzteile

Spare Parts

Klemmhalter Toolholder	Spannschraube Screw	TORX PLUS®-Schlüssel TORX PLUS® Wrench
LH224...	4.15T15P	T15PQ

Einstechen und Abstechen

Grooving and Parting Off



Klemmhalter

Toolholder

H224

verstärkte Ausführung
reinforced version

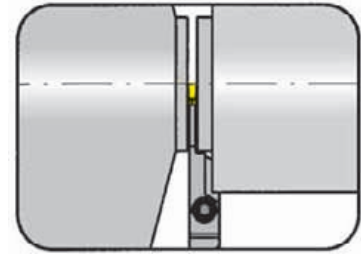

Stechtiefe bis Spannbereich	Depth of groove up to Clamping range	18 mm 2,4 - 3,7 mm
--------------------------------	---	-----------------------

für TRAUB-Maschinen (TNK28/TNK36/TNL26)
for machines TRAUB (TNK28/TNK36/TNL26)

für Wendeschneidplatte
for Indexable insert

Typ S224
Type

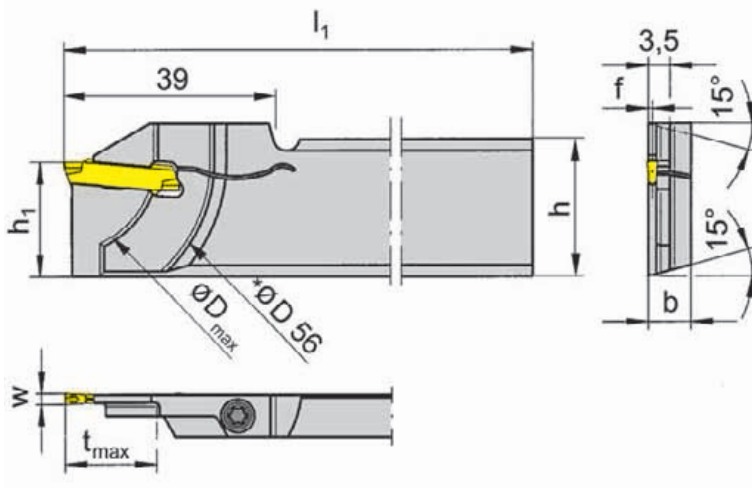

R = rechts wie gezeichnet
R = right hand version shown

L = links spiegelbildlich
L = left hand version

Bestellnummer Part number	h	b	l ₁	h ₁	f	t _{max}	D _{max}	Größe Size	Spannbereich Clamping range
R/LH224.2608.81	26	7,9	110	21,4	0,75	18	36	01	2,0-2,4
R/LH224.2608.82	26	7,9	110	21,4	0,95	18	36	02	2,4-2,8
R/LH224.2608.83	26	7,9	110	21,4	1,10	18	36	03	2,8-3,7

Ausführung R oder L angeben
State R or L version

w siehe WSP
w see indexable inserts

Abmessungen in mm
Dimensions in mm

*D 56 = D_{max} der Gegenspindel
*D 56 = D_{max} of the subspindle

Weitere Abmessungen auf Anfrage
Further sizes upon request

Das Anzugsdrehmoment der Schrauben finden Sie in den Technischen Hinweisen.
For torque specification of the screw, please see Technical Instructions.

Ersatzteile

Spare Parts

Klemmhalter Toolholder	Spannschraube Screw	TORX PLUS®-Schlüssel TORX PLUS® Wrench
R/LH224.2608....	4.15T15P	T15PQ

Einstechen und Abstechen

Grooving and Parting Off



Klemmhalter

Toolholder

H224

verstärkte Ausführung
reinforced version

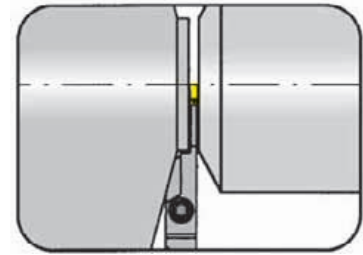

Stechtiefe bis Spannbereich	Depth of groove up to Clamping range	21 mm 2,0 - 3,7 mm
--------------------------------	---	-----------------------

für TRAUB-Maschinen (TNK28/TNK36/TNL26)
for machines TRAUB (TNK28/TNK36/TNL26)

für Wendeschneidplatte
for Indexable insert

Typ S224
Type

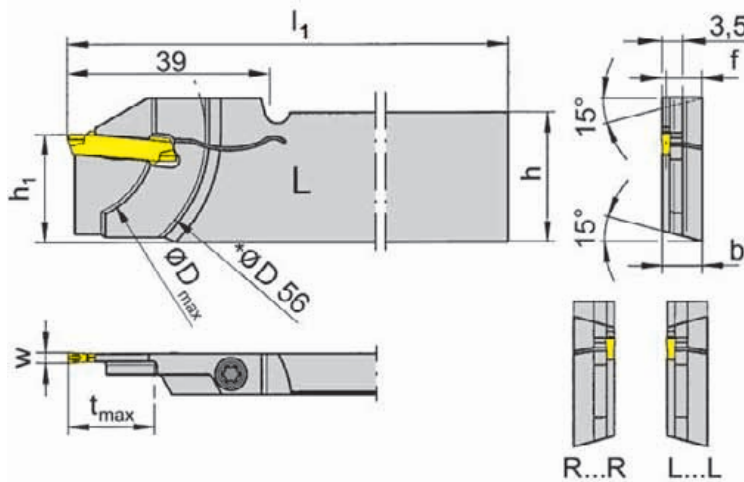

L = links wie gezeichnet
L = left hand version shown

R = rechts spiegelbildlich
R = right hand version

Bestellnummer Part number	h	b	l ₁	h ₁	f	t _{max}	D _{max}	Größe Size	Spannbereich Clamping range
LH224.2608.81L	26	7,9	110	21,4	7,15	18	36	01	2,0-2,4
RH224.2608.81R	26	7,9	110	21,4	7,15	18	36	01	2,0-2,4
LH224.2608.82L	26	7,9	110	21,4	6,95	18	36	02	2,4-2,8
RH224.2608.82R	26	7,9	110	21,4	6,95	18	36	02	2,4-2,8
LH224.2608.83L	26	7,9	110	21,4	6,75	18	36	03	2,8-3,7
RH224.2608.83R	26	7,9	110	21,4	6,75	18	36	03	2,8-3,7
RH224.3208.83R	32	7,9	110	24,8	6,80	21	42	03	2,8-3,7

Ausführung R oder L angeben
State R or L version

w siehe WSP
w see indexable inserts

Abmessungen in mm
Dimensions in mm

Weitere Abmessungen auf Anfrage
Further sizes upon request

*D 56 = D_{max} der Gegenspindel

*D 56 = D_{max} of the subspindle

* Bei besonderer Spannsituation auf der Gegenspindel (z.B. HAINBUCH Axfixfutter usw.)

* For specific clamping device on subspindle (e.g. HAINBUCH Axfixchuck)

Das Anzugsdrehmoment der Schrauben finden Sie in den Technischen Hinweisen.

For torque specification of the screw, please see Technical Instructions.

Ersatzteile

Spare Parts

Klemmhalter Toolholder	Spannschraube Screw	TORX PLUS®-Schlüssel TORX PLUS® Wrench
R/LH224...	4.15T15P	T15PL
R/LH224.3208.83R/L	5.13 T20P	T20PQ

Einstechen und Abstechen

Grooving and Parting Off



Klemmhalter

Toolholder

H224

verstärkte Ausführung
reinforced version

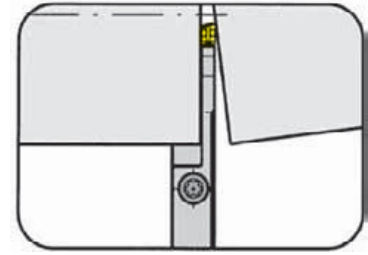

Stechtiefe bis Spannbereich	Depth of groove up to Clamping range	18 mm 2,0 - 3,7 mm
--------------------------------	---	-----------------------

für Wendeschneidplatte
for Indexable insert

Typ S224
Type

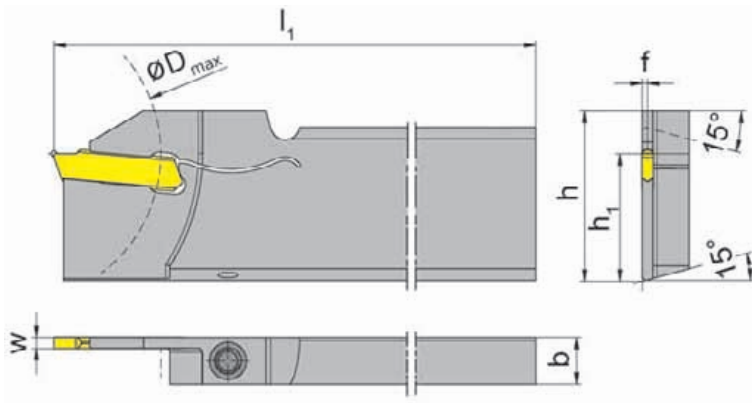

R = rechts wie gezeichnet
R = right hand version shown

L = links spiegelbildlich
L = left hand version

Bestellnummer Part number	h	b	l ₁	h ₁	f	t _{max}	D _{max}	Größe Size	Spannbereich Clamping range
R/LH224.2608.01	26	7,9	110	21,4	0,7	18	50	01	2,0-2,4
R/LH224.3208.01	32	7,9	110	24,8	0,7	18	50	01	2,0-2,4
R/LH224.2608.02	26	7,9	110	21,4	0,9	18	50	02	2,4-2,8
R/LH224.3208.02	32	7,9	110	24,8	0,9	18	50	02	2,4-2,8
R/LH224.2608.03	26	7,9	110	21,4	1,1	18	50	03	2,8-3,7
R/LH224.3208.03	32	7,9	110	24,8	1,1	18	50	03	2,8-3,7

Ausführung R oder L angeben
State R or L version

w siehe WSP
w see indexable inserts

Abmessungen in mm
Dimensions in mm

Weitere Abmessungen auf Anfrage
Further sizes upon request

Das Anzugsdrehmoment der Schrauben finden Sie in den Technischen Hinweisen.
For torque specification of the screw, please see Technical Instructions.

Abstechen von Wellen
parting off solid bars

Abstechen von Ringen
parting off tubes

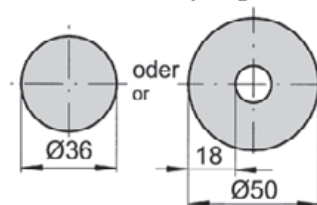

Ersatzteile

Spare Parts

Klemmhalter Toolholder	Spannschraube Screw	TORX PLUS®-Schlüssel TORX PLUS® Wrench
R/LH224...	4.20T15P	T15PQ

Einstechen und Abstechen

Grooving and Parting Off



Klemmhalter

Toolholder

H224

mit Schraubklemmung
with screwed clamping

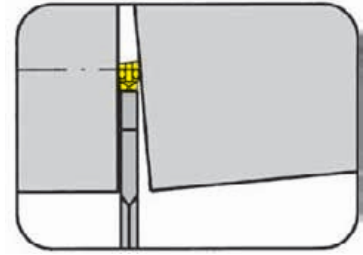

Stechtiefe bis Spannbereich	Depth of groove up to Clamping range	32,5 mm 2,8 - 3,7 mm
--------------------------------	---	-------------------------

für Wendeschneidplatte
for Indexable insert

Typ S224
Type

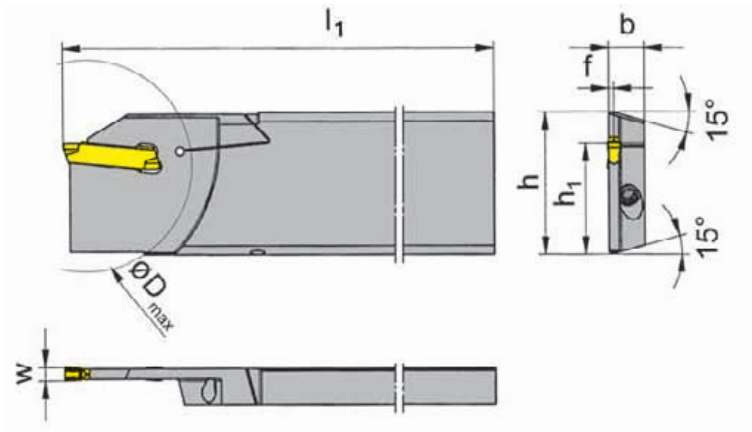

R = rechts wie gezeichnet
R = right hand version shown

L = links spiegelbildlich
L = left hand version

Bestellnummer Part number	h	b	l ₁	h ₁	f	t _{max}	D _{max}	Größe Size	Spannbereich Clamping range
R/LH224.3208.93	32	8	112	24,8	1,15	32,5	65	03	2,8-3,7

Ausführung R oder L angeben
State R or L version

w siehe WSP
w see indexable inserts

Abmessungen in mm
Dimensions in mm

Weitere Abmessungen auf Anfrage
Further sizes upon request

Das Anzugsdrehmoment der Schrauben finden Sie in den Technischen Hinweisen.
For torque specification of the screw, please see Technical Instructions.

Ersatzteile

Spare Parts

Klemmhalter Toolholder	Spannschraube Screw	TORX PLUS®-Schlüssel TORX PLUS® Wrench
R/LH224.3208.93	030.0413.T15P	T15PQ



Einstechen und Abstechen

Grooving and Parting Off



Wendeschneidplatte

Indexable insert

S224

mit Spanformung
with chip forming

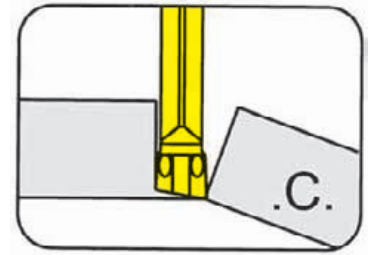

Stechtiefe bis Stechbreite	Depth of groove up to Width of groove	18 mm 2-3 mm
-------------------------------	--	-----------------

präzisionsgesintert
precision sintered

für Klemmhalter
for Toolholder

Typ H224
Type

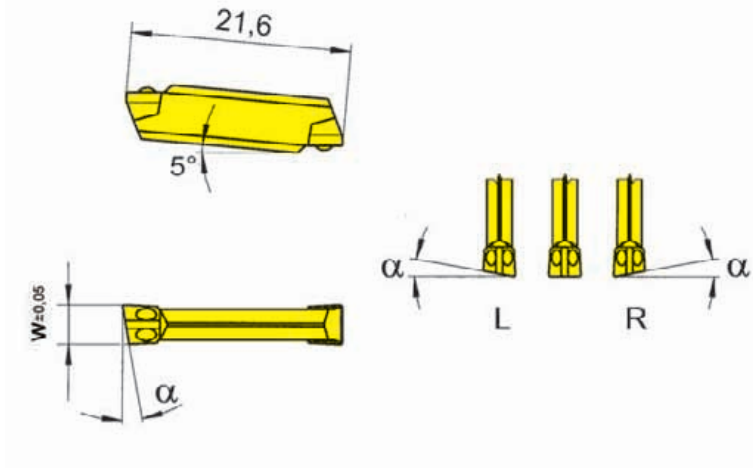

R = rechts wie gezeichnet
R = right hand version shown

L = links spiegelbildlich
L = left hand version

Bestellnummer Part number	w	α	Größe Size	HM-Sorten Carbide grades			
				TC92	TF45	TI25	TN35
S224.0020.C0	2,0	0°	01	Δ	▲	▲	▲
R/LS224.0520.C0	2,0	5°	01	Δ/Δ	▲/Δ	Δ/Δ	▲/▲
R/LS224.0820.C0	2,0	8°	01	Δ/Δ	▲/▲	Δ/Δ	▲/▲
R/L/S224.1520.C0	2,0	15°	01	Δ/Δ	▲/▲	x/x	▲/▲
S224.0025.C0	2,5	0°	02	Δ	▲	▲	▲
R/LS224.0525.C0	2,5	5°	02	Δ/Δ	▲/Δ	▲/Δ	▲/▲
R/L/S224.0825.C0	2,5	8°	02	Δ/Δ	Δ/Δ	Δ/x	▲/▲
S224.0030.C0	3,0	0°	03	Δ	▲	▲	▲
R/LS224.0530.C0	3,0	5°	03	▲/Δ	▲/Δ	Δ/Δ	▲/▲
R/L/S224.0830.C0	3,0	8°	03	Δ/Δ	▲/▲	x/x	▲/▲

▲ ab Lager / on stock Δ 4 Wochen / 4 weeks x auf Anfrage / upon request

● empfohlen / recommended

o bedingt einsetzbar / alternative recommendation

- nicht geeignet / not suitable

■ unbeschichtete HM-Sorten / uncoated grades

■ beschichtete HM-Sorten / coated grades

■ bestückt/Cermet / brazed/Cermet

Abmessungen in mm

Dimensions in mm

Ausführung R oder L angeben

State R or L version

Weitere Abmessungen auf Anfrage

Further sizes upon request

Wendeschneidplatten sind in rechten und linken Klemmhaltern verwendbar.

Indexable inserts can be used in right and left hand toolholders.

P	●	●	●	●
M	-	●	●	●
K	-	●	●	●
N	-	●	●	●
S	-	●	●	●
H	-	-	-	-

HM-Sorten
Carbide grades

Einstechen und Abstechen

Grooving and Parting Off



Wendeschneidplatte

Indexable insert

S224

mit Spanformung
with chip forming

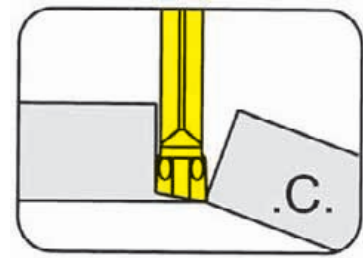

Stechtiefe bis Stechbreite	Depth of groove up to Width of groove	18 mm 2-3 mm
-------------------------------	--	-----------------

präzisionsgesintert
precision sintered

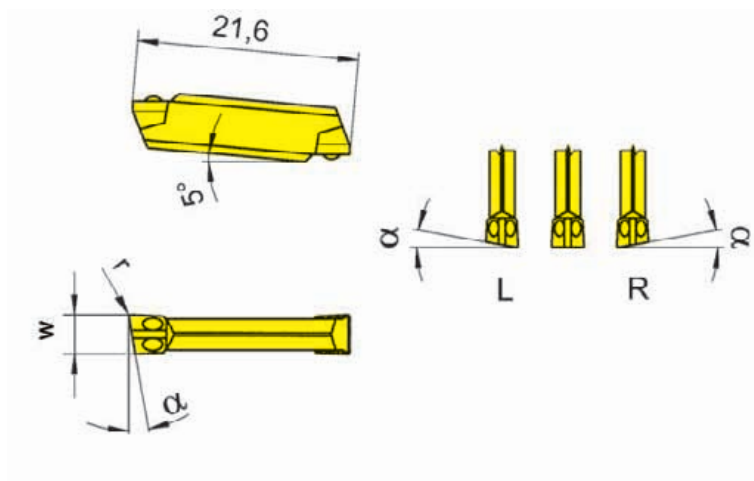

für Klemmhalter
for Toolholder

Typ H224
Type

R = rechts wie gezeichnet
R = right hand version shown

L = links spiegelbildlich
L = left hand version

Bestellnummer Part number	w	r	α	Größe Size	TC92	TF45	TI25	TN35
S224.0020.C1	2,0	0,15	0°	01	▲	▲	▲	▲
R/LS224.0520.C1	2,0	0,15	5°	01	▲/▲	▲/▲		▲/▲
R/LS224.0820.C1	2,0	0,15	8°	01	▲/▲	▲/▲		▲/▲
R/LS224.1520.C1	2,0	0,15	15°	01	▲/▲	▲/▲		▲/▲
S224.0025.C1	2,5	0,15	0°	02	▲	▲	▲	▲
R/LS224.0525.C1	2,5	0,15	5°	02	▲/▲	▲/▲		▲/▲
R/LS224.0825.C1	2,5	0,15	8°	02	▲/▲	▲/▲		▲/▲
S224.0030.C1	3,0	0,15	0°	03	▲	▲	▲	▲
R/LS224.0530.C1	3,0	0,15	5°	03	▲/▲	▲/▲		▲/▲
R/LS224.0830.C1	3,0	0,15	8°	03	▲/▲	▲/▲		▲/▲

▲ ab Lager / on stock Δ 4 Wochen / 4 weeks x auf Anfrage / upon request

● empfohlen / recommended

o bedingt einsetzbar / alternative recommendation

- nicht geeignet / not suitable

unbeschichtete HM-Sorten / uncoated grades

beschichtete HM-Sorten / coated grades

bestückt/Cermet / brazed/Cermet

Abmessungen in mm

Dimensions in mm

Ausführung R oder L angeben

State R or L version

Weitere Abmessungen auf Anfrage

Further sizes upon request

Wendeschneidplatten sind in rechten und linken Klemmhaltern verwendbar.

Indexable inserts can be used in right and left hand toolholders.

P	●	●	●	●
M	-	●	●	●
K	-	●	●	●
N	-	●	●	●
S	-	●	●	●
H	-	-	-	-

HM-Sorten
Carbide grades

T

Einstechen und Abstechen

Grooving and Parting Off



Wendeschneidplatte

Indexable insert

S224

mit Spanformung
with chip forming

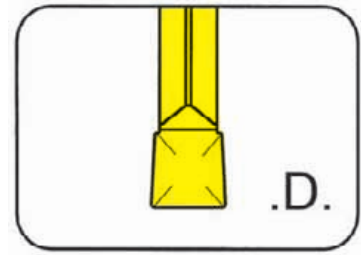

Stechtiefe bis Stechbreite	Depth of groove up to Width of groove	18 mm 2-3 mm
-------------------------------	--	-----------------

präzisionsgesintert
precision sintered

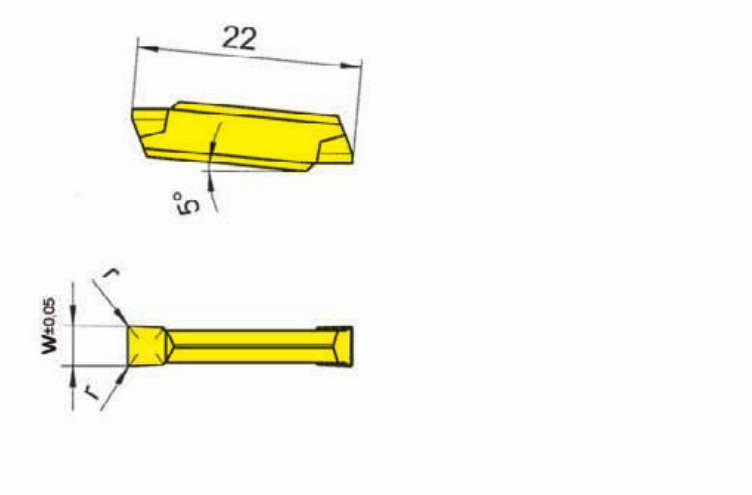

für Klemmhalter
for Toolholder

Typ H224
Type

Wechselgenauigkeit
Länge ± 0,06 mm
Indexability length ± 0,06 mm

T

Bestellnummer Part number	w	r	Größe Size	H54	TF45	TF46	TI25	TN32	TN35
S224.0200.D2	2,0	0,2	01	▲	▲	▲	▲	▲	▲
S224.0250.D2	2,5	0,2	02	△	▲	▲	▲	▲	▲
S224.0300.D2	3,0	0,2	03	▲	▲	▲	▲	▲	▲
▲ ab Lager / on stock Δ 4 Wochen / 4 weeks x auf Anfrage / upon request				P	●	●	●	●	●
● empfohlen / recommended				M	●	●	○	●	●
○ bedingt einsetzbar / alternative recommendation				K	-	●	●	-	●
- nicht geeignet / not suitable				N	-	●	●	-	●
■ unbeschichtete HM-Sorten / uncoated grades				S	-	●	○	-	●
■ beschichtete HM-Sorten / coated grades				H	-	-	-	-	-
■ bestückt/Cermet / brazed/Cermet									

Abmessungen in mm
Dimensions in mm

Wendeschneidplatten sind in rechten und linken Klemmhaltern verwendbar.
Indexable inserts can be used in right and left hand toolholders.

HM-Sorten
Carbide grades

Einstechen und Abstechen

Grooving and Parting Off



Wendeschneidplatte

Indexable insert

S224

mit Spanformrinne
with chip former

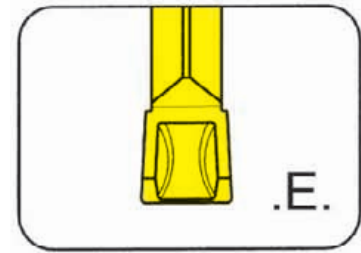

Stechtiefe bis Stechbreite	Depth of groove up to Width of groove	18 mm 2-3 mm
-------------------------------	--	-----------------

präzisionsgesintert
precision sintered

für Klemmhalter
for Toolholder

Typ H224
Type

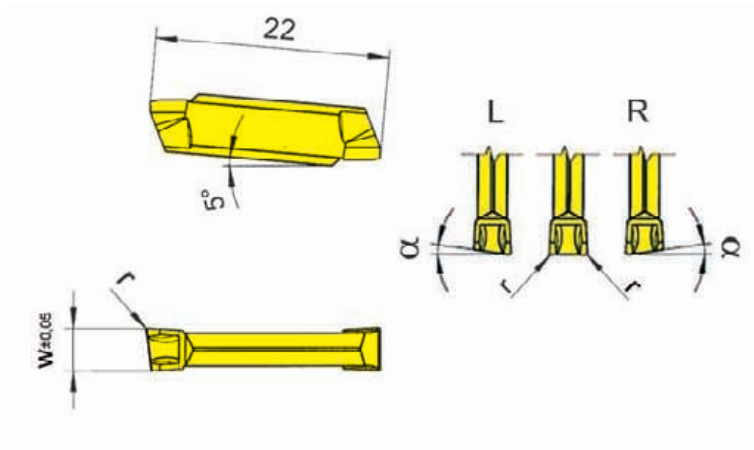

R = rechts wie gezeichnet
R = right hand version shown

L = links spiegelbildlich
L = left hand version

Bestellnummer Part number	w	r	α	Größe Size	AL96	AS62	TA43	TC92	TC93	TF43	TF45	TI22	TI25	TN32	TN35
S224.0200.E2	2,0	0,2	0°	01		▲		Δ	Δ	▲	▲				
R/LS224.0520.E2	2,0	0,2	5°	01		▲/▲		Δ/Δ	Δ/Δ	Δ/Δ	x/Δ				
S224.0250.E2	2,5	0,2	0°	02		▲		▲	Δ	▲	▲				
R/LS224.0525.E2	2,5	0,2	5°	02		▲/Δ		Δ/Δ	Δ/Δ	Δ/Δ	Δ/Δ				
S224.0300.E2	3,0	0,2	0°	03	Δ	▲	Δ	▲	Δ	▲	▲	▲	▲	Δ	Δ
S224.0300.E4	3,0	0,4	0°	03	Δ	▲		Δ	Δ	▲	▲		Δ	Δ	Δ
R/LS224.0530.E2	3,0	0,2	5°	03		▲/▲		Δ/Δ	Δ/Δ	▲/Δ	▲/▲				
					P	●	●	●	●	●	●	●	●	●	●
					M	-	-	-	-	-	-	-	-	-	-
					K	●	-	-	-	-	-	-	-	-	-
					N	●	-	-	-	-	●	-	●	-	●
					S	-	-	-	-	-	●	-	●	-	●
					H	-	-	-	-	-	-	-	-	-	-

- ▲ ab Lager / on stock Δ 4 Wochen / 4 weeks x auf Anfrage / upon request
- empfohlen / recommended
- bedingt einsetzbar / alternative recommendation
- nicht geeignet / not suitable
- unbeschichtete HM-Sorten / uncoated grades
- beschichtete HM-Sorten / coated grades
- bestückt/Cermet / brazed/Cermet

Abmessungen in mm
Dimensions in mm

Ausführung R oder L angeben
State R or L version

Weitere Abmessungen auf Anfrage
Further sizes upon request

Wendeschneidplatten sind in rechten und linken Klemmhaltern verwendbar.
Indexable inserts can be used in right and left hand toolholders.

HM-Sorten
Carbide grades



Einstechen und Abstechen

Grooving and Parting Off



Klemmhalter

Toolholder

H224

mit Schraubklemmung
with screwed clamping

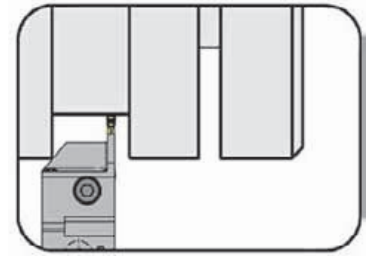

Stechtiefe bis Stechbreite	Depth of groove up to Width of groove	18 mm 3 mm
-------------------------------	--	---------------

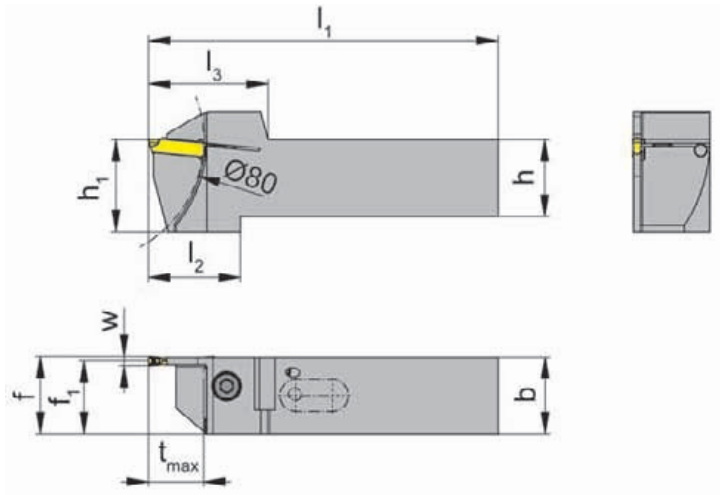

für Wendeschneidplatte
for Indexable insert

Typ S224
Type

Kühlmittelzufuhr durch die
Schneidplatte
Coolant supply through insert

L = links wie gezeichnet
L = left hand version shown

R = rechts spiegelbildlich
R = right hand version

Bestellnummer Part number	h	b	l ₁	l ₂	l ₃	h ₁	f ₁	f	t _{max}	Größe Size
RH224.1616.3.23.IK	16	16	87	33	39	25	14,75	f ₁ +w/2	18	03
RH224.2020.3.23.IK	20	20	99	30	39	25	18,75	f ₁ +w/2	18	03
RH224.2525.3.23.IK	25	25	114	30	39	30	23,75	f ₁ +w/2	18	03

Ausführung R oder L angeben
State R or L version

w siehe WSP
w see indexable inserts

Abmessungen in mm
Dimensions in mm

Weitere Abmessungen auf Anfrage
Further sizes upon request

Das Anzugsdrehmoment der Schraube 6.23T25P beträgt 6 Nm.
Torque specification of the screw 6.23T25P = 6 Nm.

Ersatzteile

Spare Parts

Klemmhalter Toolholder	Spannschraube Screw	TORX PLUS®-Schlüssel TORX PLUS® Wrench
RH224...	6.23T25P	T25PQ

Einstechen und Abstechen

Grooving and Parting Off



Wendeschneidplatte

Indexable insert

S224

mit Spanformrille
with chip former

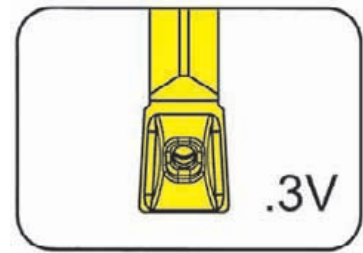

Stechbreite	Width of groove	3 mm
-------------	-----------------	------

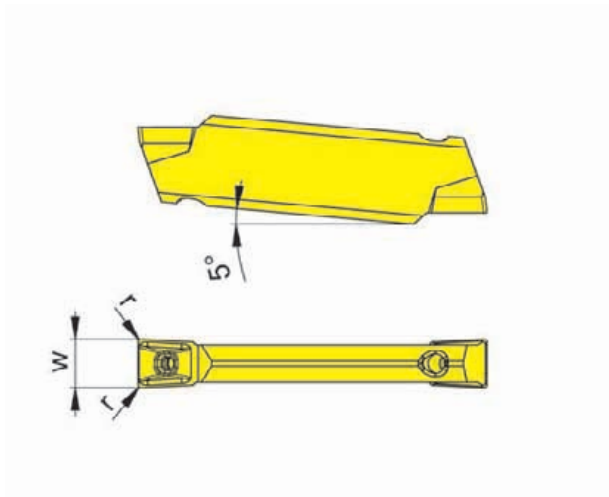

für Klemmhalter
for Toolholder

Typ H224...IK
Type

Kühlmittelzufuhr durch die
Schneidplatte
Coolant supply through insert

Bestellnummer Part number	w	r	Größe Size	HP65
S224.0300.3V2.IK	3	0,2	03	▲
				P ●
				M ●
				K ●
				N ○
				S ●
				H -

- ▲ ab Lager / on stock Δ 4 Wochen / 4 weeks x auf Anfrage / upon request
- empfohlen / recommended
- bedingt einsetzbar / alternative recommendation
- nicht geeignet / not suitable
- unbeschichtete HM-Sorten / uncoated grades
- beschichtete HM-Sorten / coated grades
- bestückt/Cermet / brazed/Cermet

Abmessungen in mm
Dimensions in mm

Wendeschneidplatten sind in rechten und linken Klemmhaltern verwendbar.
Indexable inserts can be used in right and left hand toolholders.

HM-Sorten
Carbide grades



Einstechen und Abstechen

Grooving and Parting Off



Wendeschneidplatte

Indexable insert

S224

mit Spanformung
with chip forming

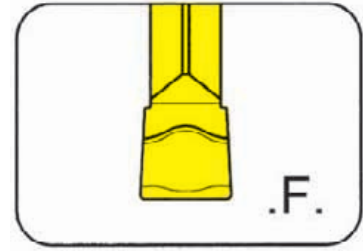

Stechtiefe bis Stechbreite	Depth of groove up to Width of groove	18 mm 2-3 mm
-------------------------------	--	-----------------

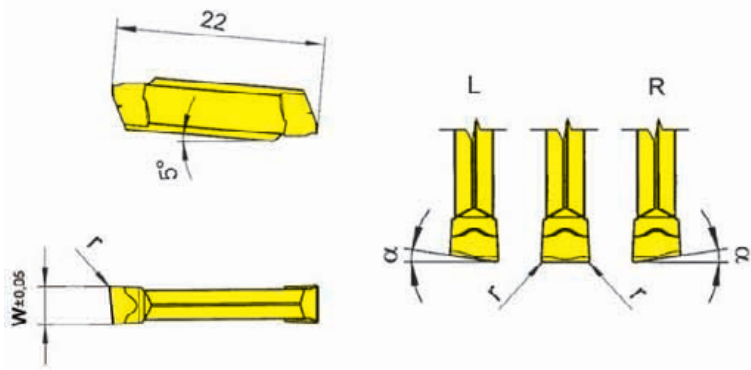

für Klemhalter
for Toolholder

Typ H224
Type

R = rechts wie gezeichnet
R = right hand version shown

L = links spiegelbildlich
L = left hand version

Bestellnummer Part number	w	r	α	Größe Size	AL96	TA43	TF42	TF43	TF45	TF46	Ti22	Ti25	TN32
S224.0200.F2	2,0	0,2	0°	01	Δ		Δ	▲	▲	▲	▲	▲	Δ
R/LS224.0520.F2	2,0	0,2	5°	01					▲/▲	▲/Δ			
S224.0250.F2	2,5	0,2	0°	02	Δ		Δ	Δ	▲	Δ	▲	Δ	Δ
R/LS224.0525.F2	2,5	0,2	5°	02				▲/Δ	▲/Δ				
S224.0300.F2	3,0	0,2	0°	03	Δ	Δ		▲	▲	▲	Δ	▲	Δ
R/LS224.0530.F2	3,0	0,2	5°	03				Δ/Δ	▲/▲		Δ/Δ		
▲ ab Lager / on stock Δ 4 Wochen / 4 weeks x auf Anfrage / upon request					P	•	•	•	•	•	•	•	•
● empfohlen / recommended					M	-	-	-	•	o	-	•	-
o bedingt einsetzbar / alternative recommendation					K	•	-	-	-	•	-	•	-
- nicht geeignet / not suitable					N	•	-	-	-	•	-	•	-
unbeschichtete HM-Sorten / uncoated grades					S	-	-	-	•	o	-	•	-
beschichtete HM-Sorten / coated grades					H	-	-	-	-	-	-	-	-
bestückt/Cermet / brazed/Cermet													

Abmessungen in mm
Dimensions in mm

Ausführung R oder L angeben
State R or L version

Wendeschneidplatten sind in rechten und linken Klemmaltern verwendbar.
Indexable inserts can be used in right and left hand toolholders.

HM-Sorten
Carbide grades



T

Klemmhalter
Toolholder
H264

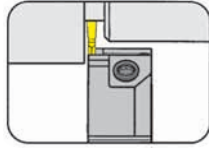

Seite/Page
T82-T85

Wendeschneidplatte
Indexable insert
264



Seite/Page
T86-T87

T

264



T

**Klemmhalter mit
Schneidplatten**

Stechbreite 1,5 - 3 mm

**Toolholder with
Inserts**

Width of groove 1,5 - 3 mm

Einstechen und Abstechen

Grooving and Parting Off



Klemmhalter

Toolholder

H264

mit Schraubklemmung
with screwed clamping

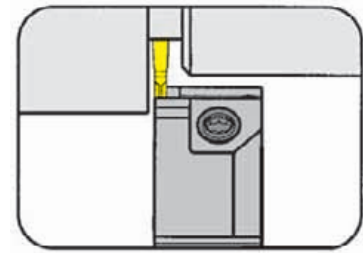

Stechtiefe bis Stechbreite	Depth of groove up to Width of groove	16 mm 1,5-2,0 mm
-------------------------------	--	---------------------

für Wendeschneidplatte
for Indexable insert

Typ 264
Type

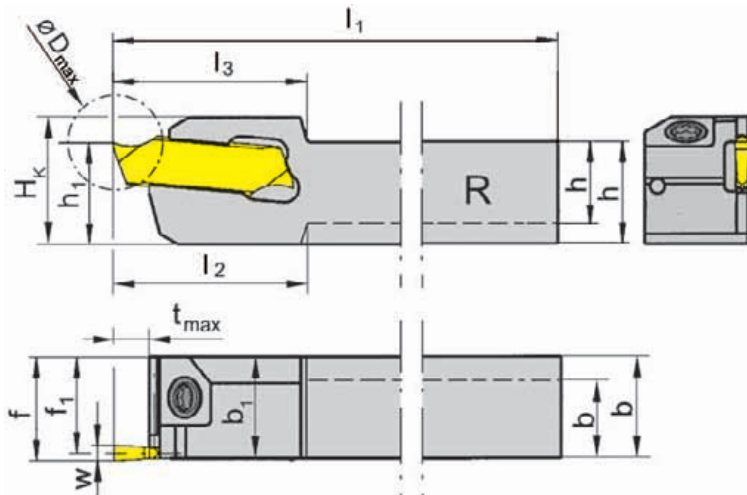

R = rechts wie gezeichnet
R = right hand version shown

L = links spiegelbildlich
L = left hand version

Bestellnummer Part number	h	b	l ₁	l ₂	l ₃	h ₁	b ₁	f ₁	f	t _{max}	D _{max}	H _K	Größe Size
R/LH264.0808.01	8	10	120	17,5	17,5	8	10	9,25	10	4	22	12,5	01
R/LH264.1010.01	10	10	120	-	17,5	10	-	9,25	10	4	22	12,5	01
R/LH264.1212.01	12	12	120	-	17,5	12	-	11,25	12	4	22	14,5	01
R/LH264.1616.01	16	16	120	-	17,5	16	-	15,25	16	4	32	18,5	01
R/LH264.1010.11	10	10	120	-	19,0	10	-	9,25	10	10	20	12,5	01
R/LH264.1212.11	12	12	120	-	19,0	12	-	11,25	12	10	20	14,5	01
R/LH264.1616.11	16	16	120	-	19,0	16	-	15,25	16	10	32	18,5	01
R/LH264.1212.21	12	12	120	-	22,0	12	-	11,25	12	13	26	15,5	01
R/LH264.1616.21	16	16	120	-	22,0	16	-	15,25	16	13	32	19,5	01
R/LH264.1010.02	10	10	120	-	17,5	10	-	9,00	10	4	32	12,5	02
R/LH264.1212.02	12	12	120	-	17,5	12	-	11,00	12	4	32	14,5	02
R/LH264.1616.02	16	16	120	-	17,5	16	-	15,00	16	4	32	18,5	02
R/LH264.1010.12	10	10	120	-	19,0	10	-	9,00	10	10	32	12,5	02
R/LH264.1212.12	12	12	120	-	19,0	12	-	11,00	12	10	32	14,5	02
R/LH264.1616.12	16	16	120	-	19,0	16	-	15,00	16	10	32	18,5	02
R/LH264.1212.22	12	12	120	-	25,0	12	-	11,00	12	16	32	14,5	02
R/LH264.1616.22	16	16	120	-	25,0	16	-	15,00	16	16	32	19,5	02

Ausführung R oder L angeben
State R or L version

w siehe WSP
w see indexable inserts

Abmessungen in mm
Dimensions in mm

Weitere Abmessungen auf Anfrage
Further sizes upon request

Das Anzugsdrehmoment der Schrauben finden Sie in den Technischen Hinweisen.
For torque specification of the screw, please see Technical Instructions.

Ersatzteile

Spare Parts

Klemmhalter Toolholder	Spannschraube Screw	TORX PLUS®-Schlüssel TORX PLUS® Wrench
R/LH264...	3.5.12T10EP	T10PL

Einstechen und Abstechen

Grooving and Parting Off



Klemmhalter

Toolholder

H264

mit Schraubklemmung
with screwed clamping

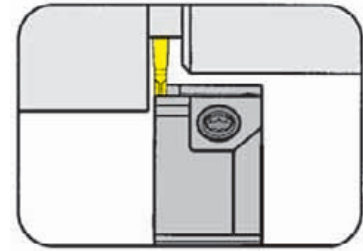

Stechtiefe bis Stechbreite	Depth of groove up to Width of groove	16 mm 2,5 mm
-------------------------------	--	-----------------

für Wendeschneidplatte
for Indexable insert

Typ 264
Type

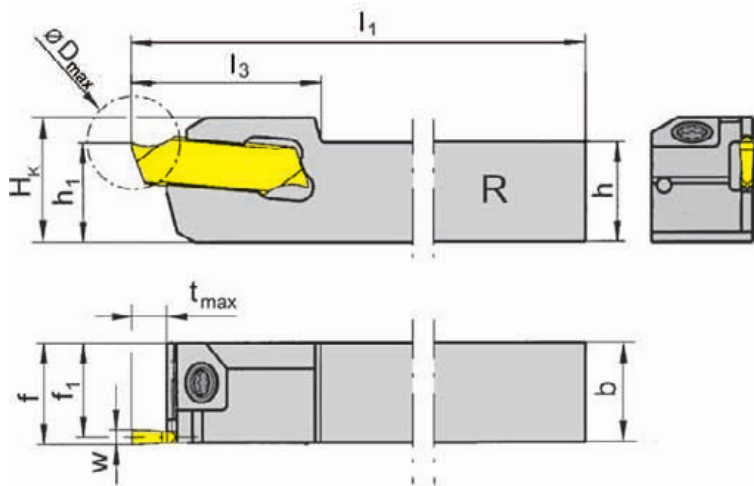

R = rechts wie gezeichnet
R = right hand version shown

L = links spiegelbildlich
L = left hand version

Bestellnummer Part number	h	b	l ₁	l ₃	h ₁	f ₁	f	t _{max}	D _{max}	H _k	Größe Size
R/LH264.1212.03	12	12	120	17,5	12	10,75	12	4	32	14,5	03
R/LH264.1616.03	16	16	120	17,5	16	14,75	16	4	32	18,5	03
R/LH264.1212.13	12	12	120	19,0	12	10,75	12	10	32	14,5	03
R/LH264.1616.13	16	16	120	19,0	16	14,75	16	10	32	18,5	03
R/LH264.1212.23	12	12	120	25,0	12	10,75	12	16	32	14,5	03
R/LH264.1616.23	16	16	120	25,0	16	14,75	16	16	32	18,5	03

Ausführung R oder L angeben
State R or L version

w siehe WSP
w see indexable inserts

Abmessungen in mm
Dimensions in mm

Weitere Abmessungen auf Anfrage
Further sizes upon request

Das Anzugsdrehmoment der Schrauben finden Sie in den Technischen Hinweisen.
For torque specification of the screw, please see Technical Instructions.

Ersatzteile

Spare Parts

Klemmhalter Toolholder	Spannschraube Screw	TORX PLUS®-Schlüssel TORX PLUS® Wrench
R/LH264...	3.5.12T10EP	T10PL



Einstechen und Abstechen

Grooving and Parting Off



Klemmhalter

Toolholder

H264

mit Schraubklemmung
with screwed clamping

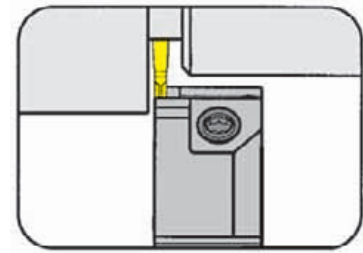

Stechtiefe bis Stechbreite	Depth of groove up to Width of groove	16 mm 3,0 mm
-------------------------------	--	-----------------

für Wendeschneidplatte
for Indexable insert

Typ 264
Type

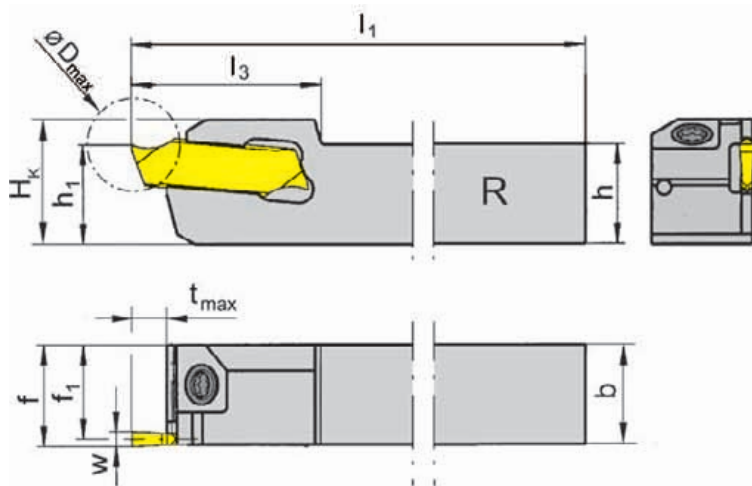

R = rechts wie gezeichnet
R = right hand version shown

L = links spiegelbildlich
L = left hand version

Bestellnummer Part number	h	b	l ₁	l ₃	h ₁	f ₁	f	t _{max}	D _{max}	H _K	Größe Size
R/LH264.1212.04	12	12	120	17,5	12	10,5	12	5	32	15	04
R/LH264.1616.04	16	16	120	17,5	16	14,5	16	5	32	19	04
R/LH264.1212.14	12	12	120	19,0	12	10,5	12	10	32	15	04
R/LH264.1616.14	16	16	120	19,0	16	14,5	16	10	32	19	04
R/LH264.1212.24	12	12	120	25,0	12	10,5	12	16	32	15	04
R/LH264.1616.24	16	16	120	25,0	16	14,5	16	16	32	19	04

Ausführung R oder L angeben
State R or L version

w siehe WSP
w see indexable inserts

Abmessungen in mm
Dimensions in mm

Weitere Abmessungen auf Anfrage
Further sizes upon request

Das Anzugsdrehmoment der Schrauben finden Sie in den Technischen Hinweisen.
For torque specification of the screw, please see Technical Instructions.

Ersatzteile

Spare Parts

Klemmhalter Toolholder	Spannschraube Screw	TORX PLUS®-Schlüssel TORX PLUS® Wrench
R/LH264...	3.5.12T10EP	T10PL

Einstechen und Abstechen

Grooving and Parting Off



Klemmhalter

Toolholder

H264

mit Selbstklemmung
with self clamping

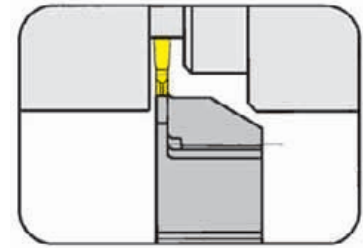

Stechtiefe bis
Stechbreite

Depth of groove up to
Width of groove

10 mm
1,5-3,0 mm

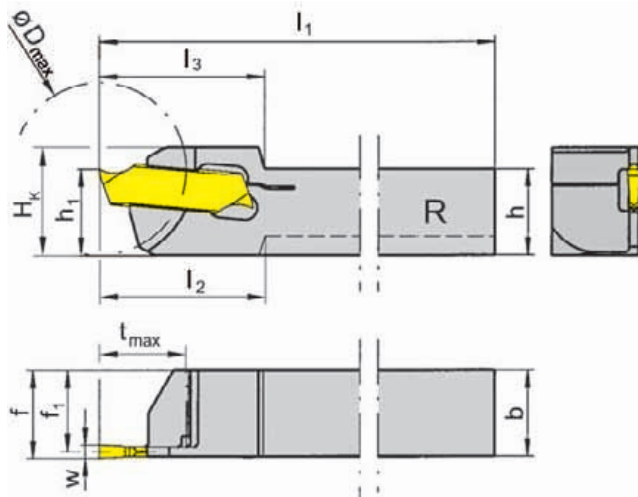

R = rechts wie gezeichnet
R = right hand version shown

L = links spiegelbildlich
L = left hand version

für Wendeschneidplatte
for Indexable insert

Typ 264
Type

Bestellnummer Part number	h	b	l ₁	l ₂	l ₃	h ₁	f ₁	f	t _{max}	D _{max}	H _k	Größe Size
R/LH264.0808.51	8	8	120	18	18	10	7,25	8	7	20	12,5	01
R/LH264.1010.61	10	10	120	-	19	10	9,25	10	10	20	12,5	01
R/LH264.1010.62	10	10	120	-	19	10	9,00	10	10	20	12,5	02
R/LH264.1212.62	12	12	120	-	19	12	11,00	12	10	20	14,5	02
R/LH264.1212.63	12	12	120	-	19	12	10,75	12	10	32	14,5	03
R/LH264.1212.64	12	12	120	-	19	12	10,50	12	10	32	14,5	04

Ausführung R oder L angeben
State R or L version

w siehe WSP
w see indexable inserts

Abmessungen in mm
Dimensions in mm

Weitere Abmessungen auf Anfrage
Further sizes upon request

Hinweis:

Der Schlüssel **P39L** gehört nicht zum Lieferumfang des Schneidträgers R/LH100...33. Bitte separat bestellen!

Note:

Wrench **P39L** is not combined with blade R/LH100...33 - separate order required!



Abstechen

Parting Off



Wendeschneidplatte

Indexable insert

264

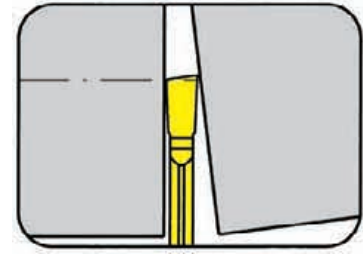

Stechtiefe bis Stechbreite	Depth of groove up to Width of groove	16 mm 1,5-3 mm
-------------------------------	--	-------------------

präzisionsgeschliffen
precision ground

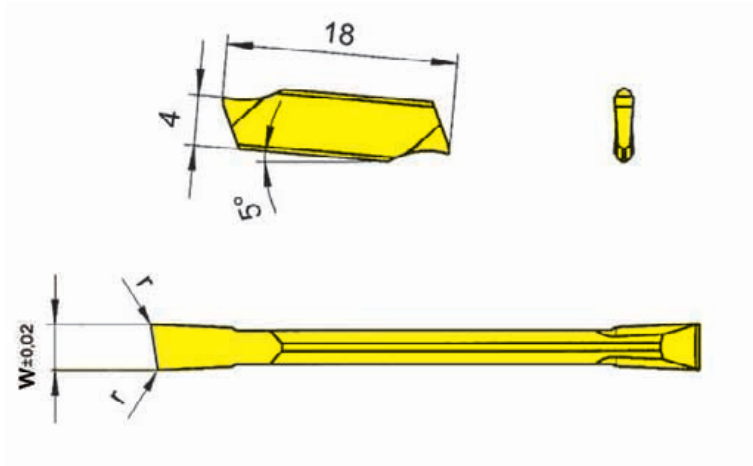

für Klemmhalter
for Toolholder

Typ H264
Type

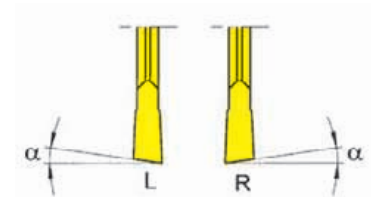

Wechselgenauigkeit
Länge ± 0,015 mm
Indexability length
± 0,015 mm

R = rechts wie gezeichnet
R = right hand version shown

L = links spiegelbildlich
L = left hand version

Bestellnummer Part number	w	r	α	Größe Size	HM-Sorten Carbide grades			
					MG12	TH35	TI25	TN35
R/L264.0815.10	1,5	0,05	8°	01	▲/▲	▲/▲	▲/▲	▲/▲
R/L264.1515.10	1,5	0,05	15°	01	▲/▲	▲/▲		▲/▲
R/L264.0820.10	2,0	0,05	8°	02	▲/▲	▲/▲		▲/▲
R/L264.1520.10	2,0	0,05	15°	02	▲/▲	▲/▲		▲/▲
R/L264.0825.10	2,5	0,10	8°	03	▲/▲	▲/▲		▲/▲
R/L264.1525.10	2,5	0,10	15°	03	▲/▲	▲/▲		▲/▲
R/L264.0830.10	3,0	0,10	8°	04	▲/▲	▲/▲		▲/▲
R/L264.1530.10	3,0	0,10	15°	04	▲/▲	▲/▲		▲/▲

▲ ab Lager / on stock Δ 4 Wochen / 4 weeks x auf Anfrage / upon request

● empfohlen / recommended

o bedingt einsetzbar / alternative recommendation

- nicht geeignet / not suitable

■ unbeschichtete HM-Sorten / uncoated grades

■ beschichtete HM-Sorten / coated grades

■ bestückt/Cermet / brazed/Cermet

Abmessungen in mm

Dimensions in mm

Ausführung R oder L angeben

State R or L version

Wendeschneidplatten sind in rechten und linken Klemmhaltern verwendbar.

Indexable inserts can be used in right and left hand toolholders.

P	○	●	●	●
M	●	●	●	●
K	●	●	●	●
N	●	●	●	●
S	●	●	●	●
H	-	-	-	-

HM-Sorten
Carbide grades

Abstechen

Parting Off



Wendeschneidplatte

Indexable insert

264

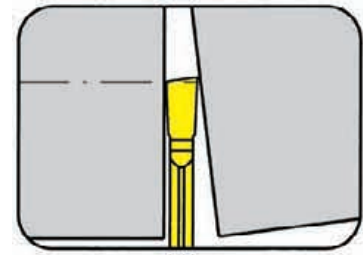

Stechtiefe bis Stechbreite	Depth of groove up to Width of groove	16 mm 1,5-3 mm
-------------------------------	--	-------------------

präzisionsgeschliffen
precision ground

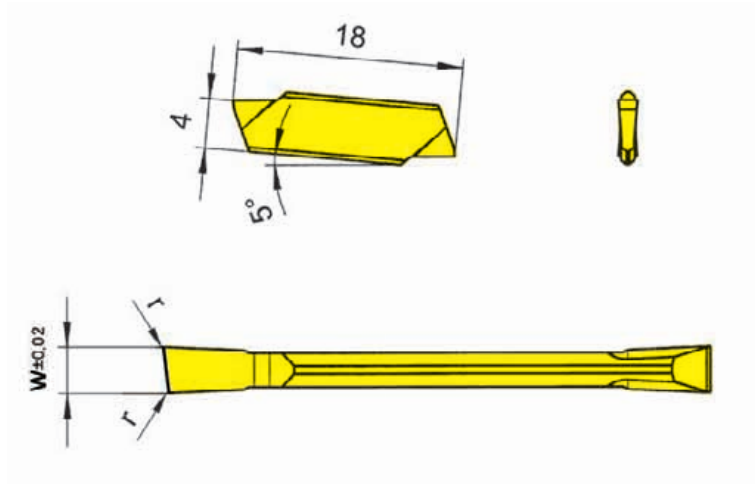

für Klemmhalter
for Toolholder

Typ H264
Type

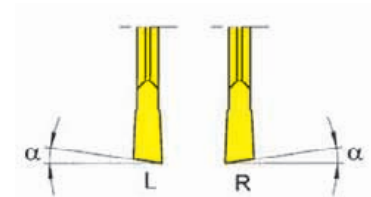

Wechselgenauigkeit
Länge ± 0,015 mm
Indexability length
± 0,015 mm

R = rechts wie gezeichnet
R = right hand version shown

L = links spiegelbildlich
L = left hand version

Bestellnummer Part number	w	r	α	Größe Size	MG12	TH35	TN35
R/L264.0815.M0	1,5	0,05	8°	01	Δ/▲	Δ/Δ	▲/Δ
R/L264.1515.M0	1,5	0,05	15°	01	▲/Δ	Δ/Δ	▲/Δ
R/L264.0820.M0	2,0	0,05	8°	02	Δ/Δ	Δ/Δ	Δ/Δ
R/L264.1520.M0	2,0	0,05	15°	02	Δ/Δ	Δ/Δ	▲/Δ
R/L264.0825.M0	2,5	0,10	8°	03	Δ/Δ	Δ/Δ	Δ/Δ
R/L264.1525.M0	2,5	0,10	15°	03	Δ/Δ	Δ/x	▲/Δ
R/L264.0830.M0	3,0	0,10	8°	04	Δ/Δ	Δ/Δ	Δ/Δ
R/L264.1530.M0	3,0	0,10	15°	04	Δ/Δ	Δ/Δ	Δ/Δ

- ▲ ab Lager / on stock Δ 4 Wochen / 4 weeks x auf Anfrage / upon request
- empfohlen / recommended
- o bedingt einsetzbar / alternative recommendation
- nicht geeignet / not suitable
- unbeschichtete HM-Sorten / uncoated grades
- beschichtete HM-Sorten / coated grades
- bestückt/Cermet / brazed/Cermet

Abmessungen in mm
Dimensions in mm

Ausführung R oder L angeben
State R or L version

Wendeschneidplatten sind in rechten und linken Klemmhaltern verwendbar.
Indexable inserts can be used in right and left hand toolholders.

P	○	●	●
M	●	●	●
K	●	●	●
N	●	●	●
S	●	●	●
H	-	-	-

HM-Sorten
Carbide grades



Klemmhalter
Toolholder
H274/H274...E

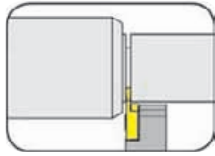

Seite/Page
T90, T97

Wendeschneidplatte
Indexable insert
S274/S274...E



Seite/Page
T91-T96, T98-T103

274



T

**Klemmhalter mit
Schneidplatten**

Schneidbreite 0,5 - 3,0 mm

**Toolholder with
Inserts**

Width of groove 0,5 - 3,0 mm

Einstechen und Drehen

Grooving and Turning



Klemmhalter

Toolholder

H274

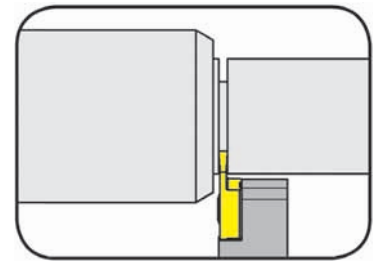

Stechtiefe	Depth of groove	6 mm
Stechbreite	Width of groove	0,5 - 3,0 mm

für Wendeschneidplatte
for Indexable insert

Typ S274
Type

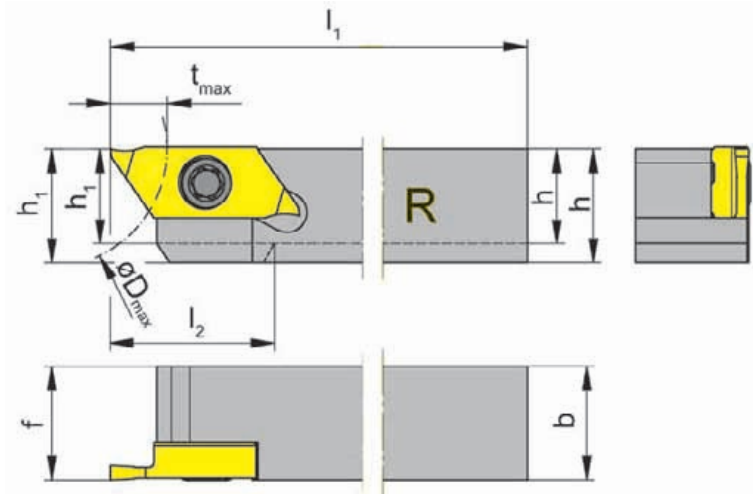

R = rechts wie gezeichnet
R = right hand version shown

L = links spiegelbildlich
L = left hand version

Bestellnummer Part number	h	b	l ₁	l ₂	h ₁	f	t _{max}	D _{max}	Größe Size
R/LH274.0808.04	8	8	100	16	8	8	6	25	04
R/LH274.1010.04	10	10	100	-	10	10	6	25	04
R/LH274.1212.04	12	12	100	-	12	12	6	25	04
R/LH274.1414.04	14	14	100	-	14	14	6	25	04
R/LH274.1616.04	16	16	125	-	16	16	6	25	04
R/LH274.2020.04	20	20	125	-	20	20	6	25	04

Ausführung R oder L angeben
State R or L version

Abmessungen in mm
Dimensions in mm

Weitere Abmessungen auf Anfrage
Further sizes upon request

Das Anzugsdrehmoment der Schrauben finden Sie in den Technischen Hinweisen.
For torque specification of the screw, please see Technical Instructions.

Ersatzteile

Spare Parts

Klemmhalter Toolholder	TORX PLUS®-Schlüssel TORX PLUS® Wrench	Schraube Screw
R/LH274.0808.04	T15PQ	
R/LH274...	T15PQ	030.3509.T15P

Abstechen

Parting Off



Wendeschneidplatte

Indexable insert

S274

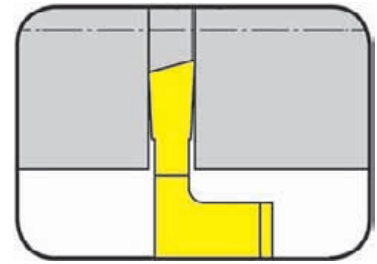

Stechtiefe bis Stechbreite	Depth of groove up to Width of groove	6 mm 0,8-2 mm
-------------------------------	--	------------------

präzisionsgeschliffen
precision ground

für Klemhalter
for Toolholder

Typ H274
Type

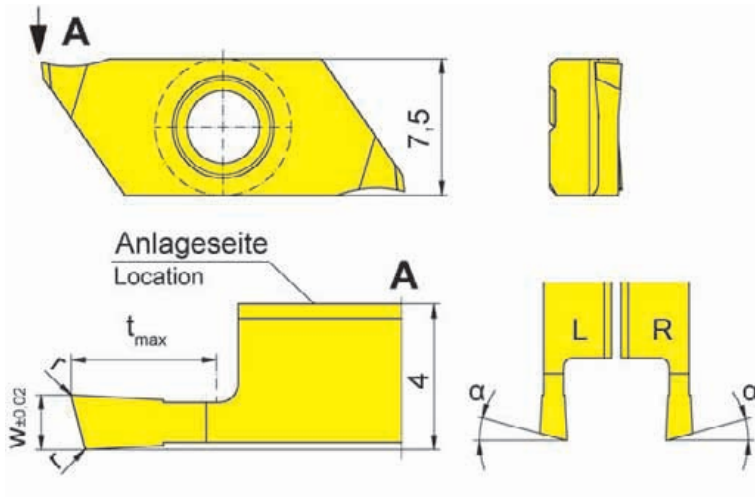

R = rechts wie gezeichnet
R = right hand version shown

L = links spiegelbildlich
L = left hand version

Wechselgenauigkeit
Länge ± 0,015 mm
Indexability length
± 0,015 mm



Bestellnummer Part number	w	r	t _{max}	α	Größe Size	TH35
R/LS274.1508.03.10	0,8	0,05	3	15°	04	▲/Δ
R/LS274.1510.03.10	1,0	0,05	3	15°	04	▲▲
R/LS274.1515.04.10	1,5	0,05	4	15°	04	▲▲
R/LS274.1520.06.10	2,0	0,05	6	15°	04	▲▲

▲ ab Lager / on stock Δ 4 Wochen / 4 weeks x auf Anfrage / upon request

● empfohlen / recommended

o bedingt einsetzbar / alternative recommendation

- nicht geeignet / not suitable

■ unbeschichtete HM-Sorten / uncoated grades

■ beschichtete HM-Sorten / coated grades

■ bestückt/Cermet / brazed/Cermet

P	•
M	•
K	•
N	•
S	•
H	-

Abmessungen in mm

Dimensions in mm

Ausführung R oder L angeben

State R or L version

Hinweis:

t_{max} 6 mm nur bei Werkstück-Ø ≤ 25 mm erreichbar.

Note:

t_{max} 6 mm can be reached only with workpiece Ø ≤ 25 mm.

HM-Sorten
Carbide grades

Abstechen

Parting Off



Wendeschneidplatte

Indexable insert

S274

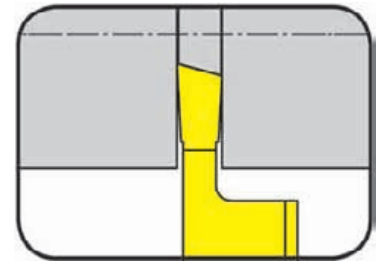

Stechtiefe bis Stechbreite	Depth of groove up to Width of groove	6 mm 0,8-2 mm
-------------------------------	--	------------------

präzisionsgeschliffen
precision ground

für Klemhalter
for Toolholder

Typ H274
Type

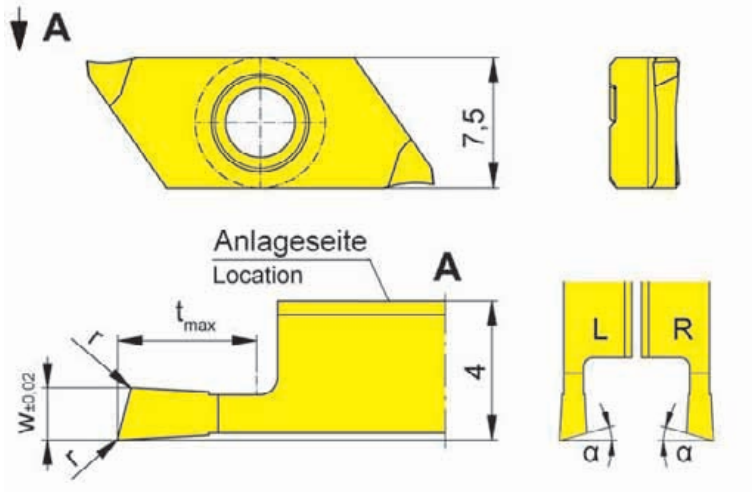

R = rechts wie gezeichnet
R = right hand version shown

L = links spiegelbildlich
L = left hand version

Wechselgenauigkeit
Länge ± 0,015 mm
Indexability length
± 0,015 mm

Bestellnummer Part number	w	r	t _{max}	α	Größe Size	TH35
LS274.1508.03.10R	0,8	0,05	3	15°	04	▲
LS274.1510.03.10R	1,0	0,05	3	15°	04	▲
LS274.1515.04.10R	1,5	0,05	4	15°	04	▲
LS274.1520.06.10R	2,0	0,05	6	15°	04	▲
RS274.1508.03.10L	0,8	0,05	3	15°	04	△
RS274.1510.03.10L	1,0	0,05	3	15°	04	△
RS274.1515.04.10L	1,5	0,05	4	15°	04	△
RS274.1520.06.10L	2,0	0,05	6	15°	04	△

- ▲ ab Lager / on stock △ 4 Wochen / 4 weeks x auf Anfrage / upon request
- empfohlen / recommended
- o bedingt einsetzbar / alternative recommendation
- nicht geeignet / not suitable
- unbeschichtete HM-Sorten / uncoated grades
- beschichtete HM-Sorten / coated grades
- bestückt/Cermet / brazed/Cermet

P	•
M	•
K	•
N	•
S	•
H	-

Abmessungen in mm
Dimensions in mm

HM-Sorten
Carbide grades

Ausführung R oder L angeben
State R or L version

Hinweis:

t_{max} 6 mm nur bei Werkstück-Ø ≤ 25 mm erreichbar.

Note:

t_{max} 6 mm can be reached only with workpiece Ø ≤ 25 mm.

T

Abstechen

Parting Off



Wendeschneidplatte

Indexable insert

S274

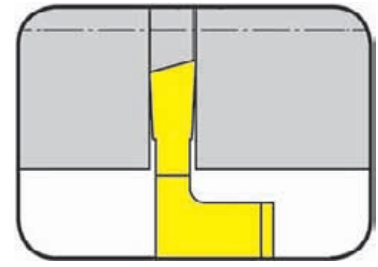

Stechtiefe bis Stechbreite	Depth of groove up to Width of groove	6 mm 1,5-2 mm
-------------------------------	--	------------------

präzisionsgeschliffen
precision ground

für Klemhalter
for Toolholder

Typ H274
Type

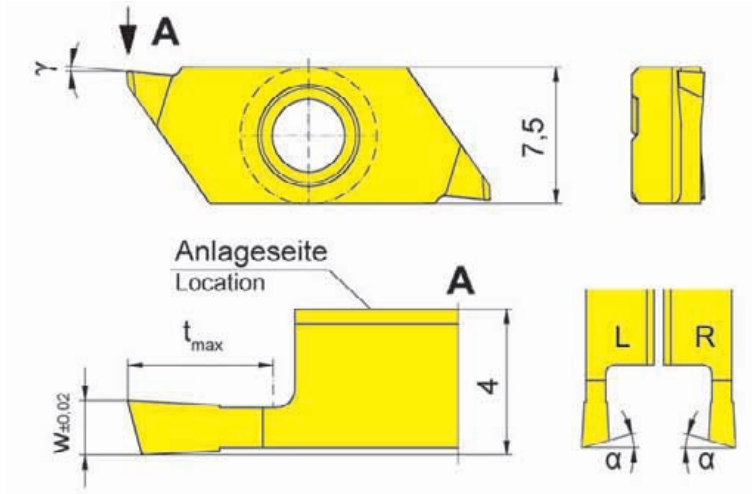

R = rechts wie gezeichnet
R = right hand version shown

L = links spiegelbildlich
L = left hand version

Wechselgenauigkeit
Länge $\pm 0,015$ mm
Indexability length
 $\pm 0,015$ mm



Bestellnummer Part number	w	t _{max}	α	γ	Größe Size	TH35
R/LS274.1515.04.20	1,5	4	15°	5°	04	▲▲
R/LS274.1520.06.20	2,0	6	15°	5°	04	▲▲

- ▲ ab Lager / on stock Δ 4 Wochen / 4 weeks x auf Anfrage / upon request
- empfohlen / recommended
- o bedingt einsetzbar / alternative recommendation
- nicht geeignet / not suitable
- unbeschichtete HM-Sorten / uncoated grades
- beschichtete HM-Sorten / coated grades
- bestückt/Cermet / brazed/Cermet

P	•
M	•
K	•
N	•
S	•
H	-

HM-Sorten
Carbide grades

Abmessungen in mm
Dimensions in mm

Ausführung R oder L angeben
State R or L version

Hinweis:

t_{max} 6 mm nur bei Werkstück-Ø ≤ 25 mm erreichbar.

Note:

t_{max} 6 mm can be reached only with workpiece Ø ≤ 25 mm.

Abstechen

Parting Off



Wendeschneidplatte

Indexable insert

S274

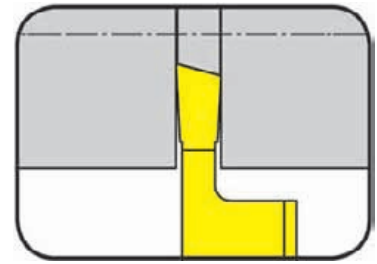

Stechtiefe bis Stechbreite	Depth of groove up to Width of groove	6 mm 1,5-2 mm
-------------------------------	--	------------------

präzisionsgeschliffen
precision ground

für Klemhalter
for Toolholder

Typ H274
Type

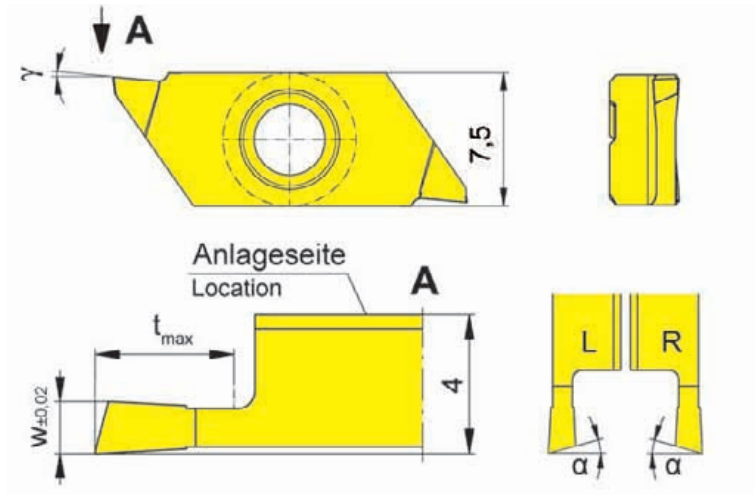

R = rechts wie gezeichnet
R = right hand version shown

L = links spiegelbildlich
L = left hand version

Wechselgenauigkeit
Länge ± 0,015 mm
Indexability length
± 0,015 mm

Bestellnummer Part number	w	t _{max}	α	γ	Größe Size	TH35
LS274.1515.04.20R	1,5	4	15°	5°	04	▲
LS274.1520.06.20R	2,0	6	15°	5°	04	▲
RS274.1515.04.20L	1,5	4	15°	5°	04	▲
RS274.1520.06.20L	2,0	6	15°	5°	04	▲

▲ ab Lager / on stock Δ 4 Wochen / 4 weeks x auf Anfrage / upon request

● empfohlen / recommended

o bedingt einsetzbar / alternative recommendation

- nicht geeignet / not suitable

■ unbeschichtete HM-Sorten / uncoated grades

■ beschichtete HM-Sorten / coated grades

■ bestückt/Cermet / brazed/Cermet

Abmessungen in mm

Dimensions in mm

Ausführung R oder L angeben

State R or L version

Hinweis:

t_{max} 6 mm nur bei Werkstück-Ø ≤ 25 mm erreichbar.

Note:

t_{max} 6 mm can be reached only with workpiece Ø ≤ 25 mm.

P	•
M	•
K	•
N	•
S	•
H	-

HM-Sorten
Carbide grades

T

Abstechen

Parting Off



Wendeschneidplatte

Indexable insert

S274

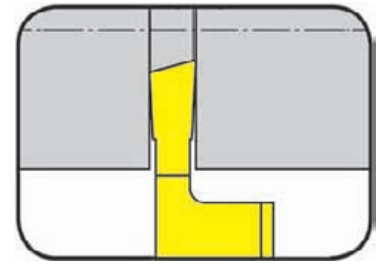

Stechtiefe bis Stechbreite	Depth of groove up to Width of groove	6 mm 0,8-2 mm
----------------------------	---------------------------------------	------------------

präzisionsgeschliffen
precision ground

für Klemhalter
for Toolholder

Typ H274
Type

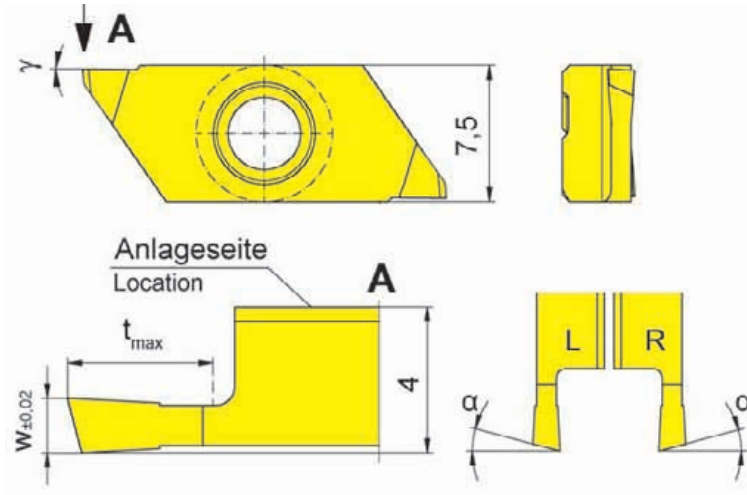

R = rechts wie gezeichnet
R = right hand version shown

L = links spiegelbildlich
L = left hand version

Wechselgenauigkeit
Länge ± 0,015 mm
Indexability length
± 0,015 mm



Bestellnummer Part number	w	t _{max}	α	γ	Größe Size	TH35
R/LS274.1508.03.M0	0,8	3	15°	0°	04	▲▲
R/LS274.1510.03.M0	1,0	3	15°	0°	04	▲▲
R/LS274.1515.04.M0	1,5	4	15°	0°	04	▲▲
R/LS274.1520.06.M0	2,0	6	15°	0°	04	▲▲

▲ ab Lager / on stock Δ 4 Wochen / 4 weeks x auf Anfrage / upon request

● empfohlen / recommended

o bedingt einsetzbar / alternative recommendation

- nicht geeignet / not suitable

■ unbeschichtete HM-Sorten / uncoated grades

■ beschichtete HM-Sorten / coated grades

■ bestückt/Cermet / brazed/Cermet

P	•
M	•
K	•
N	•
S	•
H	-

Abmessungen in mm

Dimensions in mm

Ausführung R oder L angeben

State R or L version

Hinweis:

t_{max} 6 mm nur bei Werkstück-Ø ≤ 25 mm erreichbar.

Note:

t_{max} 6 mm can be reached only with workpiece Ø ≤ 25 mm.

HM-Sorten
Carbide grades

Abstechen

Parting Off



Wendeschneidplatte

Indexable insert

S274

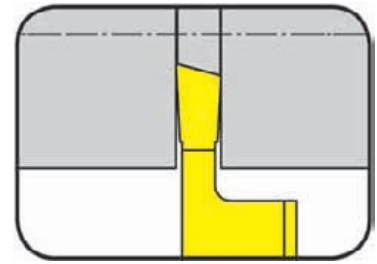

Stechtiefe bis Stechbreite	Depth of groove up to Width of groove	6 mm 0,8-2 mm
-------------------------------	--	------------------

präzisionsgeschliffen
precision ground

für Klemhalter
for Toolholder

Typ H274
Type

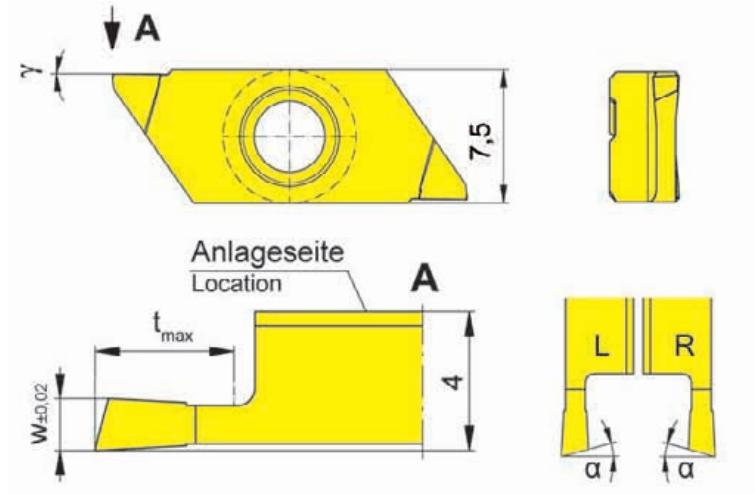

R = rechts wie gezeichnet
R = right hand version shown

L = links spiegelbildlich
L = left hand version

Wechselgenauigkeit
Länge ± 0,015 mm
Indexability length
± 0,015 mm

Bestellnummer Part number	w	t _{max}	α	γ	Größe Size	TH35
LS274.1508.03.M0R	0,8	3	15°	0°	04	▲
LS274.1510.03.M0R	1,0	3	15°	0°	04	▲
LS274.1515.04.M0R	1,5	4	15°	0°	04	▲
LS274.1520.06.M0R	2,0	6	15°	0°	04	▲
RS274.1508.03.M0L	0,8	3	15°	0°	04	▲
RS274.1510.03.M0L	1,0	3	15°	0°	04	▲
RS274.1515.04.M0L	1,5	4	15°	0°	04	▲
RS274.1520.06.M0L	2,0	6	15°	0°	04	▲

- ▲ ab Lager / on stock Δ 4 Wochen / 4 weeks x auf Anfrage / upon request
- empfohlen / recommended
- o bedingt einsetzbar / alternative recommendation
- nicht geeignet / not suitable
- unbeschichtete HM-Sorten / uncoated grades
- beschichtete HM-Sorten / coated grades
- bestückt/Cermet / brazed/Cermet

P	•
M	•
K	•
N	•
S	•
H	-

HM-Sorten
Carbide grades

Abmessungen in mm
Dimensions in mm

Ausführung R oder L angeben
State R or L version

Hinweis:

t_{max} 6 mm nur bei Werkstück-Ø ≤ 25 mm erreichbar.

Note:

t_{max} 6 mm can be reached only with workpiece Ø ≤ 25 mm.

T

Einstechen und Drehen

Grooving and Turning



Klemmhalter

Toolholder

H274...E

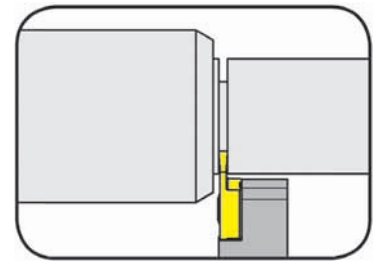

Stechtiefe	Depth of groove	6 mm
Stechbreite	Width of groove	0,5 - 3,0 mm

für Wendeschneidplatte
for Indexable insert

Typ S274...E
Type

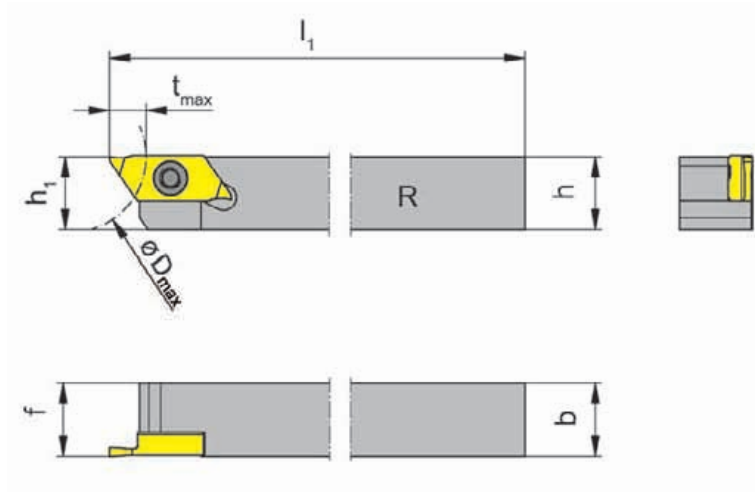

R = rechts wie gezeichnet
R = right hand version shown

L = links spiegelbildlich
L = left hand version

Bestellnummer Part number	h	b	l ₁	h ₁	f	t _{max}	D _{max}	Größe Size
R/LH274.1010.04.E	10	10	100	10	10	6	25	04
R/LH274.1212.04.E	12	12	100	12	12	6	25	04
R/LH274.1616.04.E	16	16	125	16	16	6	25	04
R/LH274.2020.04.E	20	20	125	20	20	6	25	04

Ausführung R oder L angeben
State R or L version

Abmessungen in mm
Dimensions in mm

Weitere Abmessungen auf Anfrage
Further sizes upon request

Das Anzugsdrehmoment der Schrauben finden Sie in den Technischen Hinweisen.
For torque specification of the screw, please see Technical Instructions.

Ersatzteile

Spare Parts

Klemmhalter Toolholder	Schraube Screw	TORX PLUS®-Schlüssel TORX PLUS® Wrench
R/LH274...	030.3509.T15P	T15PQ

T

Abstechen

Parting Off



Wendeschneidplatte

Indexable insert

S274...E

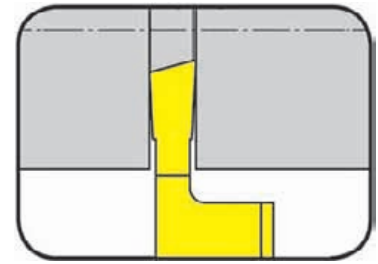

Stechtiefe bis Stechbreite	Depth of groove up to Width of groove	6 mm 0,8-2 mm
-------------------------------	--	------------------

präzisionsgeschliffen
precision ground

für Klemmhalter
for Toolholder

Typ H274...E
Type

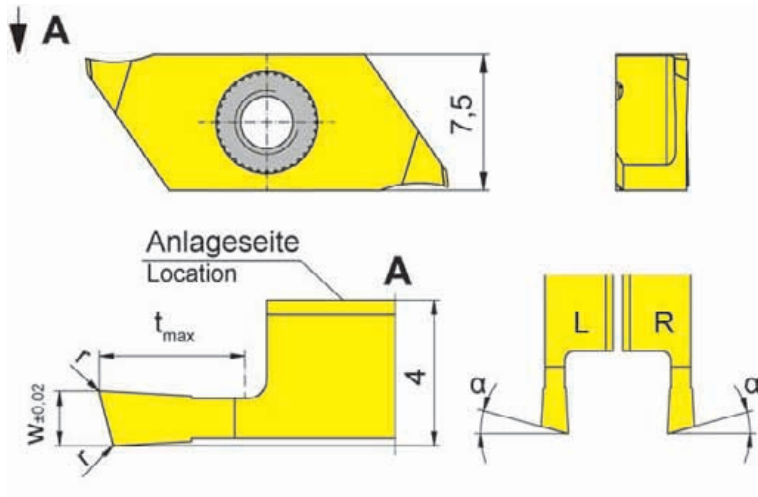

R = rechts wie gezeichnet
R = right hand version shown

L = links spiegelbildlich
L = left hand version

Wechselgenauigkeit
Länge ± 0,015 mm
Indexability length
± 0,015 mm

Bestellnummer Part number	w	r	t _{max}	α	Größe Size	TH35
R/LS274.1508.03.10.E	0,8	0,05	3	15°	04	ΔΔ
R/LS274.1510.03.10.E	1,0	0,05	3	15°	04	ΔΔ
R/LS274.1515.04.10.E	1,5	0,05	4	15°	-	ΔΔ
R/LS274.1520.06.10.E	2,0	0,05	6	15°	04	ΔΔ

▲ ab Lager / on stock Δ 4 Wochen / 4 weeks x auf Anfrage / upon request

● empfohlen / recommended

o bedingt einsetzbar / alternative recommendation

- nicht geeignet / not suitable

■ unbeschichtete HM-Sorten / uncoated grades

■ beschichtete HM-Sorten / coated grades

■ bestückt/Cermet / brazed/Cermet

Abmessungen in mm

Dimensions in mm

Ausführung R oder L angeben

State R or L version

Hinweis:

t_{max} 6 mm nur bei Werkstück-Ø ≤ 25 mm erreichbar.

Note:

t_{max} 6 mm can be reached only with workpiece Ø ≤ 25 mm.

P	•
M	•
K	•
N	•
S	•
H	-

HM-Sorten
Carbide grades

T

Abstechen

Parting Off



Wendeschneidplatte

Indexable insert

S274...E

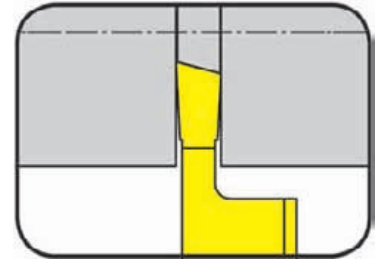

Stechtiefe bis Stechbreite	Depth of groove up to Width of groove	6 mm 0,8-2 mm
-------------------------------	--	------------------

präzisionsgeschliffen
precision ground

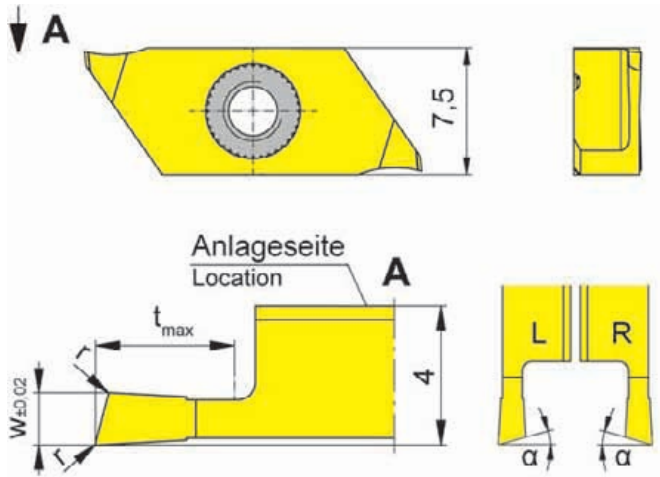

für Klemhalter
for Toolholder

Typ H274...E
Type

R = rechts wie gezeichnet
R = right hand version shown

L = links spiegelbildlich
L = left hand version

Wechselgenauigkeit
Länge ± 0,015 mm
Indexability length
± 0,015 mm



Bestellnummer Part number	w	r	t _{max}	α	Größe Size	TH35
LS274.1508.03.1R.E	0,8	0,05	3	15°	04	Δ
LS274.1510.03.1R.E	1,0	0,05	3	15°	04	Δ
LS274.1515.04.1R.E	1,5	0,05	4	15°	04	Δ
LS274.1520.06.1R.E	2,0	0,05	6	15°	04	Δ
RS274.1508.03.1L.E	0,8	0,05	3	15°	04	Δ
RS274.1510.03.1L.E	1,0	0,05	3	15°	04	Δ
RS274.1515.04.1L.E	1,5	0,05	4	15°	04	Δ
RS274.1520.06.1L.E	2,0	0,05	6	15°	04	Δ

- ▲ ab Lager / on stock Δ 4 Wochen / 4 weeks x auf Anfrage / upon request
- empfohlen / recommended
- o bedingt einsetzbar / alternative recommendation
- nicht geeignet / not suitable
- unbeschichtete HM-Sorten / uncoated grades
- beschichtete HM-Sorten / coated grades
- bestückt/Cermet / brazed/Cermet

P	•
M	•
K	•
N	•
S	•
H	-

HM-Sorten
Carbide grades

Abmessungen in mm
Dimensions in mm
Ausführung R oder L angeben
State R or L version

Hinweis:

t_{max} 6 mm nur bei Werkstück-Ø ≤ 25 mm erreichbar.

Note:

t_{max} 6 mm can be reached only with workpiece Ø ≤ 25 mm.

Abstechen

Parting Off



Wendeschneidplatte

Indexable insert

S274...E

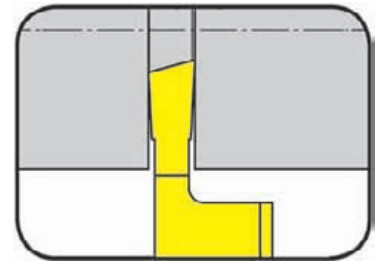

Stechtiefe bis Stechbreite	Depth of groove up to Width of groove	6 mm 1,5-2 mm
-------------------------------	--	------------------

präzisionsgeschliffen
precision ground

für Klemmhalter
for Toolholder

Typ H274...E
Type

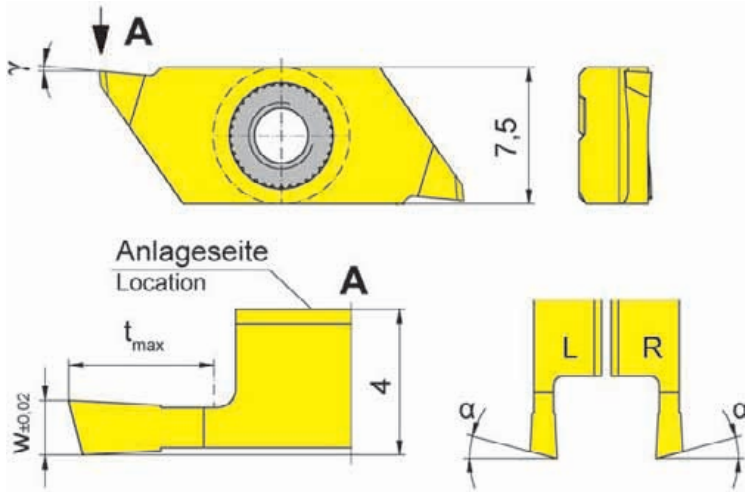

R = rechts wie gezeichnet
R = right hand version shown

L = links spiegelbildlich
L = left hand version

Wechselgenauigkeit
Länge ± 0,015 mm
Indexability length
± 0,015 mm

Bestellnummer Part number	w	t _{max}	α	γ	Größe Size	TH35
R/LS274.1515.04.20.E	1,5	4	15°	5°	04	ΔΔ
R/LS274.1520.06.20.E	2,0	6	15°	5°	04	ΔΔ

- ▲ ab Lager / on stock Δ 4 Wochen / 4 weeks x auf Anfrage / upon request
- empfohlen / recommended
- o bedingt einsetzbar / alternative recommendation
- nicht geeignet / not suitable
- unbeschichtete HM-Sorten / uncoated grades
- beschichtete HM-Sorten / coated grades
- bestückt/Cermet / brazed/Cermet

P	•
M	•
K	•
N	•
S	•
H	-

Abmessungen in mm
Dimensions in mm

HM-Sorten
Carbide grades

Ausführung R oder L angeben
State R or L version

Hinweis:

t_{max} 6 mm nur bei Werkstück-Ø ≤ 25 mm erreichbar.

Note:

t_{max} 6 mm can be reached only with workpiece Ø ≤ 25 mm.

T

Abstechen

Parting Off



Wendeschneidplatte

Indexable insert

S274...E

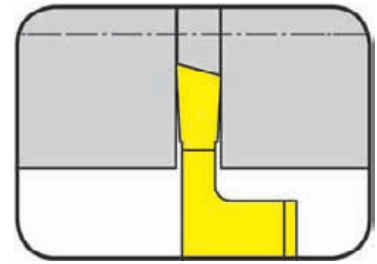

Stechtiefe bis Stechbreite	Depth of groove up to Width of groove	6 mm 1,5-2 mm
-------------------------------	--	------------------

präzisionsgeschliffen
precision ground

für Klemmhalter
for Toolholder

Typ H274...E
Type

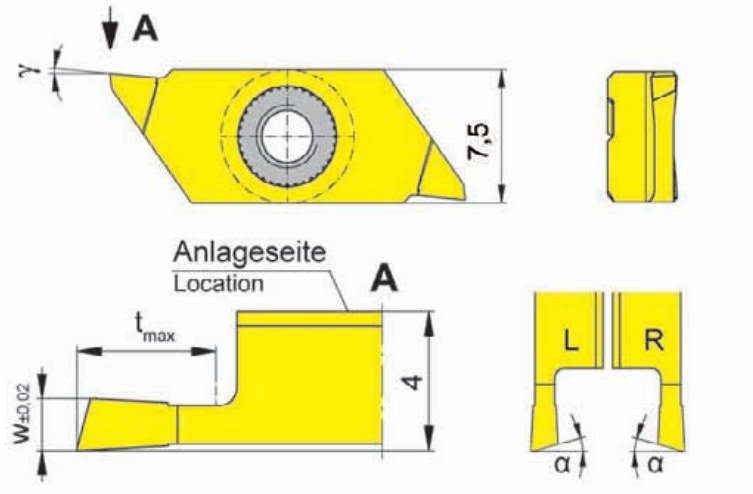

R = rechts wie gezeichnet
R = right hand version shown

L = links spiegelbildlich
L = left hand version

Wechselgenauigkeit
Länge ± 0,015 mm
Indexability length
± 0,015 mm



Bestellnummer Part number	w	t _{max}	α	γ	Größe Size	TH35
LS274.1515.04.2R.E	1,5	4	15°	5°	04	Δ
LS274.1520.06.2R.E	2,0	6	15°	5°	04	Δ
RS274.1515.04.2L.E	1,5	4	15°	5°	04	Δ
RS274.1520.06.2L.E	2,0	6	15°	5°	04	Δ

▲ ab Lager / on stock Δ 4 Wochen / 4 weeks x auf Anfrage / upon request

● empfohlen / recommended

o bedingt einsetzbar / alternative recommendation

- nicht geeignet / not suitable

■ unbeschichtete HM-Sorten / uncoated grades

■ beschichtete HM-Sorten / coated grades

■ bestückt/Cermet / brazed/Cermet

Abmessungen in mm

Dimensions in mm

Ausführung R oder L angeben

State R or L version

Hinweis:

t_{max} 6 mm nur bei Werkstück-Ø ≤ 25 mm erreichbar.

Note:

t_{max} 6 mm can be reached only with workpiece Ø ≤ 25 mm.

P	•
M	•
K	•
N	•
S	•
H	-

HM-Sorten
Carbide grades

Abstechen

Parting Off



Wendeschneidplatte

Indexable insert

S274...E

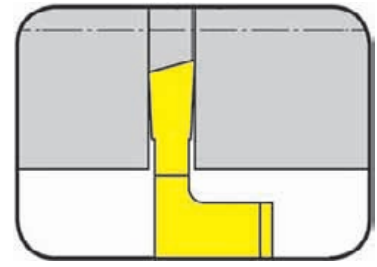

Stechtiefe bis Stechbreite	Depth of groove up to Width of groove	6 mm 0,8-2 mm
----------------------------	---------------------------------------	------------------

präzisionsgeschliffen
precision ground

für Klemhalter
for Toolholder

Typ H274...E
Type

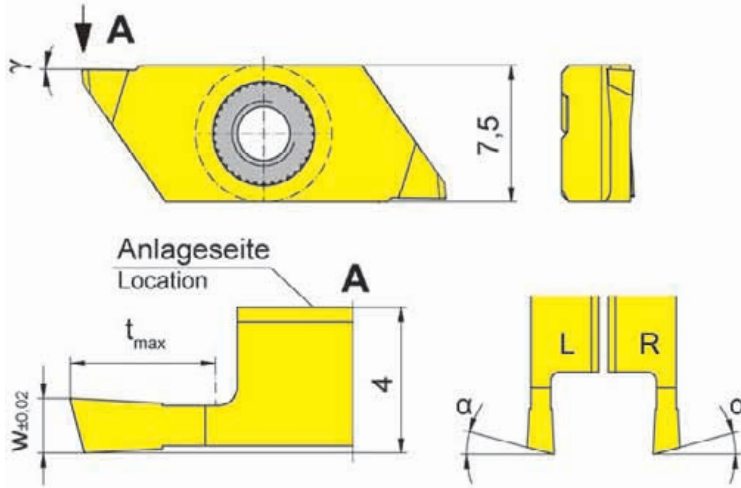

R = rechts wie gezeichnet
R = right hand version shown

L = links spiegelbildlich
L = left hand version

Wechselgenauigkeit
Länge ± 0,015 mm
Indexability length
± 0,015 mm

Bestellnummer Part number	w	t _{max}	α	γ	Größe Size	TH35
R/LS274.1508.03.M0.E	0,8	3	15°	0°	04	ΔΔ
R/LS274.1510.03.M0.E	1,0	3	15°	0°	04	ΔΔ
R/LS274.1515.04.M0.E	1,5	4	15°	0°	04	ΔΔ
R/LS274.1520.06.M0.E	2,0	6	15°	0°	04	ΔΔ

▲ ab Lager / on stock Δ 4 Wochen / 4 weeks x auf Anfrage / upon request

● empfohlen / recommended

o bedingt einsetzbar / alternative recommendation

- nicht geeignet / not suitable

■ unbeschichtete HM-Sorten / uncoated grades

■ beschichtete HM-Sorten / coated grades

■ bestückt/Cermet / brazed/Cermet

Abmessungen in mm

Dimensions in mm

Ausführung R oder L angeben

State R or L version

Hinweis:

t_{max} 6 mm nur bei Werkstück-Ø ≤ 25 mm erreichbar.

Note:

t_{max} 6 mm can be reached only with workpiece Ø ≤ 25 mm.

P	•
M	•
K	•
N	•
S	•
H	-

HM-Sorten
Carbide grades

T

Abstechen

Parting Off



Wendeschneidplatte

Indexable insert

S274...E

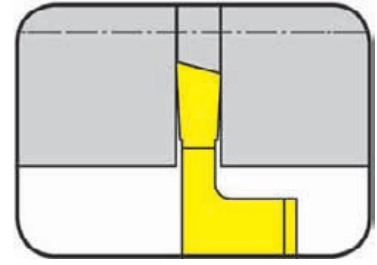

Stechtiefe bis Stechbreite	Depth of groove up to Width of groove	6 mm 0,8-2 mm
-------------------------------	--	------------------

präzisionsgeschliffen
precision ground

für Klemmhalter
for Toolholder

Typ H274...E
Type

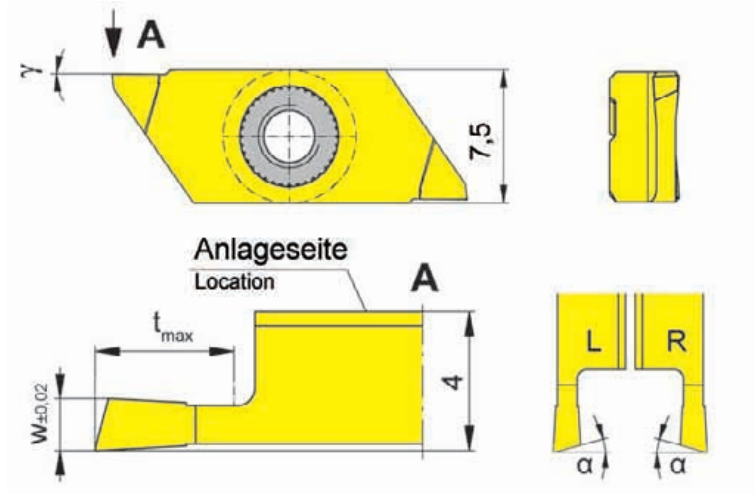

R = rechts wie gezeichnet
R = right hand version shown

L = links spiegelbildlich
L = left hand version

Wechselgenauigkeit
Länge ± 0,015 mm
Indexability length
± 0,015 mm



Bestellnummer Part number	w	t _{max}	α	γ	Größe Size	TH35
LS274.1508.03.MR.E	0,8	3	15°	0°	04	Δ
LS274.1510.03.MR.E	1,0	3	15°	0°	04	Δ
LS274.1515.04.MR.E	1,5	4	15°	0°	04	Δ
LS274.1520.06.MR.E	2,0	6	15°	0°	04	Δ
RS274.1508.03.ML.E	0,8	3	15°	0°	04	Δ
RS274.1510.03.ML.E	1,0	3	15°	0°	04	Δ
RS274.1515.04.ML.E	1,5	4	15°	0°	04	Δ
RS274.1520.06.ML.E	2,0	6	15°	0°	04	Δ

- ▲ ab Lager / on stock Δ 4 Wochen / 4 weeks x auf Anfrage / upon request
- empfohlen / recommended
- o bedingt einsetzbar / alternative recommendation
- nicht geeignet / not suitable
- unbeschichtete HM-Sorten / uncoated grades
- beschichtete HM-Sorten / coated grades
- bestückt/Cermet / brazed/Cermet

P	•
M	•
K	•
N	•
S	•
H	-

Abmessungen in mm
Dimensions in mm

HM-Sorten
Carbide grades

Ausführung R oder L angeben
State R or L version

Hinweis:

t_{max} 6 mm nur bei Werkstück-Ø ≤ 25 mm erreichbar.

Note:

t_{max} 6 mm can be reached only with workpiece Ø ≤ 25 mm.

Klemmhalter
Toolholder
218/226

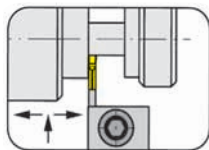

Seite/Page
T106

Grundhalter
Basic toolholder
218

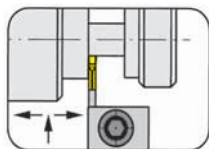

Seite/Page
T107



Seite/Page
T108-T109

Wendeschneidplatte
Indexable insert
S229/229

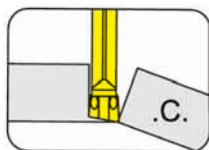

Seite/Page
T110-T111

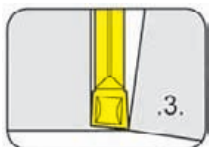

Seite/Page
T112

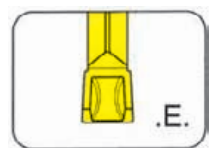

Seite/Page
T113

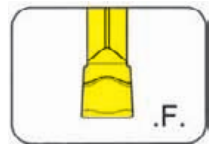

Seite/Page
T114

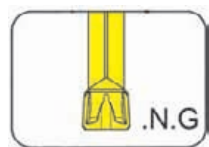

Seite/Page
T115

T

229



T

**Klemmhalter mit
Schneidplatten**

Stechbreite 3,0 - 5,0 mm

**Toolholder with
Inserts**

Width of groove 3,0 - 5,0 mm

Einstechen und Abstechen

Grooving and Parting Off



Klemmhalter

Toolholder

218

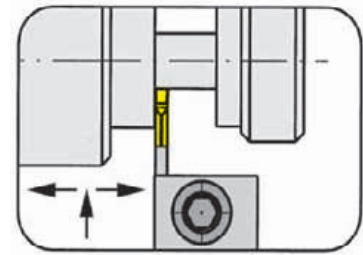

Stechtiefe bis Spannbereich	Depth of groove up to Clamping range	18 mm 3,0 - 5,0 mm
--------------------------------	---	-----------------------

für Wendeschneidplatte
for Indexable insert

Typ S229
Type

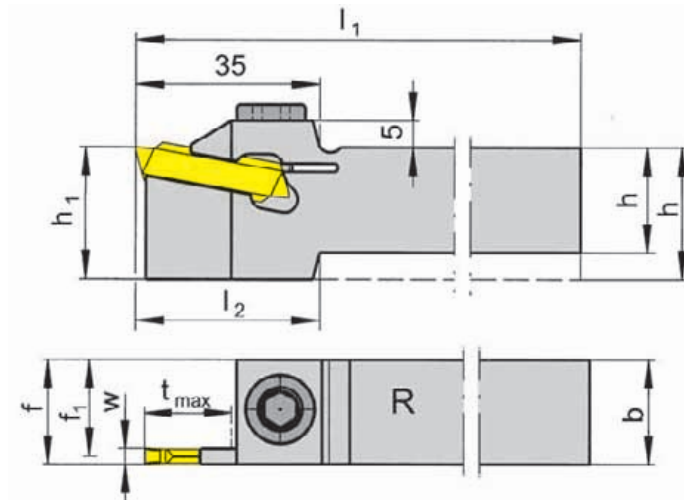

R = rechts wie gezeichnet
R = right hand version shown

L = links spiegelbildlich
L = left hand version

Bestellnummer Part number	h	b	l ₁	l ₂	h ₁	f ₁	f	t _{max}	Größe Size	Spannbereich Clamping range
R/L218.1616.03	16	16	150	45	25	14,55	f ₁ +w/2	18	03	3-4
R/L218.2020.03	20	20	150	35	25	18,55	f ₁ +w/2	18	03	3-4
R/L218.2525.03	25	25	150	-	25	23,55	f ₁ +w/2	18	03	3-4
R/L218.3225.03	32	25	170	-	32	23,55	f ₁ +w/2	18	03	3-4
R/L218.2020.04	20	20	150	35	25	17,70	f ₁ +w/2	18	04	4-5
R/L218.2525.04	25	25	150	-	25	22,70	f ₁ +w/2	18	04	4-5
R/L218.3225.04	32	25	170	-	32	22,70	f ₁ +w/2	18	04	4-5

Ausführung R oder L angeben
State R or L version

w siehe WSP
w see indexable inserts

Abmessungen in mm
Dimensions in mm

Weitere Abmessungen auf Anfrage
Further sizes upon request

Das Anzugsdrehmoment der Schrauben finden Sie in den Technischen Hinweisen.
For torque specification of the screw, please see Technical Instructions.

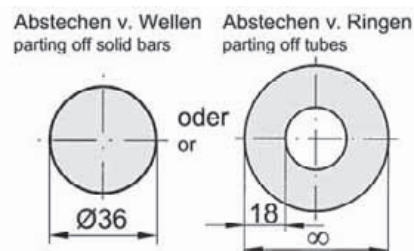

Ersatzteile

Spare Parts

Klemmhalter Toolholder	Spannschraube Screw	Inbus-Schlüssel Wrench
R/L218...	218.3	SW6,0 DIN911

Einstechen und Abstechen

Grooving and Parting Off



Grundhalter

Basic toolholder

218

mit auswechselbarer Kassette
with changeable cassette

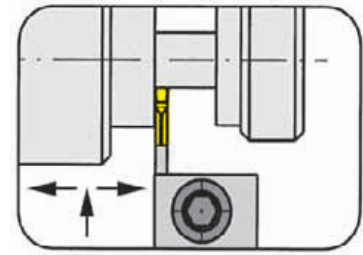

Stechtiefe bis Spannbereich	Depth of groove up to Clamping range	18 mm 3,0 - 5,0 mm
--------------------------------	---	-----------------------

für Wendeschneidplatte
for Indexable insert

Typ S229
Type

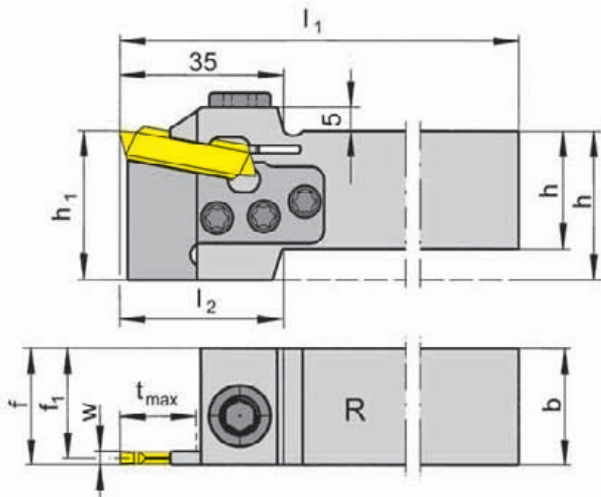

R = rechts wie gezeichnet
R = right hand version shown

L = links spiegelbildlich
L = left hand version

Bestellnummer Part number	h	b	l ₁	l ₂	h ₁	f ₁	f	t _{max}	Größe Size	Spannbereich Clamping range
R/L218.2525.K3	25	25	150	35	32	23,55	f ₁ +w/2	18	03	3-4
R/L218.3225.K3	32	25	170	-	32	23,55	f ₁ +w/2	18	03	3-4
R/L218.2525.K4	25	25	150	35	32	22,70	f ₁ +w/2	18	04	4-5
R/L218.3225.K4	32	25	170	-	32	22,70	f ₁ +w/2	18	04	4-5

Ausführung R oder L angeben
State R or L version

w siehe WSP
w see indexable inserts

Abmessungen in mm
Dimensions in mm

Weitere Abmessungen auf Anfrage
Further sizes upon request

Das Anzugsdrehmoment der Schrauben finden Sie in den Technischen Hinweisen.
For torque specification of the screw, please see Technical Instructions.

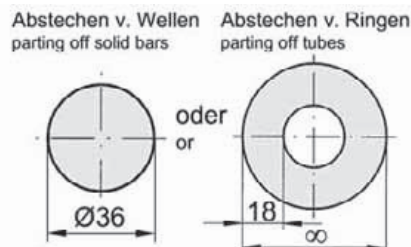

Ersatzteile

Spare Parts

Grundhalter Basic toolholder	Spannschraube Screw	Inbus-Schlüssel Wrench	Kassette Cassette	TORX PLUS®-Schlüssel TORX PLUS® Wrench
R/L210...K3	030.0518T20P	SW6,0 DIN911	NK210.32.03	T20PQ
R/L210...K4	030.0518T20P	SW6,0 DIN911	NK210.32.04	T20PQ
R/L210...K5	030.0518T20P	SW6,0 DIN911	NK210.32.05	T20PQ
R/L210...K7	030.0518T20P	SW6,0 DIN911	NK210.32.07	T20PQ

Einstechen und Abstechen

Grooving and Parting Off



Klemmhalter

Toolholder

226

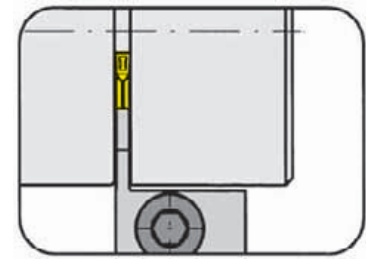

Stechtiefe bis
Spannbereich

Depth of groove up to
Clamping range

25 mm
3,0 - 5,0 mm

für Wendeschneidplatte
for Indexable insert

Typ S229
Type

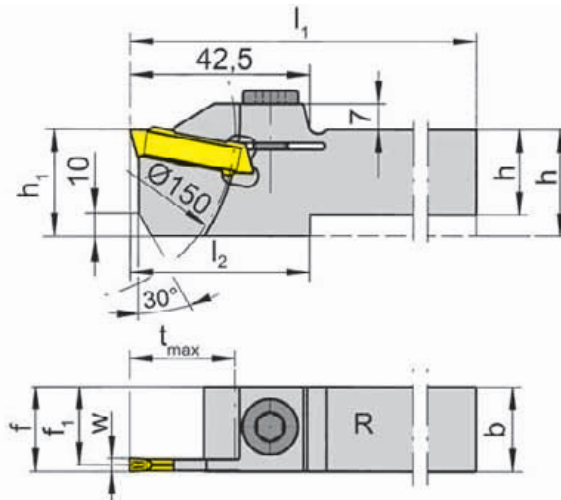

R = rechts wie gezeichnet
R = right hand version shown

L = links spiegelbildlich
L = left hand version

Bestellnummer Part number	h	b	l ₁	l ₂	h ₁	f ₁	f	t _{max}	Größe Size	Spannbereich Clamping range
R/L226.1616.03	16	16	150	52,5	32	18,55	f ₁ +w/2	25	03	3-4
R/L226.2020.03	20	20	150	42,5	32	18,55	f ₁ +w/2	25	03	3-4
R/L226.2525.03	25	25	150	-	32	23,55	f ₁ +w/2	25	03	3-4
R/L226.3225.03	32	25	170	-	32	23,55	f ₁ +w/2	25	03	3-4
R/L226.1616.04	16	16	150	52,5	32	13,70	f ₁ +w/2	25	04	4-5
R/L226.2020.04	20	20	150	42,5	32	17,70	f ₁ +w/2	25	04	4-5
R/L226.2525.04	25	25	150	-	32	22,70	f ₁ +w/2	25	04	4-5
R/L226.3225.04	32	25	170	-	32	22,70	f ₁ +w/2	25	04	4-5

Ausführung R oder L angeben
State R or L version

w siehe WSP
w see indexable inserts

Abmessungen in mm
Dimensions in mm

Weitere Abmessungen auf Anfrage
Further sizes upon request

Das Anzugsdrehmoment der Schrauben finden Sie in den Technischen Hinweisen.
For torque specification of the screw, please see Technical Instructions.

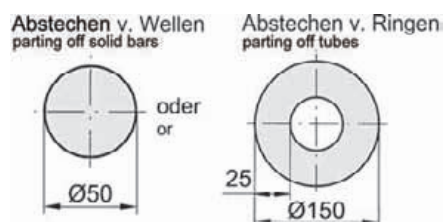

Ersatzteile

Spare Parts

Klemmhalter Toolholder	Spannschraube Screw	Inbus-Schlüssel Wrench
R/L226...	218.3	SW6,0 DIN911

Einstechen und Abstechen

Grooving and Parting Off



Klemmhalter

Toolholder

226

verstärkte Ausführung
reinforced version

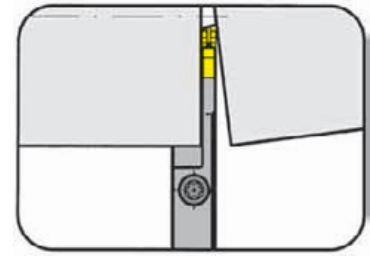

Stechtiefe bis Spannbereich	Depth of groove up to Clamping range	25 mm 3,0 - 4,0 mm
--------------------------------	---	-----------------------

für Wendeschneidplatte
for Indexable insert

Typ S229
Type

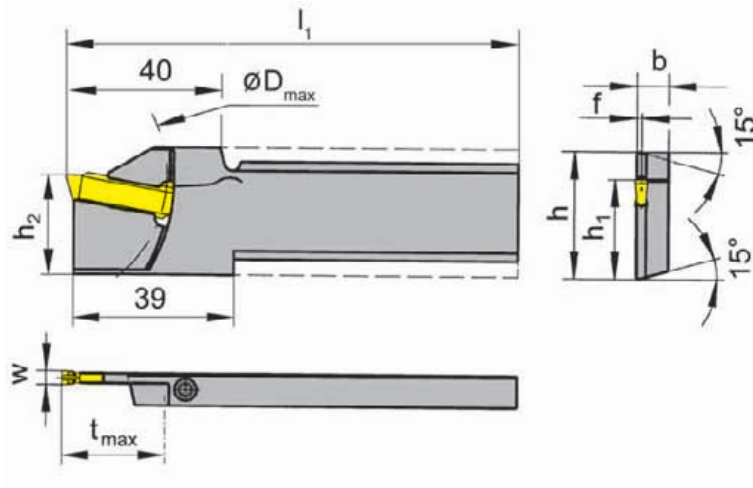

R = rechts wie gezeichnet
R = right hand version shown

L = links spiegelbildlich
L = left hand version

Bestellnummer Part number	h	b	l ₁	h ₂	f	t _{max}	D _{max}	h ₁	Größe Size	Spannbereich Clamping range
R/L226.2608.03	26	8	110	24,8	1,2	25	150	21,4	03	3
R/L226.3208.03	32	8	110	24,8	1,2	25	150	24,8	03	3
R/L226.2608.04	26	8	110	24,8	1,7	25	150	21,4	04	4
R/L226.3208.04	32	8	110	24,8	1,7	25	150	24,8	04	4

Ausführung R oder L angeben
State R or L version

w siehe WSP
w see indexable inserts

Abmessungen in mm
Dimensions in mm

Weitere Abmessungen auf Anfrage
Further sizes upon request

Das Anzugsdrehmoment der Schrauben finden Sie in den Technischen Hinweisen.
For torque specification of the screw, please see Technical Instructions.

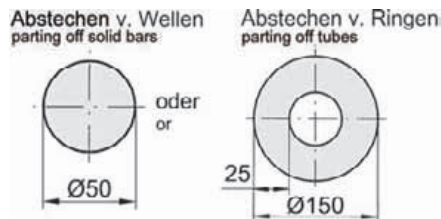

Ersatzteile

Spare Parts

Klemmhalter Toolholder	Spannschraube Screw	TORX PLUS®-Schlüssel TORX PLUS® Wrench
R/L226...	4.15T15P	T15PQ

Abstechen

Parting Off



Wendeschneidplatte

Indexable insert

S229

mit Spanformung
with chip forming

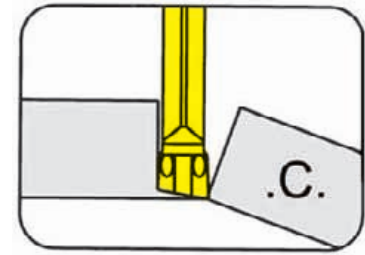

Stechtiefe bis
Stechbreite

Depth of groove up to
Width of groove

25 mm
3-4 mm

präzisionsgesintert
precision sintered

für Klemhalter
for Toolholder

Typ 218
Type 226

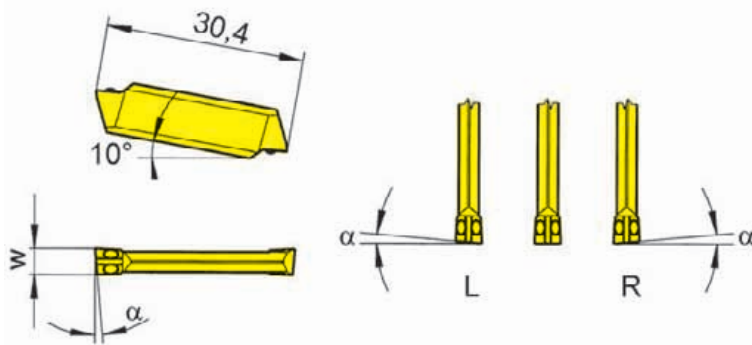

R = rechts wie gezeichnet
R = right hand version shown

L = links spiegelbildlich
L = left hand version

Wechselgenauigkeit
Länge $\pm 0,025$ mm
Indexability length $\pm 0,025$ mm

Bestellnummer Part number	w	α	Größe Size	TC92	TF45	TI25	TN35
R/LS229.0530.C0	3	5°	03	Δ/Δ	▲/▲	Δ/Δ	▲/▲
R/LS229.0540.C0	4	5°	04	Δ/Δ	Δ/Δ	Δ/Δ	▲/Δ
R/LS229.0830.C0	3	8°	03	▲/▲	▲/▲	▲/▲	▲/▲
R/LS229.0840.C0	4	8°	04	Δ/Δ	Δ/Δ	▲/Δ	▲/Δ
S229.0030.C0	3	0°	03	Δ	▲	▲	▲
S229.0040.C0	4	0°	04	Δ	Δ	▲	▲

▲ ab Lager / on stock Δ 4 Wochen / 4 weeks x auf Anfrage / upon request

● empfohlen / recommended

o bedingt einsetzbar / alternative recommendation

- nicht geeignet / not suitable

■ unbeschichtete HM-Sorten / uncoated grades

■ beschichtete HM-Sorten / coated grades

■ bestückt/Cermet / brazed/Cermet

Abmessungen in mm

Dimensions in mm

Ausführung R oder L angeben

State R or L version

Wendeschneidplatten sind in rechten und linken Klemhaltern verwendbar.

Indexable inserts can be used in right and left hand toolholders.

P	●	●	●	●
M	-	●	●	●
K	-	●	●	●
N	-	●	●	●
S	-	●	●	●
H	-	-	-	-

HM-Sorten
Carbide grades

Abstechen

Parting Off



Wendeschneidplatte

Indexable insert

S229

mit Spanformung
with chip forming

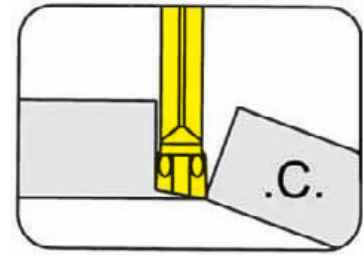

Stechtiefe bis Stechbreite	Depth of groove up to Width of groove	25 mm 3-4 mm
-------------------------------	--	-----------------

präzisionsgesintert
precision sintered

für Klemhalter
for Toolholder

Typ 218
Type 226

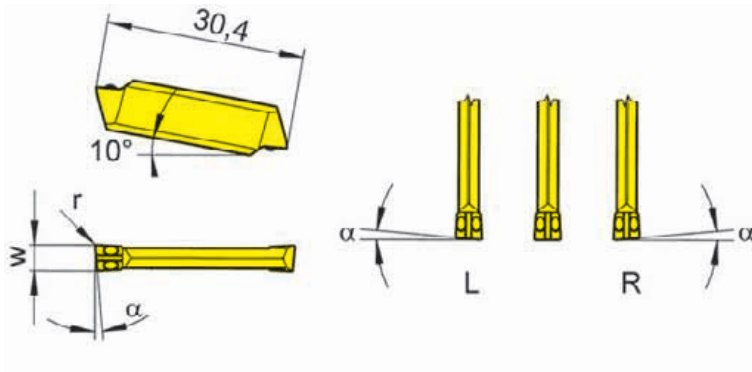

R = rechts wie gezeichnet
R = right hand version shown

L = links spiegelbildlich
L = left hand version

Wechselgenauigkeit
Länge ± 0,025 mm
Indexability length ± 0,025 mm



Bestellnummer Part number	w	r	α	Größe Size	TC92	TF45	TI25	TN35
R/LS229.0530.C1	3	0,15	5°	03	Δ/Δ	Δ/Δ	▲/Δ	▲/▲
R/LS229.0830.C1	3	0,15	8°	03	Δ/Δ	▲/▲	▲/Δ	▲/▲
S229.0030.C1	3	0,15	0°	03	Δ	▲	▲	▲
R/LS229.0540.C1	4	0,15	5°	04	Δ/Δ	Δ/Δ	Δ/Δ	Δ/Δ
R/LS229.0540.C1	4	0,15	5°	04	Δ/Δ	Δ/Δ	Δ/Δ	Δ/Δ
R/LS229.0840.C1	4	0,15	8°	04	Δ/Δ	Δ/Δ	Δ/Δ	▲/Δ
S229.0040.C1	4	0,15	0°	04	Δ	Δ	Δ	Δ

- ▲ ab Lager / on stock Δ 4 Wochen / 4 weeks x auf Anfrage / upon request
- empfohlen / recommended
- o bedingt einsetzbar / alternative recommendation
- nicht geeignet / not suitable
- unbeschichtete HM-Sorten / uncoated grades
- beschichtete HM-Sorten / coated grades
- bestückt/Cermet / brazed/Cermet

P	●	●	●	●
M	-	●	●	●
K	-	●	●	●
N	-	●	●	●
S	-	●	●	●
H	-	-	-	-

HM-Sorten
Carbide grades

Abmessungen in mm
Dimensions in mm

Ausführung R oder L angeben
State R or L version

Wendeschneidplatten sind in rechten und linken Klemhaltern verwendbar.
Indexable inserts can be used in right and left hand toolholders.

Abstechen

Parting Off



Wendeschneidplatte

Indexable insert

229/S229

mit Spanformrille
with chip former

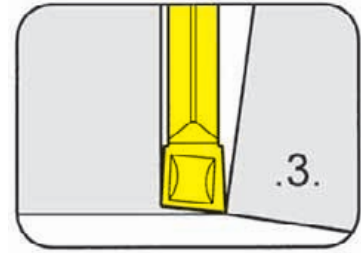

Stechtiefe bis Stechbreite	Depth of groove up to Width of groove	25 mm 3-4 mm
-------------------------------	--	-----------------

präzisionsgesintert
precision sintered

für Klemmhalter
for Toolholder

Typ 218
Type 226

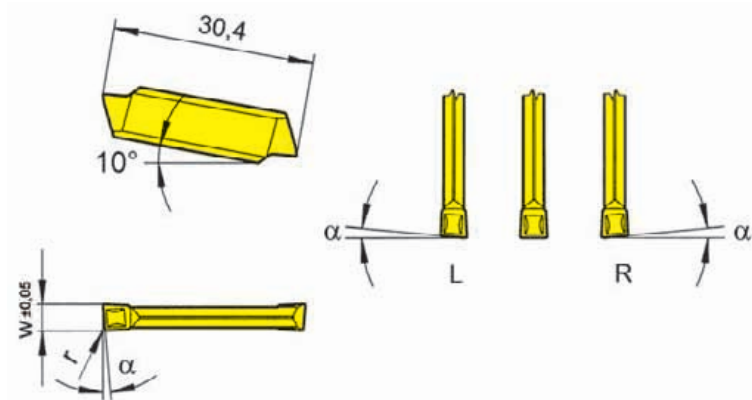

R = rechts wie gezeichnet
R = right hand version shown

L = links spiegelbildlich
L = left hand version

Wechselgenauigkeit
Länge ± 0,04 mm
Indexability length ± 0,04 mm

Bestellnummer Part number	w	r	α	Größe Size	MG12	AL96	AS62	AS66	H54	P20	TA45	TC92	TF45	TI22	TI25	TN32	TN35
					▲/▲	▲	▲/▲	▲	▲	Δ/Δ	▲/▲	▲	▲	▲/▲	▲	▲/▲	▲/▲
R/L229.5300.31	3	0,2	5°	03	▲/▲		▲/▲					▲/Δ			▲/▲	▲/▲	▲/▲
R/LS229.0530.32	3	0,2	5°	03			▲/▲				Δ/Δ	Δ/Δ	▲/▲		▲/▲	▲/▲	▲/▲
S229.0300.32	3	0,2	0°	03	▲	▲	▲	▲	▲	Δ	Δ	▲	▲	Δ	▲	▲	▲
R/LS229.0540.32	4	0,2	5°	04			▲/Δ				Δ/Δ	Δ/Δ	▲/▲		▲/▲	Δ/▲	Δ/Δ
S229.0400.32	4	0,2	0°	04	Δ	▲	▲	▲	▲	Δ	Δ	▲	▲	Δ	▲	▲	▲
					P	○	●	●	●	●	●	●	●	●	●	●	●
					M	●	-	-	○	●	-	●	-	●	-	●	-
					K	●	●	-	●	-	●	-	●	-	●	-	●
					N	●	●	-	●	-	●	-	●	-	●	-	●
					S	●	-	-	○	-	●	-	●	-	●	-	●
					H	-	-	-	-	-	-	-	-	-	-	-	-

▲ ab Lager / on stock Δ 4 Wochen / 4 weeks x auf Anfrage / upon request
 ● empfohlen / recommended
 ○ bedingt einsetzbar / alternative recommendation
 - nicht geeignet / not suitable
 unbeschichtete HM-Sorten / uncoated grades
 beschichtete HM-Sorten / coated grades
 bestückt/Cermet / brazed/Cermet

Abmessungen in mm
Dimensions in mm

Ausführung R oder L angeben
State R or L version

Hinweis:

R/L229.5300.31 **präzisionsgeschliffen**, Längenmaß 30,0 mm

Note:

R/L229.5300.31 **precision ground**, length 30,0 mm

Wendeschneidplatten sind in rechten und linken Klemmhaltern verwendbar.
Indexable inserts can be used in right and left hand toolholders.

HM-Sorten
Carbide grades

Einstechen und Abstechen

Grooving and Parting Off



Wendeschneidplatte

Indexable insert

S229

mit Spanformung
with chip forming

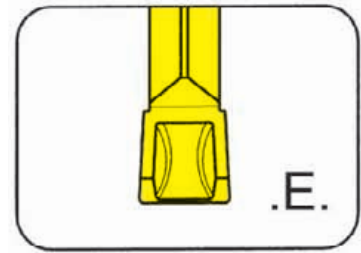

Stechtiefe bis Stechbreite	Depth of groove up to Width of groove	25 mm 3-4 mm
-------------------------------	--	-----------------

präzisionsgesintert
precision sintered

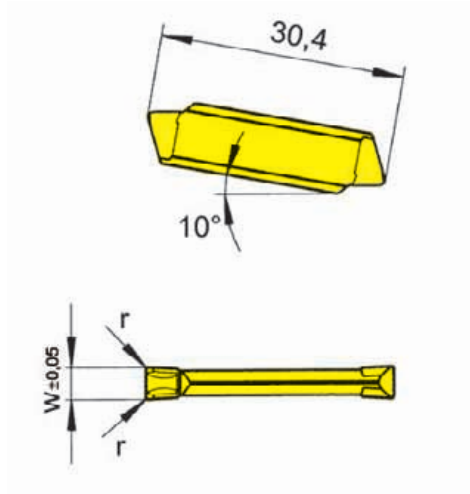

für Klemmhalter
for Toolholder

Typ 218
Type 226

Wechselgenauigkeit
Länge ± 0,06 mm
Indexability length ± 0,06 mm



Bestellnummer Part number	w	r	Größe Size	AS62	TC92	TF45	TF46	TI25
S229.0300.E2	3	0,2	03	▲	▲	▲	▲	▲
S229.0300.E4	3	0,4	03	▲	▲	▲		
S229.0400.E2	4	0,2	04	▲	▲	▲	▲	▲
S229.0400.E4	4	0,4	04	▲	▲	▲		
P	●	●	●	●	●	●	●	●
M	-	-	●	○	●			
K	-	-	●	●	●			
N	-	-	●	●	●			
S	-	-	●	○	●			
H	-	-	-	-	-			

- ▲ ab Lager / on stock Δ 4 Wochen / 4 weeks x auf Anfrage / upon request
- empfohlen / recommended
- bedingt einsetzbar / alternative recommendation
- nicht geeignet / not suitable
- unbeschichtete HM-Sorten / uncoated grades
- beschichtete HM-Sorten / coated grades
- bestückt/Cermet / brazed/Cermet

Abmessungen in mm
Dimensions in mm

Wendeschneidplatten sind in rechten und linken Klemmhaltern verwendbar.
Indexable inserts can be used in right and left hand toolholders.

HM-Sorten
Carbide grades

Einstechen und Abstechen

Grooving and Parting Off



Wendeschneidplatte

Indexable insert

S229

mit Spanformung
with chip forming

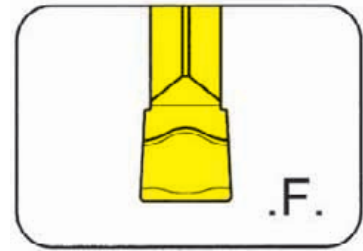

Stechtiefe bis Stechbreite	Depth of groove up to Width of groove	25 mm 3-4 mm
-------------------------------	--	-----------------

präzisionsgesintert
precision sintered

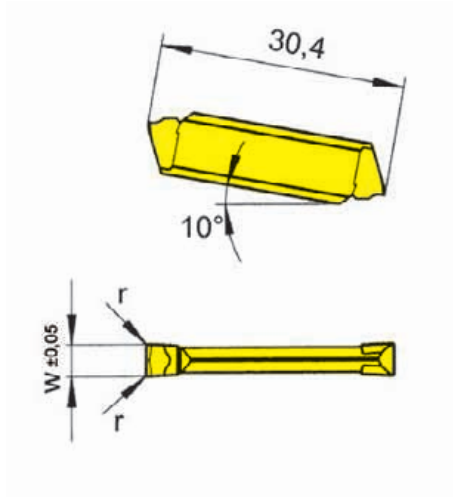

für Klemmhalter
for Toolholder

Typ 218
Type 226

Wechselgenauigkeit
Länge ± 0,06 mm
Indexability length ± 0,06 mm

T

Bestellnummer Part number	w	r	Größe Size	TC92	TF43	TF45	TF46	TI22	TI25
S229.0300.F2	3	0,2	03	Δ	▲	▲	▲	▲	Δ
S229.0300.F4	3	0,4	03	Δ		▲	Δ		Δ
S229.0400.F2	4	0,2	04	Δ	Δ	▲	Δ		Δ
S229.0400.F4	4	0,4	04	Δ		▲	Δ		Δ
▲ ab Lager / on stock Δ 4 Wochen / 4 weeks x auf Anfrage / upon request				P	●	●	●	●	●
● empfohlen / recommended				M	-	-	○	-	●
○ bedingt einsetzbar / alternative recommendation				K	-	-	●	-	●
- nicht geeignet / not suitable				N	-	-	●	-	●
■ unbeschichtete HM-Sorten / uncoated grades				S	-	-	○	-	●
■ beschichtete HM-Sorten / coated grades				H	-	-	-	-	-
■ bestückt/Cermet / brazed/Cermet									

Abmessungen in mm
Dimensions in mm

Wendeschneidplatten sind in rechten und linken Klemmhaltern verwendbar.
Indexable inserts can be used in right and left hand toolholders.

HM-Sorten
Carbide grades

Einstechen und Abstechen

Grooving and Parting Off



Wendeschneidplatte

Indexable insert

S229

mit Spanformung
with chip forming

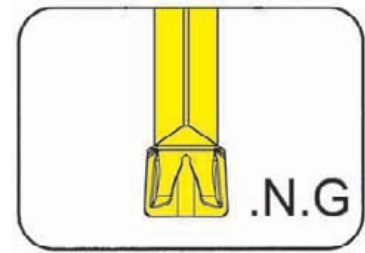

Stechtiefe bis Stechbreite	Depth of groove up to Width of groove	25 mm 3-5 mm
-------------------------------	--	-----------------

präzisionsgesintert
precision sintered

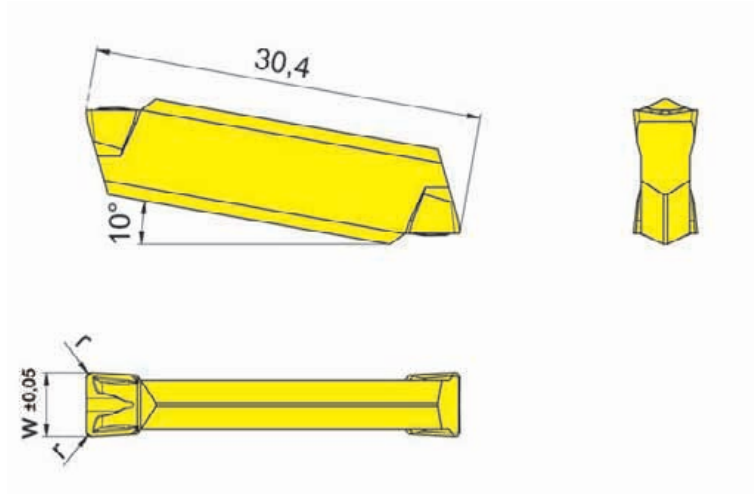

für Klemmhalter
for Toolholder

Typ 218
Type 226

Wechselgenauigkeit
Länge ± 0,06 mm
Indexability length ± 0,06 mm



Bestellnummer Part number	w	r	Größe Size	AS45	AS62	DD25	T125	
S229.0300.N2.G	3	0,2	03	▲				
S229.0300.N4.G	3	0,4	03	▲				
S229.0400.N2.G	4	0,2	04	▲				
S229.0400.N4.G	4	0,4	04	▲				
S229.0500.N2.G	5	0,2	04			△	△	
S229.0500.N4.G	5	0,4	04	▲	▲	△	△	
S229.0500.N6.G	5	0,6	04	▲	△		△	
S229.0500.N8.G	5	0,8	04		▲			
▲ ab Lager / on stock △ 4 Wochen / 4 weeks x auf Anfrage / upon request				P	•	•	-	•
● empfohlen / recommended				M	•	-	-	•
o bedingt einsetzbar / alternative recommendation				K	•	-	-	•
- nicht geeignet / not suitable				N	o	-	•	•
■ unbeschichtete HM-Sorten / uncoated grades				S	•	-	o	•
■ beschichtete HM-Sorten / coated grades				H	-	-	-	-
■ bestückt/Cermet / brazed/Cermet								

Abmessungen in mm
Dimensions in mm

Wendeschneidplatten sind in rechten und linken Klemmhaltern verwendbar.
Indexable inserts can be used in right and left hand toolholders.

HM-Sorten
Carbide grades

Klemmhalter
Toolholder
360/368/391

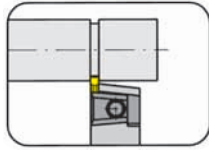

Seite/Page
T118

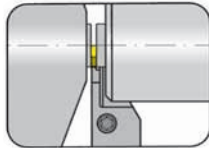

Seite/Page
T119-T120

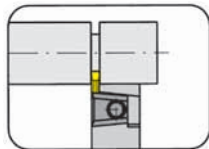

Seite/Page
T121

Wendescheidplatte
Indexable insert
312/S312

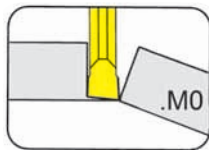

Seite/Page
T122

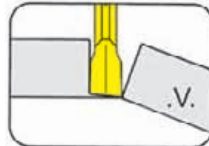

Seite/Page
T123

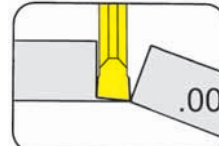

Seite/Page
T124-T126

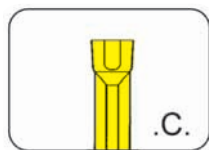

Seite/Page
T127

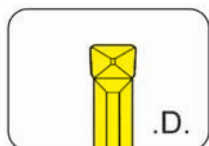

Seite/Page
T128

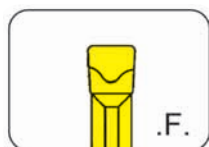

Seite/Page
T129

T

312



T

**Klemmhalter mit
Schneidplatten**

Stechbreite 0,5 - 3,0 mm

**Toolholder with
Inserts**

Width of groove 0,5 - 3,0 mm

Einstechen und Abstechen

Grooving and Parting Off



Klemmhalter

Toolholder

360

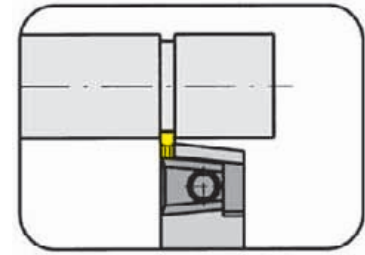

Stechtiefe bis Spannbereich	Depth of groove up to Clamping range	6 mm 1,9 - 2,9 mm
--------------------------------	---	----------------------

für Wendeschneidplatte
for Indexable insert

Typ 312
Type S312

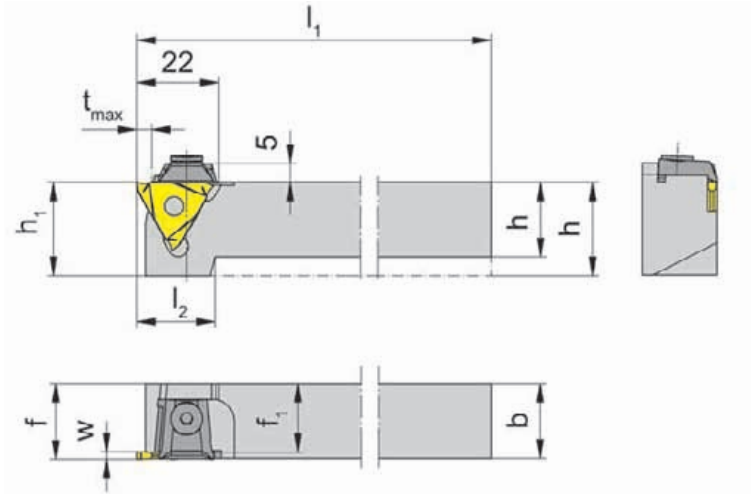

R = rechts wie gezeichnet
R = right hand version shown

L = links spiegelbildlich
L = left hand version

Bestellnummer Part number	h	b	l ₁	l ₂	h ₁	f ₁	f	t _{max}	Größe Size	Spannbereich Clamping range
R/L360.1212.02	12	12	100	24	25	9,5	f ₁ +w-a ₁	6	02	1,9-2,9
R/L360.1616.02	16	16	125	22	25	13,5	f ₁ +w-a ₁	6	02	1,9-2,9
R/L360.2020.02	20	20	125	21	25	17,5	f ₁ +w-a ₁	6	02	1,9-2,9
R/L360.2525.02	25	25	150	-	25	22,5	f ₁ +w-a ₁	6	02	1,9-2,9
R/L360.3232.02	32	32	170	-	32	29,5	f ₁ +w-a ₁	6	02	1,9-2,9

Ausführung R oder L angeben
State R or L version

w, a₁ siehe WSP
w, a₁ see indexable inserts

Abmessungen in mm
Dimensions in mm

Weitere Abmessungen auf Anfrage
Further sizes upon request

t_{max} nur bei Werkstück-Ø ≤ 40 mm erreichbar.
t_{max} can be reached only with workpiece Ø ≤ 40 mm

Das Anzugsdrehmoment der Schrauben finden Sie in den Technischen Hinweisen.
For torque specification of the screw, please see Technical Instructions.

Ersatzteile

Spare Parts

Klemmhalter Toolholder	Inbus-Schlüssel Wrench	Spannelement Clamping element
R/L360.1...	SW3,0 DIN911	11.3
R/L360...	SW3,0 DIN911	16.4

Abstechen

Parting Off



Klemmhalter

Toolholder

368

Stechtiefe bis Stechbreite	Depth of groove up to Width of groove	8 mm 0,5 - 1,5 mm
-------------------------------	--	----------------------

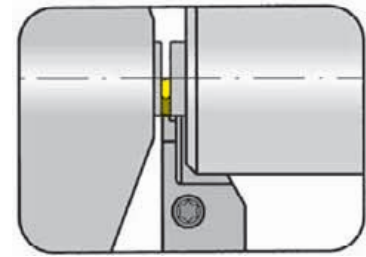

für TRAUB-Maschinen (TNL12/7)
for machines TRAUB (TNL12/7)

für Wendeschneidplatte
for Indexable insert

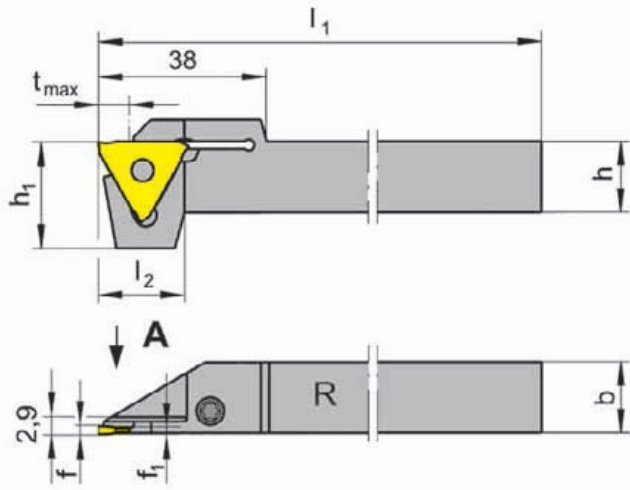

Typ 312 „G“
Type

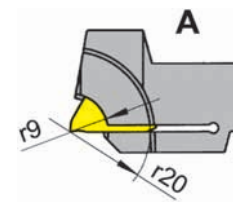

R = rechts wie gezeichnet
R = right hand version shown

L = links spiegelbildlich
L = left hand version

nur für umfangs-
geschliffene Form-WSP
only for periferal grounded
profiled inserts



Bestellnummer Part number	h	b	l ₁	l ₂	h ₁	f ₁	f	t _{max}
R/L368.1212.08	12	12	95	19,5	24	1,0	f ₁ +a ₁	8
R/L368.1616.08	16	16	95	19,5	24	1,0	f ₁ +a ₁	8
R/L368.1212.11	12	12	95	19,5	24	1,3	f ₁ +a ₁	8
R/L368.1616.11	16	16	95	19,5	24	1,3	f ₁ +a ₁	8

Ausführung R oder L angeben
State R or L version

a₁ siehe WSP
a₁ see indexable inserts

Abmessungen in mm
Dimensions in mm

Halter R/L368...08 für WSP:

R/L312.0805... / R/L312.0808... / R/L312.0510... R/L312.0512... / R/L312.1210... / R/L312.0012...

Toolholder R/L368...08 for indexable inserts:

R/L312.0805... / R/L312.0808... / R/L312.0510... R/L312.0512... / R/L312.1210... / R/L312.0012...

Halter R/L368...11 für WSP:

R/L312.0515... / R/L312.0015...

Toolholder R/L368...11 for indexable inserts:

R/L312.0515... / R/L312.0015...

Das Anzugsdrehmoment der Schrauben finden Sie in den Technischen Hinweisen.
For torque specification of the screw, please see Technical Instructions.

Ersatzteile

Spare Parts

Klemmhalter Toolholder	Spannschraube Screw	TORX PLUS®-Schlüssel TORX PLUS® Wrench
R/L368...	4.15T15P	T15PQ

Abstechen

Parting Off



Klemmhalter

Toolholder

368

verstärkte Ausführung
reinforced version

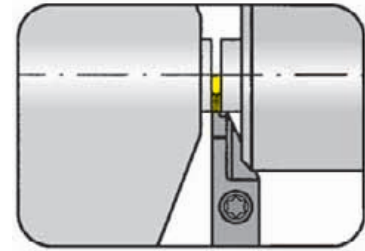

Stechtiefe bis	Depth of groove up to	8 mm
Stechbreite	Width of groove	0,5 - 1,5 mm

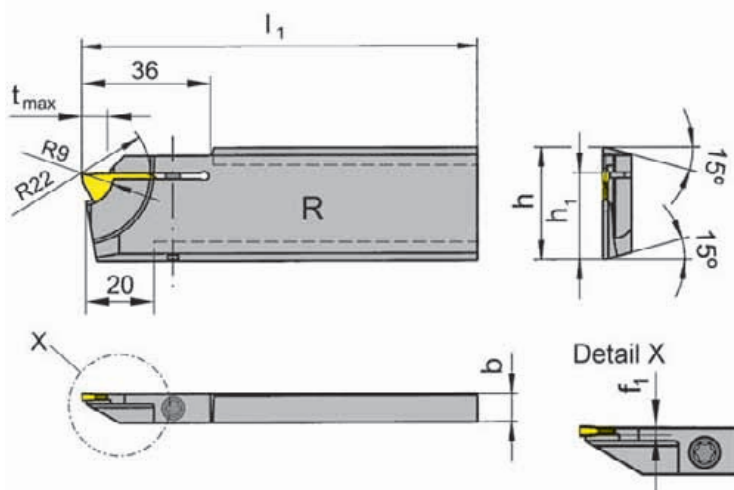

R = rechts wie gezeichnet
R = right hand version shown

L = links spiegelbildlich
L = left hand version

für Wendeschneidplatte
for Indexable insert

Typ 312 „G“
Type

nur für umfangs-
geschliffene Form-WSP
only for periferal grounded
profiled inserts

Bestellnummer Part number	h	b	l ₁	h ₁	f ₁	t _{max}
R/L368.2608.08	26	8	110	21,4	1,0	8
R/L368.3208.08	32	8	110	24,8	1,0	8
R/L368.2608.11	26	8	110	21,4	1,3	8
R/L368.3208.11	32	8	110	24,8	1,3	8

Ausführung R oder L angeben
State R or L version

Abmessungen in mm
Dimensions in mm

Halter R/L368...08 für WSP:

R/L312.0805... / R/L312.0808... / R/L312.0510... R/L312.0512... / R/L312.1210... / R/L312.0012...

Toolholder R/L368...08 for indexable inserts:

R/L312.0805... / R/L312.0808... / R/L312.0510... R/L312.0512... / R/L312.1210... / R/L312.0012...

Halter R/L368...11 für WSP:

R/L312.0515... / R/L312.0015...

Toolholder R/L368...11 for indexable inserts:

R/L312.0515... / R/L312.0015...

Das Anzugsdrehmoment der Schrauben finden Sie in den Technischen Hinweisen.

For torque specification of the screw, please see Technical Instructions.

Ersatzteile

Spare Parts

Klemmhalter Toolholder	Spannschraube Screw	TORX PLUS®-Schlüssel TORX PLUS® Wrench
R/L368...	4.15T15P	T15PQ

Einstecken (außen)

Grooving (external)



Klemmhalter

Toolholder

391

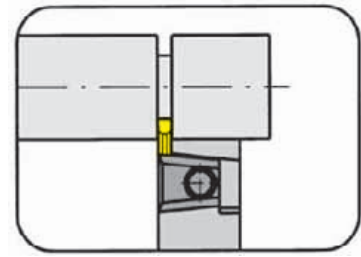

Stechtiefe bis
Spannbereich

Depth of groove up to
Clamping range

8 mm
0,5 - 1,9 mm

für Wendeschneidplatte
for Indexable insert

Typ 312
Type

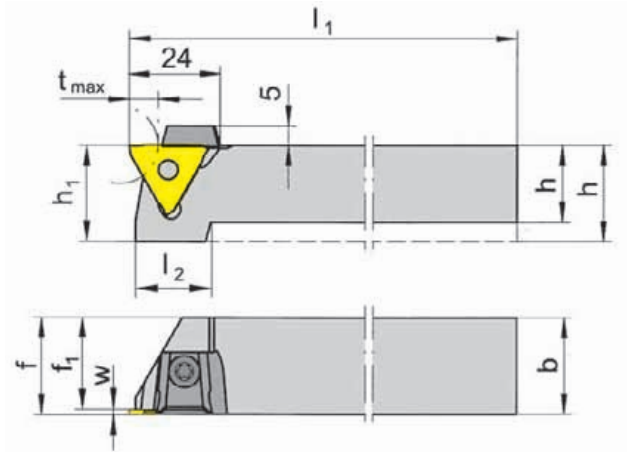

R = rechts wie gezeichnet
R = right hand version shown

L = links spiegelbildlich
L = left hand version

Bestellnummer Part number	h	b	l ₁	l ₂	h ₁	f ₁	f	t _{max}	Größe Size	Spannbereich Clamping range
R/L391.1212.01	12	12	100	21	21	10,5	f ₁ +w-a ₁	8	01	0,5-1,9
R/L391.1616.01	16	16	125	21	21	14,5	f ₁ +w-a ₁	8	01	0,5-1,9
R/L391.2020.01	20	20	125	21	21	18,5	f ₁ +w-a ₁	8	01	0,5-1,9
R/L391.2525.01	25	25	150	-	25	23,8	f ₁ +w-a ₁	8	01	0,5-1,9

Ausführung R oder L angeben
State R or L version

w, a₁ siehe WSP
w, a₁ see indexable inserts

Abmessungen in mm
Dimensions in mm

Weitere Abmessungen auf Anfrage
Further sizes upon request

t_{max} nur bei Werkstück-Ø ≤ 20 mm erreichbar.
t_{max} can be reached only with workpiece Ø ≤ 20 mm

Das Anzugsdrehmoment der Schrauben finden Sie in den Technischen Hinweisen.
For torque specification of the screw, please see Technical Instructions.

Ersatzteile

Spare Parts

Klemmhalter Toolholder	Spannelement Clamping element	TORX PLUS®-Schlüssel TORX PLUS® Wrench	Inbus-Schlüssel Wrench
R/L391.1212.01	12.3	T10PL	
R/L391.1616.01	14.4	T15PQ	
R/L391....	16.4		SW3,0 DIN911

Abstechen

Parting Off



Wendeschneidplatte

Indexable insert

312

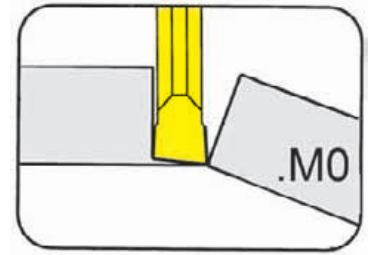

Stechtiefe bis Stechbreite	Depth of groove up to Width of groove	8 mm 1,2-1,5 mm
-------------------------------	--	--------------------

für Klemmhalter
for Toolholder

Typ 360
Type 368
391

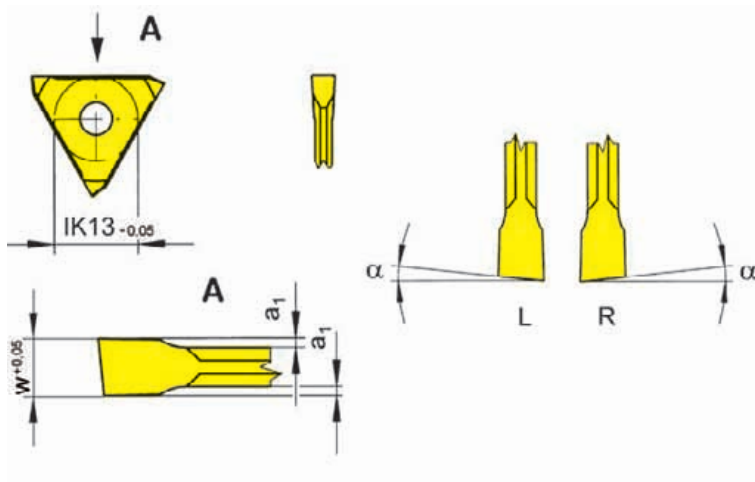

R = rechts wie gezeichnet
R = right hand version shown

L = links spiegelbildlich
L = left hand version

Bestellnummer Part number	w	t _{max}	α	a ₁	Größe Size	K10	EG35	TF45
R/L312.0512.M0	1,2	8	5°	0,2	01	Δ/Δ	▲/▲	▲/Δ
R/L312.0515.M0	1,5	8	5°	0,2	01	▲/Δ	▲/▲	▲/▲

▲ ab Lager / on stock Δ 4 Wochen / 4 weeks x auf Anfrage / upon request

● empfohlen / recommended

o bedingt einsetzbar / alternative recommendation

- nicht geeignet / not suitable

■ unbeschichtete HM-Sorten / uncoated grades

■ beschichtete HM-Sorten / coated grades

■ bestückt/Cermet / brazed/Cermet

Abmessungen in mm

Dimensions in mm

Ausführung R oder L angeben

State R or L version

P	●	●	●
M	o	●	●
K	●	o	●
N	●	-	●
S	o	-	●
H	-	-	-

HM-Sorten
Carbide grades

Abstechen

Parting Off



Wendeschneidplatte

Indexable insert

312

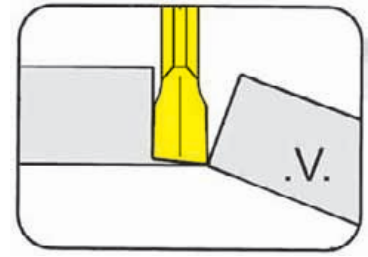

Stechtiefe bis Stechbreite	Depth of groove up to Width of groove	8 mm 1,2-2 mm
-------------------------------	--	------------------

für Klemmhalter
for Toolholder

Typ 360
Type 368
391

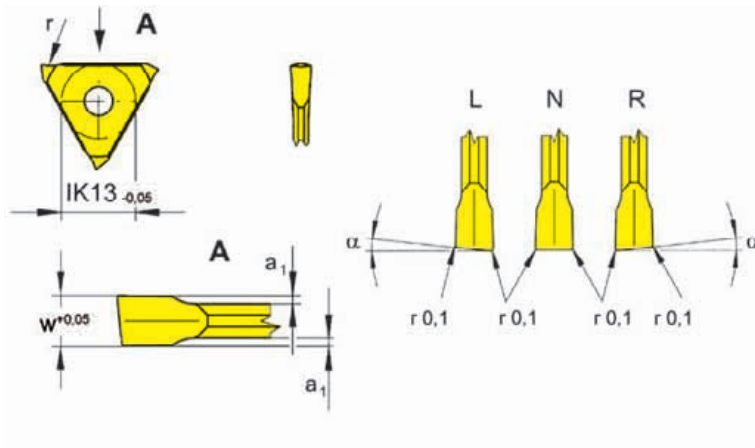

R = rechts wie gezeichnet
R = right hand version shown

L = links spiegelbildlich
L = left hand version

Bestellnummer Part number	w	α	a ₁	Größe Size	TF45	TH35
312.0012.V1	1,2	0°	0,2	01	▲	
R/L312.0512.V1	1,2	5°	0,2	01	▲/Δ	
312.0015.V1	1,5	0°	0,2	01	▲	
R/L312.0515.V1	1,5	5°	0,2	01	▲/▲	
R/L312.0520.V2	2,0	5°	0,2	01		▲/▲

▲ ab Lager / on stock Δ 4 Wochen / 4 weeks x auf Anfrage / upon request

● empfohlen / recommended

o bedingt einsetzbar / alternative recommendation

- nicht geeignet / not suitable

■ unbeschichtete HM-Sorten / uncoated grades

■ beschichtete HM-Sorten / coated grades

■ bestückt/Cermet / brazed/Cermet

Abmessungen in mm

Dimensions in mm

Ausführung R oder L angeben

State R or L version

P	•	•
M	•	•
K	•	•
N	•	•
S	•	•
H	-	-

HM-Sorten
Carbide grades



Abstechen

Parting Off



Wendeschneidplatte

Indexable insert

312

mit runder Spanleitstufe
with round chip breaker

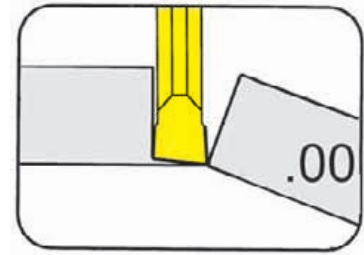

Stechtiefe bis	Depth of groove up to	8 mm
Stechbreite	Width of groove	0,5-1,5 mm

für Klemmhalter
for Toolholder

Typ 360
Type 368
391

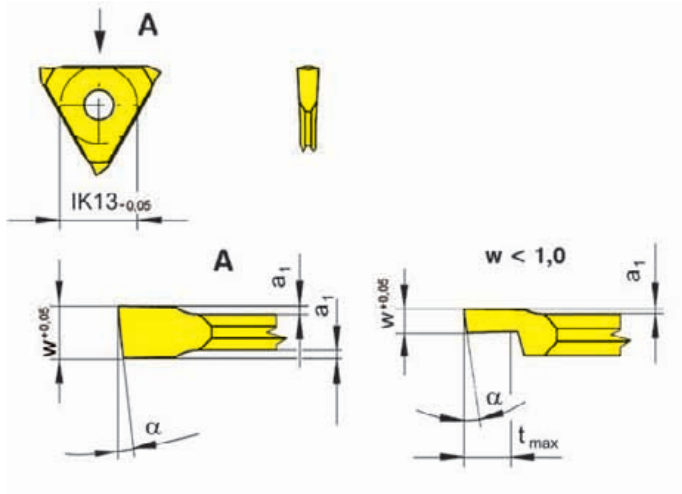

R = rechts wie gezeichnet
R = right hand version shown

L = links spiegelbildlich
L = left hand version

Bestellnummer Part number	w	t _{max}	α	a ₁	Größe Size	K10	EG35	EG55	H20	P20	TC92	TF45	TF46	TI25	TN32	TN35
R/L312.0805.00	0,5	1,0	8°	0,1	01		▲▲					▲▲				
R/L312.0808.00	0,8	1,5	8°	0,1	01		▲▲					▲▲				
R/L312.0510.00	1,0	8,0	5°	0,1	01		▲▲					▲▲				
R/L312.1210.00	1,0	8,0	12°	0,1	01		▲▲					▲▲		ΔΔ		▲/▲
R/L312.0512.00	1,2	8,0	5°	0,2	01		▲▲					▲▲				
R/L312.0515.00	1,5	8,0	5°	0,2	01	▲/x	▲/▲	▲/x	Δ/x	▲/x	Δ/x	▲/▲	▲/x		▲/x	

- ▲ ab Lager / on stock Δ 4 Wochen / 4 weeks x auf Anfrage / upon request
- empfohlen / recommended
- o bedingt einsetzbar / alternative recommendation
- nicht geeignet / not suitable
- unbeschichtete HM-Sorten / uncoated grades
- beschichtete HM-Sorten / coated grades
- bestückt/Cermet / brazed/Cermet

Abmessungen in mm
Dimensions in mm
Ausführung R oder L angeben
State R or L version

P	●	●	●	●	●	●	●	●	●	●	●	●	●	●	●	●
M	o	●	o	o	-	-	●	o	●	-	-	o	●	-	-	o
K	●	o	o	-	-	-	●	●	●	●	●	●	●	●	●	●
N	●	-	-	-	-	-	●	●	●	●	●	●	●	●	●	●
S	o	-	-	-	-	-	o	o	o	o	o	o	o	o	o	o
H	-	-	-	-	-	-	-	-	-	-	-	-	-	-	-	-

HM-Sorten
Carbide grades

Einstechen und Abstechen

Grooving and Parting Off



Wendeschneidplatte

Indexable insert

312

mit runder Spanleitstufe
with round chip breaker

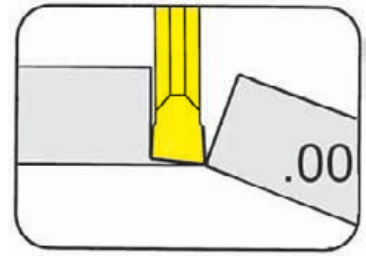

Stechtiefe bis Stechbreite	Depth of groove up to Width of groove	5 mm 1,07-1,44 mm
-------------------------------	--	----------------------

für Klemmhalter
for Toolholder

Typ 360
Type 368
391

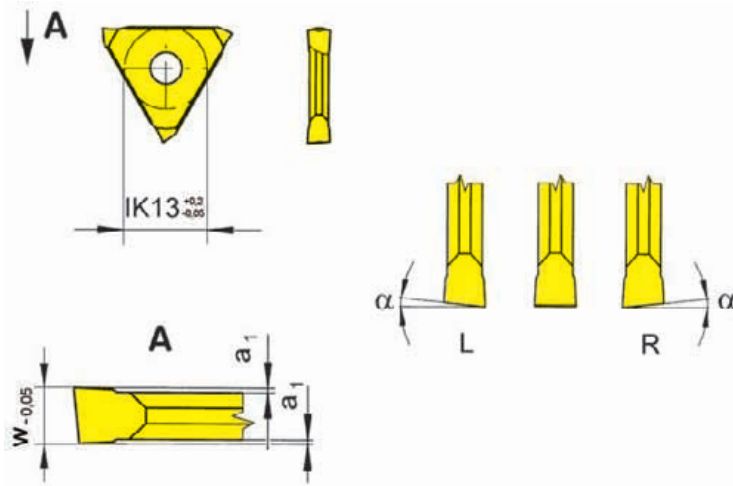

R = rechts wie gezeichnet
R = right hand version shown

L = links spiegelbildlich
L = left hand version

Bestellnummer Part number	w	α	a_1	Größe Size	K10	EG35	EG55	H20	P20	TC92	TF45	TF46	TI25	TN32	TN35
312.0100.00	1,07	-	0,09	01	▲		▲	▲	▲		▲	▲		▲	▲
312.0130.00	1,44	-	0,20	01	▲		▲		▲	▲	▲	▲		▲	▲
R/L312.0614.00	1,44	6°	0,20	01		▲/▲					▲/▲	▲/▲	▲/▲		▲/▲
▲ ab Lager / on stock Δ 4 Wochen / 4 weeks x auf Anfrage / upon request					P	●	●	●	●	●	●	●	●	●	●
● empfohlen / recommended					M	○	●	○	○	-	●	○	●	-	●
○ bedingt einsetzbar / alternative recommendation					K	●	○	○	-	-	●	●	●	-	●
- nicht geeignet / not suitable					N	●	-	-	-	-	●	●	●	-	●
■ unbeschichtete HM-Sorten / uncoated grades					S	○	-	-	-	-	○	○	●	-	●
■ beschichtete HM-Sorten / coated grades					H	-	-	-	-	-	-	-	-	-	-
■ bestückt/Cermet / brazed/Cermet															

Abmessungen in mm
Dimensions in mm

Ausführung R oder L angeben
State R or L version

HM-Sorten
Carbide grades

Außenbearbeitung:

für Klemmhalter Typ 360 rechte WSP in linken, linke WSP in rechten Klemmhaltern verwenden.

External machining:

for Toolholder type 360 use right hand inserts in left hand toolholders and left hand inserts in right hand toolholders

Abstechen von Wellen
parting off solid bars

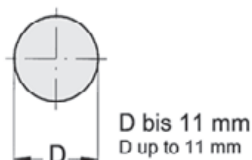

Abstechen von Ringen
parting off tubes

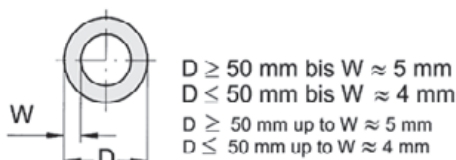

Einstechen und Abstechen

Grooving and Parting Off



Wendeschneidplatte

Indexable insert

312

mit runder Spanleitstufe
with round chip breaker

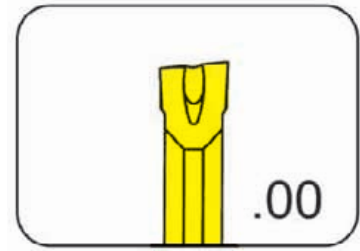

Stechtiefe bis Stechbreite	Depth of groove up to Width of groove	5 mm 1,44-2,29 mm
-------------------------------	--	----------------------

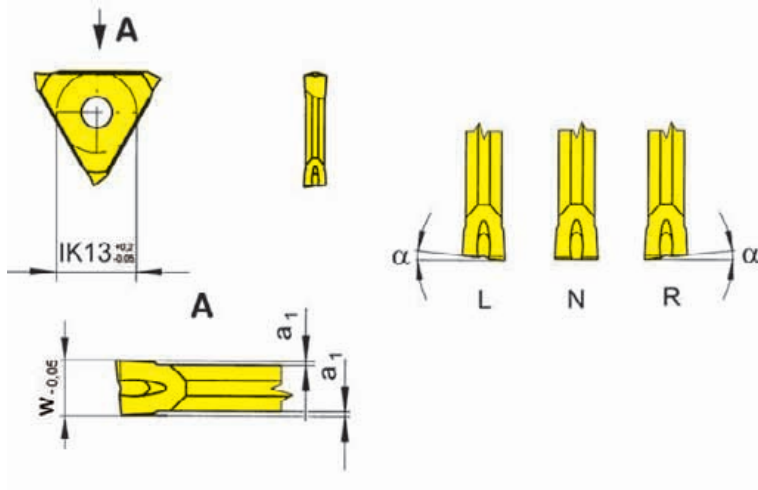

für Klemmhalter
for Toolholder

Typ 360
Type 368
391

R = rechts wie gezeichnet
R = right hand version shown

L = links spiegelbildlich
L = left hand version

Bestellnummer Part number	w	α	a ₁	Größe Size	HM-Sorten / Carbide grades							
					MG12	EG55	P20	TC92	TF45	TN32	TN35	
N312.0014.00	1,44	0°	0,2	02		▲			▲	▲		
N312.0018.00	1,99	0°	0,2	02		▲		▲	▲	▲	▲	
N312.0021.00	2,29	0°	0,2	02		▲	▲	▲	▲			▲
R/L312.0514.00	1,44	5°	0,2	02		▲/▲	▲/▲		▲/▲			
R/L312.0518.00	1,99	5°	0,2	02		▲/▲	▲/▲	▲/▲		▲/▲	▲/▲	
R/L312.0521.00	2,29	5°	0,2	02		▲/▲	▲/▲	▲/▲		▲/▲	▲/▲	

▲ ab Lager / on stock Δ 4 Wochen / 4 weeks x auf Anfrage / upon request

● empfohlen / recommended

○ bedingt einsetzbar / alternative recommendation

- nicht geeignet / not suitable

□ unbeschichtete HM-Sorten / uncoated grades

■ beschichtete HM-Sorten / coated grades

■ bestückt/Cermet / brazed/Cermet

Abmessungen in mm

Dimensions in mm

Ausführung R oder L angeben

State R or L version

Außenbearbeitung:

für Klemmhalter Typ 360 rechte WSP in linken, linke WSP in rechten Klemmhaltern verwenden.

External machining:

for Toolholder type 360 use right hand inserts in left hand toolholders and left hand inserts in right hand toolholders

Abstechen von Wellen
parting off solid bars

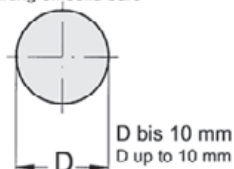

Abstechen von Rohren
parting off tubes

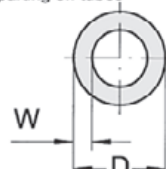

D ≥ 50 mm bis W ≈ 5 mm
D ≤ 50 mm bis W ≈ 4 mm
D ≥ 50 mm up to W ≈ 5 mm
D ≤ 50 mm up to W ≈ 4 mm

Abstechen

Parting Off



Wendeschneidplatte

Indexable insert

S312

mit gesinterter Geometrie
with sintered geometries

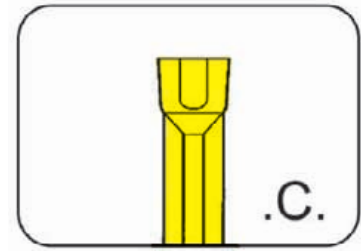

Stechtiefe bis
Stechbreite

Depth of groove up to
Width of groove

5 mm
2-3 mm

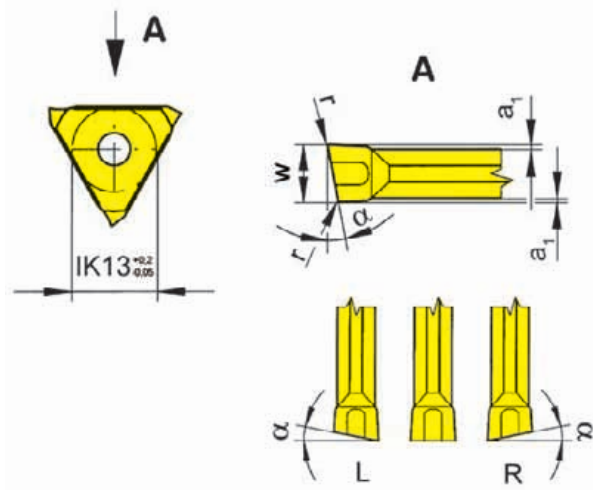

R = rechts wie gezeichnet
R = right hand version shown

L = links spiegelbildlich
L = left hand version

für Klemmhalter
for Toolholder

Typ 360
Type 368
391

Geometrie .C
Geometry .C

Bestellnummer Part number	w	r	α	a_1	Größe Size	EG55	TF46	TI25
S312.0200.C2	2,0	0,2	0°	0,25	02	▲	▲	▲
R/LS312.0520.C2	2,0	0,2	5°	0,25	02	▲/▲	▲/▲	▲/▲
S312.0250.C2	2,5	0,2	0°	0,25	02	▲	▲	▲
R/LS312.0525.C2	2,5	0,2	5°	0,25	02	▲/▲	▲/▲	▲/▲
S312.0300.C2	3,0	0,2	0°	0,25	03	▲	▲	▲
R/LS312.0530.C2	3,0	0,2	5°	0,25	03	▲/▲	▲/▲	▲/▲

▲ ab Lager / on stock Δ 4 Wochen / 4 weeks x auf Anfrage / upon request

● empfohlen / recommended

o bedingt einsetzbar / alternative recommendation

- nicht geeignet / not suitable

■ unbeschichtete HM-Sorten / uncoated grades

■ beschichtete HM-Sorten / coated grades

■ bestückt/Cermet / brazed/Cermet

Abmessungen in mm

Dimensions in mm

Ausführung R oder L angeben

State R or L version

Wendeschneidplatten sind in rechten und linken Klemmhaltern verwendbar.

Indexable inserts can be used in right and left hand toolholders.

P	●	●	●
M	o	o	●
K	o	●	●
N	-	●	●
S	-	o	●
H	-	-	-

HM-Sorten
Carbide grades

T

Abstechen

Parting Off



Wendeschneidplatte

Indexable insert

S312

mit gesinterter Geometrie
with sintered geometries

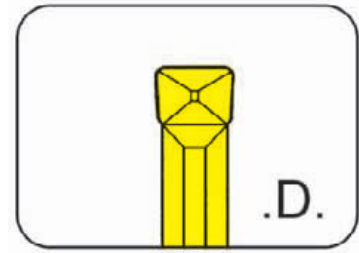

Stechtiefe bis Stechbreite	Depth of groove up to Width of groove	5 mm 2-3 mm
-------------------------------	--	----------------

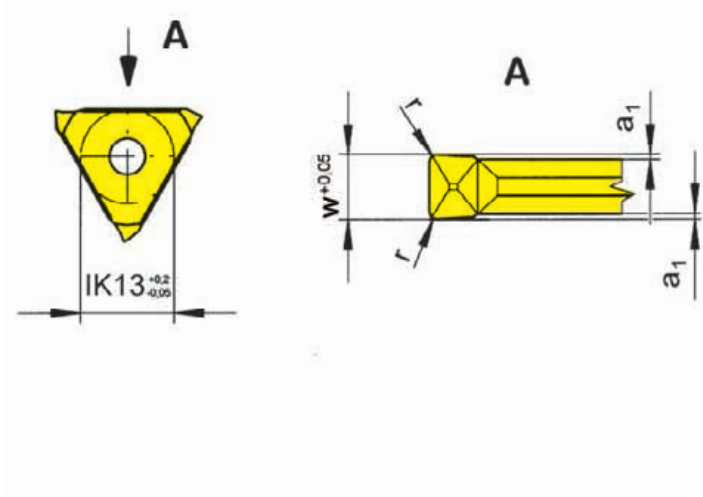

für Klemmhalter
for Toolholder

Typ 360
Type 368
391

Geometrie .D
Geometry .D

Bestellnummer Part number	w	r	a ₁	Größe Size	AL96	AS62	AS66	EG56	TC92	TF45	TF46	Ti25	TN32
S312.0200.D2	2,0	0,2	0,25	02	Δ	▲	▲	▲	▲	Δ	Δ	▲	▲
S312.0200.D4	2,0	0,4	0,25	02	Δ	▲	▲	▲	▲	Δ	Δ	▲	▲
S312.0250.D2	2,5	0,2	0,25	02	Δ	▲	▲	▲	▲	▲	▲	▲	▲
S312.0250.D4	2,5	0,4	0,25	02	Δ	▲	▲	▲	▲	▲	▲	▲	▲
S312.0300.D2	3,0	0,2	0,25	03	Δ	▲	▲	▲	▲	▲	▲	▲	▲
S312.0300.D4	3,0	0,4	0,25	03	Δ	▲	▲	▲	▲	Δ	Δ	▲	▲
▲ ab Lager / on stock Δ 4 Wochen / 4 weeks x auf Anfrage / upon request					P	●	●	●	●	●	●	●	●
● empfohlen / recommended					M	-	-	o	o	-	●	o	-
o bedingt einsetzbar / alternative recommendation					K	●	-	●	o	-	●	●	-
- nicht geeignet / not suitable					N	●	-	●	-	-	●	●	-
■ unbeschichtete HM-Sorten / uncoated grades					S	-	-	o	-	-	●	o	-
■ beschichtete HM-Sorten / coated grades					H	-	-	-	-	-	-	-	-
■ bestückt/Cermet / brazed/Cermet													

Abmessungen in mm
Dimensions in mm

HM-Sorten
Carbide grades

T

Abstechen

Parting Off



Wendeschneidplatte

Indexable insert

S312

mit gesinterter Geometrie
with sintered geometries

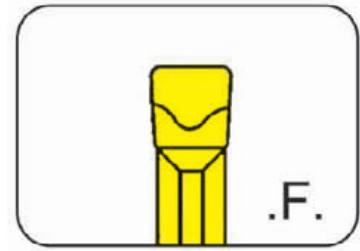

Stechtiefe bis
Stechbreite

Depth of groove up to
Width of groove

5 mm
2-2,5 mm

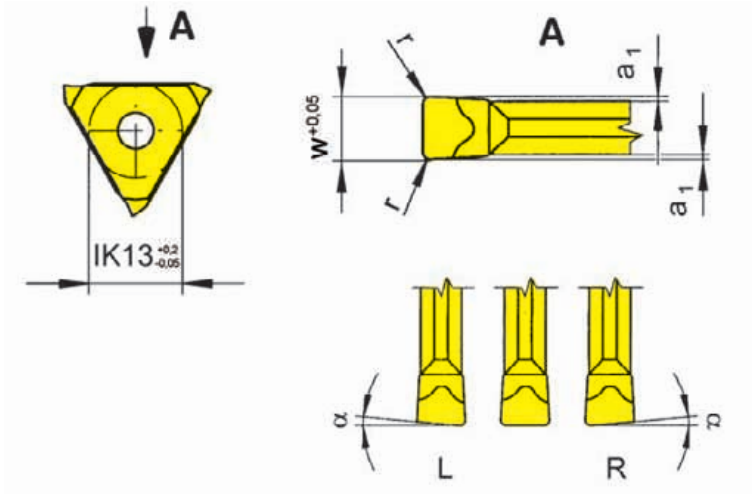

R = Rechtsausführung
R = right hand version

L = links spiegelbildlich
L = left hand version

für Klemhalter
for Toolholder

Typ 360
Type 368
391

Geometrie .F
Geometry .F

Bestellnummer Part number	w	r	α	a ₁	Größe Size	AL96	EG56	TC92	TF45	TF46	TI25
R/LS312.0520.F2	2,0	0,2	5°	0,25	02		Δ/Δ			▲/Δ	▲/▲
S312.0200.F2	2,0	0,2	0°	0,25	02	Δ	▲	Δ	Δ	▲	▲
R/LS312.0525.F2	2,5	0,2	5°	0,25	02		▲/Δ			▲/Δ	▲/▲
S312.0250.F2	2,5	0,2	0°	0,25	02	Δ	Δ	Δ	Δ	▲	▲

▲ ab Lager / on stock Δ 4 Wochen / 4 weeks x auf Anfrage / upon request

● empfohlen / recommended

o bedingt einsetzbar / alternative recommendation

- nicht geeignet / not suitable

■ unbeschichtete HM-Sorten / uncoated grades

■ beschichtete HM-Sorten / coated grades

■ bestückt/Cermet / brazed/Cermet

Abmessungen in mm

Dimensions in mm

Ausführung R oder L angeben

State R or L version

P	●	●	●	●	●	●
M	-	o	-	●	o	●
K	●	o	-	●	●	●
N	●	-	-	●	●	●
S	-	-	-	●	o	●
H	-	-	-	-	-	-

HM-Sorten
Carbide grades

T

Klemmhalter
Toolholder
H316

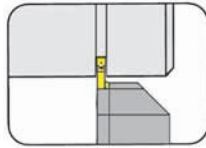

Seite/Page
T132

Wendeschneidplatte
Indexable insert
S316

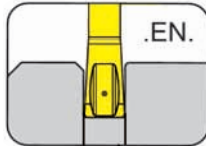

Seite/Page
T133

T

316



T

**Klemmhalter mit
Schneidplatten**

Stechbreite 2,0 - 3,0 mm

**Toolholder with
Inserts**

Width of groove 2,0 - 3,0 mm

Einstecken (außen)

Grooving (external)



Klemmhalter

Toolholder

H316

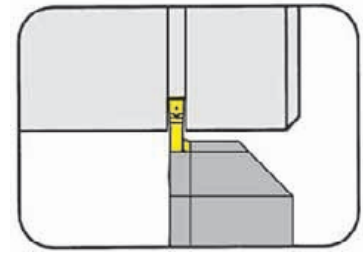

Stechtiefe bis Spannbereich	Depth of groove up to Clamping range	8 mm 1,5 - 3,0 mm
--------------------------------	---	----------------------

für Wendeschneidplatte
for Indexable insert

Typ S316
Type

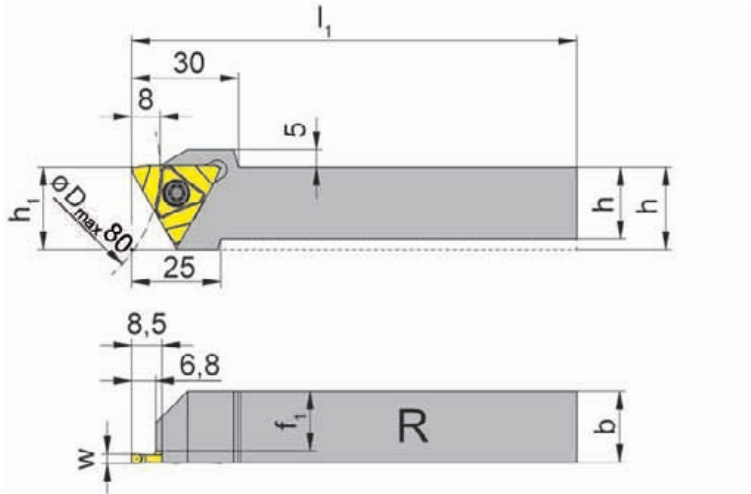

R = rechts wie gezeichnet
R = right hand version shown

L = links spiegelbildlich
L = left hand version

Bestellnummer Part number	h	b	l ₁	h ₁	f ₁	Größe Size
R/LH316.1616.S3.03	16	16	125	23	12,7	03
R/LH316.2020.S3.03	20	20	125	23	16,7	03
R/LH316.2525.S3.03	25	25	150	25	21,7	03
R/LH316.3225.S3.03	32	25	150	32	21,7	03

Ausführung R oder L angeben
State R or L version

w siehe WSP
w see indexable inserts

Abmessungen in mm
Dimensions in mm

Weitere Abmessungen auf Anfrage
Further sizes upon request

Das Anzugsdrehmoment der Schrauben finden Sie in den Technischen Hinweisen.
For torque specification of the screw, please see Technical Instructions.

Ersatzteile

Spare Parts

Klemmhalter Toolholder	Spannschraube Screw	TORX PLUS®-Schlüssel TORX PLUS® Wrench
R/LH316...	5.12T20P	T20PQ

Wendeschneidplatte

Indexable insert

S316

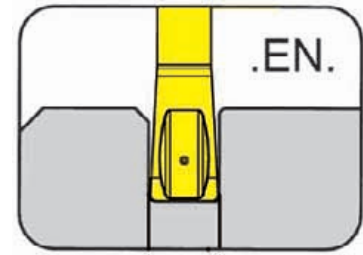

Stechtiefe bis Stechbreite	Depth of groove up to Width of groove	8 mm 2-3 mm
-------------------------------	--	----------------

präzisionsgesintert
precision sintered

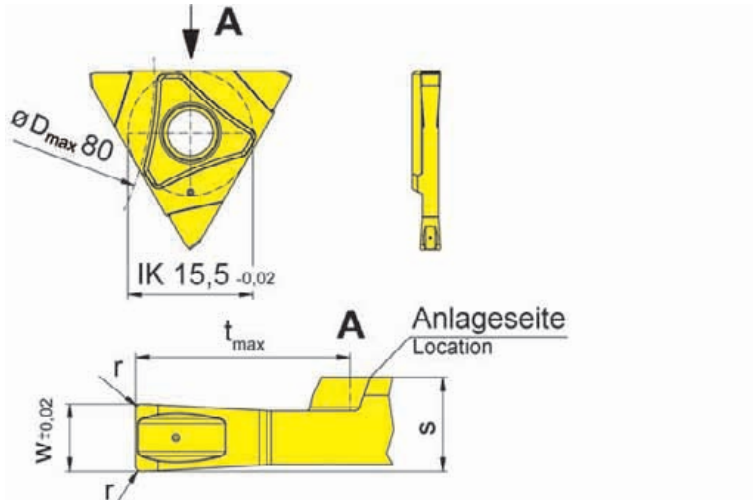

R = rechts wie gezeichnet
R = right hand version shown

L = links spiegelbildlich
L = left hand version

für Klemmhalter
for Toolholder

Typ H316...S3.03
Type

Wechselgenauigkeit
Länge $\pm 0,02$ mm
Indexability length $\pm 0,02$ mm

Bestellnummer Part number	w	r	t_{max}	s	Größe Size	AS6G
R/LS316.0200.EN2	2,0	0,2	8	3,5	03	▲▲
R/LS316.0250.EN2	2,5	0,2	8	3,5	03	▲▲
R/LS316.0300.EN2	3,0	0,2	8	3,5	03	▲▲

▲ ab Lager / on stock Δ 4 Wochen / 4 weeks x auf Anfrage / upon request

● empfohlen / recommended

o bedingt einsetzbar / alternative recommendation

- nicht geeignet / not suitable

■ unbeschichtete HM-Sorten / uncoated grades

■ beschichtete HM-Sorten / coated grades

■ bestückt/Cermet / brazed/Cermet

Abmessungen in mm

Dimensions in mm

Ausführung R oder L angeben

State R or L version

HM-Sorten
Carbide grades

Außenbearbeitung:

Rechte WSP in rechten, linke WSP in linken Klemmhaltern verwenden.

External machining:

Use right hand inserts in right hand toolholders and left hand inserts in left hand toolholders



T



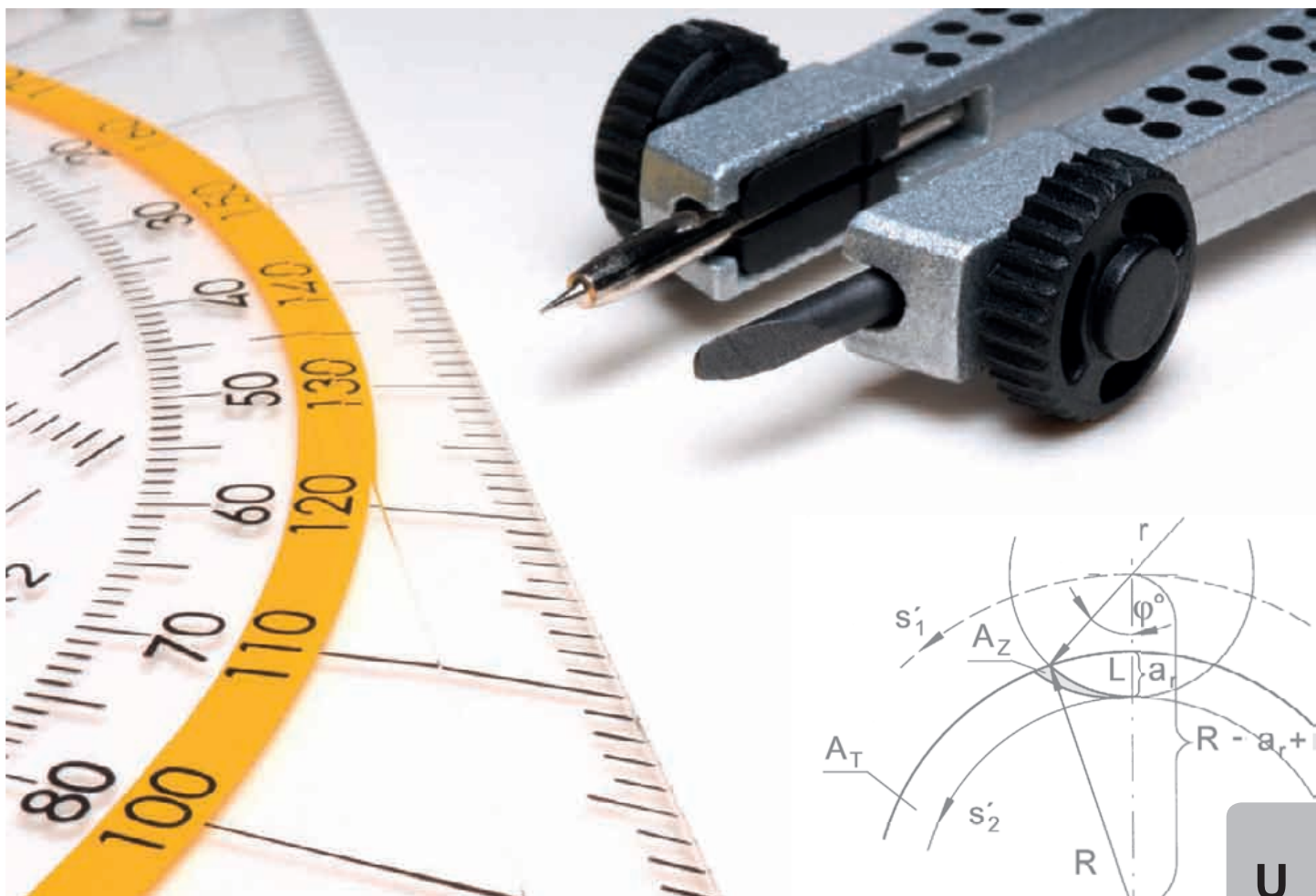

Inhalt/Summary	Seite/Page
Anzugsmomente	U2-U6
Torque Specification	
Technische Informationen	U7-U18
Technical Information	
Geometrien und Vorschübe	U19-U33
Geometries and feed rates	
Schnittdaten	U34-U37
Cutting Data	
HM-Sorten für Ein-Abstechen	U38-U39
Carbide grades for grooving and parting off	
Beschreibung HM-Sorten	U40-U42
Description carbide grades	

Nachstehende Drehmomente sind für die Spannschrauben zulässig. Wir empfehlen keine zusätzlichen Gleitmittel wie Kupferpaste oder ähnliches für die Schrauben zu verwenden.

Following torques are allowed for screws of inserts. We recommend to use no additional gliding means (such as copper paste) for screws.

Die passenden Drehmomentschlüssel finden Sie im Kapitel Zubehör.

For torque screw drivers please see chapter additional equipment.

Typ type	Schraube Screw	M _d Nm	Schlüssel Clamping wrench	Klinge Blade
050	030.0518.T20P	5,0	T20PQ	DT20PK
208	6.16	3,0	SW3DIN911	DSW30K
210	218.3	6,5 - 7,0	SW6DIN911	DSW60K
210...09/...K9	5.32T15P	4,5 - 5,0	T15PQ	DT15PK
211	6.19	3,0	SW3DIN911	DSW30K
213	218.3	6,5 - 7,0	SW6DIN911	DSW60K
213...09	5.32T15P	4,5 - 5,0	T15PQ	DT15PK
213...IK	DIN912-M6x14	6,0	SW5DIN911	DSW50K
214	218.3	6,5 - 7,0	SW6DIN911	DSW60K
214...09	5.32T15P	4,5 - 5,0	T15PQ	DT15PK
218	218.3	6,5 - 7,0	SW6DIN911	DSW60K
218...0.03.IK - 0.05.IK 218...2.03.IK - 2.05.IK	6.23.T25P	7,0	T25PQ	DT25PK
218...09/...K9	5.32T15P	4,5 - 5,0	T15PQ	DT15PK
219	218.3	6,5 - 7,0	SW6DIN911	DSW60K
219...09	5.32.3T15P	4,5 - 5,0	T15PQ	DT15PK
221	6.20.70P	5,0	T20PQ	DT20PK
225	218.3	6,5 - 7,0	SW6DIN911	DSW60K
226	218.3	6,5 - 7,0	SW6DIN911	DSW60K
226...09	5.32T15P	4,5	T15PQ	DT15PK
226...0.03.IK - 0.05.IK 226...2.03.IK - 2.05.IK	6.23.T25P	7,0	T25PQ	DT25PK
226.2608.../3208...	4.15T15P	5,0	T15PQ	DT15PQ
228	6.20.70P	5,0	T20PQ	DT20PK/DT20PQ
230	5.14	2,0 - 2,5	SW2,5DIN911	DSW25K
232	5.14	2,0 - 2,5	SW2,5DIN911	DSW25K
233	5.14	2,0 - 2,5	SW2,5DIN911	DSW25K
234	5.14	2,0 - 2,5	SW2,5DIN911	DSW25K
235	5.14	2,0 - 2,5	SW2,5DIN911	DSW25K
240	5.14	2,0 - 2,5	SW2,5DIN911	DSW25K
245	51.27.984P	4,0	T15PQ	DT15PK
248	5.14	2,0 - 2,5	SW2,5DIN911	DSW25K
250	5.14	2,0 - 2,5	SW2,5DIN911	DSW25K
253	5.14	2,0 - 2,5	SW2,5DIN911	DSW25K

Typ type	Schraube Screw	M _d Nm	Schlüssel Clamping wrench	Klinge Blade
254	5.14	2,0 - 2,5	SW2,5DIN911	DSW25K
255	5.14	2,0 - 2,5	SW2,5DIN911	DSW25K
257...05	218.3	6,5	SW6DIN911	DSW60K
257...07/...09	5.32.3T15P	5,0	T15PQ	DT15PK
309	6.25	4,0 - 4,5	SW3DIN911	DSW30K
330	5.12T20P	6,0 - 6,5	T20PQ	DT20PK/DT20PQ
333	5.12T20P	6,0 - 6,5	T20PQ	DT20PK/DT20PQ
340	6.25	4,0 - 4,5	SW3DIN911	DSW30K
356...3/...5	5.12T20P	6,0 - 6,5	T20PQ	DT20PK/DT20PQ
356...45.03	5F.08T20P	5,0	T20PQ	DT20PK/DT20PQ
356...6/...7/...10/...2.13 356...2.13.IK/...2.15.IK	5.15T20P	6,0 - 6,5	T20PQ	DT20PK/DT20PQ
357	5.12T20P	6,0 - 6,5	T20PQ	DT20PK/DT20PQ
360	6.25	4,0 - 4,5	SW3DIN911	DSW30K
361	030.0422.T10P	3,0	T10PL	DT10PK
368	4.15T15P	4,0	T15PQ	DT15PK
368...10.01	030.0422.T10	4,0	T10PL	DT10PK
369	6.25	4,0 - 4,5	SW3DIN911	DSW30K
390	6.25	4,0 - 4,5	SW3DIN911	DSW30K
391.1212...	030.0422.T10P	3,0	T10PL	DT10PK
391.1616...	5.32.3T15P	5,0	T15PQ	DT15PK
391.2...	6.25	4,0 - 4,5	SW3DIN911	DSW30K
974	030.3509.T15P	3,0	T15PQ	DT15PK
B105/BU105 B105KM BU105	6.075T15P	5,0	T15PQ	DT15PK
B105.A022...	030.0422.T10P	3,0	T10PL	DT10PK
B105MD	DIN913-M5x5	1,0	SW2,5DIN911	DSW25K
B108 B108KM	2.6.5T8EP	1,2	T8PL	DT8PK
B110	6.075T15P	5,0	T15PQ	DT15PK
B111	3.5.12T10EP	3,0	T10PL	DT10PK
B114	4.12T15EP	5,0	T15PQ	DT15PK
B119	5.11T15P	2,5 - 3,0	T15PL	DT15PK
B209	3.5.12T10EP	2,5	T10PQ	DT10PK
B223	5.11T15P	2,5 - 3,0	T15PL	DT15PK
B223...K2	4.09T15P	2,5 - 3,0	T15PL	DT15PK
B224.00...	5.13T20P	6,0 - 6,5	T20PQ	DT20PK/DT20PQ
B224.45... B224.60...	6.14T25P	7,0	T25PQ	DT25PK/DT25PQ

Typ type	Schraube Screw	M _d Nm	Schlüssel Clamping wrench	Klinge Blade
BK224	5.13T20EP	6,0 - 6,5	T20PQ	DT20PK/DT20PQ
BK229	5.13T20EP	6,0	T20PQ	DT20PK/DT20PQ
BKT	6.075T15P	5,0 - 5,5	T15PQ	DT15PK
E223	5.11T15P	2,5 - 3,0	T15PL	DT15PK
H34T...10.IK	030.4093.T15P	3,0	T15PQ	DT15PK
H34T...20.IK	030.4010.T15P	5,0	T15PQ	DT15PK
H34T...30.IK	030.5012.T15P	6,0	T15PQ	DT15PK
H34T...40.IK	030.5012.T20P	6,0	T20PQ	DT20PK/DT20PQ
H64T...10.IK	030.4010.T15P	4,0	T15PQ	DT15PK
H64T...20.IK	030.4010.T15P	5,0	T15PQ	DT15PK
H105	6.075T15P	5,0	T15PQ	DT15PK
H100...01/...11/...21 + IK H100...02/...12/...22 + IK H100...71/...72 H100...71R/L/...72R/L	4.15T15P	5,0	T15PQ	DT15PK
H100...03/...13/...23 H100...04/...14/...24 H100...15 H100...1.23.IK	5.17T20P	6,5	T20PQ	DT20PK/DT20PQ
H100...04.IK H100...23.IK/...24.IK H100...73.IK/...74.IK	6.23T25P	7,0	T25PQ	DT25PK/DT25PQ
H100...73R/L/...74R/L	DIN912-M5x20	4,0	SW4DIN911	DSW40K
H100...83/...84	030.505P.0718	5,0	T15PQ	DT15PK
H100...83R/L/N/...84R/L/N	030.505P.0660	5,0	T15PQ	DT15PK
H100...93/...93R/L	030.0413.T15P	3,0	T15PQ	DT15PK
H100.2020.3.0.. H100.2525.3.0.. H100.3225.3.0./...38 H100.3225.4.0./...4.1.. H100...08/...10/...12	030.6075.T20P	5,0	T20PQ	DT20PK
H100.3232...	030.0625.T25P	7,0	T25PQ	DT25PK/DT25PQ
H100.52...	5.13T20P	5,0	T20PQ	DT20PK/DT20PQ
H117...10/...12 H117.1407.../.1439... H117.1441.../.1442...	4.09T15P	4,5 - 5,0	T15PQ	DT15PK
H117.1010.10	030.400P0227	5,0	T15PQ	DT15PK
H117...16/...32/...45 H117.1419.../.1440...	5.12T20P	6,0	T20PQ	DT20PK/DT20PQ
H117...20/...26	6.17T20P	7,0	T20PQ	DT20PK/DT20PQ
H117MD	030.400P.0227	5,0	T15PQ	DT15PK
H223	5.11T15P	2,5 - 3,0	T15PL	DT15PK

Anzugsmomente

Torque of Screws



Typ type	Schraube Screw	M _d Nm	Schlüssel Clamping wrench	Klinge Blade
H223.2608.../.3208...	4.15T15P	5,0	T15PL	DT15PK
H224	6.23T25P	6,0	T25PQ	DT25PK/DT25PQ
H224.1212.81	6.17T25P	5,0	T25PQ	DT15PK
H224.1608.02/.23/.24 H224.2608.81/.82/.83	4.15T15P	5,0	T15PQ	DT15PK
H224.2608.01/.02/.03 H224.3208.01/.02/.03	4.20T15P	4,3	T15PL	DT15PK
H224.3208.93	030.0413T15P	3,0	T15PQ	DT15PK
H224..61/..62/..63/..64+IK	4.12.T15EP	5,0	T15PQ	DT15PK
H224...65/...66/...83R	5.13.T20EP	6,5	T20PQ	DT20PK/DT20PQ
H262	030.2557.T8P	1,0	T8PL	DT8PK
H264 H264KM	3.5.12T10EP	2,5 - 3,0	T10PL	DT10PK
H274...04/...04.E	030.3509.T15P	3,0	T15PQ	DT15PK
H274...07	030.3513.T15P	3,0	T15PQ	DT15PK
H274KM	030.3509.T15P	3,0	T15PQ	DT15PK
H316	5.12T20P	6,0 - 6,5	T20PQ	DT20PK/DT20PQ
HC105	6.075T15P	5,0 - 5,5	T15PQ	DT15PK
HC105MD	DIN911-M4x5	1,0	SW2,0DIN911	SW20K
HC114	4.12T15EP	5,0	T15PQ	DT15PK
HC274KM	030.3509.T15P	3,0	T15PQ	DT15PK
HC316	5.12T20P	6,0 - 6,5	T20PQ	DT20PK/DT20PQ
KT274 KTC274	030.3509.T15P	3,0	T15PQ	DT15PK
L368	4.18T15EP	4,0	T15PQ	DT15PK
L849.0226.L...	6.23T25P	7,0	T25PQ	DT25PK/DT25PQ
LA210	218.3	6,5 - 7,0	SW6.911	DSW60K
LA226	218.3	6,5 - 7,0	SW6.911	DSW60K
LAK220	6.23T25P	7,0	T25PQ	DT25PK/DT25PQ
LAK224	5.13T20P	6,0	T20PQ	DT20PK/DT20PQ
LIK220	6.23T25P	7,0	T25PQ	DT25PK/DT25PQ
LIK224	5.13T20P	6,0	T20PQ	DT20PK/DT20PQ
LNK368	5.10T20P	6,0	T20PQ	DT20PK/DT20PQ
LNK760	5.13T20EP	6,0	T20PQ	DT20PK/DT20PQ
N849...10.00/...12.00	4.09T15P	4,5 - 5,0	T15PQ	DT15PK
N849...16.00/...32.00	5.12T20P	6,0 - 6,5	T20PQ	DT20PK/DT20PQ
N849...20.00/...26.00	6.17T20P	7,0	T20PQ	DT20PK/DT20PQ
N849...K1	DIN1835-B M10x12	6,0	SW5,0DIN911	DSW50K
NH105MD	DIN911-M4x5	1,0	SW2,0DIN911	SW20K

U

Typ type	Schraube Screw	M _d Nm	Schlüssel Clamping wrench	Klinge Blade
NK100	5.13T20P	6,5	T20PQ	DT20PK/DT20PQ
NK100.0840...	4.20T15P	4,3	T15PL	DT15PK
NK100.3215...	6.23T25P	7,0	T25PQ	DT25PK/DT25PQ
NK220	6.23T25P	7,0	T25PQ	DT25PK/DT25PQ
NK224.3215...	5.13T20P	6,0	T20PQ	DT20PK/DT20PQ
NK224.0840...	5.12T20P	6,0 - 6,5	T20PQ	DT20PK/DT20PQ
NK264	4.20T15P	4,3	T15PL	DT15PK
NK274	030.3509.T15P	3,0	T15PQ	DT15PK
NK356	5.12T20P	6,0	T20PQ	DT20PK/DT20PQ
NK360	5.12T20P	6,0	T20PQ	DT20PK/DT20PQ
NK360.0220...	5.32.3T15P	4,5 - 5,0	T15PQ	DT15PK
NK360.0840.1.01/02/03	030.0422.T10P	3,0	T10PL	DT10PK
NK360.0840.1.04	5.32.3T15P	4,5 - 5,0	T15PQ	DT15PK
NK368	030.400P.0602	4,0	T10PL	DT10PK
R76	030.3509.T15P	5,0	T15PQ	DT15PK
R849.0226.R...	6.23T25P	7,0	T25PQ	DT25PK/DT25PQ
R849...K2	DIN913-M8x12	7,0	SW5DIN911	DSW50K
RA210	218.3	6,5 - 7,0	SW6.911	DSW60K
RA226	218.3	6,5 - 7,0	SW6.911	DSW60K
RAK220	6.23T25P	7,0	T25PQ	DT25PK/DT25PQ
RAK224	5.13T20P	6,0	T20PQ	DT20PK/DT20PQ
RBA114	4.12.T15EP	5,0	T15PQ	DT15PK/DT15PQ
RIK220	6.23T25P	7,0	T25PQ	DT25PK/DT25PQ
RHC274	030.3509.T15P	5,0	T15PQ	DT15PK
RIK224	5.13T20P	6,0	T20PQ	DT20PK/DT20PQ
SB105	6.075T15P	5,0	T15PQ	DT15PQ
SB110	6.075T15P	5,0	T15PQ	DT15PQ
SH117...08	030.3509.T15P	3,5	T15PQ	DT15PK
SH117...10/...12	4.09T15P	4,5 - 5,0	T15PQ	DT15PK
SH117...16	5.12T20P	6,0 - 6,5	T20PQ	DT20PK/DT20PQ
SHM117...08	030.3509.T15P	3,5	T15PQ	DT15PK
VDI	6.075T15P	5,0	T15PQ	DT15PK

Längsdrehen Side Turning

HORN-Einsteckwerkzeuge gewährleisten auch bei Formeinstichen mit einseitigen Schnittkräften absolute Form- und Winkelgenauigkeit.

Ein Auslenken der Schneide ist drehtechnisch wünschenswert, beim Einstechen jedoch nicht vertretbar.

HORN-Grooving Tools will give you absolute accuracy of profile and angles, even when profiling with one-sided cutting forces.

A flexible cutting edge would be desirable for turning, but not useful for precision grooving.

Bitte beim Einrichten des Werkzeuges beachten:

Richten Sie das Werkzeug (Schneide) stets rechtwinklig zur Werkstückachse aus.

Please note when setting tool:

Always ensure that the tool is perpendicular to the axis of the workpiece.

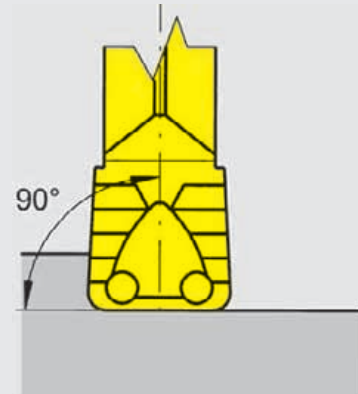

Unsachgemäße Ausrichtung:

Bei Vorschubrichtung 1 treten Vibrationen auf. Stabile oder stabil gespannte Werkstücke erhöhen die Vibrationsneigung.

Vorschubrichtung 2 ist für das DREHEN ideal und hat auf die Funktionen keine negativen Auswirkungen.

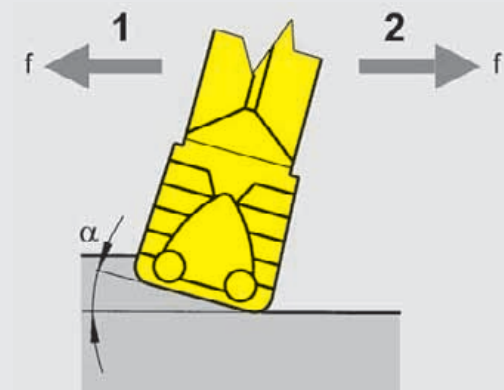

Improper setting:

Feed direction 1 will create vibrations. The tendency to vibrate will increase on rigid workpieces.

Feed direction 2 is suitable for turning and will have no negative effects to the operation.

Längsdrehen Side Turning

Einstechwerkzeuge sind kein Ersatz für Drehwerkzeuge mit DIN-Wendepplatten. Bei bestimmten Arbeitsgängen, z.B. beim Auskesseln, können Werkzeugwechselzeiten und damit die Hauptzeit durch Einstechwerkzeuge drastisch gesenkt werden.

The grooving tool should not be seen as a replacement for a turning tool with ISO-inserts. On certain operations, for instance grooving and turning can reduce the number of tool changes and offer reduced cycle time.

Schneidbreite:

Die Breiten 4, 5 und 6 mm sind bevorzugt für das Längsdrehen zu verwenden. Die Kontur und Stabilität des Werkstücks entscheidet über die Schneidbreite. Der größtmögliche Eckenradius ist zu wählen.

Width of insert:

The width 4, 5 and 6 mm are recommended for side turning. The profile and rigidity of the workpiece determines the width of insert. Always choose the largest possible edge radius.

Breite Width	4 mm	5 mm	6 mm	
$a_{p \max}$ f	2.8 0.15 - 0.30	3.5 0.15 - 0.40	4.0 0.15 - 0.40	.3.
$a_{p \max}$ f	2.8 0.15 - 0.30	3.5 0.15 - 0.50	4.0 0.15 - 0.60	.5.
$a_{p \max}$ f	2.8 0.10 - 0.25	3.5 0.10 - 0.30	4.0 0.10 - 0.30	.A.

Schnitttiefe a_p :

Die Schnitttiefe richtet sich nach der Breite der Schneidplatte, dem zu zerspanenden Werkstoff und der Steifigkeit des Werkstücks und wird begrenzt durch die Schneidkantenlänge.

Als Faustformel gilt: $a_{p \max} = w \times 0,7$ oder max. 3,0 mm
 $a_{p \min} = \text{Eckenradius (r)}$

Die kleinste Schnitttiefe $a_{p \min}$ entspricht dem Eckenradius der Schneidplatte. Bei geringerer Schnitttiefe entstehen ungünstige feine Bandspäne.

Maximaler Vorschub f_{\max} :

Als Faustformel gilt: $f_{\max} = w \times 0,1$

Cutting depth a_p :

When side turning the cutting depth is dependent upon the width of insert as well as on the material and the rigidity of the workpiece. The max. depth would be limited by the length of the cutting edge.

Rule of thumb for calculation: $a_{p \max} = w \times 0,7$ or max. 3,0 mm
 $a_{p \min} = \text{corner radius (r)}$

The smallest cutting depth $a_{p \min}$ is governed by the edge radius of the insert. Cutting depth below the corner radius will create poor cutting conditions.

Max. feed rate f_{\max} :

Rule of thumb for calculation: $f_{\max} = w \times 0,1$

Längsdrehen

Side Turning

Bearbeiten zwischen Schultern

Side turning between shoulders

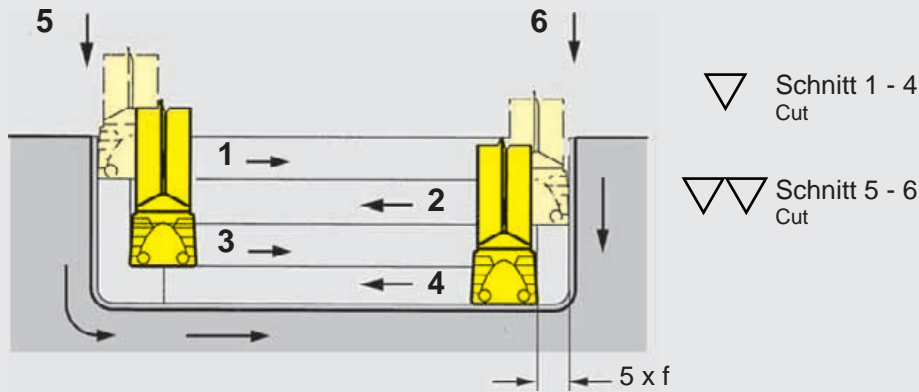

Beim Längsdrehen im Bereich einer Schulter ist stets an der Schulter zu beginnen. Wird zur Schulter hin gedreht, kann diese den Spanablauf ungünstig beeinflussen und es besteht die Gefahr des Plattenbruchs.

Beim Auskammern empfiehlt sich, wie vorstehend gezeigt vorzugehen. Schnitt 2 und weitere erfordern einen Abstand von $5 \times f$. So wird vermieden, dass der Span unter die Platte gelenkt wird.

Always start at the shoulder when side turning, towards shoulder. An operation towards the shoulder will influence the run off the chip and creates the risk of insert breaking. Grooving and turning is recommended as shown.

Cut 2 and subsequent cuts leave a distance of $5 \times f$ to the shoulder. This cut width will help to prevent swarf being trapped under the advancing cutting edge.

Fasen von Nuten mit Standard-Schneidplatten

Chamfering with standard inserts

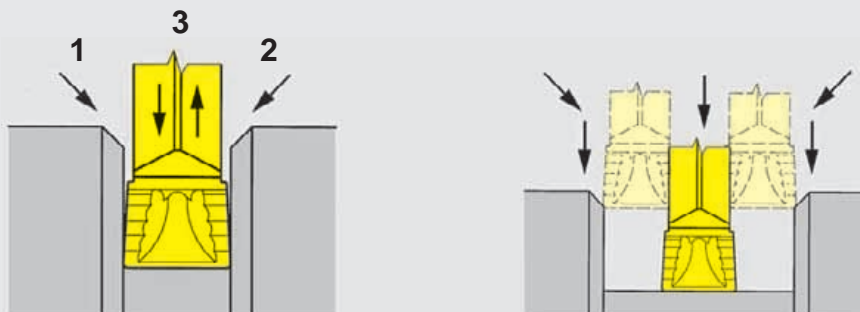

Nut entspricht Schneidbreite
 Width of groove and insert are equal

Nut breiter als Schneidplatte
 Groove wider than insert

Feinbearbeitung von Nuten

(Dichtnuten)

Finishing of Grooves

(Sealing Grooves)

Bedingt durch den Arbeitsablauf ergeben sich beim Schlichten von Nuten unterschiedliche Drehbilder (Stechen/Drehen). Dieser oft nur optische Unterschied ist nicht erwünscht.

Eine Lösung zeigt Abbildung 2 mit der modifizierten Schneidplatte S224...NC...D2.

This process requires both turning and grooving where very high quality surface finishes are required.

Diagram 2 shows the modified insert type S224...NC...D2.

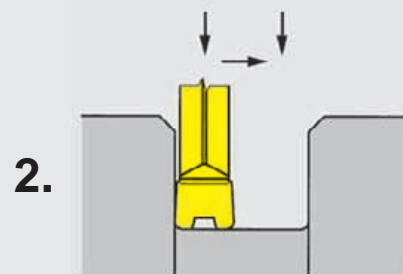
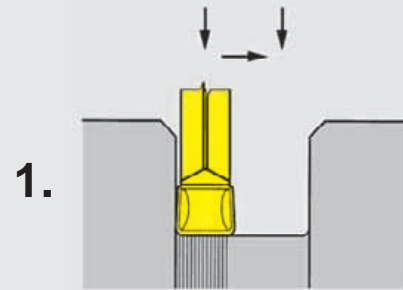

RINGBILDUNG

SWARF RING CREATION

Ringbildung wird vermieden, wenn keine überlappenden Drehoptionen vorkommen. Die Arbeitsabläufe sind so zu wählen, dass sich der Drehvorgang im überlappenden Bereich durch einen Stechvorgang abschließen lässt.

Je schärfer die Schneidplatte und je kleiner der Schneidenradius ist, desto geringer ist die Neigung zur Ringbildung.

Swarf ring creation can be avoided by turning across the smaller diameter in one continuous pass. Well defined cutting edges and small corner radii will reduce the tendency to create rings.

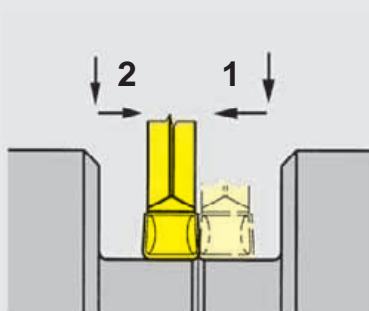

Ringbildung
Ring creation

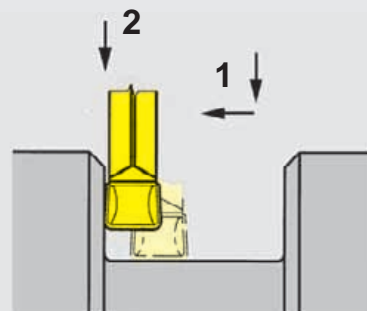

keine Ringbildung
No ring creation

Axialeinstechen Face Grooving

Wahl der Kassette

Verwenden Sie immer die Kassette, welche vom Bereich für den Außendurchmesser Ihrer Anwendung passt, um die größtmögliche Stabilität des Werkzeugs zu erhalten.

Cassette Selection

Select the cassette to suit the major diameter of the face groove to be cut.

Vemeiden von Vibrationen

Die Auskraglänge (x) des Klemmhalters sollte so gering wie möglich sein, um Vibrationen und Ablenkungen zu vermeiden.

Stable Setup

The tool should be set to give the minimum overhang to achieve maximum stability.

Arbeitsfolge

Das Auskammern breiterer Planeinstiche sollte stets vom Außendurchmesser nach innen erfolgen. Liegt der \emptyset -Bereich der Kassette am inneren \emptyset , kann nur von innen nach außen gefahren werden.

Working Practice

When turning to open up the face groove the cut should be taken from the major \emptyset towards the minor \emptyset .

Einrichten des Werkzeugs

Richten Sie das Werkzeug exakt auf Drehmitte aus, um ein Anlaufen bzw. Streifen der Kommaunterstützung zu vermeiden.

Tool Setup

The tool should be set to centre height to ensure correct cutting and support clearance.

Achten Sie auf parallele Stellung des Werkzeugs zur Drehachse.

The tool must be set parallel to the rotation axis of the workpiece.

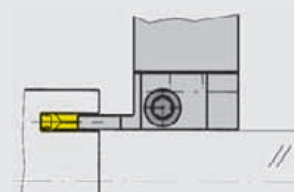
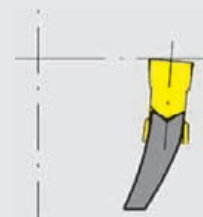
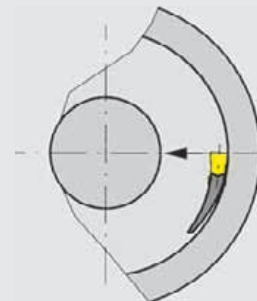
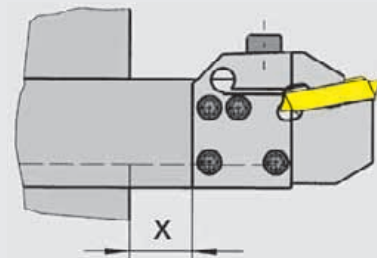

Form-Schneidplatten
Profiled Inserts

Profil-Beispiele
Examples of profiles

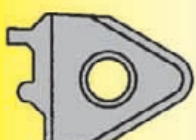
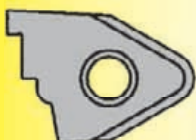
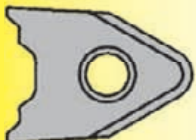
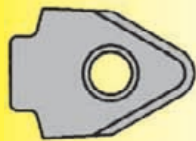
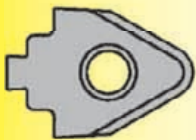
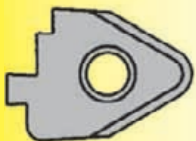
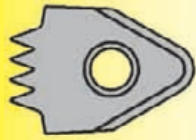

Die Formplatten werden nach Kunden-
vorgabe kurzfristig gefertigt.
Die Formplatten sind mit unterschiedlichen
Freiwinkeln lieferbar!
Besteht der Wunsch die Schneidplatten
nachzuschleifen, empfiehlt es sich, Formen
mit geringen Freiwinkeln zu verwenden.
Die Anzahl der möglichen Nachschliffe ist
von Freiflächenverschleiß und dem Zustand
der Schneide (Ausbrüche) abhängig.

Profiled inserts are manufactured according to
customer special requirements.
It is also possible to supply inserts with different relief
angles. If the customer wants to regrind or resharpen
the insert, we recommend to use small relief angles
around the cutting edge profile.
How many times the customer can regrind the insert,
depends on the condition of each individual insert.

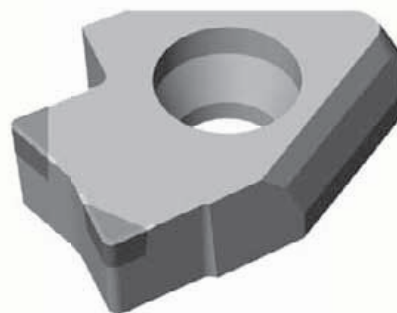

PKD- oder CBN-bestückte Schneidplatten
auf Anfrage lieferbar.
PCD- or PCBN-tipped inserts upon request.

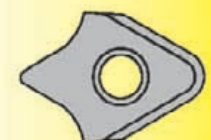
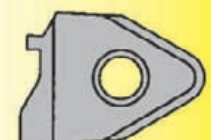
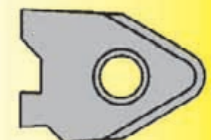
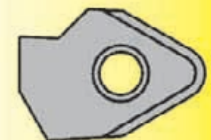
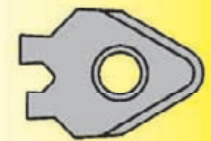
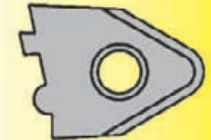
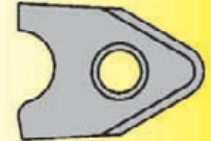
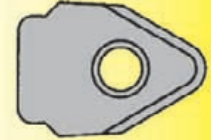

Metrisches ISO Regelgewinde (außen)
Metric ISO standard thread (external)

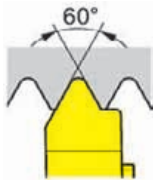

Gewindebezeichnung Thread	Teilprofil Partial profile	Vollprofil Full profile
M6 (M7)	R/L315.0610.01	R/L315.0610.02
M8 (M9)	R/L315.0712.01	R/L315.0712.02
M10 (M11)	R/L315.0915.01	R/L315.0915.02
M12	R/L315.1017.01	R/L315.1017.02
M14; M16	R/L315.1220.01	R/L315.1220.02
M18; M20; M22	R/L315.1525.01	R/L315.1525.02
M24; M27	R/L315.1830.01	R/L315.1525.02
M30; M33	R/L315.2135.01	R/L315.2135.02
M36	-	R/L315.2440.02
M24 - M68	R/L315.3060.01	-
M48; M52	-	R/L315.3050.02
M64; M68	-	R/L315.3660.02

Metrisches ISO Feingewinde (außen)
Metric ISO fine thread (external)

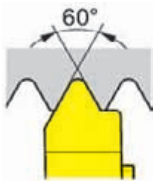

Gewindebezeichnung Thread	Teilprofil Partial profile	Vollprofil Full profile
M7,5x1	R/L315.0610.01	R/L315.0610.02
M10x1,25	R/L315.0712.01	R/L315.0712.02
M12x1,5	R/L315.0915.01	R/L315.0915.02
M17x2	R/L315.1220.01	R/L315.1220.02
M24x2,5	R/L315.1525.01	R/L315.1525.02
M30x3	R/L315.1830.01	R/L315.1525.02

Metrisches ISO Feingewinde (innen)
Metric ISO fine thread (internal)

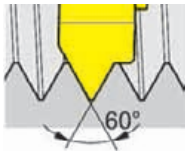

Gewindebezeichnung Thread	Teilprofil Partial profile	Vollprofil Full profile
M45x1	R/L315.0510.01	R/L315.0510.02
M45x1,5	R/L315.0815.01	R/L315.0815.02
M48x2	R/L315.1020.01	R/L315.1020.02
M48x2,5	R/L315.1325.01	R/L315.1325.02
M48x3	R/L315.1630.01	R/L315.1630.02
M48x3,5	R/L315.1835.01	R/L315.1835.02

Vollprofil, Whitworth (außen)
Full profile, Whitworth (external)

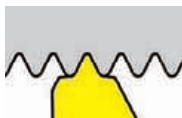

Gewindebezeichnung Thread	Vollprofil Full profile
G ^{1/16} / G ^{1/8}	R/L315.5528.02
G ^{1/4} / G ^{3/8}	R/L315.5519.02
G ^{1/2} / G ^{3/4}	R/L315.5514.02
G1 - G6	R/L315.5511.02

Metrisches ISO Trapezgewinde DIN103 (außen)
Metric ISO trapezoidal thread DIN103 (external)

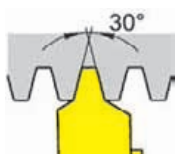

Gewindebezeichnung Thread	Vollprofil Full profile
Tr8x1,5	R/L315.1015.02
Tr9-10x2	R/L315.1320.02
Tr12-14x3	R/L315.1730.02
Tr16-20x4	R/L315.2240.02
Tr22-28x5	R/L315.2750.02
Tr30-36x6	R/L315.3560.02

Empfohlene Anzahl der Schnitte

Recommended number of passes

HM-Sorte / Carbide grade	Stahl (N/mm ² Festigkeit) Steel (N/mm ² Tensile strength)					rostfr. Stahl Stainless steel	Grauguss Grey cast iron	Aluminium Aluminium	
	400-500	500-700	700-850	850-1150	> 1150				
TN35	400-500	500-700	700-850	850-1150	> 1150	90	100	300	
V _{max} m/min	160	140	120	90	70	90	100	300	
Steigung / Pitch		Anzahl der Schnitte / Number of passes							
mm	Gg/" tpi								
0,8	32	8	8	9	9	10	10	9	8
1,0	24	10	10	12	12	12	12	12	10
1,25	20-19	12	12	14	14	15	15	14	12
1,5	16	15	15	17	17	18	18	17	15
1,75	14	17	17	19	19	21	21	18	17
2,0	12-11	19	20	22	22	25	25	20	18
2,5	10	22	24	26	26	31	31	22	20
3,0-3,5	8	28	30	32	32	38	38	24	22

Vorschubsrichtung Innengewindedrehen

Feed direction internal threading

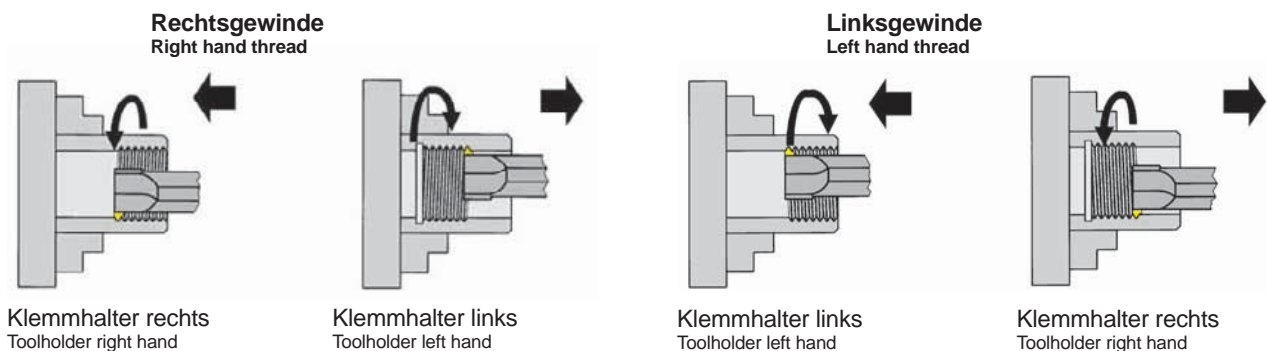

Zustellung

In-Feed

Radiale Zustellung

Radial In-Feed

Die gebräuchlichste Methode Gewinde herzustellen. Beide Schneiden sind gleichzeitig im Eingriff.

Metal removed on both sides of the insert simultaneously. The most commonly used method for thread production.



Modifizierte Flankenzustellung

Modified flank in-feed

Weniger Verschleiß der Schleppschiene und eine bessere Oberflächengüte der entsprechenden Gewindeflanke.

Less wear of the trailing edge and better surface finish on corresponding flank.



Wechselnde Flankenzustellung

Alternating flank in-feed

Beide Schneidflanken werden gleichmäßig benutzt, ergibt höhere Standzeiten.

Both edges are being fully utilised which means longer insert life.



Einseitige Flankenzustellung

Flank in-feed

Geringerer Schnittdruck und bessere Wärmeabfuhr.

More easily formed chip and better heat dissipation.



Abstechen

Parting Off

Wendeschneidplatten mit gerader Schneide

Wendeschneidplatten mit gerader Schneide sind, sofern möglich, auch beim Abstechen zu bevorzugen.

- Vorteile:
- höchste Standmengen
 - bester Spanfluss und damit gute Oberflächen
 - hohe Schnittwerte möglich

Indexable inserts with square cutting edge

The best selection for applications are inserts with a square cutting edge, wherever possible to use them.

- Advantages:
- increased tool life
 - better swarf control and a high surface quality will be obtained
 - possibility to choose the maximum cutting data

Vorschubgröße

Bei Verwendung von Abstechtschrägen kann sich der empfohlene Vorschub, der sich stets auf eine gerade Schneide bezieht, je nach Größe der Schräge bis auf 40 % reduzieren. Starker Einfluss hat hierbei die Dehnung des zu bearbeitenden Werkstoffes.

Feed rates

The feed rate when cutting with front cutting angle will need to be reduced up to 40 %. This may also be influenced by the tensile strength of the material to be cut.

Spänestau

Durch die Wahl der geeigneten Schnittgeschwindigkeit und des richtigen Vorschubs, werden Spänestau und durch Späne verletzte Oberflächen vermieden.

Swarf control

Best swarf control and highest surface finish will be obtained by choosing the right speed and feed rate.

Butzen- oder Gratbildung

Verringerung des Butzens oder des Grats wird durch exakte Einstellung auf Spitzenhöhe und durch Verwendung von R/L Schneidplatten (mit Abstechtschräge) erreicht. Gleichzeitig gewährleistet die korrekte Einstellung beste Spanformung und Spankontrolle.

Avoiding Pips

By using right or left handed inserts and the correct centre height occurring of pips and burrs can be reduced.

Abgreifen

Abgreifspindeln oder -vorrichtungen verhindern eine Beschädigung der Schneide durch Abfallen schlagender Teile.

Beim »fliegenden« Abstechen empfiehlt es sich, den Vorschub vor dem Abstechen oder Durchtrennen deutlich zu reduzieren.

Parting off with a sub spindle or part catcher

The cutting edge will be protected by having a second spindle or fixture to pick up the workpiece. Parting off without a support requires the feed rate to be reduced as the tool approaches centre.

Balligkeit der Oberfläche

Ballige Abstiche bei Verwendung von Schneidplatten mit Abstechtschräge werden durch Verringerung des Vorschubs vermindert.

Convex or concave surfaces

Convex or concave surfaces will be avoided when using right or left hand inserts by reducing the feed rate.

Kühlschmiermittel

Kühlschmiermittel ist in ausreichender Menge und platziert zuzuführen.

Coolant

A copious well aimed coolant supply will give long tool life.

Varianten der Anschlüsse für innere Kühlmittelzufuhr.
Different methods of coolant supply.



Externer Anschluss, z.B. von mobilen Hochdruckstationen über den Werkzeughalter.

External connection e.g. through high pressure pump to the toolholder.

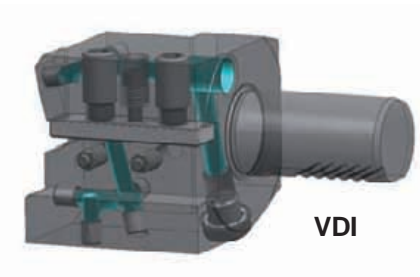

Interner Anschluss über den Werkzeugrevolver durch den Werkzeughalter.

Internal connection through turret to the toolholder.

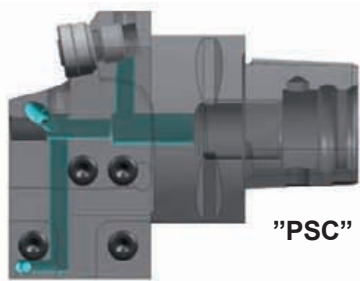

Interner Anschluss durch den Grundhalter und über eine entsprechende Kasette.

Internal connection through toolholder back-end to the cassette.

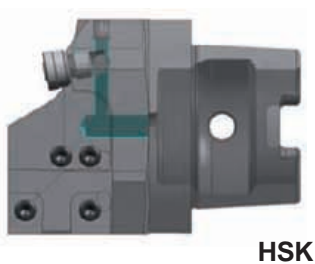
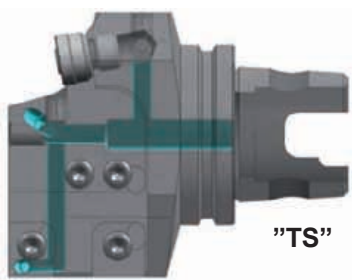

Möglichkeiten des Kühlmittelaustritts.
Coolant supply options.

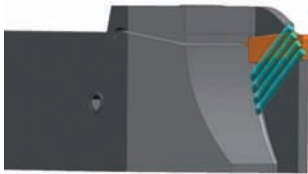

Austritt über Fächerdüsen seitlich
der Schneidplatte.

Coolant outlet through spray nozzle at the side of the insert.

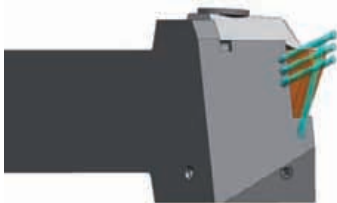

Austritt über Fächerdüsen seitlich
der Schneidplatte.

Coolant outlet through spray nozzle at the side of the insert.



S100
S224
S229

Austritt über Spannfinger.

Coolant outlet through clamping finger.

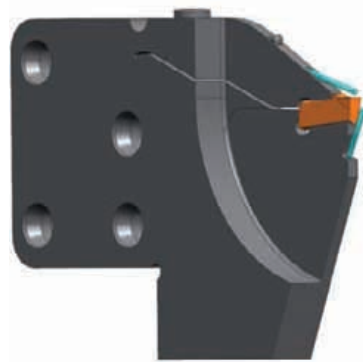

S100
S224
S229

Austritt des Kühlmittels in Kombination von Spannfinger
und Unterstützung.

Coolant outlet through clamping finger and insert support.

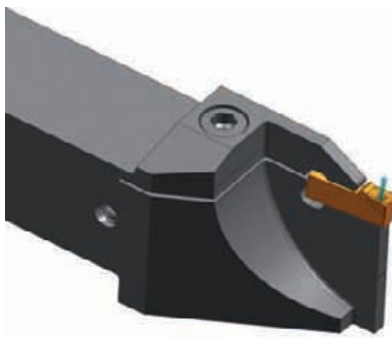

S100
S224

Austritt des KSS durch die Schneidplatte.

Coolant outlet through insert.

U

Verstärkte Schwerter - Einbausituation

Reinforced Blades - Positioning

Einbaulage
 "Überkopf"
 Position
 "upside down"

Gegenspindel
 Subspindle

Hauptspindel
 Mainspindle

M4 Linkslauf
 M4 Anticlockwise

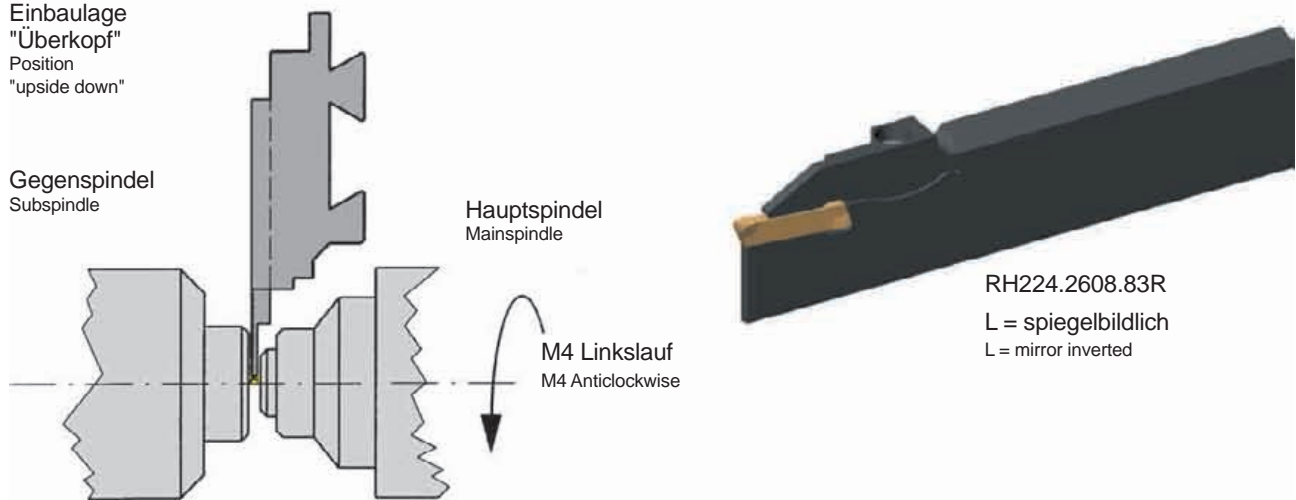

RH224.2608.83R

L = spiegelbildlich
 L = mirror inverted

U

Einbaulage
 "normal"
 Position
 "normal"

Gegenspindel
 Spannzange
 Subspindle
 Collet

Hauptspindel
 Mainspindle

M3 Rechtslauf
 M3 Clockwise

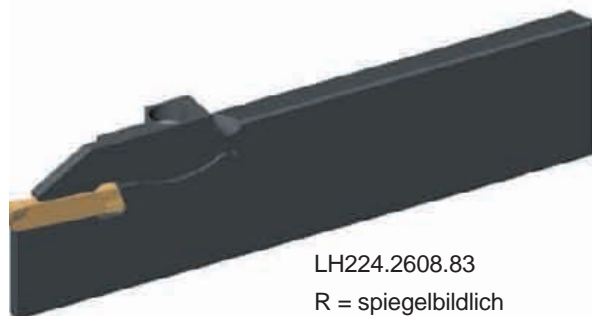

LH224.2608.83

R = spiegelbildlich
 R = mirror inverted

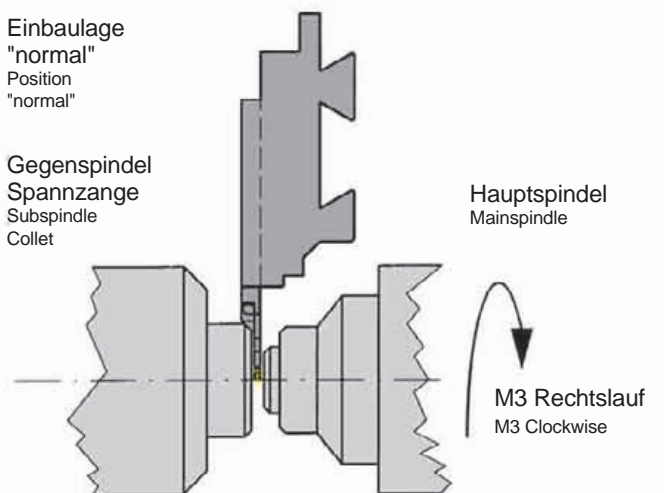

Einbaulage
 "normal"
 Position
 "normal"

Gegenspindel
 Spannzange
 Subspindle
 Collet

Hauptspindel
 Mainspindle

M3 Rechtslauf
 M3 Clockwise

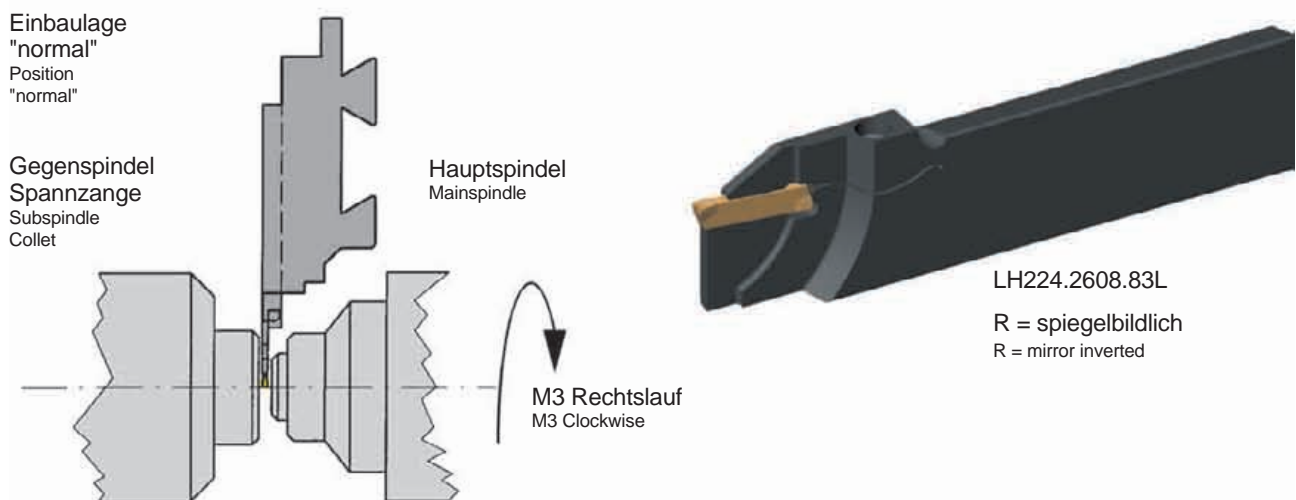

LH224.2608.83L

R = spiegelbildlich
 R = mirror inverted

Diese angepasste Bauform kann bei allen verstärkten Schwertern hergestellt werden.
 These special reinforced form can be produced on all blades.

Geometrien und Vorschübe Typ S119 / S223

Geometries and feed rates type S119 / S223



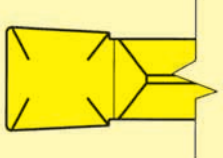
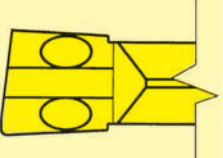
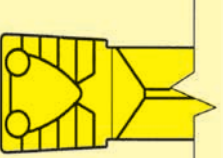

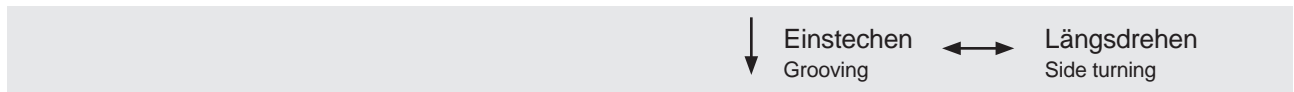
Geometrie Geometry	Einsatzgebiete Applications	Vorschub f (mm/U) Feed rate f (mm/rev)
.3. 	Einstecken, Nuten schlichten, Geometrie für Form-WSP, kurzspanende und hochfeste Werkstoffe grooving, finishing of grooves, geometry for inserts with profile, for short chipping materials and high tensile strength	↓ 0,03 - 0,15 ↔ 0,05 - 0,20 a_{pmax} 1,5
.C. 	Abstechen, für langspanende Werkstoffe parting off, for long chipping materials	↓ 0,02 - 0,12
.5. 	Einstecken, Längsdrehen, Kopieren von Formnuten, ausgezeichnete Spanverjüngung bei Werkstoffen mittlerer Festigkeit grooving, side turning, profiling of grooves, excellent reduction of chip width in materials with medium tensile strength	↓ 0,08 - 0,20 ↔ 0,15 - 0,20 a_{pmax} 1,5



Geometrien und Vorschübe Typ S209 / 216

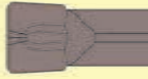
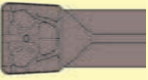

Geometries and feed rates type S209 / 216



Geometrie Geometry	Einsatzgebiete Applications	Vorschub f (mm/U) Feed rate f (mm/rev)
.1A. 	Einstecken, Nuten schlichten, für langspanende Werkstoffe, "geringe Vorschübe" grooving, finishing of grooves, for long chipping materials, low feed rates	↓ 0,03 - 0,12
.5. 	Einstecken, Längsdrehen, Kopieren von Formnuten, ausgezeichnete Spanverjüngung bei Werkstoffen mittlerer Festigkeit grooving, side turning, profiling of grooves, excellent reduction of chip width in materials with medium tensile strength	↓ ↔ 0,06 - 0,20 0,05 - 0,20
.KF 	Einstecken, Längsdrehen, Kopieren von Formnuten, ausgezeichnete Spanverjüngung bei Werkstoffen mittlerer Festigkeit grooving, side turning, profiling of grooves, excellent reduction of chip width in materials with medium tensile strength	↓ ↔ 0,03 - 0,15 0,05 - 0,15

↓ Einstechen Grooving ↔ Längsdrehen Side turning

U



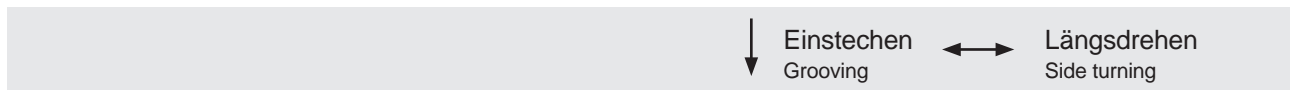

Geometrie Geometry	Einsatzgebiete Applications	Vorschub f (mm/U) Feed rate f (mm/rev)
<p>.00</p> 	<p>Einstecken, Nuten schlichten, für langspanende Werkstoffe, "geringe Vorschübe"</p> <p>grooving, finishing of grooves, for long chipping materials, low feed rates</p>	<p>↓ 0,02 - 0,12</p>
<p>Spanleitstufe für Sonder-WSP Chipbreaker for special inserts</p> 	<p>Einstecken, Nuten schlichten, Geometrie für Form-WSP, kurzspanende und hochfeste Werkstoffe</p> <p>grooving, finishing of grooves, geometry for inserts with profile, for short chipping materials and high tensile strength</p>	<p>↓ 0,02 - 0,12</p>

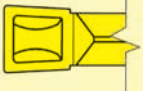
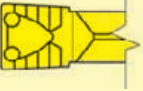
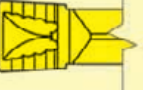

Geometrien und Vorschübe Typ 224 / S224

Geometries and feed rates type 224 / S224

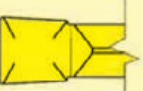
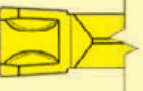
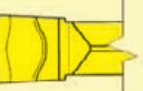

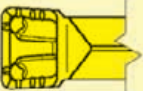
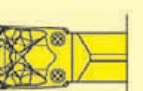
Geometrie Geometry	Einsatzgebiete Applications	Vorschub f (mm/U) Feed rate f (mm/rev)
.3. 	Einstecken, Längsdrehen, Kopieren von Formnuten, geeignet für Werkstoffe mit höherer Festigkeit grooving, side turning, profiling of grooves, suitable for materials with high tensile strength	↓ 0,15 - 0,25 ↔ 0,15 - 0,40*
.5. 	Einstecken, Längsdrehen, Kopieren von Formnuten, ausgezeichnete Spanverjüngung bei Werkstoffen mittlerer Festigkeit grooving, side turning, profiling of grooves, excellent reduction of chip width in materials with medium tensile strength	↓ 0,10 - 0,45 ↔ 0,15 - 0,60*
.A. 	Einstecken, Längsdrehen, Schlichten bzw. Kopieren von Formnuten, ausgezeichneter Spanbruch bei Werkstoffen mittlerer Festigkeit grooving, side turning, finishing or profiling of grooves, excellent chip breaking in materials with medium tensile strength	↓ 0,05 - 0,30 ↔ 0,10 - 0,30*
.C. 	Abstechen, für langspanende Werkstoffe parting off, for long chipping materials	↓ 0,02 - 0,10
.D. 	Einstecken, Nuten schlichten, für langspanende Werkstoffe, "geringe Vorschübe" grooving, finishing of grooves, for long chipping materials, low feed rates	↓ 0,03 - 0,15 ↔ 0,05 - 0,20
.E./EN. 	Einstecken, Längsdrehen, Kopieren von Formnuten, geeignet für Werkstoffe mit höherer Festigkeit grooving, side turning, profiling of grooves, suitable for materials with high tensile strength	↓ 0,08 - 0,30
.F./FY 	Einstecken, Nuten schlichten, für langspanende Werkstoffe, "geringe Vorschübe" grooving, finishing of grooves, for long chipping materials, low feed rates	↓ 0,03 - 0,15
.H. 	Einstecken im "Karo-Stechverfahren", Kopieren im Teilschnitt von langspanenden Werkstoffen grooving in "pecking process", profiling in partial cut, for long chipping	↓ 0,15 - 0,25 ↔ 0,10 - 0,25
.K./KF 	Einstecken, Längsdrehen, Schlichten bzw. Kopieren von Formnuten, grooving, side turning, finishing or profiling of grooves	↓ 0,05 - 0,25 ↔ 0,05 - 0,25
.L. 	Einstecken im Voll- und Teilschnitt bei guter Spankontrolle grooving in full and partial cut with excellent chip control	↓ 0,10 - 0,22 ↔ 0,05 - 0,20
.ZG. 	Einstecken, Längsdrehen, Kopieren von Formnuten grooving, side turning, profiling of grooves	↓ 0,10 - 0,22 ↔ 0,05 - 0,20

* abhängig von Schneidbreite, Eckenradius und Material
* dependent upon insert width, edge radii and material







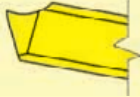

↓ Einstecken
Grooving

↔ Längsdrehen
Side turning

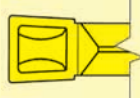
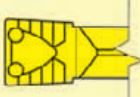
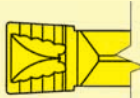
Geometrien und Vorschübe Typ 229/S229

Geometries and feed rates type 229/S229

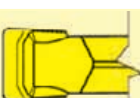
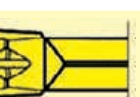

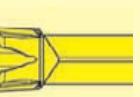
Geometrie Geometry	Einsatzgebiete Applications	Vorschub f (mm/U) Feed rate f (mm/rev)
.10 	Einstecken, Nuten schlichten, für langspanende Werkstoffe, "geringe Vorschübe" grooving, finishing of grooves, for long chipping materials, low feed rates	↓ 0,05 - 0,15
.20 	Einstecken, Nuten schlichten, Geometrie für Form-WSP, kurzspanende und hochfeste Werkstoffe grooving, finishing of grooves, geometry for inserts with profile, for short chipping materials and high tensile strength	↓ 0,07 - 0,25
.3. 	Einstecken, Längsdrehen, Kopieren von Formnuten, geeignet für Werkstoffe mit höherer Festigkeit grooving, side turning, profiling of grooves, suitable for materials with high tensile strength	↓ 0,15 - 0,25 ↔ 0,15 - 0,40*
.5. 	Einstecken, Längsdrehen, Kopieren von Formnuten, ausgezeichnete Spanverjüngung bei Werkstoffen mittlerer Festigkeit grooving, side turning, profiling of grooves, excellent reduction of chip width in materials with medium tensile strength	↓ 0,10 - 0,45 ↔ 0,15 - 0,60*
.A. 	Einstecken, Längsdrehen, Schlichten bzw. Kopieren von Formnuten, ausgezeichneter Spanbruch bei Werkstoffen mittlerer Festigkeit grooving, side turning, finishing or profiling of grooves, excellent chip breaking in materials with medium tensile strength	↓ 0,05 - 0,30 ↔ 0,10 - 0,30*
.C. 	Abstechen, für langspanende Werkstoffe parting off, for long chipping materials	↓ 0,02 - 0,10
.E./EN 	Einstecken, Längsdrehen, Kopieren von Formnuten, geeignet für Werkstoffe mit höherer Festigkeit grooving, side turning, profiling of grooves, suitable for materials with high tensile strength	↓ 0,08 - 0,30
.F./FY 	Einstecken, Nuten schlichten, für langspanende Werkstoffe, "geringe Vorschübe" grooving, finishing of grooves, for long chipping materials, low feed rates	↓ 0,03 - 0,15
.H. 	Einstecken im "Karo-Stechverfahren", Kopieren im Teilschnitt von langspanenden Werkstoffen grooving in "pecking process", profiling in partial cut, for long chipping	↓ 0,15 - 0,25 ↔ 0,10 - 0,25
.HR. 	Einstecken im Voll- und Teilschnitt bei guter Spankontrolle grooving in full and partial cut with excellent chip control	↓ 0,20 - 0,30
.L. 	Einstecken im Voll- und Teilschnitt bei guter Spankontrolle grooving in full and partial cut with excellent chip control	↓ 0,10 - 0,22 ↔ 0,05 - 0,20
.K./KF 	Einstecken, Längsdrehen, Schlichten bzw. Kopieren von Formnuten, grooving, side turning, finishing or profiling of grooves	↓ 0,05 - 0,25 ↔ 0,05 - 0,25
.N. 	Einstecken, Längsdrehen, Schlichten bzw. Kopieren von Formnuten, ausgezeichneter Spanbruch bei Werkstoffen mittlerer Festigkeit grooving, side turning, finishing or profiling of grooves, excellent chip breaking in materials with medium tensile strength	↓ 0,05 - 0,25 ↔ 0,05 - 0,20

* abhängig von Schneidbreite, Eckenradius und Material
* dependent upon insert width, edge radii and material

↓ Einstecken Grooving ↔ Längsdrehen Side turning

U

Geometrien und Vorschübe Typ 231



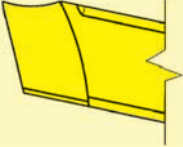
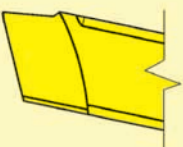
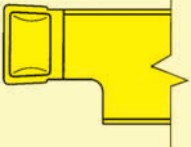

Geometries and feed rates type 231

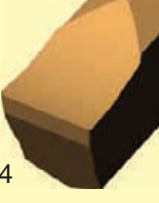

Geometrie Geometry	Einsatzgebiete Applications	Vorschub f (mm/U) Feed rate f (mm/rev)
<p>.10</p> 	<p>Einstecken, Nuten schlichten, für langspanende Werkstoffe, "geringe Vorschübe"</p> <p>grooving, finishing of grooves, for long chipping materials, low feed rates</p>	<p>↓ 0,02 - 0,12</p>
<p>.20</p> 	<p>Einstecken, Nuten schlichten, Geometrie für Form-WSP, kurzspanende und hochfeste Werkstoffe</p> <p>grooving, finishing of grooves, geometry for inserts with profile, for short chipping materials and high tensile strength</p>	<p>↓ 0,02 - 0,12</p>
<p>.3.</p> 	<p>Einstecken, Längsdrehen, Kopieren von Formnuten, Geometrie für Form-WSP, geeignet für Werkstoffe mit höherer Festigkeit</p> <p>grooving, side turning, profiling and finishing of grooves, for long chipping materials with high tensile strength</p>	<p>↓ 0,15 - 0,25</p> <p>↔ 0,15 - 0,40*</p>

* abhängig von Schneidbreite, Eckenradius und Material
* dependent upon insert width, edge radii and material

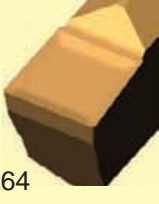
↓ Einstecken Grooving ↔ Längsdrehen Side turning

Geometrie Geometry	Einsatzgebiete Applications	Vorschub f (mm/U) Feed rate f (mm/rev)
.10  264	Einstecken und Abstechen Grooving and parting off	↓ 0,02 - 0,08
.20  264	Einstecken und Abstechen für hochfeste Werkstoffe Grooving and parting off for materials high tensile strength	↓ 0,02 - 0,08
.D1  S264	Einstecken und Längsdrehen Grooving and turning	↓ 0,03 - 0,13 ↔ 0,05 - 0,20 $a_{pmax} = 1,5 \times w$
.M0  264	Einstecken, Längsdrehen und Abstechen für Messing (Ms58) Grooving, turning and parting off for Brass (Ms58)	↓ 0,02 - 0,10 ↔ 0,02 - 0,15
.P.  264	Einstecken und Abstechen Grooving and parting off	↓ 0,02 - 0,08 ↔ 0,02 - 0,04 $a_{pmax} = 1,5 \times w$

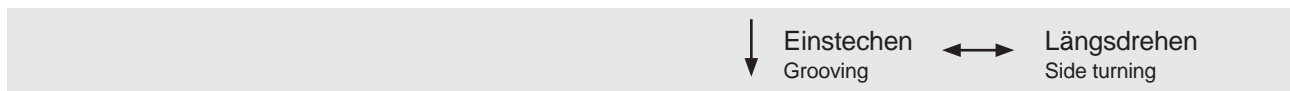



U

Geometrien und Vorschübe Typ S274

Geometries and feed rates type S274



Geometrie Geometry	Einsatzgebiete Applications	Vorschub f (mm/U) Feed rate f (mm/rev)
.10 	Einstecken, Nuten schlichten, für langspanende Werkstoffe, "geringe Vorschübe" grooving, finishing of grooves, for long chipping materials, low feed rates	↓ 0,02 - 0,12
.M. 	Einstecken, Nuten schlichten, Geometrie für Form-WSP, kurzspanende und hochfeste Werkstoffe grooving, finishing of grooves, geometry for inserts with profile, for short chipping materials and high tensile strength	↓ 0,02 - 0,12
.P. 	Einstecken und Längsdrehen (in eine Richtung) Grooving and turning (in one direction)	↓ 0,02 - 0,10 ↔ 0,02 - 0,10

↓ Einstecken Grooving ↔ Längsdrehen Side turning

Geometrien und Vorschübe Typ 34T

Geometries and feed rates type 34T

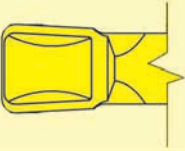
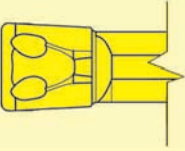
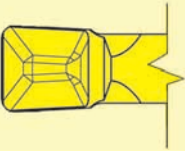

Geometrie Geometry	Einsatzgebiete Applications	Vorschub f (mm/U) Feed rate f (mm/rev)
.3. 	Einstecken, Längsdrehen, Kopieren von Formnuten, Geometrie für Form-WSP, geeignet für Werkstoffe mit höherer Festigkeit grooving, side turning, profiling and finishing of grooves, for long chipping materials with high tensile strength	↓ 0,15 - 0,25 ↔ 0,15 - 0,40*
.5. 	Einstecken, Längsdrehen, Kopieren von Formnuten, ausgezeichnete Spanverjüngung bei Werkstoffen mittlerer Festigkeit grooving, side turning, profiling of grooves, excellent reduction of chip width in materials with medium tensile strength	↓ 0,08 - 0,25 ↔ 0,10 - 0,20*
.D. 	Einstecken, Kopieren von Formnuten, geeignet für Werkstoffe mit höherer Festigkeit grooving, profiling of grooves, suitable for materials with high tensile strength	↓ 0,03 - 0,15 ↔ 0,05 - 0,20







* abhängig von Schneidbreite, Eckenradius und Material
* dependent upon insert width, edge radii and material

↓ Einstecken Grooving ↔ Längsdrehen Side turning

Geometrien und Vorschübe Typ 312 / S312

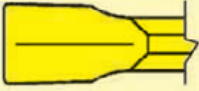
Geometries and feed rates type 312 / S312

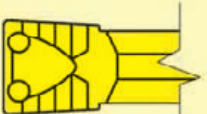

Geometrie Geometry	Einsatzgebiete Applications	Vorschub f (mm/U) Feed rate f (mm/rev)
.00  312	Einstecken, Nuten schlichten, für langspanende Werkstoffe, "geringe Vorschübe" grooving, finishing of grooves, for long chipping materials, low feed rates	↓ 0,02 - 0,12
Spanleitstufe für Sonder-WSP Chipbreaker for special inserts  312	Einstecken, Nuten schlichten, Geometrie für Form-WSP, kurzspanende und hochfeste Werkstoffe grooving, finishing of grooves, geometry for inserts with profile, for short chipping materials and high tensile strength	↓ 0,02 - 0,12
.V.  312	Einstecken, bei guter Spankontrolle grooving, with excellent chip control	↓ 0,04 - 0,15
.F.  S312	Einstecken, Kopieren von Nuten, leichter Schnitt grooving, profiling of grooves, easy cut	↓ 0,03 - 0,15
.5.  S312	Einstecken, Längsdrehen, Kopieren von Formnuten, ausgezeichnete Spanverjüngung bei Werkstoffen mittlerer Festigkeit grooving, side turning, profiling of grooves, excellent reduction of chip width in materials with medium tensile strength	↓ 0,08 - 0,25 ↔ 0,10 - 0,20*
.D.  S312	Einstecken, Kopieren von Formnuten, geeignet für Werkstoffe mit höherer Festigkeit grooving, profiling of grooves, suitable for materials with high tensile strength	↓ 0,03 - 0,15 ↔ 0,05 - 0,20
.C.  S312	Abstechen, Einstecken parting off, grooving	↓ 0,02 - 0,10







* abhängig von Schneidbreite, Eckenradius und Material
* dependent upon insert width, edge radii and material

↓ Einstecken Grooving ↔ Längsdrehen Side turning

Geometrien und Vorschübe Typ 315 / S315

Geometries and feed rates type 315 / Sf15



Geometrie Geometry	Einsatzgebiete Applications	Vorschub f (mm/U) Feed rate f (mm/rev)
.00  315	Einstecken, Nuten schlichten, für langspanende Werkstoffe, "geringe Vorschübe" grooving, finishing of grooves, for long chipping materials, low feed rates	↓ 0,02 - 0,12
Spanleitstufe für Sonder-WSP Chipbreaker for special inserts  315	Einstecken, Nuten schlichten, Geometrie für Form-WSP, kurzspanende und hochfeste Werkstoffe grooving, finishing of grooves, geometry for inserts with profile, for short chipping materials and high tensile strength	↓ 0,02 - 0,12
.EN.  S315	Einstecken, Längsdrehen, Kopieren von Formnuten, geeignet für Werkstoffe mit höherer Festigkeit grooving, side turning, profiling of grooves, suitable for materials with high tensile strength	↓ 0,08 - 0,15
.FL.  S315	Einstecken, Nuten schlichten, für langspanende Werkstoffe, "niedrige Vorschübe" bei guter Spanformung grooving, finishing of grooves, for long chipping materials, "low feed rates" with excellent chip control	↓ 0,03 - 0,15
.FY.  S315	Einstecken, Nuten schlichten, für langspanende Werkstoffe, "niedrige Vorschübe" bei guter Spanformung grooving, finishing of grooves, for long chipping materials, "low feed rates" with excellent chip control	↓ ↔ 0,03 - 0,15
.L.  S315	Einstecken im Voll- und Teilschnitt bei guter Spankontrolle grooving in full and partial cut with excellent chip control	↓ ↔ 0,10 - 0,15 ↔ 0,05 - 0,10



↓ Einstecken Grooving ↔ Längsdrehen Side turning

U

Geometrien und Vorschübe Typ S316

Geometries and feed rates type S316

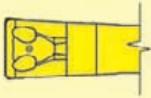



Geometrie Geometry	Einsatzgebiete Applications	Vorschub f (mm/U) Feed rate f (mm/rev)
.5. 	Einstecken, Längsdrehen, Kopieren von Formnuten, ausgezeichnete Spanverjüngung bei Werkstoffen mittlerer Festigkeit grooving, side turning, profiling of grooves, excellent reduction of chip width in materials with medium tensile strength	↓ 0,06 - 0,25
.EN. 	Einstecken, Längsdrehen, Kopieren von Formnuten, geeignet für Werkstoffe mit höherer Festigkeit grooving, side turning, profiling of grooves, suitable for materials with high tensile strength	↓ 0,08 - 0,20
.FY. 	Einstecken, Nuten schlichten, für langspanende Werkstoffe, "niedrige Vorschübe" bei guter Spanformung grooving, finishing of grooves, for long chipping materials, "low feed rates" with excellent chip control	↓ 0,03 - 0,15

↓ Einstecken Grooving ↔ Längsdrehen Side turning

Geometrien und Vorschübe Typ 64T

Geometries and feed rates type 64T



Geometrie Geometry	Einsatzgebiete Applications	Vorschub f (mm/U) Feed rate f (mm/rev)
.1A 	Einstechen, Nuten schlichten, für langspanende Werkstoffe, "geringe Vorschübe" grooving, finishing of grooves, for long chipping materials, low feed rates	↓ 0,03 - 0,12
.DL 	Einstechen, Längsdrehen, Schlichten bzw. Kopieren von Formnuten grooving, side turning, finishing or profiling of grooves	↓ 0,05 - 0,15 ↔ 0,05 - 0,20

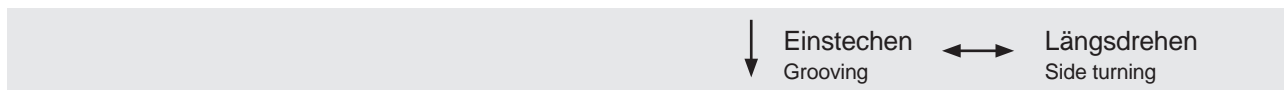

U

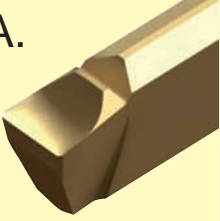
Geometrie Geometry	Einsatzgebiete Applications	Vorschub f (mm/U) Feed rate f (mm/rev)
.WA. 	Einstecken und Abstecken, Nuten schlichten, leichter Schnitt Grooving and parting off, finishing of grooves, easy cut	↓ 0,07 - 0,25

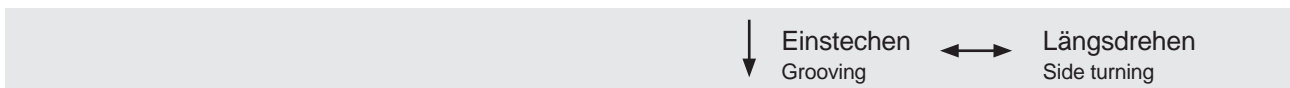

Schnittdaten

Cutting data

Werkstoff Material	Härte Hardness Brinell (HB)	Schnittgeschwindigkeit v_c (m/min) Cutting speed v_c (m/min)		
		K10	DD26	
N Al-Legierungen Al-alloys	nicht vergütbar not heat treatable	30-80	1000-600	1000-600
	vergütbar heat treatable	80-120	400-220	400-220
Al-Guss-Legierung Al-cast-alloy	nicht vergütbar not heat treatable	80	1000-600	1000-600
	vergütbar heat treatable	100	600-300	600-300

Geometrien und Vorschübe Abstechen

Geometries and feed rates Parting off



Geometrie Geometry	Einsatzgebiete Applications	Vorschub f (mm/U) Feed rate f (mm/rev)	Lieferbare Geometrien und Abstechschrägen Available geometries and lead angle									
			S100	S123/S223	S274	S264	S224	229/S229	312/S312	S315	S316	
.00	Abstechen Parting off	0,02 - 0,10								0°		
		0,02 - 0,08								5°		
.00	Abstechen dünnwandiger Teile Tubes with small thickness	0,02 - 0,06				8°				8°		
		0,02 - 0,05			15°	15°				12°		
.00	Abstechen mit Spanformrille Parting off with chip former	0,02 - 0,15								0°		
		0,02 - 0,15								5°		
.M.	Abstechen spröder Materialien (MS58) Parting off brittle materials (MS58)	0,02 - 0,15								0°	0°	
		0,02 - 0,15								5°		
		0,02 - 0,12				8°						
		0,02 - 0,10				15°						
.V.	Abstechen mit Spanformung Parting off with chip forming	0,02 - 0,12								0°		
		0,02 - 0,08								5°		
.3V.	Abstechen Parting off	0,05 - 0,2	0°									
.C.	Abstechen Parting off	0,02 - 0,10		0°			0°	0°	0°			
		0,02 - 0,08		4°			5°	5°	5°			
		0,02 - 0,06		8°			8°	8°	8°			
		0,02 - 0,05		15°			15°					
.E.	Abstechen Parting off	0,02 - 0,12	0°				0°	0°				
		0,05 - 0,12	5°				5°					
.EN	Abstechen Parting off	0,10 - 0,25	0°				0°	0°			0°	
		0,10 - 0,20	5°									
*.D. (.32)	Abstechen Parting off	0,02 - 0,10		0°			0°		0°			
.F.	Abstechen Parting off	0,02 - 0,12	0°				0°	0°				
		0,02 - 0,10	5°				5°					
.3.	Abstechen Parting off	0,10 - 0,15					0°	0°				
		0,08 - 0,12						5°				
.N.	Abstechen Parting off	0,05 - 0,2	0°					0°				

* nur Schneidplatten S123 / S223

* only Inserts S123 / S223

U

Schnittdaten Ein- und Abstechen

Cutting data Grooving and parting off



Werkstoff Material	Härte Hardness Brinell (HB)	Schnittgeschwindigkeit v_c (m/min) Cutting speed v_c (m/min)												
		K10	MG12	P20	TI22 TN32	TI25 TN35	TA45 TH35	TA46	AS62	AL96 AS66	H20	H54		
P Kohlenstoffstahl Carbon steel	0,2% C	140			180-120	200-160	180-130	200-160	280-180	250-180	300-180	230-170	200-140	
	0,4% C	180			160-110	180-150	170-120	180-150	250-140	230-170	270-150	220-160	180-120	
	0,6% C	200			140-90	180-140	150-100		230-120	220-160	250-120	210-150	160-100	
	Legierter Stahl Alloyed steel (<5%)	geglüht annealed	180			140-100	180-140	160-110	180-140	230-100	200-150	250-100	210-150	180-120
		vergütet quenched	280			110-90	160-110	130-90		190-90	160-110	220-90	170-120	160-100
		vergütet quenched	350			80	140-90	100-70		170-80	130-100	200-80	140-80	120-80
	hochlegierter Stahl high alloyed steel (>5%)	geglüht annealed	200			120-80	120-90			200-140	180-120	220-140	120-100	100-90
		gehärtet hardened	-											
	Stahlguss Cast steel	unlegiert unalloyed	180				130-100				200-150	200-150	180-120	
		legiert alloyed	220				110-80				160-100	150-90	140-90	
M Rostfreier Stahl Stainless steel	martensitisch ferritisch martensitic, ferritic	200		90-70		130-100	120-60		180-120	170-120	190-140	190-120		
	austenitisch austenitic	180		90-60			100-70		140-110		140-110	170-120		
K Grauguss Grey cast iron	niedrige Festigkeit low tensile strength	180	90-60	80-60				130-90	180-120	180-120	200-120			
	hohe Festigkeit high tensile strength	250	90-60	80-60				90-70	140-100	140-100	160-120			
	Kugelgraphit- guss Spheroidal graphite cast iron	ferritisch ferritic	160				90-70	90-70	120-80	170-90	170-90	180-130		
		perlitisch perlitic	250				70-60	70-60	110-80	180-80	150-80	160-120		
	Temperguss Malleable cast iron	ferritisch ferritic	125		100-80		140-120	100-70		120-100	190-140	220-120		
		perlitisch perlitic	225		70-50		100-80	80-60		90-80	140-100	190-100		
N Al-Legierungen Al-alloys	nicht vergütbar not heat treatable	30-80	1000-600	800-400			1000-600							
	vergütbar heat treatable	80-120	400-220	300-200			400-220							
	Al-Guss-Legie- rung Al-cast-alloy	nicht vergütbar not heat treatable	80	1000-600	800-400			1000-600						
		vergütbar heat treatable	100	600-300	400-250			600-300						
	Kupfer-Legie- rungen Copper-alloys	nicht vergütbar not heat treatable	90	200-120			200-150	210-130		200-150				
		vergütbar heat treatable	100	150-90			150-60	160-90		150-110				
S Warmfeste Legierung Heat resistant alloy (Fe)	geglüht annealed	200		50-30			50-30							
	gehärtet hardened	275		40-20			40-20							
	Warmfeste Legierung Heat resistant alloy (Ni, Co)	geglüht annealed	250		30-20			30-20						
		gehärtet hardened	350		20-10			20-10						

U

Schnittdaten Axialeinstechen

Cutting data Face grooving



Werkstoff Material	Härte Hardness Brinell (HB)	Schnittgeschwindigkeit v _c (m/min) Cutting speed v _c (m/min)												
		K10	MG12	P20	TI22 TN32	TI25 TN35	TA45 TH35	TA46	AS62	AS66	H20	H54		
P Kohlenstoffstahl Carbon steel	0,2% C	140			140-100	160-130	140-110	160-130	220-140	200-140	240-140	190-140	200-140	
	0,4% C	180			130-90	140-120	130-100	140-120	200-120	190-130	220-120	180-130	180-120	
	0,6% C	200			120-80	140-120	120-180		190-100	180-130	200-100	170-120	160-100	
	Legierter Stahl Alloyed steel (<5%)	geglüht annealed	180			120-80	140-120	140-100	140-120	190-80	160-120	200-80	170-120	180-120
		vergütet quenched	280			90-70	140-90	110-80		170-80	140-90	180-80	140-100	160-100
		vergütet quenched	350			60	120-70	80-60		140-60	110-80	160-70	120-60	120-80
	hochlegierter Stahl high alloyed steel (>5%)	geglüht annealed	200			100-60	100-70			160-120	150-100	180-120	110-80	100-90
		gehärtet hardened	-											
	Stahlguss Cast steel	unlegiert unalloyed	180				110-80				160-120	160-120	140-100	
		legiert alloyed	220				90-60				140-80	120-80	120-80	
M Rostfreier Stahl Stainless steel	martensitisch ferritisch martensitic, ferritic	200		80-60		110-80	110-50		160-100	130-110	150-120	150-100		
	austenitisch austenitic	180		60-40			80-60		120-100		110-80	140-100		
K Grauguss Grey cast iron	niedrige Festigkeit low tensile strength	180	70-50	70-50				110-70	140-100	140-100	160-100			
	hohe Festigkeit high tensile strength	250	70-50	70-50				80-60	120-80	120-80	140-100			
	Kugelgraphit- guss Spheroidal graphite cast iron	ferritisch ferritic	160				90-60	80-60	100-60	140-80	150-70	150-110		
		perlitisch perlitic	250				80-60	60-50	90-60	130-70	120-60	140-100		
Temperguss Malleable cast iron	ferritisch ferritic	125		80-60		120-100	80-60		100-80	160-110	180-100			
	perlitisch perlitic	225		60-40		80-60	60-50		80-60	120-80	150-120			
N Al-Legierungen Al-alloys	nicht vergütbar not heat treatable	30-80	1000-600	800-400			1000-600							
	vergütbar heat treatable	80-120	400-220	300-200			400-220							
	Al-Guss-Legie- rung Al-cast-alloy	nicht vergütbar not heat treatable	80	1000-600	800-400			1000-600						
		vergütbar heat treatable	100	600-300	400-250			600-300						
	Kupfer-Legie- rungen Copper-alloys	nicht vergütbar not heat treatable	90	160-100			160-130	190-110						
		vergütbar heat treatable	100	130-80			130-60	140-80						
S Warmfeste Legierung Heat resistant alloy (Fe)	geglüht annealed	200		40-30			40-30							
	gehärtet hardened	275		35-20			35-20							
	Warmfeste Legierung Heat resistant alloy (Ni, Co)	geglüht annealed	250		25-20			20-10						
		gehärtet hardened	350		20-10			20-10						

U

Schnittdaten Axialeinstechen Typ S15A/S25A

Cutting data Face grooving type S15A / S25A



Werkstoff Material		Härte Hardness Brinell (HB)	Schnittgeschwindigkeit v_c (m/min) Cutting speed v_c (m/min)	Vorschub f (mm/U) Feed rate f (mm/rev)			
			TH35				
P	Kohlenstoffstahl Carbon steel	0,2% C	140	110 - 140	0,02 - 0,05		
		0,4% C	180	100 - 130			
		0,6% C	200	90 - 120			
	Legierter Stahl Alloyed steel (<5%)	geglüht annealed	180	100 - 140	0,02 - 0,03		
		vergütet quenched	280	80 - 110			
		vergütet quenched	350	60 - 80			
	hochlegierter Stahl high alloyed steel (>5%)	geglüht annealed	200	60 - 80	0,02 - 0,03		
	Stahlguss Cast steel	unlegiert unalloyed	180	100 - 140	0,02 - 0,03		
legiert alloyed		220	80 - 110				
M	Rostfreier Stahl Stainless steel	martensitisch ferritisch martensitic, ferritic	200	50 - 120	0,02 - 0,03		
		austenitisch austenitic	180	50 - 110			
K	Grauguss Grey cast iron	niedrige Festigkeit low tensile strength	180	100 - 140	0,01 - 0,03		
		hohe Festigkeit high tensile strength	250	80 - 120			
	Kugelgraphitguss Spheroidal graphite cast iron	ferritisch ferritic	160	80 - 140			
		perlitisch perlitic	250	70 - 130			
	Temperguss Malleable cast iron	ferritisch ferritic	125	80 - 100			
		perlitisch perlitic	225	60 - 80			
N	Al-Legierungen Al-alloys	nicht vergütbar not heat treatable	30-80	100 - 600	0,01 - 0,08		
		vergütbar heat treatable	80-120	100 - 600			
	Al-Guss-Legierung Al-cast-alloy	nicht vergütbar not heat treatable	80	100 - 600			
		vergütbar heat treatable	100	100 - 600			
	Kupfer-Legierungen Copper-alloys	nicht vergütbar not heat treatable	90	110 - 190			
		vergütbar heat treatable	100	80 - 140			
	S	Warmfeste Legierung Heat resistant alloy (Fe)	geglüht annealed	200		30 - 40	0,01 - 0,02
			gehärtet hardened	275		20 - 35	
Warmfeste Legierung Heat resistant alloy (Ni, Co)		geglüht annealed	250	15 - 75			
		gehärtet hardened	350	18 - 40			

U

Schnittdaten Formeinstechen

Cutting data Profiling



Nominale Schnittgeschwindigkeit mit HORN-Sorten

Nominal cutting speeds with HORN grades

Werkstoff Material	Härte Hardness Brinell (HB)	* Schnittgeschwindigkeit v_c (m/min) *Cutting speed v_c (m/min)					
		MG12	TN35	TI25	TA45 / TH35		
P Kohlenstoffstahl, unlegiert Carbon steel, unalloyed	C < 0,4%	125	14-110	14-180	14-180	14-180	
	C > 0,4% < 0,6%	150	14-110	14-180	14-180	14-180	
	C > 0,6% < 0,8%	200	14-110	14-180	14-180	14-180	
	niedrig legierter Stahl low alloyed steel	geglüht annealed	180	16-90	16-150	16-150	
		vergütet quenched	275	16-90	16-150	16-150	
		vergütet quenched	160	16-90	16-150	16-150	
	hochlegierter Stahl high alloyed steel	geglüht annealed	200		19-90	19-90	
		vergütet quenched	325		19-90	19-90	
	Stahlguss Cast steel	unlegiert unalloyed	180	19-110	19-180	19-180	
		niedrig legiert low alloyed	200	19-110	19-180	19-180	
hoch legiert high alloyed		225	19-110	19-180	19-180		
M Rostfreier Stahl Stainless steel	martensitisch ferritisch, geblüht martensitic, ferritic, annealed	200		19-90	19-90		
	austenitisch austenitic Ni>8%/Cr 18-20%	180		16-80			
N Al-Legierungen Al-alloys			14-220	16-600	16-600		
	Kupfer- und Messinglegierung Copper and brass alloys		14-220	14-700	14-700		
S Warmfeste Legierung Heat resistant alloy	NiFe				18-75	18-75	
	NiCo				18-40	18-40	

v_c ist abhängig vom Bohrungsdurchmesser und damit von der Höchstdrehzahl der Maschine.

v_c is depending on the bore diameter and therefore of the maximum numbers of revolutions of the machine.



HM-Sorten für Ein- und Abstechen

Carbide grades for grooving and parting off

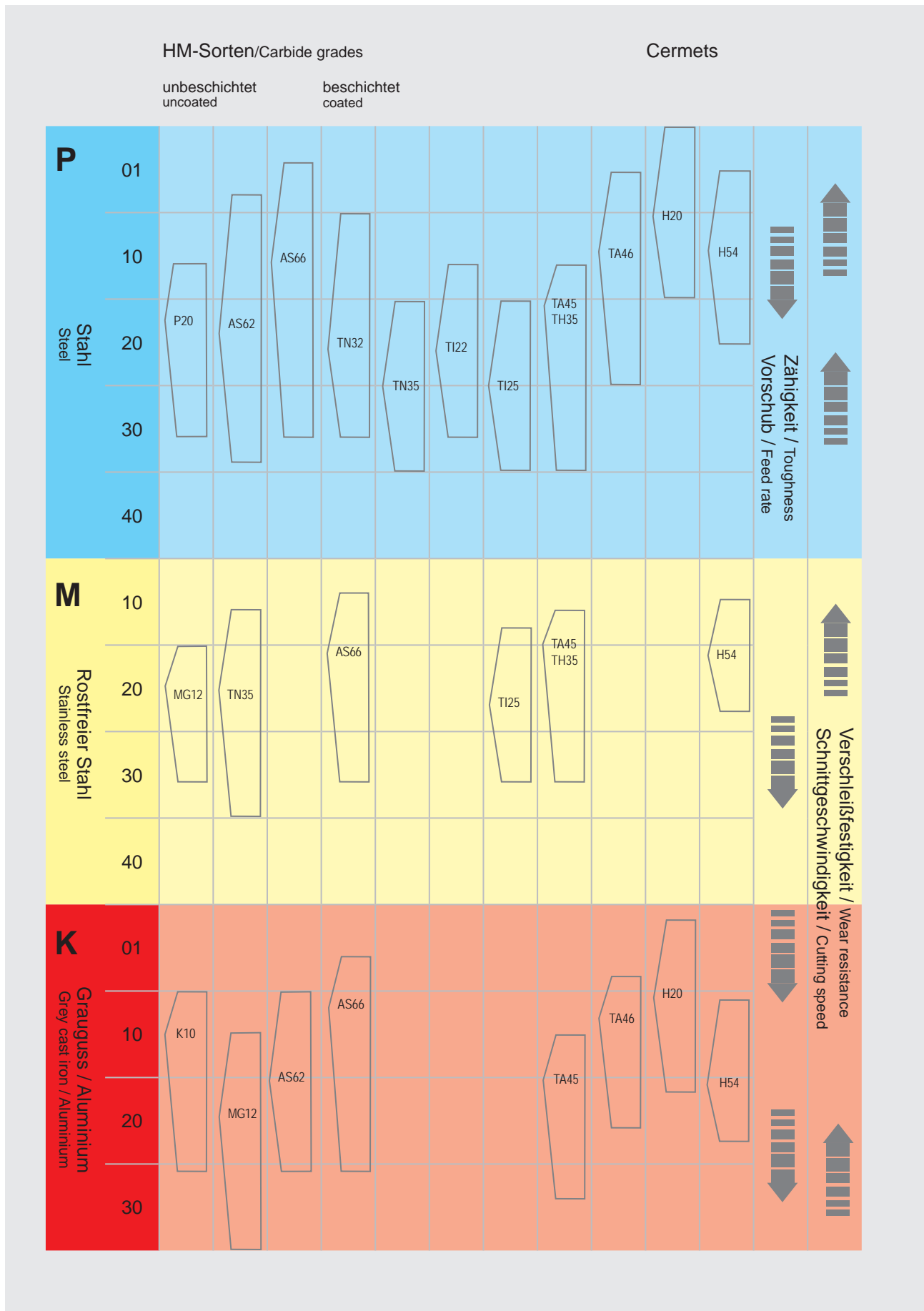

U

HM-Sorten für Ein- und Abstechen

Carbide grades for grooving and parting off

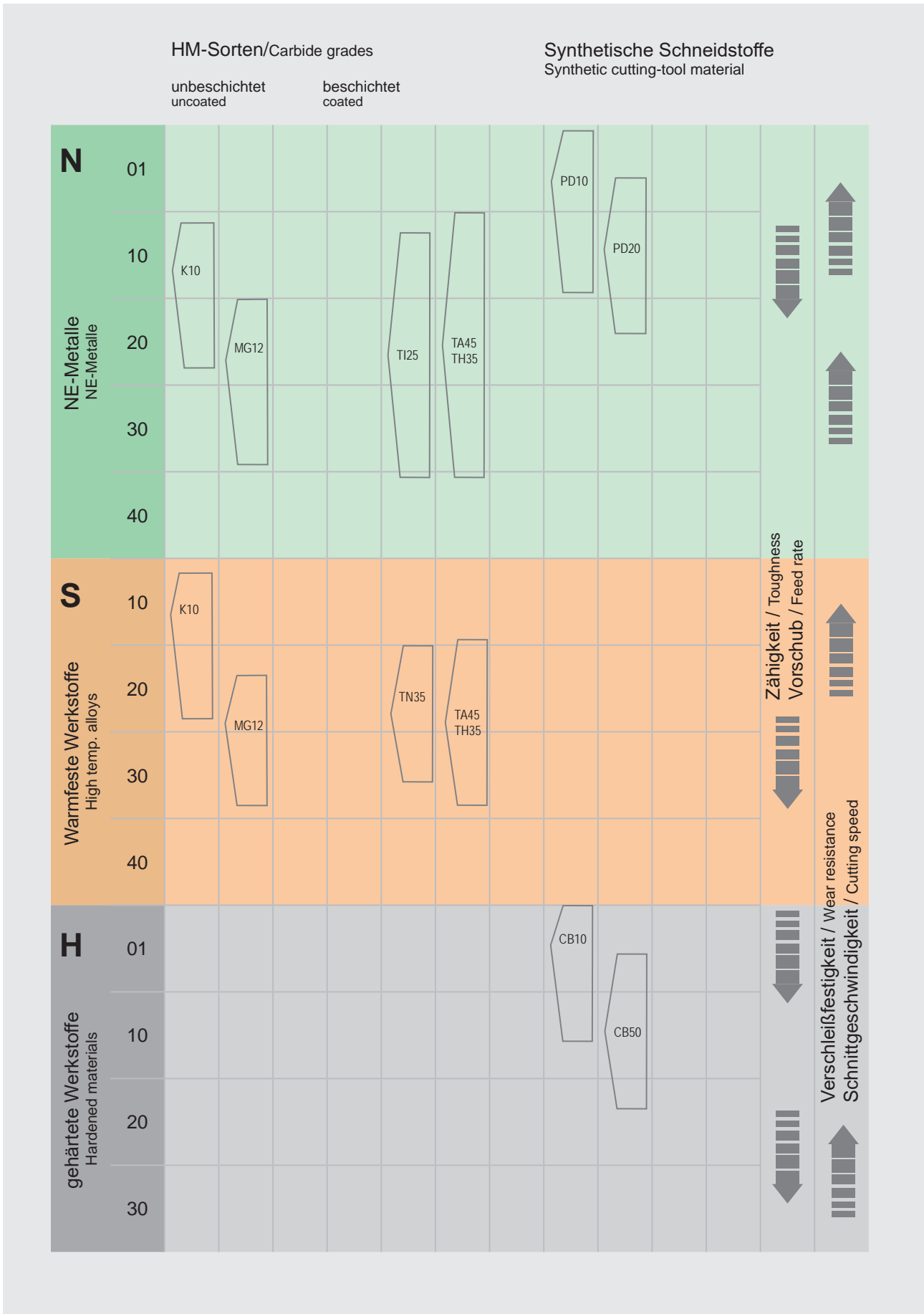

HORN-Sorten	ISO513	Eigenschaften	bearbeitbare Werkstoffe	Anwendungsgebiete
H20	HT	Cermet	unlegierte C-Stähle, niedrig legierte Stähle, Stahlguss, rostfreie Stähle, exotische Legierungen	zum Vor- und Fertigstechen mit hervorragender Oberflächengüte, neigt nicht zur Aufbauschneidenbildung, verschleißfest
H54	HT	Cermet	unlegierte C-Stähle, niedrig legierte Stähle, Stahlguss, rostfreie Stähle, exotische Legierungen	zum Vor- und Fertigstechen mit hervorragender Oberflächengüte, neigt nicht zur Aufbauschneidenbildung, verschleißfest
P20	HW	unbeschichtetes Hartmetall	Stahl, Stahlguss, Temperguss	zum Vor- und Fertigstechen bei mittlerer Schnittgeschwindigkeit
AS62	HC	TiAlN-Beschichtung	Stahl, Stahlguss, Temperguss	zum Vor- und Fertigstechen bei hoher Schnittgeschwindigkeit
AS66	HC	TiAlN-Beschichtung	Stahl, Stahlguss, Temperguss, martensitischer rostfreier Stahl	zum Vor- und Fertigstechen bei hoher Schnittgeschwindigkeit, warmfest, geeignet für Trockenbearbeitung
AL96	HC	Mehrlagenbeschichtungen(Al ₂ O ₃)	Stahl, Stahlguss, Temperguss, martensitischer rostfreier Stahl	zum Vor- und Fertigstechen bei sehr hoher Schnittgeschwindigkeit, warmfest, geeignet für Trockenbearbeitung
TN32	HC	TiN-Beschichtung	Stahl, Stahlguss, Temperguss	zum Vor- und Fertigstechen bei hoher Schnittgeschwindigkeit
TN35	HC	TiN-Beschichtung	Stahl, Stahlguss, Temperguss, martensitischer rostfreier Stahl	zum Vor- und Fertigstechen bei niedriger bis mittlerer Schnittgeschwindigkeit, Gewindedrehen, ungünstige Bedingungen
TI22	HC	TiCN-Beschichtung	Stahl, Stahlguss, Temperguss	zum Vor- und Fertigstechen bei hoher Schnittgeschwindigkeit
TI25	HC	TiCN-Beschichtung	Stahl, Stahlguss, Temperguss, martensitischer rostfreier Stahl	zum Vor- und Fertigstechen bei niedriger Schnittgeschwindigkeit, Gewindedrehen, ungünstige Bedingungen
TH35 AS6G	HC	TiAlN-Beschichtung	Stahl, Stahlguss, Temperguss, martensitischer rostfreier Stahl	zum Vor- und Fertigstechen bei hoher Schnittgeschwindigkeit, warmfest, geeignet für Trockenbearbeitung
TA45 TF45	HC	TiAlN-Beschichtung	Stahl, Stahlguss, Temperguss, martensitischer rostfreier Stahl	zum Vor- und Fertigstechen bei niedriger Schnittgeschwindigkeit, Kühlung durch Öl
TA46 TF46	HC	TiAlN-Beschichtung	Stahl, Stahlguss, Temperguss, martensitischer rostfreier Stahl	zum Vor- und Fertigstechen bei hoher Schnittgeschwindigkeit, warmfest, geeignet für Trockenbearbeitung
K10	HW	unbeschichtetes Hartmetall	Grauguss, Temperguss, Si-Aluminium- und Kupferlegierungen, hochhitzebeständige Legierungen	zum Vor- und Fertigstechen
MG12	HF	unbeschichtetes Hartmetall (Feinkorn)	Grauguss, Temperguss, Aluminium- und Kupferlegierungen, hochhitzebeständige Legierungen	zum Vor- und Fertigstechen bei niedriger Schnittgeschwindigkeit, ungünstige Bedingungen

PKD- oder CBN-bestückte Schneidplatten auf Anfrage lieferbar..

Lagerhaltige HM-Sorten sind im Katalog bzw. in der Preis- und Lagerliste aufgeführt. Nicht aufgeführte HM-Sorten können auf Bestellung gefertigt werden.

Description carbide grades



HORN-Grades	ISO513	Properties	Workpiece material	Recommended applications
H20	HT	Cermet	carbon steels, low alloyed steels, cast steel, stainless steel, exotic alloys	for grooving and finishing, for best surface qualities, no tendency to built up edge, resistant to wear
H54	HT	Cermet	carbon steels, low alloyed steels, cast steel, stainless steel, exotic alloys	for grooving and finishing, for best surface qualities, no tendency to built up edge, resistant to wear
P20	HW	uncoated grades	steel, cast steel, malleable cast iron	for grooving and finishing at moderate cutting speed
AS62	HC	TiAlN-Coating	steel, cast steel, malleable cast iron,	for grooving and finishing at high cutting speed
AS66	HC	TiAlN-Coating	steel, cast steel, malleable cast iron, martensitic stainless steel	for grooving and finishing, at high cutting speed, heat resistant, suitable for dry cutting
AL96	HC	multilayer coating (AL ₂ O ₃)	steel, cast steel, malleable cast iron, martensitic stainless steel	for grooving and finishing, at very high cutting speed, heat resistant, suitable for dry cutting
TN32	HC	TiN-Coating	steel, cast steel, malleable cast iron	for grooving and finishing, at high cutting speed
TN35	HC	TiN-Coating	steel, cast steel, malleable cast iron, martensitic stainless steel	for grooving and finishing, at low cutting speed, thread cutting, unfavourable conditions
TI22	HC	TiCN-Coating	steel, cast steel, malleable cast iron	for grooving and finishing at high cutting speed
TI25	HC	TiCN-Coating	steel, cast steel, malleable cast iron, martensitic stainless steel	for grooving and finishing, at low cutting speed, thread cutting, unfavourable conditions
TH35 AS6G	HC	TiAlN-Coating	steel, cast steel, malleable cast iron, martensitic stainless steel	for grooving and finishing, at high cutting speed, heat resistant, suitable for dry cutting
TA45 TF45	HC	TiAlN-Coating	steel, cast steel, malleable cast iron, martensitic stainless steel	for grooving and finishing at low cutting speed, cooling with oil
TA46 TF46	HC	TiAlN-Coating	steel, cast steel, malleable cast iron, martensitic stainless steel	for grooving and finishing, at high cutting speed, heat resistant, suitable for dry cutting
K10	HW	uncoated grades	grey cast iron, malleable cast iron, Si-aluminium and copper alloys, heat resistant alloys	for grooving and finishing
MG12	HF	uncoated grades (micro grain)	grey cast iron, malleable cast iron, aluminium and copper alloys, heat resistant alloys	for grooving and finishing, at low cutting speed, unfavourable conditions

PCD- or PCBN-tipped inserts upon request..

Carbide grades on stock are shown in the catalogue or in the price- and stocklist..
Not mentioned grades can be supplied only against firm order..

U

Beschreibung Hartmetall-Sorten

Description carbide grades



HORN-Sorten	ISO513	bearbeitbare Werkstoffe	Anwendungsgebiete
CB07	BN	gehärteter Stahl > 56 HRC, nicht unterbrochener Schnitt	Stechen ins Volle vc ≈ 150 m/min, f = 0,03 - 0,04 mm
			Schlichten bei ap 0,1 - 0,2 mm vc ≈ 160 m/min, f = 0,04 - 0,08 mm
CB10	BN	gehärteter Stahl > 56 HRC, nicht unterbrochener Schnitt	Stechen ins Volle vc ≈ 140 m/min, f = 0,03 - 0,04 mm
			Schlichten bei ap 0,1 - 0,2 mm vc ≈ 150 m/min, f = 0,04 - 0,08 mm
CB50	BN	gehärteter Stahl > 45 HRC, unterbrochener Schnitt	Stechen ins Volle vc ≈ 140 m/min, f = 0,03 - 0,04 mm
			Schlichten bei ap 0,1 - 0,2 mm vc ≈ 150 m/min, f = 0,04 - 0,08 mm
		Grauguss, perlitisch	Stechen ins Volle vc ≈ 1200 m/min, f = 0,1 - 0,25 mm
			Teilschnitt bei ap 0,3 - 1,0 mm vc ≈ 1300 m/min, f = 0,2 - 0,4 mm
Kugelgraphitguss	Stechen ins Volle vc ≈ 900 m/min, f = 0,07 - 0,2 mm		
	Teilschnitt bei ap 0,1 - 0,7 mm vc ≈ 1000 m/min, f = 0,1 - 0,3 mm		
PKD- oder CBN-bestückte Schneidplatten auf Anfrage lieferbar..			
Lagerhaltige HM-Sorten sind im Katalog bzw. in der Preis- und Lagerliste aufgeführt. Nicht aufgeführte HM-Sorten können auf Bestellung gefertigt werden.			

U

HORN-Grades	ISO513	Workpiece material	Recommended applications
CB07	BN	hardened Steel > 56 HRC, non interrupted cut	Grooving in full material vc ≈ 150 m/min, f = 0,03 - 0,04 mm
			Finishing with ap 0,1 - 0,2 mm vc ≈ 160 m/min, f = 0,04 - 0,08 mm
CB10	BN	hardened Steel > 56 HRC, non interrupted cut	Grooving in full material vc ≈ 140 m/min, f = 0,03 - 0,04 mm
			Finishing with ap 0,1 - 0,2 mm vc ≈ 150 m/min, f = 0,04 - 0,08 mm
CB50	BN	hardened Steel > 45 HRC, interrupted cut	Grooving in full material vc ≈ 140 m/min, f = 0,03 - 0,04 mm
			Finishing with ap 0,1 - 0,2 mm vc ≈ 150 m/min, f = 0,04 - 0,08 mm
		Grey cast iron, perlitic	Grooving in full material vc ≈ 1200 m/min, f = 0,1 - 0,25 mm
			Partial cut with ap 0,3 - 1,0 mm vc ≈ 1300 m/min, f = 0,2 - 0,4 mm
Spheroidal graphite cast iron	Grooving in full material vc ≈ 900 m/min, f = 0,07 - 0,2 mm		
	Partial cut with ap 0,1 - 0,7 mm vc ≈ 1000 m/min, f = 0,1 - 0,3 mm		
PCD- or PCBN-tipped inserts upon request..			
Carbide grades on stock are shown in the catalogue or in the price- and stocklist. Not mentioned grades can be supplied only against firm order..			



System	Seite/Seite
N105/N110	V2
S117	V20



Klemmhalter
Toolholder
SB105/SB105 /
B105/SB110

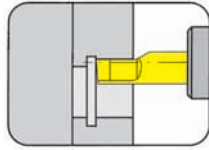

Seite/Page
V4-V11

Schneidplatte
Insert
N105/N110

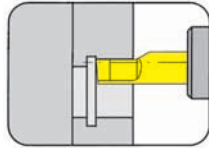

Seite/Page
V12-V17

N105/N110



**Klemmhalter mit
Schneidplatten**

Bohrungs-Ø ab 6 mm

**Toolholder with
Inserts**

Bore Ø from 6 mm

V

Klemmhalter

Toolholder

SB105

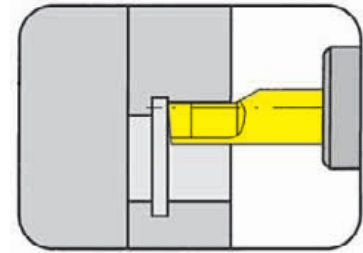

Bohrungs-Ø ab	Bore Ø from	6 mm
---------------	-------------	------

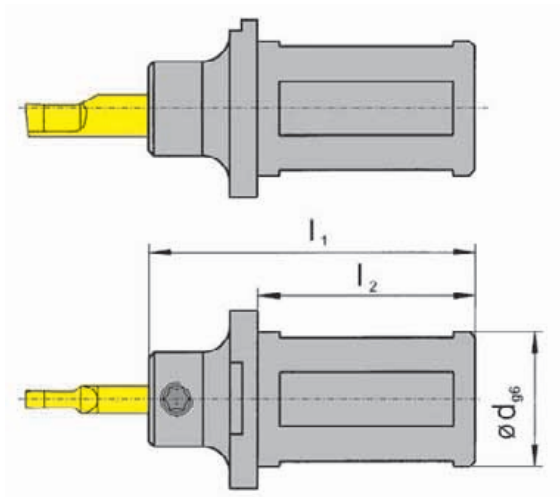

für Schneidplatte
for Insert

Typ N105
Type

Bestellnummer Part number	d	l ₁	l ₂	D _{min}
SB105.0016.1.01	16	60	40	6
SB105.0020.1.01	20	60	40	6
SB105.0022.1.01	22	60	40	6
SB105.0025.1.01	25	60	40	6

Weitere Abmessungen auf Anfrage
Further sizes upon request

Abmessungen in mm
Dimensions in mm

Einspannlänge der Platten = 12 mm!
Clamping length of inserts = 12 mm!

Das Anzugsdrehmoment der Schrauben finden Sie in den Technischen Hinweisen.
For torque specification of the screw, please see Technical Instructions.

Ersatzteile

Spare Parts

Klemmhalter Toolholder	Spannschraube Screw	TORX PLUS®-Schlüssel TORX PLUS® Wrench
SB105...	6.075T15P	T15PQ

Klemmhalter

Toolholder

SB105

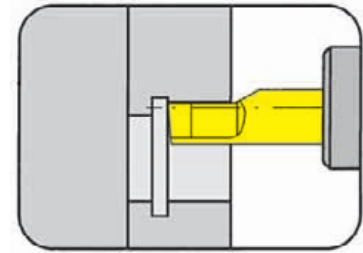

Bohrungs-Ø ab	Bore Ø from	6 mm
---------------	-------------	------

nur für Nutstoßgeräte EWS-Slot und BENZ LinA
only usable for broaching devices EWS-Slot and BENZ LinA

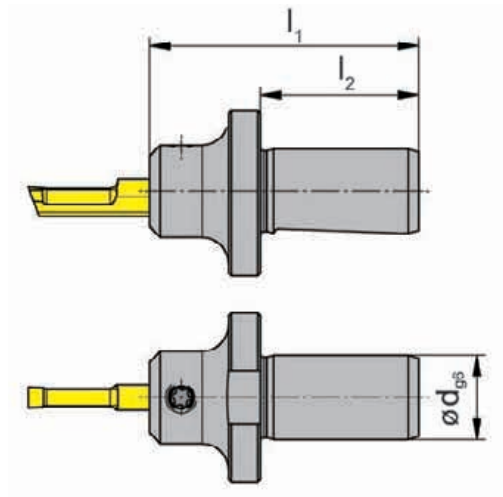

für Schneidplatte
for Insert

Typ N105
Type

Bestellnummer Part number	d	l ₁	l ₂	D _{min}
SB105.0016.E1.01	16	51	30	6

Ausführungen für weitere Geräteschnittstellen auf Anfrage
Further sizes for other device interfaces upon request

Abmessungen in mm
Dimensions in mm

Einspannlänge der Platten = 12 mm!

Clamping length of inserts = 12 mm!

Das Anzugsdrehmoment der Schrauben finden Sie in den Technischen Hinweisen.
For torque specification of the screw, please see Technical Instructions.

Ersatzteile

Spare Parts

Klemmhalter Toolholder	Spannschraube Screw	TORX PLUS®-Schlüssel TORX PLUS® Wrench
SB105.0016.E1.01	6.075T15P	T15PQ

Klemmhalter

Toolholder

B105

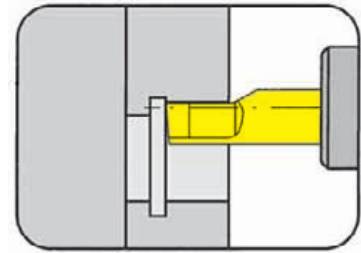

Bohrungs-Ø ab	Bore Ø from	6 mm
---------------	-------------	------

für Nutstoßgerät Firma Schwarzer
for broaching device Schwarzer

für Schneidplatte
for Insert

Typ N105
Type

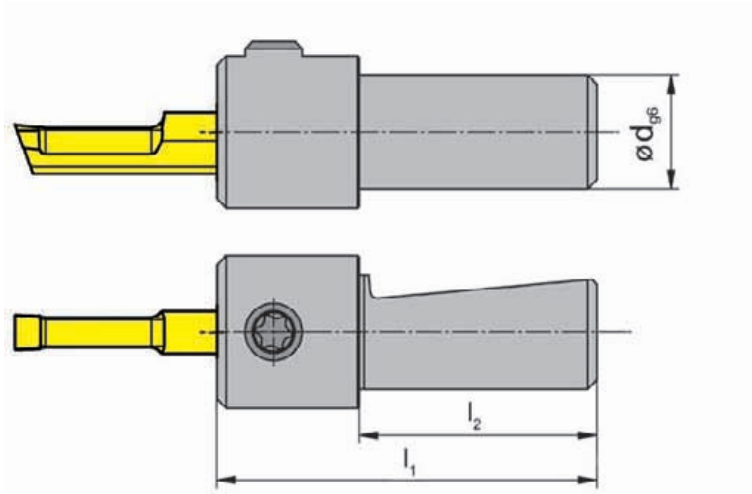

Bestellnummer Part number	d	l ₁	l ₂	D _{min}
B105.0012.0220	12	40	25	6

Ausführungen für weitere Geräteschnittstellen auf Anfrage
Further sizes for other device interfaces upon request

Abmessungen in mm
Dimensions in mm

Einspannlänge der Platten = 12 mm!

Clamping length of inserts = 12 mm!

Das Anzugsdrehmoment der Schrauben finden Sie in den Technischen Hinweisen.
For torque specification of the screw, please see Technical Instructions.

V

Ersatzteile

Spare Parts

Klemmhalter Toolholder	Spannschraube Screw	TORX PLUS®-Schlüssel TORX PLUS® Wrench
B105.0012.0220	6.075T15P	T15PQ

Klemmhalter

Toolholder

SB105/SB110

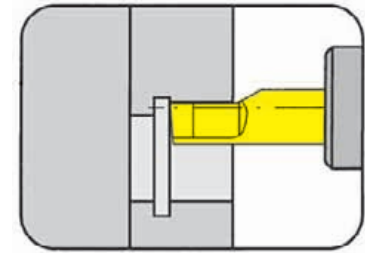

Bohrungs-Ø ab	Bore Ø from	6 mm
---------------	-------------	------

für WTO Stoßeinheit
for broaching device WTO

für Schneidplatte
for Insert

Typ N105
Type N110

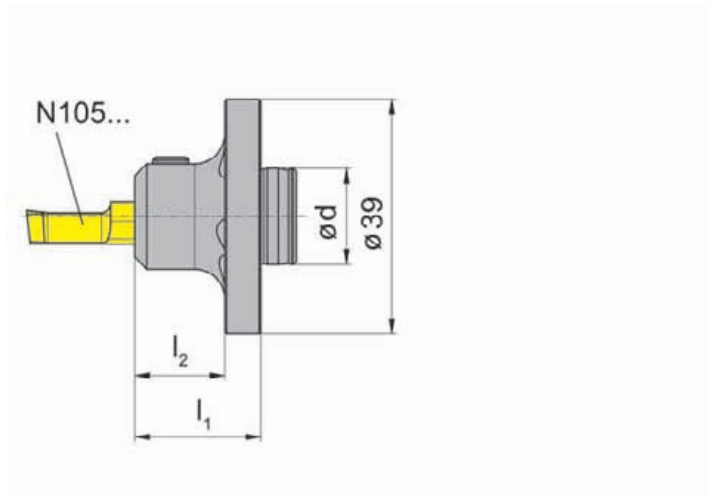

Bestellnummer Part number	d	l ₁	l ₂	D _{min}
SB105.1816.W1.01	16	21	15	6
SB110.2016.W1.02	16	42	36	9

Ausführungen für weitere Geräteschnittstellen auf Anfrage
Further sizes for other device interfaces upon request

Abmessungen in mm
Dimensions in mm

Das Anzugsdrehmoment der Schrauben finden Sie in den Technischen Hinweisen.
For torque specification of the screw, please see Technical Instructions.



Ersatzteile

Spare Parts

Klemmhalter Toolholder	Spannschraube Screw	TORX PLUS®-Schlüssel TORX PLUS® Wrench
SB105...	6.075T15P	T15PQ

Klemmhalter

Toolholder

SB105/SB110

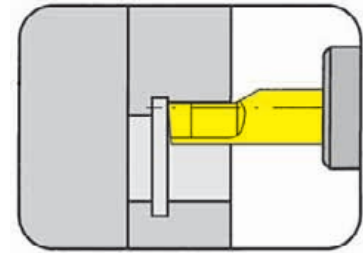

Bohrungs-Ø ab	Bore Ø from	6 mm
---------------	-------------	------

für Nutstoßgerät Firma Schwarzer „2in1“
for broaching device Schwarzer „2in1“

für Schneidplatte
for Insert

Typ N105
Type N110

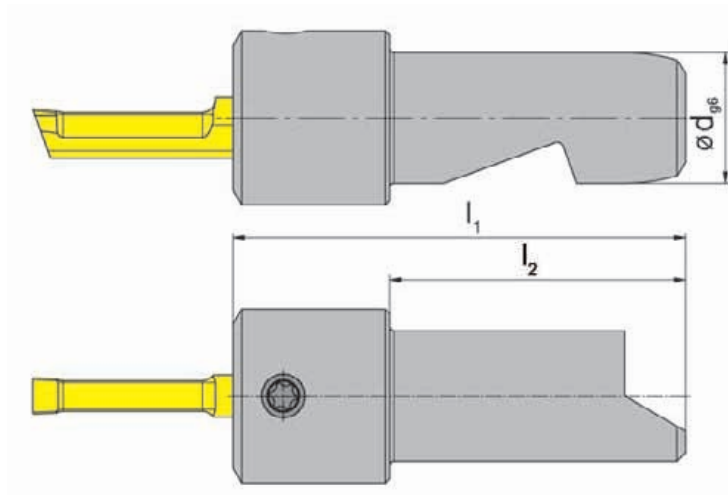

Bestellnummer Part number	d	l ₁	l ₂	D _{min}
SB105.0015.S1.01	15	52	34	6
SB110.0015.S1.02	15	66	34	9

Ausführungen für weitere Geräteschnittstellen auf Anfrage
Further sizes for other device interfaces upon request

Abmessungen in mm
Dimensions in mm

Einspannlänge der Platten = 12 mm (105) / 26 mm (110)!
Clamping length of inserts = 12 mm (105) / 26 mm (110)!

Das Anzugsdrehmoment der Schrauben finden Sie in den Technischen Hinweisen.
For torque specification of the screw, please see Technical Instructions.

V

Ersatzteile

Spare Parts

Klemmhalter Toolholder	Spannschraube Screw	TORX PLUS®-Schlüssel TORX PLUS® Wrench
SB105...	6.075T15P	T15PQ

Klemmhalter

Toolholder

SB105/SB110

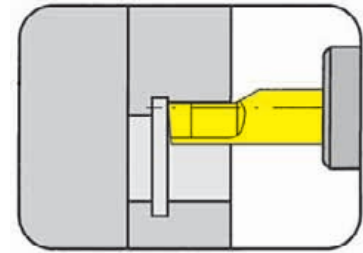

Bohrungs-Ø ab	Bore Ø from	6 mm
---------------	-------------	------

für Nutstoßgerät AR2P
for broaching device AR2P

für Schneidplatte
for Insert

Typ N105
Type N110

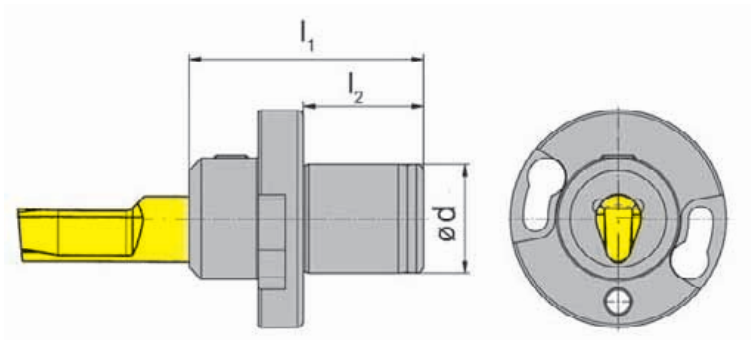

Bestellnummer Part number	d	l ₁	l ₂	D _{min}
SB105.0018.A.01	18	38	20	6
SB110.0018.A.01	18	39	20	6
SB110.0018.A.02	18	52	20	6

Ausführungen für weitere Geräteschnittstellen auf Anfrage
Further sizes for other device interfaces upon request

Abmessungen in mm
Dimensions in mm

Einspannlänge der Platten = 12 mm (105) / 26 mm (110)!
Clamping length of inserts = 12 mm (105) / 26 mm (110)!

Das Anzugsdrehmoment der Schrauben finden Sie in den Technischen Hinweisen.
For torque specification of the screw, please see Technical Instructions.

Ersatzteile

Spare Parts

Klemmhalter Toolholder	Spannschraube Screw	TORX PLUS®-Schlüssel TORX PLUS® Wrench
SB105...	6.075T15P	T15PQ



Klemmhalter

Toolholder

SB110

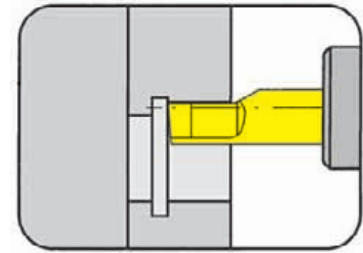

Bohrungs-Ø ab	Bore Ø from	9 mm
---------------	-------------	------

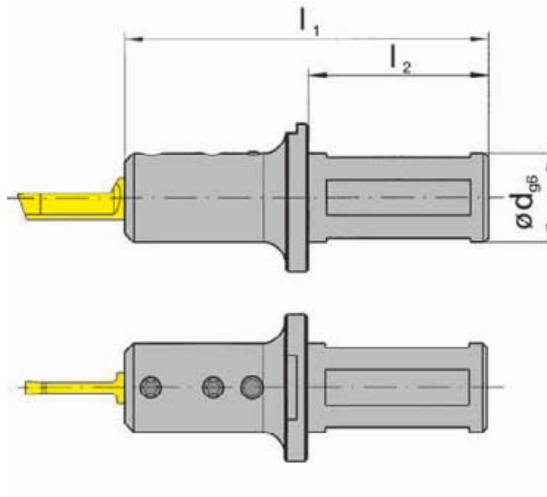

für Schneidplatte
for Insert

Typ N110
Type

Bestellnummer Part number	d	l ₁	l ₂	D _{min}
SB110.0025.1.02	25	81	40	9
SB110.0032.1.02	32	81	40	9

Weitere Abmessungen auf Anfrage
Further sizes upon request

Abmessungen in mm
Dimensions in mm

Einspannlänge der Platten = 26 mm!

Clamping length of inserts = 26 mm!

Das Anzugsdrehmoment der Schrauben finden Sie in den Technischen Hinweisen.
For torque specification of the screw, please see Technical Instructions.

Ersatzteile

Spare Parts

Klemmhalter Toolholder	Spannschraube Screw	TORX PLUS®-Schlüssel TORX PLUS® Wrench
SB110...	6.075T15P	T15PQ



Klemmhalter

Toolholder

SB110

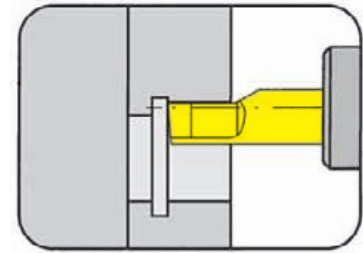

Bohrungs-Ø ab	Bore Ø from	9 mm
---------------	-------------	------

nur für Nutstoßgeräte EWS-Slot und BENZ LinA
only usable for broaching devices EWS-Slot and BENZ LinA

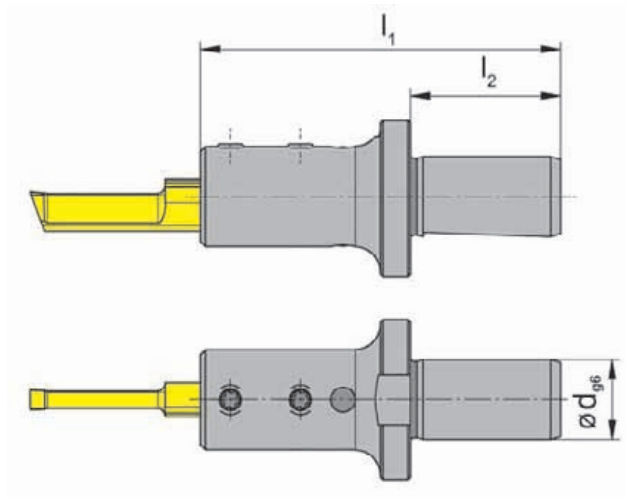

für Schneidplatte
for Insert

Typ N110
Type

Bestellnummer Part number	d	l ₁	l ₂	D _{min}
SB110.0016.E1.02	16	72	30	9

Ausführungen für weitere Geräteschnittstellen auf Anfrage
Further sizes for other device interfaces upon request

Abmessungen in mm
Dimensions in mm

Einspannlänge der Platten = 26 mm!

Clamping length of inserts = 26 mm!

Das Anzugsdrehmoment der Schrauben finden Sie in den Technischen Hinweisen.
For torque specification of the screw, please see Technical Instructions.

Ersatzteile

Spare Parts

Klemmhalter Toolholder	Spannschraube Screw	TORX PLUS®-Schlüssel TORX PLUS® Wrench
SB110.0016.E1.02	6.075T15P	T15PQ



Schneidplatte

Insert

N105/N110

Toleranzklasse C11
Tolerance grade C11

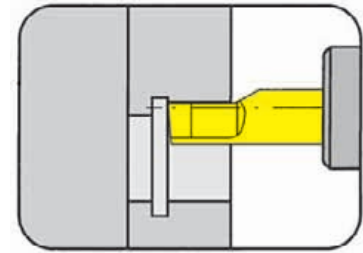

Bohrungs-Ø ab	Bore Ø from	6 mm
---------------	-------------	------

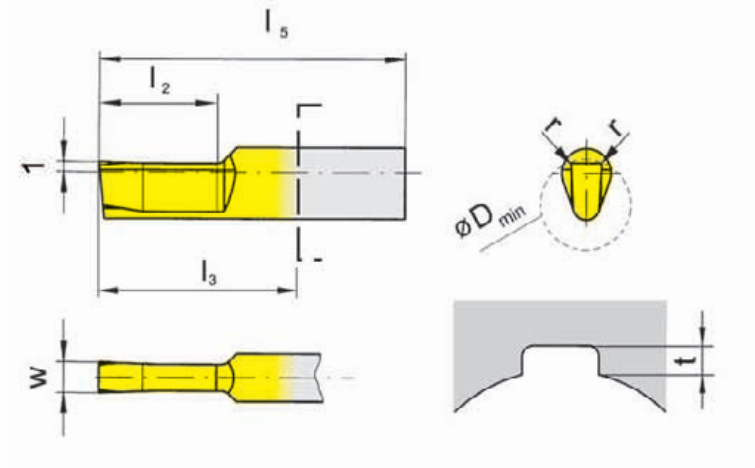

für Klemhalter
for Toolholder

Typ SB105
Type B105
SB110

Längsnuten nach DIN138
Keyways according to DIN138

Bestellnummer Part number	w	l ₅	l ₂	l ₃	r	Einsetzbar ab Ø Applicable from Ø	TA45
N105.0210.2.08	2,11	30	12	18	0,35	6,0	▲
N105.0310.2.10	3,11	30	12	18	0,35	6,5	▲
N105.0310.2.13	3,11	30	12	18	0,50	6,5	▲
N105.0410.2.16	4,13	30	12	18	0,50	6,5	▲
N110.0410.05.04	4,13	60	25	34	0,50	9,0	▲
N110.0410.05.07	4,13	75	40	49	0,50	9,0	▲
N110.0510.05.04	5,13	60	25	34	0,50	9,0	▲
N110.0510.05.07	5,13	75	40	49	0,50	9,0	▲

▲ ab Lager / on stock Δ 4 Wochen / 4 weeks x auf Anfrage / upon request

● empfohlen / recommended

o bedingt einsetzbar / alternative recommendation

- nicht geeignet / not suitable

■ unbeschichtete HM-Sorten / uncoated grades

■ beschichtete HM-Sorten / coated grades

■ bestückt/Cermet / brazed/Cermet

Abmessungen in mm

Dimensions in mm

Bestellhinweis:

Die Nutabmessungen nach DIN finden Sie auf Seite V18

Ordering note:

For Dimensions of Groove DIN please see page V18

P	•
M	•
K	•
N	•
S	•
H	-

HM-Sorten
Carbide grades

Schneidplatte

Insert

N105/N110

Toleranzklasse P9
Tolerance grade P9

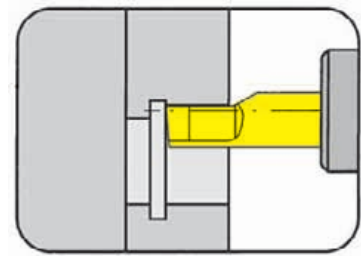

Bohrungs-Ø ab	Bore Ø from	6 mm
---------------	-------------	------

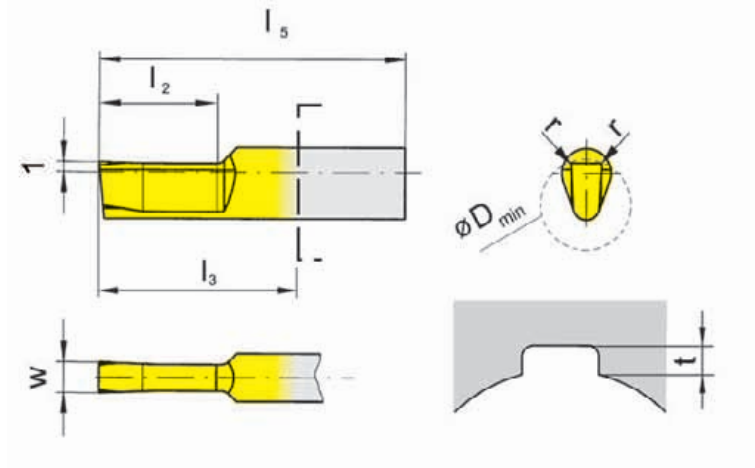

für Klemmhalter
for Toolholder

Typ SB105
Type B105
SB110

Längsnuten nach DIN6885
Keyways according to
DIN6885

Bestellnummer Part number	w	l ₅	l ₂	l ₃	r	Einsetzbar ab Ø Applicable from Ø	TA45
N105.0198.01.01	1,982	30	12	18	0,1	6,0	▲
N105.0298.01.01	2,982	30	12	18	0,1	6,5	▲
N105.0397.01.01	3,973	35	15	23	0,1	6,5	▲
N110.0397.02.04	3,976	60	25	34	0,2	9,0	▲
N110.0397.02.07	3,976	75	40	49	0,2	9,0	▲
N110.0497.02.04	4,976	60	25	34	0,2	9,0	▲
N110.0497.02.07	4,976	75	40	49	0,2	9,0	▲

▲ ab Lager / on stock Δ 4 Wochen / 4 weeks x auf Anfrage / upon request

● empfohlen / recommended

o bedingt einsetzbar / alternative recommendation

- nicht geeignet / not suitable

■ unbeschichtete HM-Sorten / uncoated grades

■ beschichtete HM-Sorten / coated grades

■ bestückt/Cermet / brazed/Cermet

Abmessungen in mm

Dimensions in mm

Bestellhinweis:

Die Nutabmessungen nach DIN finden Sie auf Seite V18

Ordering note:

For Dimensions of Groove DIN please see page V18

P	•
M	•
K	•
N	•
S	•
H	-

HM-Sorten
Carbide grades



Schneidplatte

Insert

N105/N110

Toleranzklasse JS9
Tolerance grade JS9

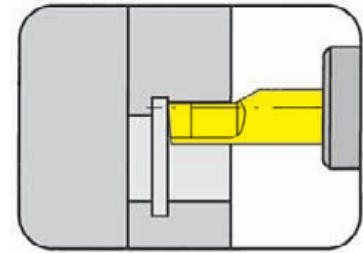

Bohrungs-Ø ab	Bore Ø from	6 mm
---------------	-------------	------

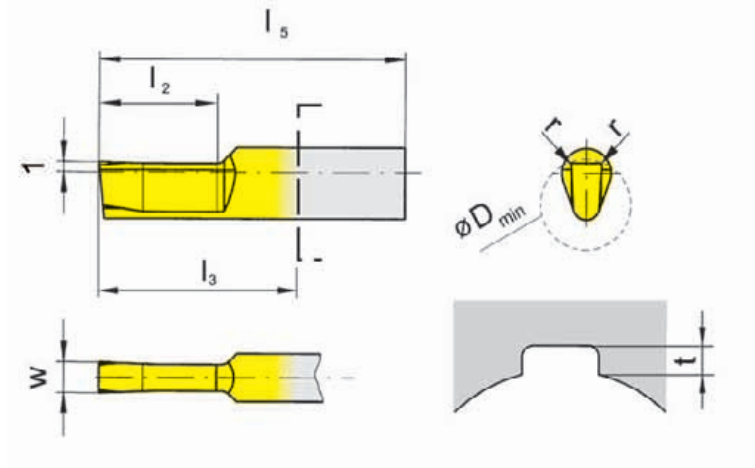

für Klemhalter
for Toolholder

Typ SB105
Type B105
SB110

Längsnuten nach DIN6885
Keyways according to
DIN6885

Bestellnummer Part number	w	l ₅	l ₂	l ₃	r	Einsetzbar ab Ø Applicable from Ø	TA45
N105.0200.01.01	2	30	12	18	0,1	6,0	▲
N105.0300.01.01	3	30	12	18	0,1	6,5	▲
N105.0400.01.01	4	35	15	23	0,1	6,5	▲
N105.0400.02.01	4	35	15	23	0,2	6,5	▲
N110.0400.02.04	4	60	25	34	0,2	9,0	▲
N110.0400.02.07	4	75	40	49	0,2	9,0	▲
N110.0500.02.04	5	60	25	34	0,2	9,0	▲
N110.0500.02.07	5	75	40	49	0,2	9,0	▲

▲ ab Lager / on stock Δ 4 Wochen / 4 weeks x auf Anfrage / upon request

● empfohlen / recommended

o bedingt einsetzbar / alternative recommendation

- nicht geeignet / not suitable

■ unbeschichtete HM-Sorten / uncoated grades

■ beschichtete HM-Sorten / coated grades

■ bestückt/Cermet / brazed/Cermet

Abmessungen in mm

Dimensions in mm

Bestellhinweis:

Die Nutabmessungen nach DIN finden Sie auf Seite V18

Ordering note:

For Dimensions of Groove DIN please see page V18

P	•
M	•
K	•
N	•
S	•
H	-

HM-Sorten
Carbide grades

Schneidplatte

Insert

N105/N110

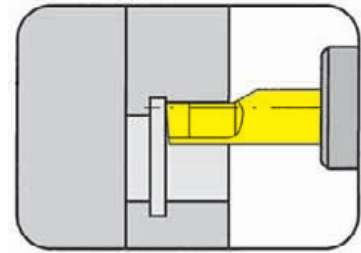

Bohrungs-Ø ab	Bore Ø from	6 mm
---------------	-------------	------

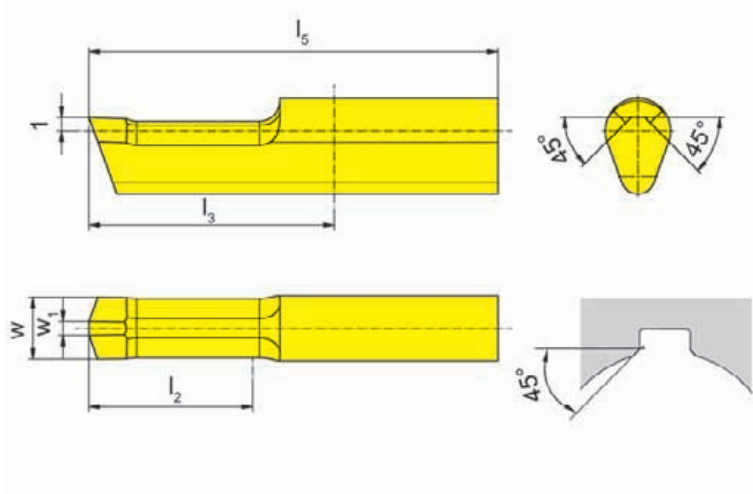

für Klemhalter
for Toolholder

Typ SB105
Type B105
SB110

Fasen
Chamfering

Bestellnummer Part number	w	w1	l ₅	l ₂	l ₃	D _{min}	Einsetzbar ab Ø Applicable from Ø	TA45
N105.4545.2.6	4,5	1	30	12	18	6	6	▲
N105.4545.3.6	4,5	1	35	20	23	6	6	▲
N110.4545.4.9	6,3	2	60	25	34	9	9	▲
N110.4545.7.9	6,3	2	75	40	49	9	9	▲

▲ ab Lager / on stock Δ 4 Wochen / 4 weeks x auf Anfrage / upon request

● empfohlen / recommended

o bedingt einsetzbar / alternative recommendation

- nicht geeignet / not suitable

■ unbeschichtete HM-Sorten / uncoated grades

■ beschichtete HM-Sorten / coated grades

■ bestückt/Cermet / brazed/Cermet

Abmessungen in mm

Dimensions in mm

P	•
M	•
K	•
N	•
S	•
H	-

HM-Sorten
Carbide grades



Nutstoßen - Innensechskant

Broaching - Hexagon Socket



Schneidplatte

Insert

N105/N110

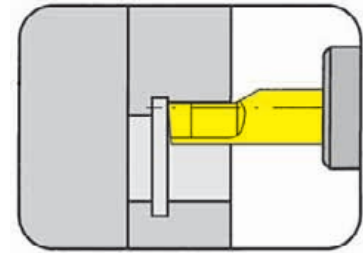

Innensechskant ab Hexagon socket from SW 2

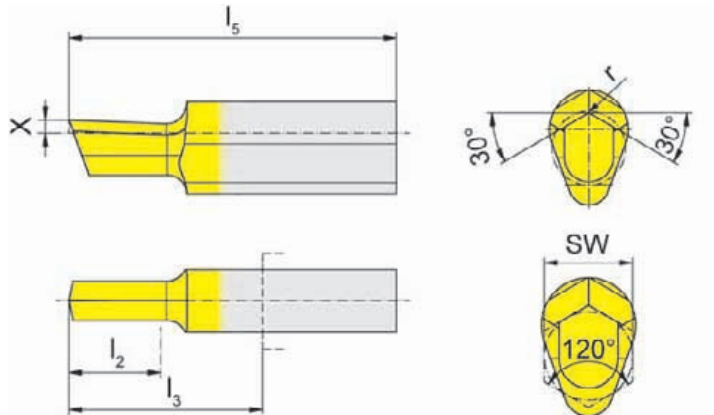

für Klemhalter
for Toolholder

Typ SB105
Type B105
SB110

Innensechskant
Hexagon socket

Bestellnummer Part number	l_5	l_2	l_3	r	X	SW	Grundbohrung Pilot \varnothing	TA45
N105.SW20.20.01	25	4,0	13	0,05	1,0	2,0	SW	▲
N105.SW25.25.01	25	4,0	13	0,05	1,0	2,5 - 2,9	SW	▲
N105.SW30.30.01	25	4,5	13	0,05	1,0	2,9 - 3,5	SW	▲
N105.SW35.35.01	25	5,5	13	0,05	1,0	3,5 - 4,0	SW	▲
N105.SW40.40.01	25	6,0	13	0,10	1,0	4,0 - 4,5	SW	▲
N105.SW45.45.01	25	7,0	13	0,10	1,0	4,5 - 5,0	SW	▲
N105.SW56.56.01	25	9,0	13	0,10	1,0	5,0 - 8,0	SW	▲
N105.SW80.80.01	30	12,0	18	0,10	1,0	8,0 - 10,0	SW+0,1	▲
N110.SW14.14.03	55	20,0	29	0,20	1,5	10,0 - 14,0	SW+0,1	▲
N110.SW16.16.04	55	25,0	29	0,20	2,0	14,0 - 16,5/ 16,8 - 18,0	SW+0,1/ SW+0,2	▲

▲ ab Lager / ab Lager Δ 4 Wochen / 4 Wochen x auf Anfrage / auf Anfrage

● empfohlen / empfohlen

o bedingt einsetzbar / bedingt einsetzbar

- nicht geeignet / nicht geeignet

■ unbeschichtete HM-Sorten / unbeschichtete HM-Sorten

■ beschichtete HM-Sorten / beschichtete HM-Sorten

■ bestückt/Cermet / bestückt/Cermet

Abmessungen in mm

Dimensions in mm

P	•
M	•
K	•
N	•
S	•
H	-

HM-Sorten
Carbide grades

Schneidplatte

Insert

N105

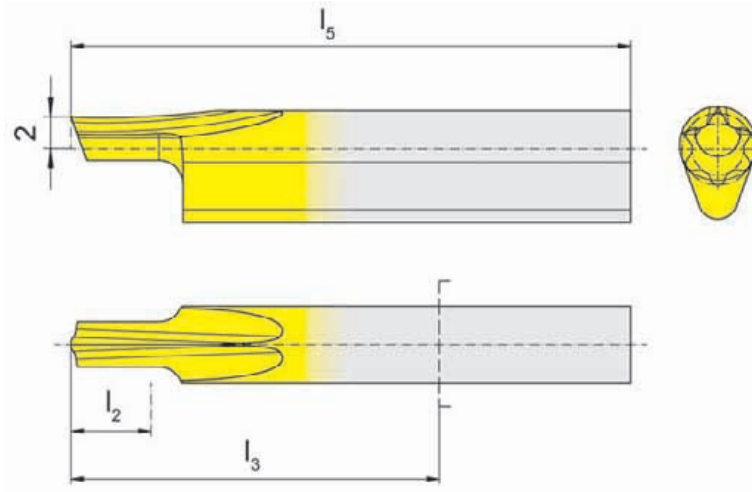
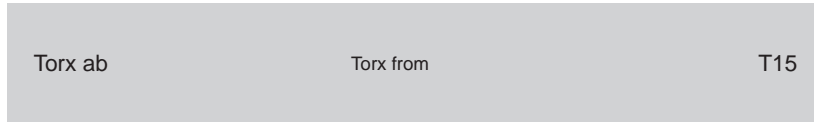
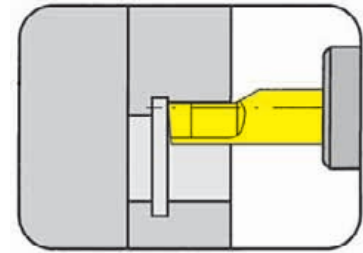

für Klemmhalter
for Toolholder

Typ SB105
Type B105

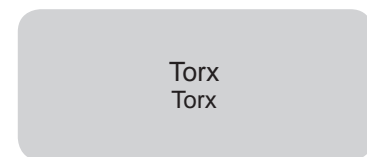

Bestellnummer Part number	Torx Torx	l_5	l_2	l_3	TA45
N105.TX15.24.03	T15	35	4	23	▲
N105.TX20.28.03	T20	35	4	23	▲
N105.TX25.32.03	T25	35	5	23	▲
N105.TX30.40.03	T30	35	5	23	△

▲ ab Lager / ab Lager △ 4 Wochen / 4 Wochen x auf Anfrage / auf Anfrage

● empfohlen / empfohlen

o bedingt einsetzbar / bedingt einsetzbar

- nicht geeignet / nicht geeignet

■ unbeschichtete HM-Sorten / unbeschichtete HM-Sorten

■ beschichtete HM-Sorten / beschichtete HM-Sorten

■ bestückt/Cermet / bestückt/Cermet

Abmessungen in mm

Dimensions in mm

P	•
M	•
K	•
N	•
S	•
H	-

HM-Sorten
Carbide grades



Typ SB105/SB110 - Halter zur Direktaufnahme in Revolver oder Spindel

type SB105/SB110 - Holder can be located directly in the turret or m/c spindle

Abmessungen DIN Dimensions DIN				Nutstoßen Broaching			Fasen Chamfering	
Breite Width	Toleranzklasse Tolerance grade	D _{min}	t	Nutstoßen Broaching			Fasen Chamfering	
				Schneidplatten Inserts	l ₂	Klemmhalter Toolholder	Schneidplatten Inserts	Klemmhalter Toolholder
2	C11	8	1,0	N105.0210.2.08	12			
3	C11	10	1,8	N105.0310.2.10	12	SB105.0020.1.01	N105.4545.2.6	SB105.0020.1.01 SB105.0025.1.01
3	C11	13	1,8	N105.0310.2.13	12	SB105.0025.1.01		
4	C11	16	2,0	N105.0410.2.16	12			
4	C11	16	2,0	N110.0410.05.04	25	SB110.0025.1.02	N110.4545.4.9	SB110.0025.1.02
4	C11	16	2,0	N110.0410.05.07	40	SB110.0032.1.02	N110.4545.7.9	SB110.0032.1.02
5	C11	-	-	N110.0510.05.04	25	SB110.0025.1.02	N110.4545.4.9	SB110.0025.1.02
5	C11	-	-	N110.0510.05.07	40	SB110.0032.1.02	N110.4545.7.9	SB110.0032.1.02
2	P9	6	1,1	N105.0198.01.01	12		N105.4545.2.6	SB105.0020.1.01
3	P9	8	1,5	N105.0298.01.01	12	SB105.0020.1.01		
4	P9	10	1,9	N105.0397.01.01	15	SB105.0025.1.01	N105.4545.3.6	SB105.0025.1.01
4	P9	10	1,9	N110.0397.02.04	25		N110.4545.4.9	
4	P9	10	1,9	N110.0397.02.07	40	SB110.0025.1.02	N110.4545.7.9	SB110.0025.1.02
5	P9	12	2,4	N110.0497.02.04	25	SB110.0032.1.02	N110.4545.4.9	SB110.0032.1.02
5	P9	12	2,4	N110.0497.02.07	40		N110.4545.7.9	
2	JS9	6	1,1	N105.0200.01.01	12		N105.4545.2.6	SB105.0020.1.01 SB105.0025.1.01
3	JS9	8	1,5	N105.0300.01.01	12	SB105.0020.1.01		
4	JS9	10	1,9	N105.0400.01.01	15	SB105.0025.1.01		
4	JS9	10	1,9	N105.0400.02.01	15			
4	JS9	10	1,9	N110.0400.02.04	25		N110.4545.4.9	
4	JS9	10	1,9	N110.0400.02.07	40	SB110.0025.1.02	N110.4545.7.9	SB110.0025.1.02
5	JS9	12	2,4	N110.0500.02.04	25	SB110.0032.1.02	N110.4545.4.9	SB110.0032.1.02
5	JS9	12	2,4	N110.0500.02.07	40		N110.4545.7.9	



Klemmhalter
Toolholder
SH117/H117/SH117

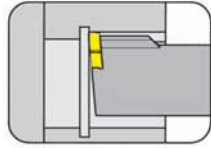

Seite/Page
V22-V30

Schneidplatte
Insert
S117

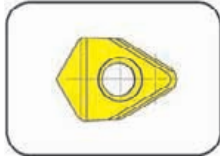

Seite/Page
V31-V35

S117



**Klemmhalter mit
Schneidplatten**

Bohrungs-Ø ab 14 mm

**Toolholder with
Inserts**

Bore Ø from 14 mm

V

Klemmhalter

Toolholder

SH117

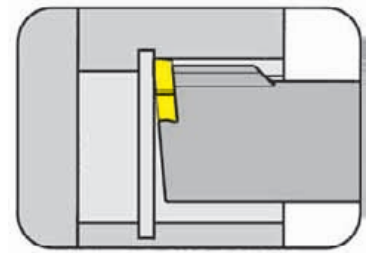

Bohrungs-Ø ab	Bore Ø from	14 mm
---------------	-------------	-------

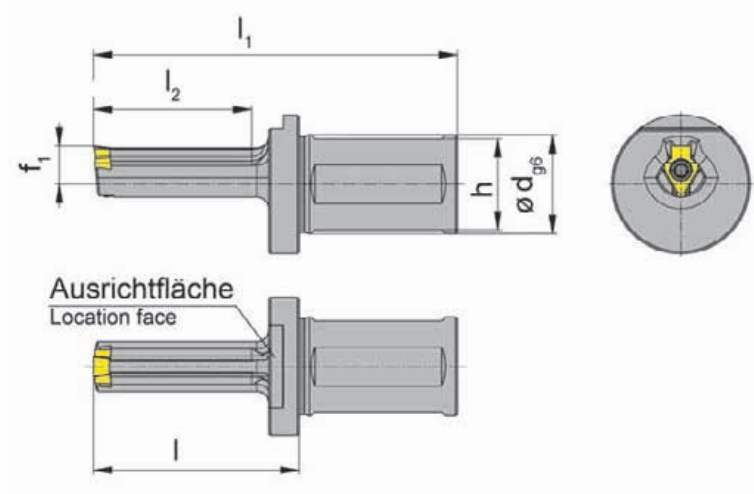

für Schneidplatte
for Insert

Typ S117
Type

Bestellnummer Part number	d	h	l	l ₁	l ₂	D _{min}	f ₁	Form Form
SH117.1425.1.3.08	25	23	32	72	20	14	9,6	G
SH117.1425.1.08	25	23	42	82	30	14	9,6	F
SH117.1425.2.08	25	23	52	92	40	14	9,6	F

Weitere Abmessungen auf Anfrage
Further sizes upon request

Abmessungen in mm
Dimensions in mm

Das Anzugsdrehmoment der Schrauben finden Sie in den Technischen Hinweisen.
For torque specification of the screw, please see Technical Instructions.

V

Ersatzteile

Spare Parts

Klemmhalter Toolholder	Schraube Screw	TORX PLUS®-Schlüssel TORX PLUS® Wrench
SH117...	030.3509.T15P	T15PQ

Klemmhalter

Toolholder

SHM117

mit innerer Kühlmittelzufuhr
with through coolant supply

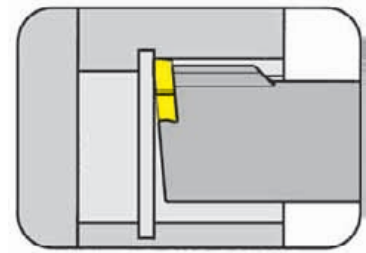

Bohrungs-Ø ab	Bore Ø from	14 mm
---------------	-------------	-------

Schaftmaterial: Hartmetall (schwingungsarm)
Material of shank: Carbide - Giving a good vibration resistance

für Schneidplatte
for Insert

Typ S117...08
Type

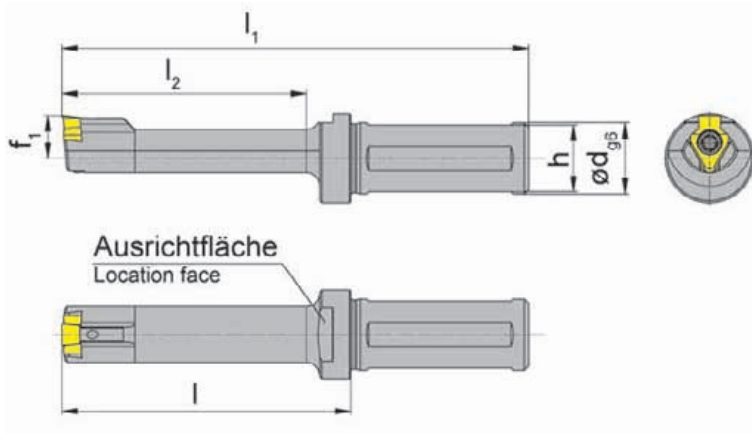

mit innerer
Kühlmittelzufuhr
with through coolant supply

Bestellnummer Part number	d	h	l	l ₁	l ₂	D _{min}	f ₁	Form Form
SHM117.1416.3.08	16	15	65	105	55	14	9,6	F

Weitere Abmessungen auf Anfrage
Further sizes upon request

Abmessungen in mm
Dimensions in mm

Das Anzugsdrehmoment der Schrauben finden Sie in den Technischen Hinweisen.
For torque specification of the screw, please see Technical Instructions.

Ersatzteile

Spare Parts

Klemmhalter Toolholder	Schraube Screw	TORX PLUS®-Schlüssel TORX PLUS® Wrench
SHM117.1416.3.08	030.3509.T15P	T15PQ

Klemmhalter

Toolholder

SH117

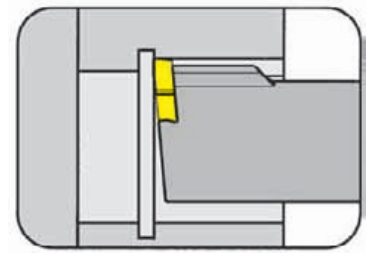

Bohrungs-Ø ab	Bore Ø from	17 mm
---------------	-------------	-------

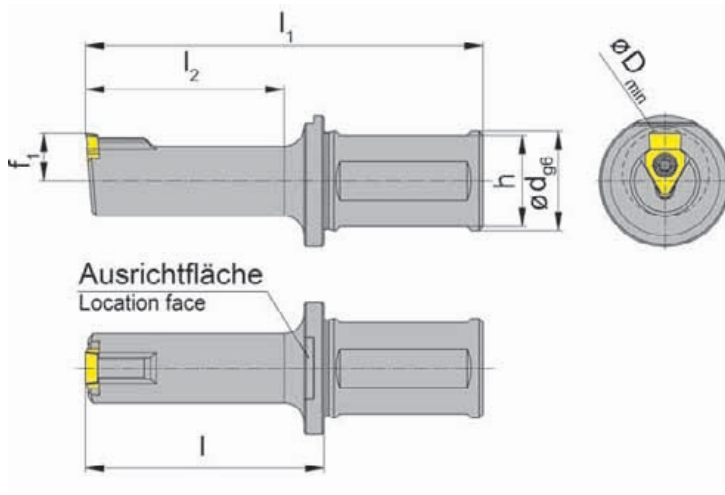

für Schneidplatte
for Insert

Typ S117
Type

Bestellnummer Part number	d	h	l	l ₁	l ₂	D _{min}	f ₁	Form Form
SH117.1725.1.10	25	23	50	90	40	17	9,5	A
SH117.1725.2.10	25	23	65	105	55	17	9,5	A
SH117.0025.1.10	25	23	60	100	50	22	12,0	B
SH117.0025.2.10	25	23	80	120	70	22	12,0	B
SH117.3032.1.16	32	30	60	100	50	30	16,5	C
SH117.3032.2.16	32	30	85	125	75	30	16,5	C
SH117.3032.3.16	32	30	110	170	100	30	16,5	C
SH117.0032.1.16	32	30	60	100	50	38	22,0	D
SH117.0032.2.16	32	30	85	125	75	38	22,0	D
SH117.0032.3.16	32	30	110	170	100	38	22,0	D
SH117.4032.1.16	32	30	62	122	50	40	21,5	E
SH117.4032.2.16	32	30	87	147	75	40	21,5	E
SH117.4032.3.16	32	30	112	172	100	40	21,5	E

Weitere Abmessungen auf Anfrage
Further sizes upon request

Abmessungen in mm
Dimensions in mm

Das Anzugsdrehmoment der Schrauben finden Sie in den Technischen Hinweisen.
For torque specification of the screw, please see Technical Instructions.

Ersatzteile

Spare Parts

Klemmhalter Toolholder	Spannschraube Screw	TORX PLUS®-Schlüssel TORX PLUS® Wrench
SH117...	4.09T15P	T15PQ
SH117...	5.12T20P	T20PQ

Klemmhalter

Toolholder

SH117

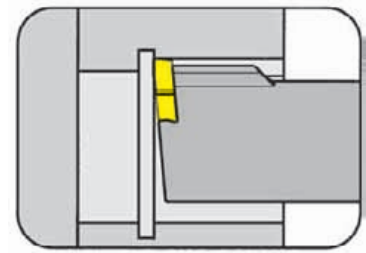

Bohrungs-Ø ab	Bore Ø from	14 mm
---------------	-------------	-------

nur für Nutstoßgeräte EWS-Slot und BENZ LinA
only usable for broaching devices EWS-Slot and BENZ LinA

für Schneidplatte
for Insert

Typ S117
Type

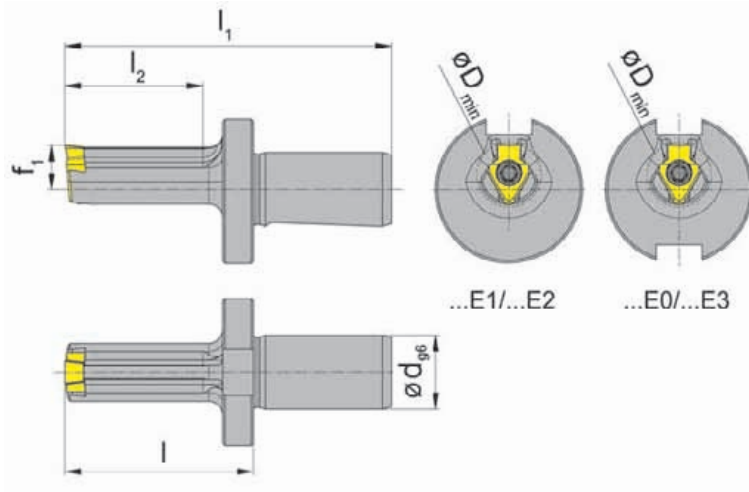

außen und innen
external and internal

Bestellnummer Part number	d	l	l ₁	l ₂	D _{min}	f ₁	Form Form	Maschinentyp Maschinentyp
SH117.1416.E1.08	16	41	71	30	14	9,6	F	BENZ / EWS
SH117.1716.E0.10	16	31	61	20	17	9,5	A	BENZ
SH117.1716.E1.10	16	41	71	30	17	9,5	A	BENZ / EWS
SH117.1716.E2.10	16	51	81	40	17	9,5	A	BENZ / EWS
SH117.1716.E3.10	16	64	94	53	17	9,5	A	BENZ
SH117.0016.E1.10	16	41	71	30	22	12,0	B	BENZ / EWS
SH117.0016.E2.10	16	51	81	40	22	12,0	B	BENZ / EWS
SH117.0016.E3.10	16	64	94	53	22	12,0	B	BENZ

Weitere Abmessungen auf Anfrage
Further sizes upon request

Abmessungen in mm
Dimensions in mm

Das Anzugsdrehmoment der Schrauben finden Sie in den Technischen Hinweisen.
For torque specification of the screw, please see Technical Instructions.

Ersatzteile

Spare Parts

Klemmhalter Toolholder	Schraube Screw	TORX PLUS®-Schlüssel TORX PLUS® Wrench	Spannschraube Screw
SH117.1416.E1.08	030.3509.T15P	T15PQ	
SH117...		T15PQ	4.09T15P

Klemmhalter

Toolholder

SH117/H117

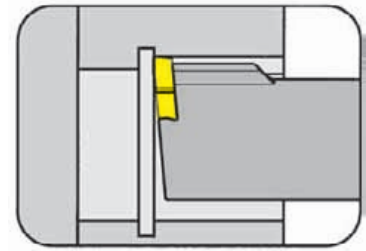

Bohrungs-Ø ab	Bore Ø from	14 mm
---------------	-------------	-------

für Nutstoßgerät Firma Schwarzer
for broaching device Schwarzer

für Schneidplatte
for Insert

Typ S117
Type

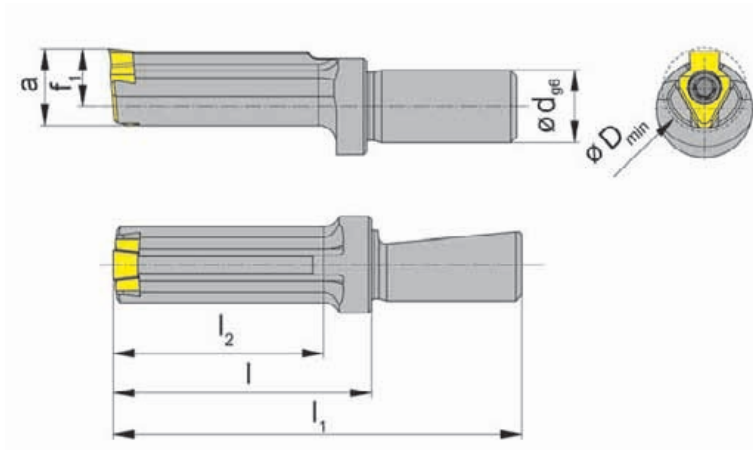

Bestellnummer Part number	d	l	l ₁	l ₂	D _{min}	f ₁	a	Form Form
SH117.1412.S1.08	12	33	58	25	14	9,6	12,80	F
SH117.1412.S2.08	12	43	68	35	14	9,6	12,80	F
H117.1712.1439	12	33	58	25	17	9,5	16,00	A
H117.1712.1407	12	43	68	35	17	9,5	16,00	A
H117.2212.1441	12	33	58	25	22	12,0	20,75	B
H117.2212.1442	12	43	68	35	22	12,0	20,75	B
H117.3012.1440	12	33	58	25	30	16,5	28,50	C
H117.3012.1419	12	43	68	35	30	16,5	28,50	C

Ausführungen für weitere Geräteschnittstellen auf Anfrage
Further sizes for other device interfaces upon request

Abmessungen in mm
Dimensions in mm

Das Anzugsdrehmoment der Schrauben finden Sie in den Technischen Hinweisen.
For torque specification of the screw, please see Technical Instructions.

Ersatzteile

Spare Parts

Klemmhalter Toolholder	Schraube Screw	TORX PLUS®-Schlüssel TORX PLUS® Wrench	Spannschraube Screw
SH117.1412....	030.3509.T15P	T15PQ	-
H117....1407/1439/1441/1442	-	T15PQ	4.09T15P
H117.3012.1...	-	T20PQ	5.12T20P

Klemmhalter

Toolholder

SH117

mit innerer Kühlmittelzufuhr
with through coolant supply

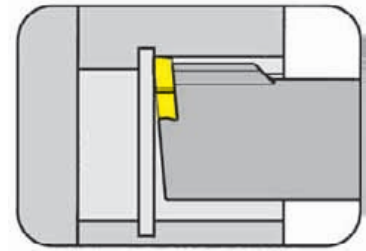

Bohrungs-Ø ab	Bore Ø from	14 mm
---------------	-------------	-------

für Nutstoßgerät Firma Schwarzer „2in1“
for broaching device Schwarzer „2in1“

für Schneidplatte
for Insert

Typ S117
Type

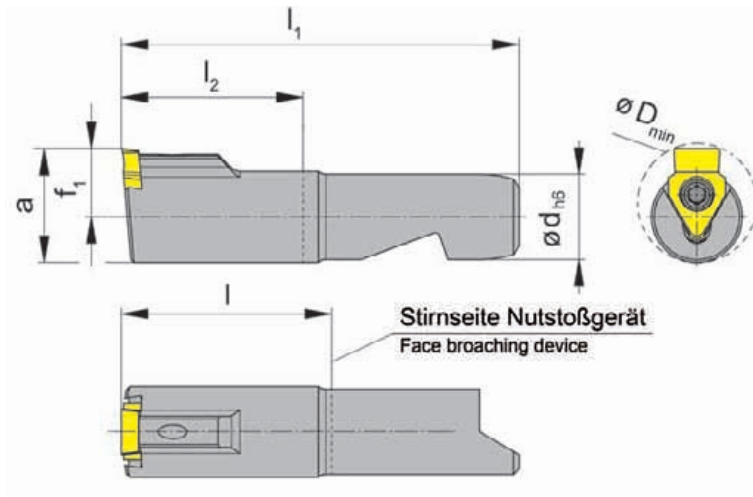

Bestellnummer Part number	d	l	l ₁	l ₂	D _{min}	f ₁	a	Form Form
SH117.0932.S.08	15	37	70	32	14	9,6	12,8	F
SH117.0932.S.10	15	37	70	32	17	9,5	16,0	A
SH117.1532.S.10	15	37	70	32	22	12,0	20,0	B
SH117.1538.S.16	15	43	76	38	30	15,0	24,0	C
SH117.1544.S.16	15	49	82	44	30	15,0	24,0	C

Ausführungen für weitere Geräteschnittstellen auf Anfrage
Further sizes for other device interfaces upon request

Abmessungen in mm
Dimensions in mm

Das Anzugsdrehmoment der Schrauben finden Sie in den Technischen Hinweisen.
For torque specification of the screw, please see Technical Instructions.

Ersatzteile

Spare Parts

Klemmhalter Toolholder	Schraube Screw	TORX PLUS®-Schlüssel TORX PLUS® Wrench	Spannschraube Screw
SH117.0932.S.08	030.3509.T15P	T15PQ	-
SH117...10	-	T15PQ	4.09T15P
SH117.15...16	-	T20PQ	5.12T20P

Klemmhalter

Toolholder

SH117

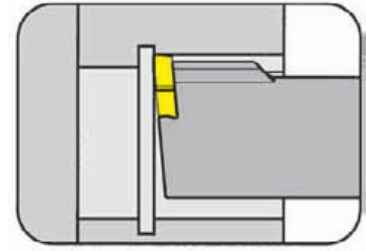

Bohrungs-Ø ab	Bore Ø from	22 mm
---------------	-------------	-------

für Nutstoßgerät AR2P
for broaching device AR2P

für Schneidplatte
for Insert

Typ S117
Type

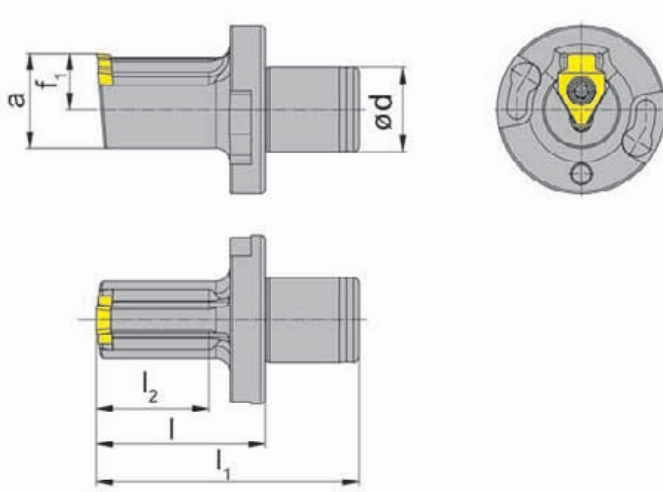

Bestellnummer Part number	d	l	l ₁	l ₂	D _{min}	f ₁	a	Form Form
SH117.2218.A1.10	18	36	56	24	22	12	20,25	B

Ausführungen für weitere Geräteschnittstellen auf Anfrage
Further sizes for other device interfaces upon request

Abmessungen in mm
Dimensions in mm

Das Anzugsdrehmoment der Schrauben finden Sie in den Technischen Hinweisen.
For torque specification of the screw, please see Technical Instructions.

V

Ersatzteile

Spare Parts

Klemmhalter Toolholder	Spannschraube Screw	TORX PLUS®-Schlüssel TORX PLUS® Wrench
SH117.2218.A1.10	4.09T15P	T15PQ

Klemmhalter

Toolholder

SH117

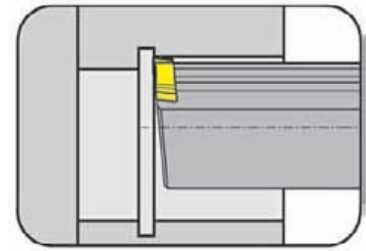

Bohrungs-Ø ab	Bore Ø from	17 mm
---------------	-------------	-------

für WTO Stoßeinheit
for broaching device WTO

für Schneidplatte
for Insert

Typ S117
Type

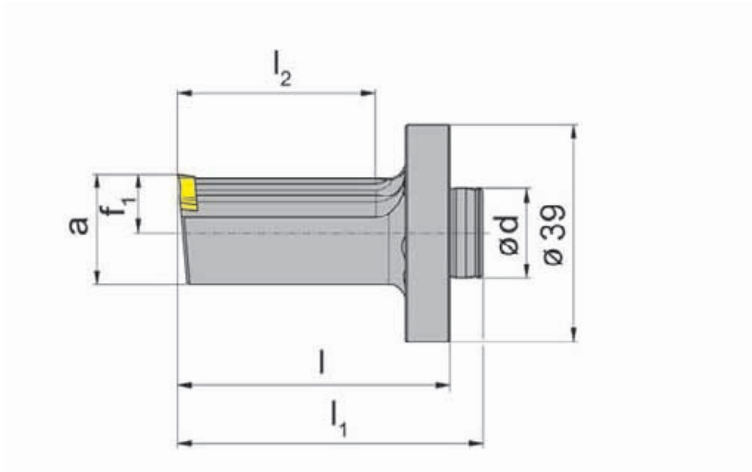

Bestellnummer Part number	d	l	l ₁	l ₂	D _{min}	f ₁	a	Form Form
SH117.1716.W1.10	16	49	55	35	17	8,3	15,1	A
SH117.2216.W1.10	16	49	55	35	22	10,6	19,8	B
SH117.2616.W1.16	16	49	55	35	26	12,6	23,5	C

Weitere Abmessungen auf Anfrage
Further sizes upon request

Abmessungen in mm
Dimensions in mm

Das Anzugsdrehmoment der Schrauben finden Sie in den Technischen Hinweisen.
For torque specification of the screw, please see Technical Instructions.

Ersatzteile

Spare Parts

Klemmhalter Toolholder	Spannschraube Screw	TORX PLUS®-Schlüssel TORX PLUS® Wrench
SH117...	4.09T15P	T15PQ
SH117.2616.W1.16	5.12T20P	T20PQ



Nutstoßen - Innensechskant

Broaching - Hexagon Socket



Klemmhalter

Toolholder

SH117

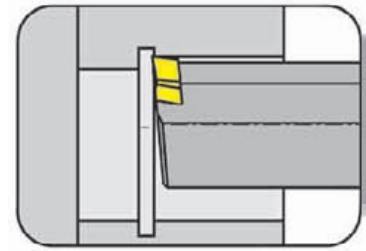

Bohrungs-Ø ab	Bore Ø from	14,2 mm
---------------	-------------	---------

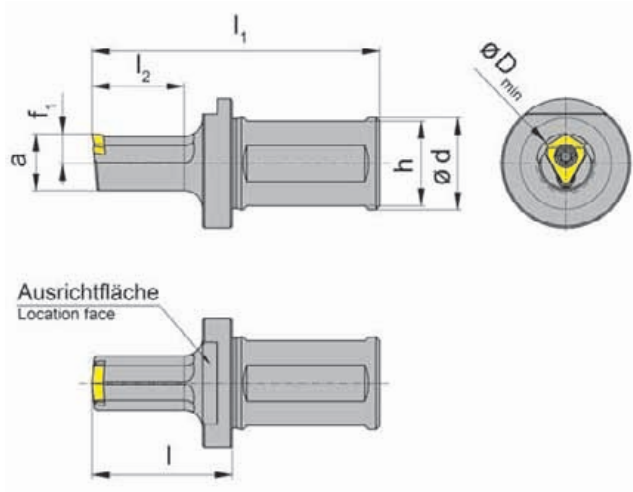

für Schneidplatte
for Insert

Typ S117
Type

Innensechskant
Hexagon socket

Bestellnummer Part number	d	h	l	l ₁	l ₂	D _{min}	f ₁	a	Schneidplatte Insert
SH117.1425.30.1.08	25	23	33	73	20	14,2	6,75	13	S117.SW14.08
SH117.1625.30.1.10	25	23	38	78	25	16,2	7,75	15	S117.SW16.10
SH117.2432.30.1.12	32	30	43	83	30	24,3	11,50	22	S117.SW24.12
SH117.3032.30.1.16	32	30	53	93	40	30,3	14,50	28	S117.SW30.16

Weitere Abmessungen auf Anfrage
Further sizes upon request

Abmessungen in mm
Dimensions in mm

Das Anzugsdrehmoment der Schrauben finden Sie in den Technischen Hinweisen.
For torque specification of the screw, please see Technical Instructions.

V

Ersatzteile

Spare Parts

Klemmhalter Toolholder	Schraube Screw	TORX PLUS®-Schlüssel TORX PLUS® Wrench	Spannschraube Screw
SH117.1425.30.1.08	030.3509.T15P	T15PQ	-
SH117...	-	T15PQ	4.09T15P
SH117.3032.30.1.16	-	T20PQ	5.12T20P

Schneidplatte

Insert

S117

Toleranzklasse C11
Tolerance grade C11

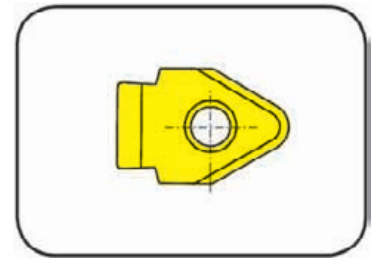

Bohrungs-Ø ab Nuttiefe bis	Bore Ø from Depth of groove up to	14 mm 8,5 mm
-------------------------------	--------------------------------------	-----------------

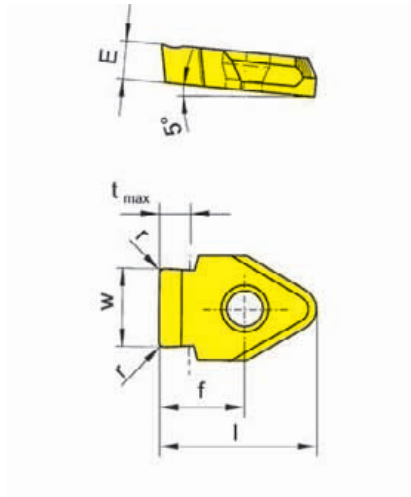

für Klemmhalter
for Toolholder

Typ SH117
Type SHM117
H117

Längsnuten nach DIN138
Keyways according to DIN138

Bestellnummer Part number	Nw	w	l	r	E	Form Form	D _{min}	t _{max}	f	TA45	TI25
S117.0310.04.08	3	3,10	13	0,35	4	G	14	2,0	6,0	▲	
S117.0410.05.08	4	4,12	13	0,50	4	F	14	2,1	6,0	▲	
S117.0610.22	6	6,12	16	0,85	3	B	22	2,6	8,0	▲	Δ
S117.0710.27	7	7,13	16	0,85	3	B	22	3,3	8,0	▲	Δ
S117.0810.32	8	8,13	16	1,05	3	B	22	3,4	8,0	▲	▲
S117.1014.40	10	10,13	21	1,05	6	C	30	4,2	11,2	▲	Δ
S117.1214.50	12	12,15	21	1,35	6	d	38	5,1	11,2	▲	Δ
S117.1614.70	16	12,15	21	1,75	6	d	38	6,6	11,2	Δ	
S117.2414.100	24	12,15	21	2,25	6	d	38	8,5	11,2	Δ	

▲ ab Lager / ab Lager Δ 4 Wochen / 4 Wochen x auf Anfrage / auf Anfrage

● empfohlen / empfohlen

o bedingt einsetzbar / bedingt einsetzbar

- nicht geeignet / nicht geeignet

■ unbeschichtete HM-Sorten / unbeschichtete HM-Sorten

■ beschichtete HM-Sorten / beschichtete HM-Sorten

■ bestückt/Cermet / bestückt/Cermet

Abmessungen in mm

Dimensions in mm

Hinweis:

Die Form der Schneidplatte muss der Halterform entsprechen. Bsp.: Klemmhalter Form A = Schneidplatte Form A

Note:

The insert form must correspond to the holder form. E.g.: Form A Toolholder = Form A Insert

Bestellhinweis:

Die Nutabmessungen nach DIN finden Sie auf Seite V36

Ordering note:

For Dimensions of Groove DIN please see page V36

P	●	●
M	●	●
K	●	●
N	●	●
S	●	●
H	-	-

HM-Sorten
Carbide grades



Schneidplatte

Insert

S117

Toleranzklasse P9
Tolerance grade P9

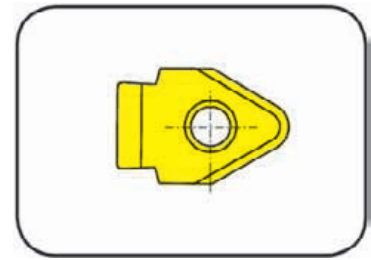

Bohrungs-Ø ab Nuttiefe bis	Bore Ø from Depth of groove up to	14 mm 6,8 mm
-------------------------------	--------------------------------------	-----------------

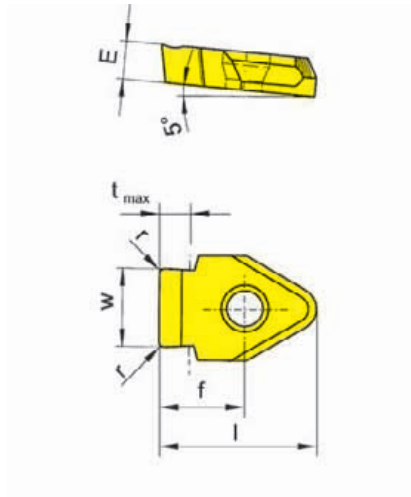

für Klemhalter
for Toolholder

Typ SH117
Type SHM117
H117

Längsnuten nach DIN6885
Keyways according to
DIN6885

Bestellnummer Part number	Nw	w	l	r	E	Form Form	D _{min}	t _{max}	f	TA45
S117.0298.01.08	3	2,99	13,0	0,12	4	G	14	2,0	6,0	▲
S117.0397.01.08	4	3,98	13,0	0,12	4	F	14	2,1	6,0	▲
S117.0497.02.08	5	4,98	13,0	0,20	4	F	14	2,7	6,0	▲
S117.0497.02.10	5	4,98	14,5	0,20	3	A	17	2,7	6,5	▲
S117.0597.02.10	6	5,98	14,5	0,20	3	A	17	3,4	6,5	▲
S117.0796.02.10	8	7,98	16,0	0,20	3	B	22	4,1	8,0	▲
S117.0996.03.14	10	9,98	21,0	0,30	6	C	30	4,2	11,2	▲
S117.1196.03.14	12	11,97	21,0	0,30	6	d	38	5,7	11,2	▲
S117.1396.03.16	14	13,97	21,0	0,30	6	E	40	6,8	11,2	▲

▲ ab Lager / ab Lager Δ 4 Wochen / 4 Wochen x auf Anfrage / auf Anfrage

● empfohlen / empfohlen

o bedingt einsetzbar / bedingt einsetzbar

- nicht geeignet / nicht geeignet

■ unbeschichtete HM-Sorten / unbeschichtete HM-Sorten

■ beschichtete HM-Sorten / beschichtete HM-Sorten

■ bestückt/Cermet / bestückt/Cermet

Abmessungen in mm

Dimensions in mm

Hinweis:

Die Form der Schneidplatte muss der Halterform entsprechen. Bsp.: Klemhalter Form A = Schneidplatte Form A

Note:

The insert form must correspond to the holder form. E.g.: Form A Toolholder = Form A Insert

Bestellhinweis:

Die Nutabmessungen nach DIN finden Sie auf Seite V36

Ordering note:

For Dimensions of Groove DIN please see page V36

P	•
M	•
K	•
N	•
S	•
H	-

HM-Sorten
Carbide grades

Schneidplatte

Insert

S117

Toleranzklasse JS9
Tolerance grade JS9

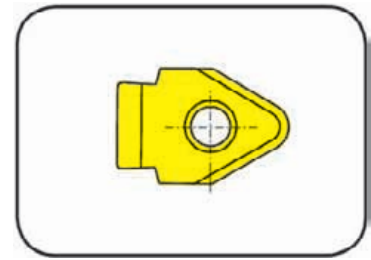

Bohrungs-Ø ab Nuttiefe bis	Bore Ø from Depth of groove up to	14 mm 8,5 mm
-------------------------------	--------------------------------------	-----------------

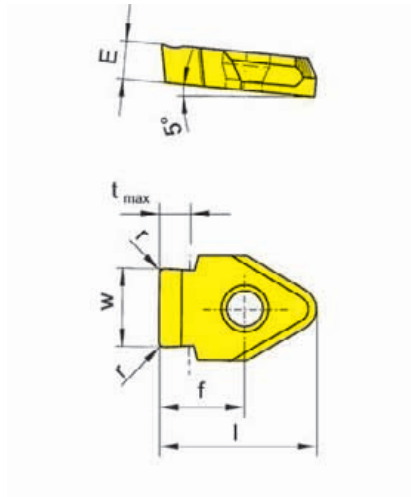

für Klemmhalter
for Toolholder

Typ SH117
Type SHM117
H117

Längsnuten nach DIN6885
Keyways according to
DIN6885

Bestellnummer Part number	Nw	w	l	r	E	Form Form	D _{min}	t _{max}	f	TA45
S117.0300.01.08	3	3,01	13,0	0,12	4	G	14	2,0	6,0	▲
S117.0400.01.08	4	4,01	13,0	0,12	4	F	14	2,1	6,0	▲
S117.0500.02.08	5	5,01	13,0	0,20	4	F	14	2,7	6,0	▲
S117.0500.02.10	5	5,01	14,5	0,20	3	A	17	2,7	6,5	▲
S117.0600.02.10	6	6,01	14,5	0,20	3	A	17	3,4	6,5	▲
S117.0800.02.10	8	8,01	16,0	0,20	3	B	22	4,1	8,0	▲
S117.1000.03.14	10	10,01	21,0	0,30	6	C	30	4,2	11,2	▲
S117.1200.05.14	12	12,00	21,0	0,50	6	d	38	8,5	11,2	▲
S117.1200.03.14	12	12,01	21,0	0,30	6	d	38	5,7	11,2	▲
S117.1400.03.16	14	14,01	21,0	0,30	6	E	40	6,8	11,2	▲

▲ ab Lager / ab Lager Δ 4 Wochen / 4 Wochen x auf Anfrage / auf Anfrage

● empfohlen / empfohlen

o bedingt einsetzbar / bedingt einsetzbar

- nicht geeignet / nicht geeignet

■ unbeschichtete HM-Sorten / unbeschichtete HM-Sorten

■ beschichtete HM-Sorten / beschichtete HM-Sorten

■ bestückt/Cermet / bestückt/Cermet

Abmessungen in mm

Dimensions in mm

Hinweis:

Schneidplatte S117.1200.05.14 ist Nw **ab** 12 mm!

Note:

Insert S117.1200.05.14 = Nw **from** 12 mm!

Die Form der Schneidplatte muss der Halterform entsprechen. Bsp.: Klemmhalter Form A = Schneidplatte Form A

The insert form must correspond to the holder form. E.g.: Form A Toolholder = Form A Insert

Bestellhinweis:

Die Nutabmessungen nach DIN finden Sie auf Seite V36

Ordering note:

For Dimensions of Groove DIN please see page V36

P	•
M	•
K	•
N	•
S	•
H	-

HM-Sorten
Carbide grades



Schneidplatte

Insert

S117

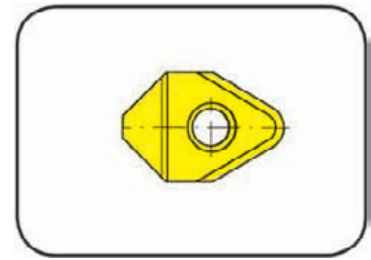

Bohrungs-Ø ab	Bore Ø from	14 mm
---------------	-------------	-------

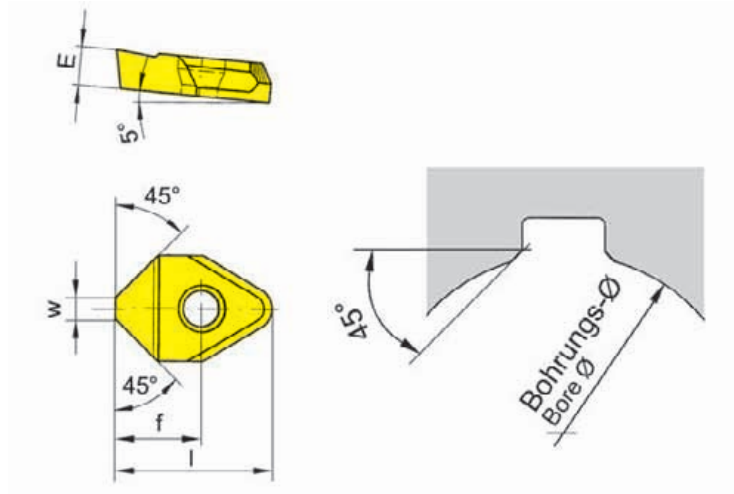

für Klemmhalter
for Toolholder

Typ SH117
Type SHM117
H117

Fasen
Chamfering

Bestellnummer Part number	w	l	E	Form Form	D _{min}	f	TA45
S117.2445.08	2,4	13	4	F	14	6,0	▲
S117.1545.10	1,5	16	3	A	17	8,0	▲
S117.3045.10	3,0	16	3	B	22	8,0	▲
S117.6045.14	6,0	21	6	C/D	30	11,2	▲

▲ ab Lager / ab Lager Δ 4 Wochen / 4 Wochen x auf Anfrage / auf Anfrage

● empfohlen / empfohlen

o bedingt einsetzbar / bedingt einsetzbar

- nicht geeignet / nicht geeignet

■ unbeschichtete HM-Sorten / unbeschichtete HM-Sorten

■ beschichtete HM-Sorten / beschichtete HM-Sorten

■ bestückt/Cermet / bestückt/Cermet

Abmessungen in mm

Dimensions in mm

Hinweis:

Die Form der Schneidplatte muss der Halterform entsprechen. Bsp.: Klemmhalter Form A = Schneidplatte Form A

Note:

The insert form must correspond to the holder form. E.g.: Form A Toolholder = Form A Insert

P	•
M	•
K	•
N	•
S	•
H	-

HM-Sorten
Carbide grades

Nutstoßen - Innensechskant

Broaching - Hexagon Socket



Schneidplatte

Insert

S117

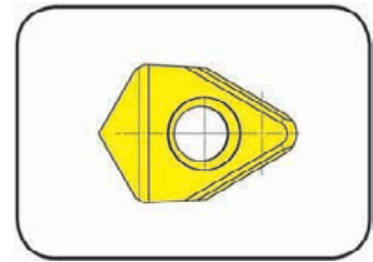

Innensechskant ab Hexagon socket from SW14 - SW36

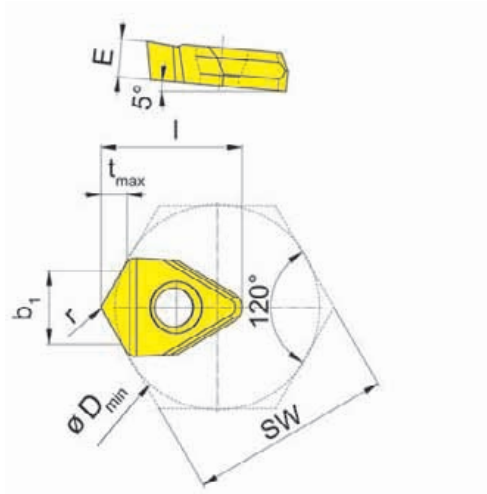

für Klemmhalter
for Toolholder

Typ SH117
Type SHM117

Innensechskant
Hexagon socket

Bestellnummer Part number	SW	b ₁	l	r	E	D _{min}	t _{max}	Klemmhalter Toolholder	Ti25
S117.SW14.08	14-16	4,94-5,80	13,0	0,2	4,0	14,2-16,2	1,9	SH117.1425.30.1.08	▲
S117.SW16.10	16-22	5,80-8,43	14,0	0,2	3,0	16,2-22,2	2,5	SH117.1625.30.1.10	▲
S117.SW24.12	24-27	8,70-10,00	17,0	0,3	4,5	24,3-27,3	3,0	SH117.2432.30.1.12	▲
S117.SW30.16	30-36	11,32-13,97	20,7	0,3	6,0	30,3-36,3	4,2	SH117.3032.30.1.16	▲

▲ ab Lager / on stock Δ 4 Wochen / 4 weeks x auf Anfrage / upon request

● empfohlen / recommended

o bedingt einsetzbar / alternative recommendation

- nicht geeignet / not suitable

■ unbeschichtete HM-Sorten / uncoated grades

■ beschichtete HM-Sorten / coated grades

■ bestückt/Cermet / brazed/Cermet

Abmessungen in mm

Dimensions in mm

P	•
M	•
K	•
N	•
S	•
H	-

HM-Sorten
Carbide grades



Typ SH117 / SHM117 - Halter zur Direktaufnahme in Revolver oder Spindel
 type SH117 / SHM117 - Holder can be located directly in the turret or m/c spindle

Abmessungen DIN Dimensions DIN				Nutmüssen Broaching		Fasen Chamfering				
Breite Width	Toleranzklasse Tolerance grade	D _{min}	t	Schneidplatten Inserts	W	Klemmhalter Toolholder	Werkzeuglänge l ₁ Tool length l ₁	Schneidplatten Inserts	Klemmhalter Toolholder	Werkzeuglänge l ₂ Tool length l ₂
3		14	2,0	S117.0310.04.08	3,1	SH117.1425.1.3.08	.1.	S117.2445.08	SH/SHM117...08	.1.
4		14	2,1	S117.0410.05.08	4,12	SH/SHM117...08	.2.	S117.2445.08	SH/SHM117...08	.2.
6		22	2,6	S117.0610.22	6,12	SH117.0025...10	.3.	S117.3045.10	SH117.0025...10	.3.
7		27	3,3	S117.0710.27	7,13	SH117.0025...10		S117.3045.10	SH117.0025...10	
8	C11	32	3,4	S117.0810.32	8,13	SH117.0025...10		S117.3045.10	SH117.0025...10	
10		40	4,2	S117.1014.40	10,13	SH117.0032...16		S117.6045.14	SH117.0032...16	
12		50	5,1	S117.1214.50	12,15	SH117.0032...16		S117.6045.14	SH117.0032...16	
16		70	6,6	S117.1614.70	12,15	SH117.0032...16		S117.6045.14	SH117.0032...16	
24		100	8,5	S117.2414.100	12,15	SH117.0032...16		S117.6045.14	SH117.0032...16	
3		14	2,0	S117.0298.01.08	2,99	SH117.1425.1.3.08	20	S117.2445.08	SH/SHM117...08	20/30
4		14	2,1	S117.0397.01.08	3,98	SH/SHM117...08	30	S117.2445.08	SH/SHM117...08	20/30
5		14	2,7	S117.0497.02.08	4,98	SH/SHM117...08	40	S117.2445.08	SH/SHM117...08	20/30
5		14	2,7	S117.0497.02.08	4,98	SH117.1725...10	55	S117.1545.10	SH117.1725...10	55
5	P9	17	2,7	S117.0497.02.10	4,98	SH117.1725...10	40	S117.1545.10	SH117.1725...10	40
6		17	3,4	S117.0597.02.10	5,98	SH117.1725...10	55	S117.1545.10	SH117.1725...10	55
8		22	4,1	S117.0796.02.10	7,98	SH117.0025...10	70	S117.3045.10	SH117.0025...10	70
10		30	4,2	S117.0996.03.14	9,98	SH117.3032...16	100	S117.6045.14	SH117.3032...16	100
12		38	5,7	S117.1196.03.14	11,97	SH117.0032...16	100	S117.6045.14	SH117.0032...16	100
14		40	6,8	S117.1396.03.16	13,97	SH117.4032...16	50	S117.6045.14	SH117.0032...16	50
3		14	2,0	S117.0300.01.08	3,01	SH117.1425.1.3.08	20	S117.2445.08	SH/SHM117...08	20/30
3		14	2,1	S117.0400.01.08	4,01	SH/SHM117...08	40	S117.2445.08	SH/SHM117...08	20/30
5		14	2,7	S117.0500.02.08	5,01	SH/SHM117...08	30	S117.2445.08	SH/SHM117...08	20/30
5		17	2,7	S117.0500.02.10	5,01	SH117.1725...10	40	S117.1545.10	SH117.1725...10	40
6		17	3,4	S117.0600.02.10	6,01	SH117.1725...10	55	S117.1545.10	SH117.1725...10	55
8	JS9	22	4,1	S117.0800.02.10	8,01	SH117.0025...10	70	S117.3045.10	SH117.0025...10	70
10		30	4,2	S117.1000.03.14	10,01	SH117.3032...16	100	S117.6045.14	SH117.3032...16	100
12		38	5,7	S117.1200.03.14	12,01	SH117.0032...16	100	S117.6045.14	SH117.0032...16	100
12		38	8,5	S117.1200.05.14	12,00	SH117.0032...16	100	S117.6045.14	SH117.0032...16	100
14		40	6,8	S117.1400.03.16	14,01	SH117.4032...16	50	S117.6045.14	SH117.0032...16	50

Tipps und Tricks

- Am Nutende einer Sackbohrung muss eine Stoßauslaufnut oder ein Freistich vorhanden sein.
- Heben Sie das Werkzeug beim Rückhub an.
- Eine Kühlmittelzufuhr von Emulsionen oder Öl in der Bohrung, ist von entscheidendem Vorteil. Hierdurch werden die Späne aus der Bohrung gespült. Auch der Schmiereffekt des Kühlmediums hat sich bei fast allen Anwendungen positiv auf die Oberflächenbeschaffenheit der Nut und die Standzeit ausgewirkt.
- Wenn möglich sollte oben (Position 12 Uhr) gestoßen werden, damit der Stoßzyklus nicht durch anfallende Späne beeinträchtigt wird.
- Vorsicht bei beengten Bohrungen! Kollisionsgefahr am Rücken!
- Messen Sie das Werkzeug korrekt aus. Beachten Sie das Anstellmaß beim Programmieren des ersten Hubes.

Application Tips:

- It is important to use a machine with mechanical spindle lock.
- The use of proper coolant is key to a good surface finish, long tool life as well as chip evacuation.
- A relief groove or the possibility for a "ramp down" exit out of the cut is necessary at the end of the broached groove.
- Setting of the tool is very important. Double check the component diameter before taking the first pass.
- The tool should be set at the 12 o'clock position to ensure that chips fall away from the groove.
- Take an accurate measurement of the insert and program the dimension into the machine tool parameter.
- Position the tool at the start position of the first stroke and program a stop to perform a visual check to assure a collision free first pass of the tool.

Bearbeitungsbeispiel:

Bohrungs-Ø 32 mm, Nutbreite 8 mm:
 Bei einem Bohrungsradius von 16 mm und einer Sicherheit von 0,2 mm an den Eckradien der Schneidplatte muss das Werkzeug in der X-Achse auf Anstellmaß 15,292 mm (bzw. X 30,584) eingestellt werden, um einen kollisionsfreien Hub zu gewährleisten.

Machining example:

Bore diameter 32 mm, groove width 8 mm:
 At a radius of 16 mm and with a clearance of 0,2 mm for safety at the r 0,2 mm corner radii, the tool has to be set at 15,292 mm in X-axis to avoid any collision at the beginning of the process.

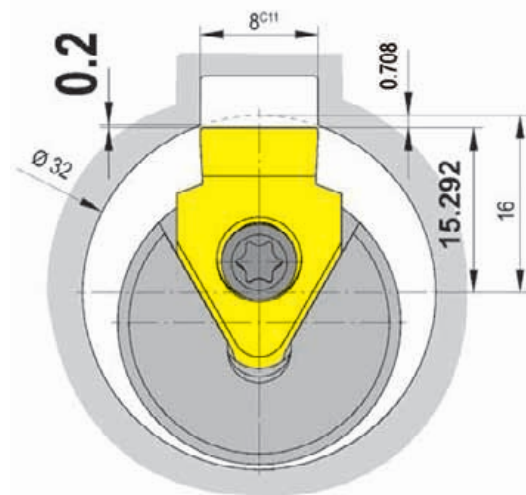

Berechnung Anstellmaß b_1 :

Calculation of the start position b_1 :

$$c^2 = a^2 + b^2$$

$$b^2 = c^2 - a^2$$

$$b = \sqrt{c^2 - a^2}$$

$$b = \sqrt{16^2 - 4^2}$$

$$b = 15,491933$$

$b_1 = b - \text{Sicherheitsabstand}$
 Clearance distance

$$b_1 = 15,492 - 0,2 = 15,292 \text{ mm}$$

→ ergibt einen Anstell-Ø von 30,584 mm

→ equals as a start position at Ø 30.584 mm

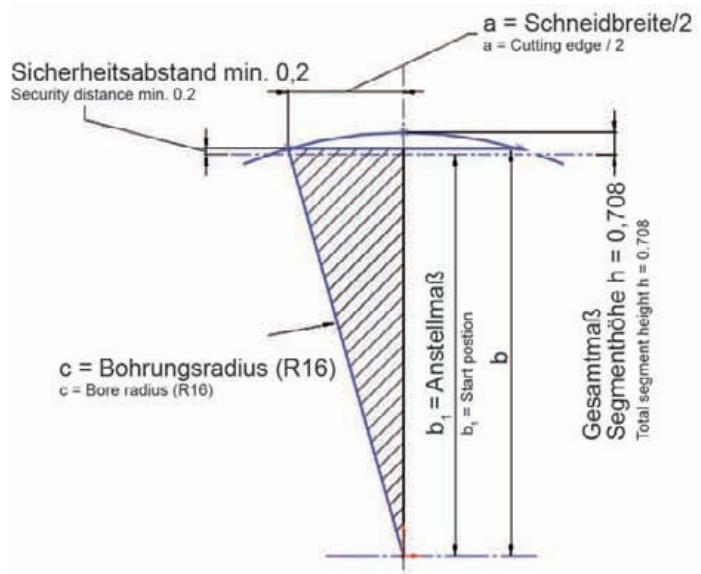

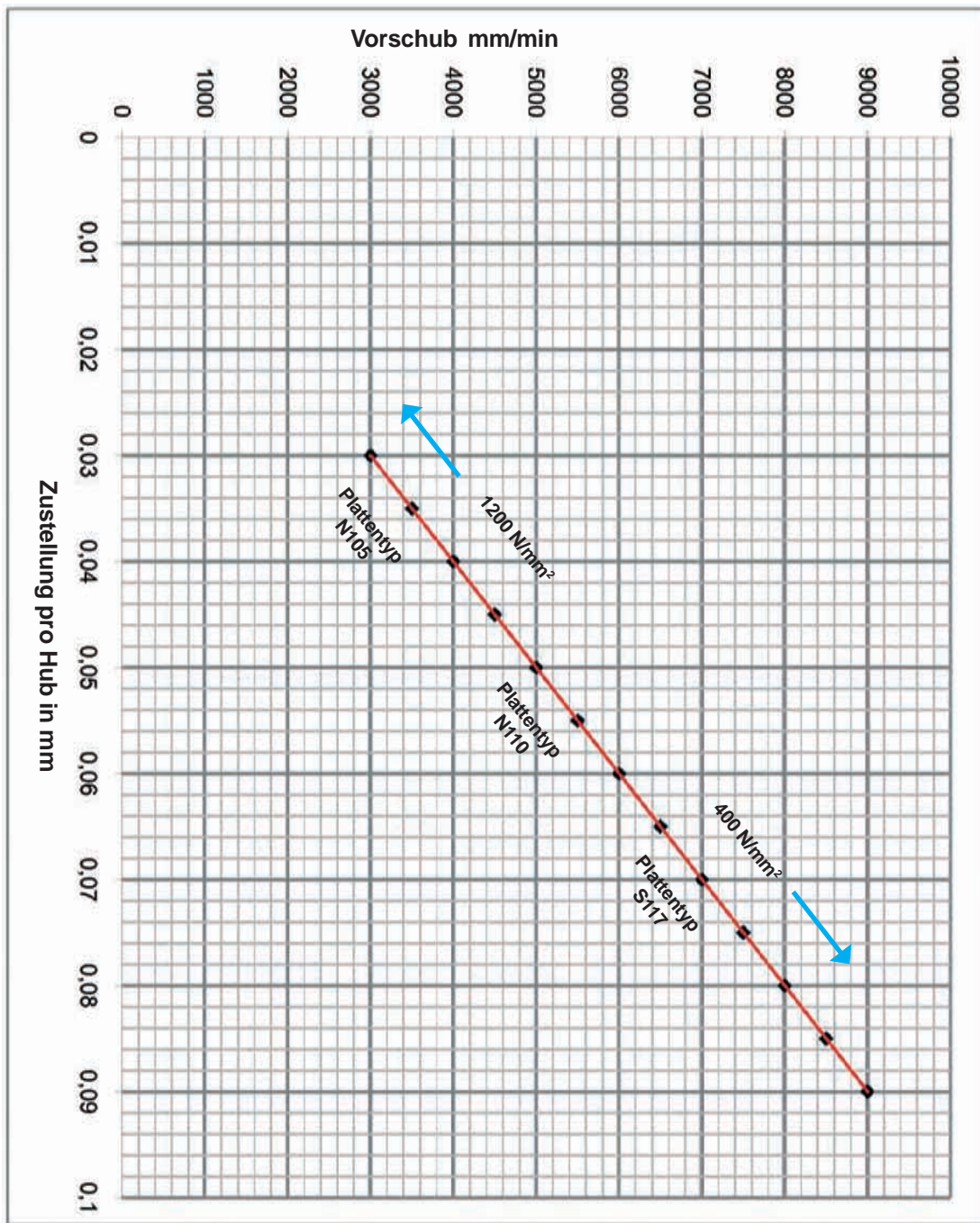

Diese Werte stellen nur Richtwerte dar, da die physikalischen Eigenschaften der Maschine, des Bauteils, die Spannsituation und der Werkstoff großen Einfluss auf die Schnittwerte und Zustellungen pro Hub nehmen.

Anwendungstipps:

- Am Nutende einer Sacklochbohrung muss eine Auslaufnut oder ein Freistich vorhanden sein.
- Das Werkzeug muss vor dem Rückzug vollständig aus dem Nutenbereich gefahren werden.
- Messen Sie das Werkzeug korrekt aus, und übernehmen diese Werte in Ihren Werkzeugspeicher.
- Fahren Sie den ersten Anstellpunkt der Maschine im Einzelsatz an und überprüfen Sie durch einen Programmstopp, - visuell -, ob die Anstellposition für den ersten Hub kollisionsfrei für den Werkzeughalter und die Schneide ist.
- Der Einsatz eines Kühl - u. Schmiermedium ist entscheidend für die Oberflächenbeschaffenheit, der Standzeit und der Ausspülung der Späne aus der Sacklochbohrung.

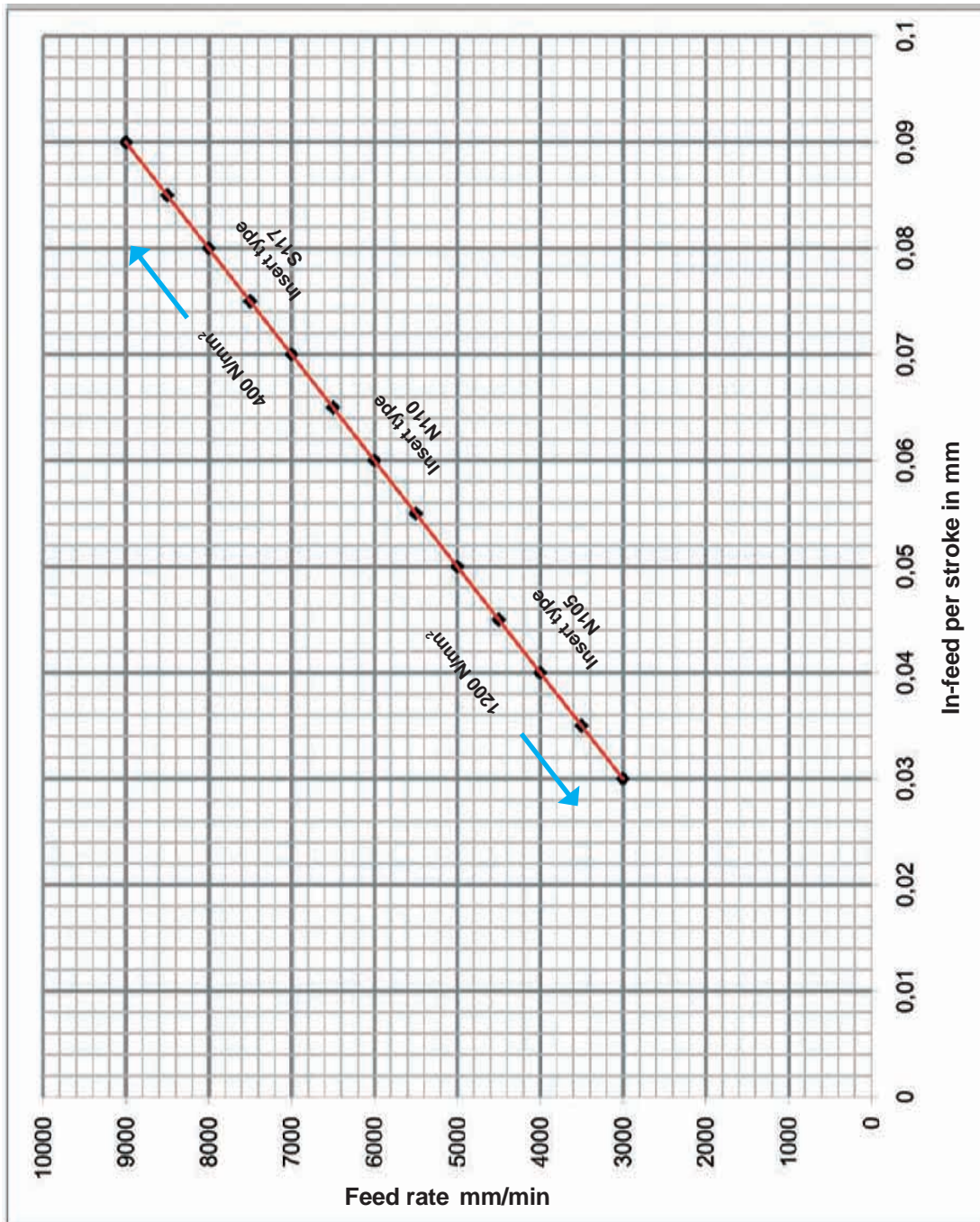

The above values are guidelines only. The physical condition of the machine, the work piece profile and clamping, as well as the type of material have great influence on the depth of cut and feed rate.

Application Tips:

- A relief groove or the possibility for a 'ramp down' exit out of the groove is necessary at the end of the broached groove.
- The insert cutting edge has to be positioned outside the groove before retracting the tool.
- Take an accurate measurement of the insert and program the dimension into the machine tool parameter.
- Position the tool at the start position of the first stroke and program a stop to perform a visual check to assure a collision free first pass of the tool.
- The use of proper coolant is key to a good surface finish, long tool life as well as chip evacuation out of a blind hole.

Beispiel zum Nutstoßen auf TRAUB TNA 400 mit C - Achse

NC - Programm

N.....(NUTSTOSSEN)	Satznummer, (Klammertext)
G97 T..... M5	Konstante Spindeldrehzahl, Werkzeugaufruf, Spindel STOP
M17	C - Achse EIN
G94	Vorschub in mm/min
L1 = 30.584	Parameter für Start Ø gesetzt
M8 M19	Kühlmittel EIN, Spindelbremse EIN
N100	Satznummer der Wiederholschleife Anfang
G0 XL1 Z5	Anstellpunkt in X und Z vor dem Teil
G1 Z-25 F8000	Lineare Vorschubbewegung in Z mit Vorschub 8000 mm/min
G0 X30.584	Eilgangbewegung in X auf Anstellpunkt Ø = Abhebe punkt
G0 Z5	Eilgangbewegung auf Anstellpunkt Z
L1 = L1+0.16	Zähler hochzählen mit doppelter Zustellsumme, da Ø Programmierung angewählt ist (Zustellwert beträgt 0,08 mm)
N200	Satznummer der Wiederholschleife Ende
G22 P100 Q200 H45	Wiederholzyklus mit Satznummer von Start und Ende und Anzahl der Wiederholschleifen

Beispiel:

- Nut nach Tabelle mit Bohrung $\varnothing 32 \text{ mm}$
- Nutbreite 8^{c11}
- Zustellsumme pro Hub 0,08 mm
- Die Anzahl der **Hübe** errechnet sich von dem Abstand ab Startpunkt bis Nutgrund und wird dann über den Wert der Zustellung pro Hub (nach Tabelle) geteilt.
- Dieser Wert muss dann mit 2 multipliziert werden (da Ø-Programmierung), dies ist dann der zu programmierende Wert der Hübe im NC-Programm.

Berechnung:

- Anstellpunkt = Sicherheitsabstand + Maß der Bogenhöhe vom Kreis $\varnothing 32$ (siehe Berechnungsbeispiel Seite V37) ergibt eine Segmenthöhe von **0,508 mm** + Sicherheitsabstand von **0,2 mm** ein Gesamtmaß von **0,708 mm**.
 - Anstellpunkt = **30,584 mm** ($32 - [0,708 \times 2] = 30,584$)
 - Die Nuttiefe **2,9 mm** mit dem Maß **0,708 mm** addiert ergibt den Wert **3,608 mm**.
 - Dieser Wert ist die Strecke von Anstellpunkt bis Nutgrund, um dies Ø-bezogen zum Programmieren, wird der Wert **3,608 mit 2 multipliziert** und gibt die Summe **7,216 mm**.
 - Teilt man **7,216 mm** mit dem doppelten Wert von **0,08 mm also 0,16 mm** Hubzustellung errechnet sich eine Gesamt-Hubanzahl von **45,1** Hüben. Also werden **45 Hübe** programmiert.
- Die Restsumme muss in der Feinkorrektur auf das Zeichnungsmaß gebracht werden.

Achtung: Die tatsächliche Zustellung auf die Stoßplatte beträgt 0,08 mm.

Example for broaching on a TRAUB TNA 400 with C-Axis

NC - Programme

N.....(BROACHING)	Sequence Number and Application
G97 T..... M5	constant RPM, Tool callout, Spindle Stop
M17	C - axis ON
G94	Feed Rate in mm/min
L1 = 30.584	choose Parameter for start Ø
M8 M19	Coolant ON, Spindle Break ON
N100	Sequence Number for repetition START
G0 XL1 Z5	Start position in X and Z in front of part
G1 Z-25 F8000	Linear move in Z at feed rate of 8000 mm/min
G0 X30.584	Rapid move in X to start Ø i.e. drop down position
G0 Z5	Rapid move in Z to start position.
L1 = L1+0.16	As Ø programming is in effect the depth of cut must be doubled (Depth of Cut is 0.08 mm)
N200	Sequence Number of repetition END.
G22 P100 Q200 H45	Repetition Cycle with Sequence Number from START to END and Number of repetitions

Example:

- Groove according to table in bore **Ø 32 mm**
- Groove width **8^{c11}**
- Depth of Cut per Stroke 0.08 mm
- The **Number of Strokes** resulted out of complete cutting depth from start position to the bottom of the groove divided by depth of cut per stroke
- This Value must then be multiplied by 2 (because Ø Programming) and Value is programmed as the Number of Strokes in the NC-Programme.

Calculation:

- Starting Position = Security Distance + Distance from Ø 32 mm to Cutting Edge (see Example on Page V37) equals a segment height of **0.508 mm** + Security Distance of **0.20 mm** to a total of **0.708 mm**.
- Starting Position = **30.584 mm** (32 - [0.708 x 2] = 30.584 mm.
- The groove depth of **2.90 mm** added to the **0.708 mm** = **3.608 mm**.
- This is the dimension from the starting position to the bottom of the groove and in order to program this on the Ø, the **3.608 mm** dimension must be **multiplied by 2** which will equal the sum of **7.216 mm**.
- When the **7.216 mm** is divided by (**2 x 0.08 mm**) = **0.16 mm** depth per stroke the Result will be **45.1 Strokes** and therefore **45 total Strokes** are programmed.

The remainder of 0.1 Strokes to achieve the finish dimension must be programmed using the fine correction.

Attention: The true depth of cut for the insert will be 0.08 mm.

Beispiel zum Nutstoßen auf Maschinen mit SIEMENS-Steuerung und geklemmter Spindel

NC - Programm

N.....LF (NUTSTOSSEN)	Satznummer, (Klammertext)
T..... M5 LF	Werkzeugaufruf, Spindel STOP
M..... LF	Bremse EIN
G94 LF	Vorschub in mm/min
R1 = 30.584 LF	Parameter für Start Ø gesetzt
M8 LF	Kühlmittel EIN
N100 LF	Satznummer der Wiederholschleife Anfang
G0 XR1 Z5 LF	Anstellpunkt in X und Z vor dem Teil
G1 Z-25 F8000 LF	Lineare Vorschubbewegung in Z mit Vorschub 8000 mm/min
G0 X30.584	Eilgangbewegung in X auf Anstellpunkt Ø = Abhebepunkt
G0 Z5	Eilgangbewegung auf Anstellpunkt Z
R1 = R1+0.16	Zähler hochzählen mit doppelter Zustellsumme, da Ø Programmierung angewählt ist (Zustellwert beträgt 0,08 mm)
N200	Satznummer der Wiederholschleife Ende
.....LF	Wiederholzyklus mit Satznummer von Start und Ende und Anzahl der Wiederholschleifen

Beispiel:

- Nut nach Tabelle mit Bohrung **Ø 32 mm**
- Nutbreite **8^{c11}**
- Zustellsumme pro Hub **0,08 mm**
- Die Anzahl der **Hübe** errechnet sich von dem Abstand ab Startpunkt bis Nutgrund und wird dann über den Wert der Zustellung pro Hub (nach Tabelle) geteilt.
- Dieser Wert muss dann mit 2 multipliziert werden (da Ø-Programmierung), dies ist dann der zu programmierende Wert der Hübe im NC-Programm.

Berechnung:

- Anstellpunkt = Sicherheitsabstand + Maß der Bogenhöhe vom Kreis Ø 32 (siehe Berechnungsbeispiel Seite V37) ergibt eine Segmenthöhe von **0,508 mm** + Sicherheitsabstand von **0,2 mm** ein Gesamtmaß von **0,708 mm**.
 - Anstellpunkt = **30,584 mm** ($32 - [0,708 \times 2] = 30,584$)
 - Die Nuttiefe **2,9 mm** mit dem Maß **0,708 mm** addiert ergibt den Wert **3,608 mm**.
 - Dieser Wert ist die Strecke von Anstellpunkt bis Nutgrund, um dies Ø-bezogen zum Programmieren, wird der Wert **3,608 mit 2 multipliziert** und gibt die Summe **7,216 mm**.
 - Teilt man **7,216 mm** mit dem doppelten Wert von **0,08 mm also 0,16 mm** Hubzustellung errechnet sich eine Gesamt-Hubanzahl von **45,1** Hüben. Also werden **45 Hübe** programmiert.
- Die Restsumme muss in der Feinkorrektur auf das Zeichnungsmaß gebracht werden.

Example for broaching on SIEMENS Control Machines with lockable Spindle

NC - Programme

N.....(BROACHING)	Sequence Number and Application
T..... M5 LF	Tool callout, Spindle Stop
M..... LF	Brake ON
G94 LF	Feed Rate in mm/min
R1 = 30.584 LF	choose Parameter for start Ø
M8 LF	Coolant ON
N100 LF	Sequence Number for repetition START
G0 XR1 Z5 LF	Start position in X and Z in front of part
G1 Z-25 F8000 LF	Linear move in Z at feed rate of 8000 mm/min
G0 X30.584	Rapid move in X to start Ø i.e. drop down position
G0 Z5	Rapid move in Z to start position.
R1 = R1+0.16	As Ø programming is in effect the depth of cut must be doubled (Depth of Cut is 0.08 mm)
N200	Sequence Number of repetition END.
.....LF	Repetition Cycle with Sequence Number from START to END and Number of repetitions

Example:

- Groove according to table in bore **Ø 32 mm**
- Groove width **8^{c11}**
- Depth of Cut per Stroke 0.08 mm
- The **Number of Strokes** resulted out of complete cutting depth from start position to the bottom of the groove divided by depth of cut per stroke
- This Value must then be multiplied by 2 (because Ø Programming) and Value is programmed as the Number of Strokes in the NC-Programme.

Calculation:

- Starting Position = Security Distance + Distance from Ø 32 mm to Cutting Edge (see Example on Page V37) equals a segment height of **0.508 mm** + Security Distance of **0.20 mm** to a total of **0.708 mm**.
- Starting Position = **30.584 mm** (32 - [0.708 x 2] = 30.584 mm.
- The groove depth of **2.90 mm** added to the **0.708 mm** = **3.608 mm**.
- This is the dimension from the starting position to the bottom of the groove and in order to program this on the Ø, the **3.608 mm** dimension must be **multiplied by 2** which will equal the sum of **7.216 mm**.
- When the **7.216 mm** is divided by (**2 x 0.08 mm**) = **0.16 mm** depth per stroke the Result will be **45.1 Strokes** and therefore **45 total Strokes** are programmed.

The remainder of 0.1 Strokes to achieve the finish dimension must be programmed using the fine correction.





V

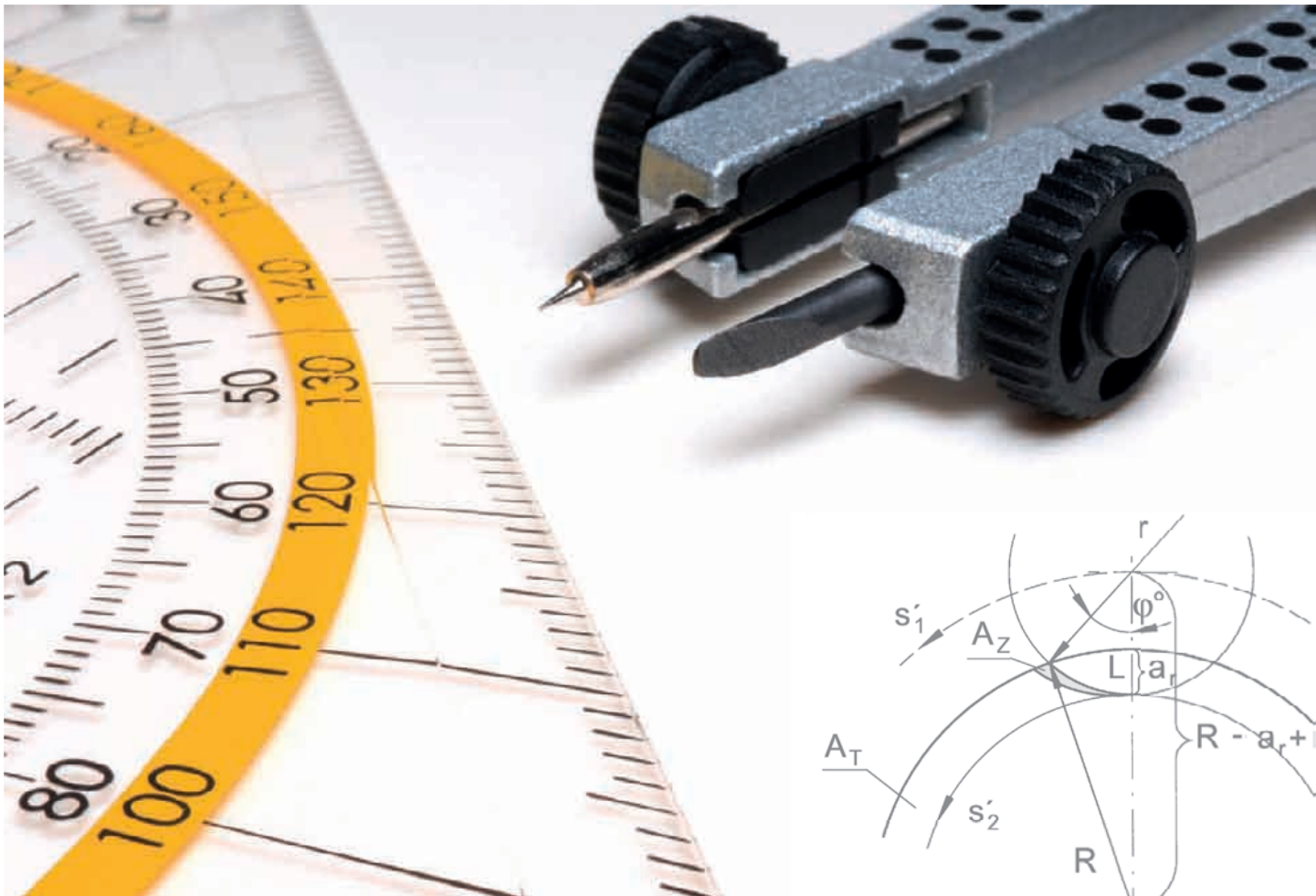

Inhalt/Summary

Seite/Page

Zubehör

W2-W7

Additional equipment

Anwendungsbeispiele

W8-U10

Examples for machining

W

Mit den mobilen Hochdruckstationen von **GRAF** können Sie die innengekühlten Werkzeuge optimal einsetzen.

Die Vorteile liegen auf der Hand:
Verlängerte Standzeiten der Schneidplatten
und Werkzeuge!

With the mobile high-pressure systems from **GRAF** you can employ the through cooled tools optimally.

The advantages are obvious: longer tool life!



W

Kühlmittelanschluss Standard

Standard connection for through cooling



für Rohr Ø 6 mm
for pipe Ø 6 mm

Kühlmittelanschluss
Connection for through cooling
004.00.19

M8 x 1



für Rohr Ø 6 mm
for pipe Ø 6 mm



Kühlmittelanschluss
Connection for through cooling
004.00.22

M8 x 1

Kühlmittelanschluss Schnellkupplung

Clip connection for through cooling

M10 x 1



Schnellkupplung
Clip connection
004.00.49

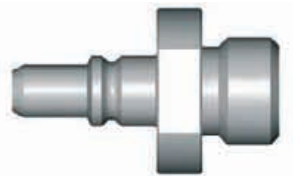

Stecker
Plug

M8 x 1 - 004.00.56
G1/8" - 004.00.57

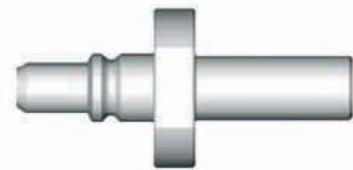

Stecker
Plug

Ø 6 mm - 004.00.59

für Rohr Ø 6 mm
for pipe Ø 6 mm



Anschluss
Coupling

M8 x 1 - 004.00.61
G1/8" - 004.00.16





D 041 VL
0,4-1 Nm

Drehmoment-Schraubendreher mit Skala
- mit variabler Einstellmöglichkeit
- numerische Drehmoment-Anzeige in Fensterskala
Drehmoment stufenlos einstellbar mit Einstellwerkzeug
Torque-Setter (im Lieferumfang enthalten).
Ergonomischer Mehrkomponentengriff, extrem handlich
durch leichte und kompakte Bauweise. Klicksignal beim
Erreichen des eingestellten Drehmomentwertes.
(Normen: EN ISO 6798, BS EN 26789, ASME B107.14.M.)
(Genauigkeit: $\pm 6\%$, rückführbar auf nationale Normale)

Torque screw driver with scale
- variable torque setting
- adjusted torque is shown on display
The Torque can be adjusted with a special torque setter (included).
Ergonomical form gives perfect handling abilities. Audible signal when
set torque is reached.
(Standard: EN ISO 6798, BS EN 26789, ASME B 107.14.M.)
(Precision: $\pm 6\%$)



D 15 VL
1-5 Nm



D 28 VL
2-8 Nm



ED 28 VL
für / for
D041VL / D15VL / D28VL

Einstellwerkzeug für Drehmoment-Schraubendreher
Griff: Celluloseacetat mit microfeiner Oberflächenstruktur
Klinge: Achtkantklinge, durchgehend gehärtet, verzinkt
Device for setting the required torque.
Handle: Celluloseacetat with micro structured surface
Blade: Octogonal (8 flats) blade, hardened galvanized



DT6PK
DT7PK
DT8PK
DT9PK
DT10PK
DT15PK
DT20PK
DT25PK

für / for
D041VL / D15VL / D28VL



Plus

Wechselklinge für TORX PLUS® Schrauben

Klinge: Hochwertiger Chrom-Vanadium-Molybdän Stahl, durchgehend gehärtet, mattverchromt
Wiha Chrom Top-Klingenspitze garantiert höchste Maßhaltigkeit.

Farbcodierung dunkelgrün

Anwendung: Zum kontrollierten Verschrauben bei vorgegebenem Drehmoment, in Kombination mit einem Wiha Drehmomentgriff.

Blade for TORX-Plus® screws

Blade: High quality Chrome-Vanadium steel, through hardened, chrome plated.

Wiha Chrome Blade guarantees maximum precision. Colored code dark green

Utilization: Controlled screw setting with definite torque in combination with Wiha torque screw driver handle.



DT6K
DT8K
DT15K

für / for
D041VL / D15VL / D28VL



Wechselklinge für Torx Schrauben

Klinge: Hochwertiger Chrom-Vanadium-Molybdän Stahl, durchgehend gehärtet, mattverchromt
Wiha Chrom Top-Klingenspitze garantiert höchste Maßhaltigkeit.

Farbcodierung dunkelgrün

Anwendung: Kontrolliertes Verschrauben bei vorgegebenem Drehmoment, in Kombination mit einem Wiha Drehmomentgriff.

Blade for Torx screws

Blade: High quality Chrome-Vanadium steel, through hardened, chrome plated.

Wiha Chrome Blade guarantees maximum precision. Colored code dark green

Utilization: Controlled screw setting with definite torque in combination with Wiha torque screw driver handle.



DSW15K
DSW20K
DSW25K
DSW30K
DSW40K
DSW50K
DSW60K

für / for
D041VL / D15VL / D28VL

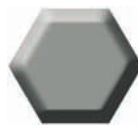

Wechselklinge für Innensechskant-Schrauben

Klinge: Hochwertiger Chrom-Vanadium-Molybdän-Stahl, durchgehend gehärtet, mattverchromt
Wiha Chrom Top-Klingenspitze garantiert höchste Maßhaltigkeit.

Farbcodierung rot

Anwendung: Kontrolliertes Verschrauben bei vorgegebenem Drehmoment, in Kombination mit einem Wiha Drehmomentgriff.

Blade for allen screws

Blade: High quality Chrome-Vanadium steel, through hardened, chrome plated.

Wiha Chrome Blade guarantees maximum precision. Colored code red

Utilization: Controlled screw setting with definite torque in combination with Wiha torque screw driver handle



D14ZBK

für / for
D041VL / D15VL / D28VL

Universal-Bithalter für C6,3 und E6,3 (1/4") Bits

Klinge: Hochwertiger Chrom-Vanadium-Molybdän Stahl, durchgehend gehärtet, mattverchromt.

Hülse: Aus rostfreiem Stahl

Anwendung: Zum kontrollierten Verschrauben bei vorgegebenem Drehmoment, in Kombination mit einem Drehmomentgriff.

Universal Bitholder for C6,3 and E6,3 (1/4") Bits

Blade: High quality Chrome-Vanadium steel, through hardened, chrome plated.

Collar: Stainless steel

Utilization: For controlled screw setting with definite torque in combination with torque screw driver handle.



D515QL

5-14 Nm

Drehmoment-Schraubendreher mit Skala

- mit variabler Einstellmöglichkeit

- numerische Drehmoment-Anzeige in Fensterskala

Drehmoment stufenlos einstellbar mit Einstellwerkzeug Torque-Setter (im Lieferumfang enthalten).

Ergonomischer Mehrkomponentengriff, extrem handlich durch leichte und kompakte Bauweise. Klicksignal beim Erreichen des eingestellten Drehmomentwertes.

(Normen: EN ISO 6798, BS EN 26789, ASME B107.14.M.)

(Genauigkeit: $\pm 6\%$, rückführbar auf nationale Normale)

Torque screw driver with scale

- variable torque setting

- adjusted torque is shown on display

The Torque can be adjusted with a special torque setter (included).

Ergonomical form gives perfect handling abilities. Audible signal when set torque is reached.

(Standard: EN ISO 6798, BS EN 26789, ASME B 107.14.M.)

(Precision: $\pm 6\%$)



ED515QL

für / for
D515QL

Einstellwerkzeug für Drehmoment-Schraubendreher

Griff: Celluloseacetat mit microfeiner Oberflächenstruktur

Klinge: Achteckklinge, durchgehend gehärtet, verzinkt

Device for setting the required torque.

Handle: Celluloseacetat with micro structured surface

Blade: Octogonal (8 flats) blade, hardened galvanized



DT15PQ
DT20PQ
DT25PQ
DT27PQ
DT30PQ

für / for
D515QL



Plus

Wechselklinge für TORX PLUS® Schrauben

Klinge: Hochwertiger Chrom-Vanadium-Molybdän Stahl, durchgehend gehärtet, mattverchromt
Wiha Chrom Top-Klingenspitze garantiert höchste Maßhaltigkeit.

Farbcodierung dunkelgrün

Anwendung: Zum kontrollierten Verschrauben bei vorgegebenem Drehmoment, in Kombination mit einem Wiha Drehmomentgriff.

Blade for TORX-Plus® screws

Blade: High quality Chrome-Vanadium steel, through hardened, chrome plated.

Wiha Chrome Blade guarantees maximum precision. Colored code dark green

Utilization: Controlled screw setting with definite torque in combination with Wiha torque screw driver handle.



D14ZBQ

für / for
D515QL

Universal-Bithalter für C6,3 und E6,3 (1/4") Bits

Klinge: Hochwertiger Chrom-Vanadium-Molybdän Stahl, durchgehend gehärtet, mattverchromt.

Hülse: Aus rostfreiem Stahl

Anwendung: Zum kontrollierten Verschrauben bei vorgegebenem Drehmoment, in Kombination mit einem Drehmomentgriff.

Universal Bitholder for C6,3 and E6,3 (1/4") Bits

Blade: High quality Chrome-Vanadium steel, through hardened, chrome plated.

Collar: Stainless steel

Utilization: For controlled screw setting with definite torque in combination with torque screw driver handle.



14ZQK

Bithalter mit Quergriff für C6,3 und E6,3(1/4") Bits

Klinge: Hochwertiger Chrom-Vanadium-Molybdän Stahl, durchgehend gehärtet, mattverchromt.

Hülse: Aus rostfreiem Stahl.

Anwendung: Zum kontrollierten Öffnen.

Universal Bitholder with T-handle for C6,3 and E6,3 (1/4") Bits

Blade: High quality Chrome-Vanadium steel, through hardened, chrome plated.

Collar: Stainless steel

Utilization: For controlled opening

“Benzinkolben” Nutenbearbeitung im Paket

Das Stechen der Nuten erfolgt mit PKD-bestückten Schneidplatten Typ 312 in einer Paketspannung mit Haltern Typ 340. Herstellbar sind Schneidplatten mit Breitentoleranzen von 0,005 mm.

Die Arbeitsfolge ist Vorstechen im Paket mit Nutaußenkantenfasung. Das Fertigstechen der Nutbreiten wird ebenfalls im Paket vorgenommen.

Material: GD-AISI12

Schnittdaten

Vorstechen:

$$v_c = 350 \text{ m/min}$$

$$v_f = 0,07 \text{ mm}$$

Fertigstechen:

$$v_c = 350 \text{ m/min}$$

$$v_f = 0,03 \text{ mm}$$



Multigrooving “Petrol Piston”

The grooves are machined with PCD-tipped inserts type 312 which are clamped in a multi-grooving toolholder of type 340. Closest tolerance of width is 0.005 mm.

Process:

- Pregrooving
- Finishing with a second set of inserts

Material: GD-AISI12

Cutting data

Pregrooving:

$$v_c = 350 \text{ m/min}$$

$$v_f = 0,07 \text{ mm}$$

Finishing:

$$v_c = 350 \text{ m/min}$$

$$v_f = 0,03 \text{ mm}$$

"Dieselkolben" Ringträger Nutenstechen

Das Stechen der Nut im Ni-resist Ringträger erfolgt mit **CBN-bestückten** Schneidplatten Typ 229.

Die Arbeitsfolge ist Vorstechen mit anschließendem Kopieren der Nutflanken.

Die Schneidkanten sind im Mikrobereich entsprechend präpariert, da zu hoher Schnittdruck Loslösungen des Ringträgers im Aluguss zur Folge hätte.

Material: Ni-resist (austenitisches Gusseisen - ähnl. DIN1694)

Schnittdaten:

$v_c = 220$ m/min

$v_f = 0,06$ mm



Machining of Ni-resist ring on "Diesel Piston"

PCBN-tipped insert of type 229 is used to do the grooving application in the Ni-resist ring.

The process is pregrooving followed by profiling the flanks of the groove.

To avoid a high cutting pressure which forces the possibility to damage the seating of the ring, the cutting edge of the insert has a special preparation.

Material: Ni-resist (austenitic cast iron similar to DIN1694)

Cutting data:

$v_c = 220$ m/min

$v_f = 0,06$ mm

Nockenwelle "Lagersitze" drehen

Die Lager zwischen den Nocken erfordern normalerweise für die Drehbearbeitung rechte und linke Werkzeuge. Diese Werkzeugwechsel bedeuten hohe Nebenzeiten. Stechwerkzeuge des Systems 229 erlauben das Stechen der Nocken und das Drehen der Lagersitze in nur einem Schnitt bei Aufmaßen bis 2,5 mm. Die Bearbeitung erfolgt trocken.

Die erreichte Zylindrizität und Konizität der Lagerstellen liegen bei $\leq 0,02$ mm.

Material: 16MnCr5 - geschmiedet

Schnittdaten

Nocken:

$$v_c = 160 \text{ m/min}$$

$$v_f = 0,25 \text{ mm}$$

Lager:

$$v_c = 160 \text{ m/min}$$

$$v_f = 0,25 \text{ mm}$$

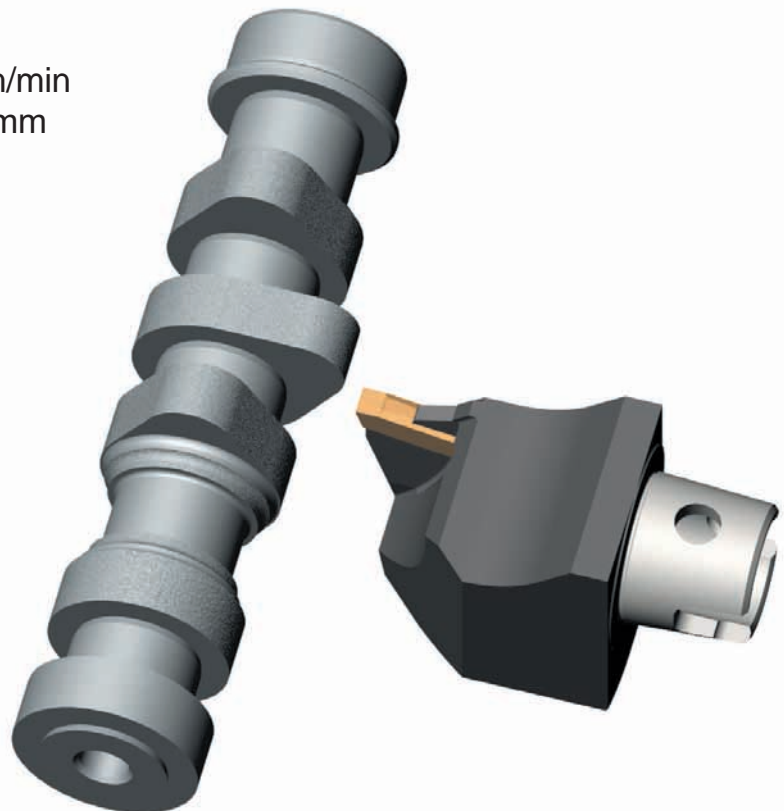

Machining on camshafts

Because of its design, turning the camshafts seats usually require left and right hand tools. Due to the toolchanges this results in high nonproductive time periods.

With the inserts of type 229, the cams and seats can be machined without a toolchange.

Stock removal is up to 2,5 mm (.098"). No coolant.

The amount of taper and cylindricity at the bearing seat we achieved is $\leq 0,02$ mm.

Material: 16MnCr5 - forged

Cutting data

Cam:

$$v_c = 160 \text{ m/min}$$

$$v_f = 0,25 \text{ mm}$$

Seat:

$$v_c = 160 \text{ m/min}$$

$$v_f = 0,25 \text{ mm}$$

Schneidstoffgruppen nach DIN ISO 513

Cutting Material Groups per DIN ISO 513

Gruppen Main group	Symbol	Untergruppen Subgroups
Hartmetall Carbide	HW	unbeschichtetes Hartmetall auf WC-Basis uncoated carbides based upon WC
	HT	unbeschichtetes Hartmetall auf TiC/TiN-Basis (Cermets) uncoated carbides based upon TiC/TiN (Cermets)
	HF	Feinkornhartmetall micro grane carbides
	HC	beschichtetes Hartmetall / Cermets coated carbides / cermets
Schneidkeramik Ceramic cutting material	CA	Oxidkeramik auf Al_2O_3 -Basis Oxide ceramics based upon Al_2O_3
	CM	Mischkeramik auf Al_2O_3 + Metallcarbide Mixed ceramics based upon Al_2O_3 + metal carbide
	CN	Nitridkeramik auf Si_3N_4 -Basis Nitride ceramics based upon Si_3N_4
	CC	beschichtete Schneidkeramik Coated ceramics
Diamant Diamond	DM	Monokristalliner Diamant (MKD) Monocrystalline diamond (MCD)
	DP	Polykristalliner Diamant (PKD) Polycrystalline diamond (PCD)
Bornitrid Boron nitride	BN	Polykristallines, kubisches Bornitrid (CBN) Polycrystalline, cubic boron nitride (PCBN)

Technische Änderungen aufgrund von Weiterentwicklungen behalten wir uns vor.

Keine Gewähr für Druckfehler und Irrtümer.

Nachdruck, auch auszugsweise, nur mit unserer schriftlichen Genehmigung.

Stand: März 2018

Subject to technical changes developments.

No responsibility for errors or printer's errors accepted.

This catalogue may not be reprinted or photocopied in whole or in part without our written permission.

Edition: March 2018



Deutschland / Germany

Hartmetall Werkzeugfabrik

Paul HORN GmbH

Unter dem Holz 33-35, D-72072 Tübingen

Tel +49 (0)7071/70040, Fax +49 (0)7071/72893

E-Mail: info@phorn.de, www.phorn.de

Großbritannien / UK and Ireland

HORN CUTTING TOOLS Ltd.

32 New Street, Ringwood, Hampshire,

BH24 3AD, Tel +44 (0)1425/481 800

Fax +44 (0)1425/481 888

E-Mail: info@phorn.co.uk, www.phorn.co.uk

Frankreich / France

HORN S.A.S

665, av. Blaise Pascal, Zone Industrielle,

77127 Lieusaint

Tel +33 (0)1648859-58, Fax +33 (0)1648860-49

E-Mail: infos@horn.fr, www.horn.fr

USA

HORN USA, Inc.

320 Premier Court, Suite 205, Franklin,

TN 37067

Tel +1 (888)818-HORN, Fax +1(615)771-4101

E-Mail: sales@hornusa.com, www.hornusa.com

Ungarn / Hungary

HORN Magyarország Kft.

H-9027 Győr, Gesztenyefa u. 4

Tel +36 96 55 05 31, Fax +36 96 55 05 32

E-Mail technik@phorn.hu, www.phorn.hu

China

HORN (Shanghai) Trading Co. Ltd.

Room 905, No. 518 Anyuan Road, P.R. of China

Putuo District, Shanghai 200060

上海市安远路518号905室 邮编: 200060

Tel.: +86 21 52833505; 52833205

Fax: +86 21 52832562

E-Mail: info@phorn.cn, www.phorn.cn

Mexico

HORN HERRAMIENTAS MÉXICO

Av. Hércules # 500 Bodega #8

Polígono Empresarial Sta. Rosa

Santa Rosa Jáuregui, Querétaro

C.P. 76220

Tel.: +442 291-0321, Fax: +442 291-0915

E-Mail: ventas@phorn.mx, www.phorn.mx

Russland / Russia

HORN RUS LLC

121059, Moscow

5 Bryanskaya street

Tel.: +7 (495) 968 21 68, Fax +7 (495) 960 21 68

E-Mail: info@hornrus.com, www.hornrus.com



BLUECOMPETENCE
Alliance Member

Partner of the Engineering Industry
Sustainability Initiative

TECHNOLOGIEVORSPRUNG IST HORN
HORN - EXCELLENCE IN TECHNOLOGY

